

PRODUCT INFORMATION PACKET



Model No: CZ6T17TK3D

Catalog No: 117906.00

..1/2HP..1725RPM.56HC.TENV.230/460V.3PH.60HZ.CONT.40C.1.15SF.RIGID-C-FACE.CZ6T17TK3.....STAINLESS ENCAPSULATED W/SGRs.NONE.....

Encapsulated



Regal and Leeson are trademarks of Regal Beloit Corporation or one of its affiliated companies.

©2018 Regal Beloit Corporation, All Rights Reserved. MC017097E





Nameplate Specifications

Output HP	0.50 Hp	Output KW	0.37 kW
Frequency	60 Hz	Voltage	208-230/460 V
Current	1.7-1.6/0.80 A	Speed	1725 rpm
Service Factor	1.15	Phase	3
Efficiency	78.5 %	Duty	Continuous
Insulation Class	F	Design Code	B
KVA Code	K	Frame	56C
Enclosure	Totally Enclosed Non Ventilated	Overload Protector	No
Ambient Temperature	40 °C	Drive End Bearing Size	6205
Opp Drive End Bearing Size	6205	UL	Recognized
CSA	Y	CE	Y
IP Code	69		

Technical Specifications

Electrical Type	Squirrel Cage Induction Run	Starting Method	Across The Line
Poles	4	Rotation	Reversible
Mounting	Rigid base	Motor Orientation	HORIZONTAL
Drive End Bearing	BALL	Opp Drive End Bearing	BALL
Frame Material	Rolled Steel	Shaft Type	NEMA 56
Overall Length	10.97 in	Frame Length	5.75 in
Shaft Diameter	0.625 in	Shaft Extension	1.88 in
Assembly/Box Mounting	F1 ONLY		
Outline Drawing	028767-575	Connection Diagram	005010.52

RBC PROPRIETARY AND CONFIDENTIAL INFORMATION
 This document is the property of REGAL BELOIT CORPORATION ("RBC") including its subsidiaries and divisions and contains proprietary information of RBC. This document is loaned on the express condition that neither it nor the information contained therein shall be disclosed to others without the express written consent of RBC, and that the information shall be used by the recipient only as approved expressly by RBC. This document shall be returned to RBC upon its request. This document may be subject to certain restrictions under U.S. export control laws and regulations.

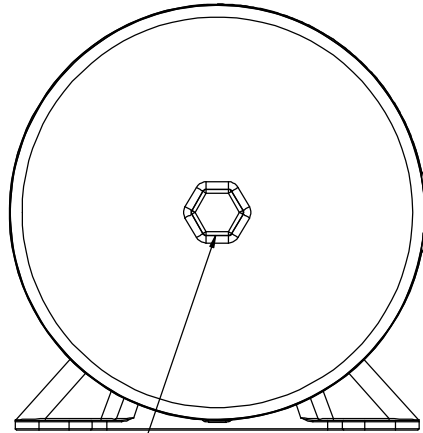

3/4" HEX DRIVER FOR COVER REMOVAL

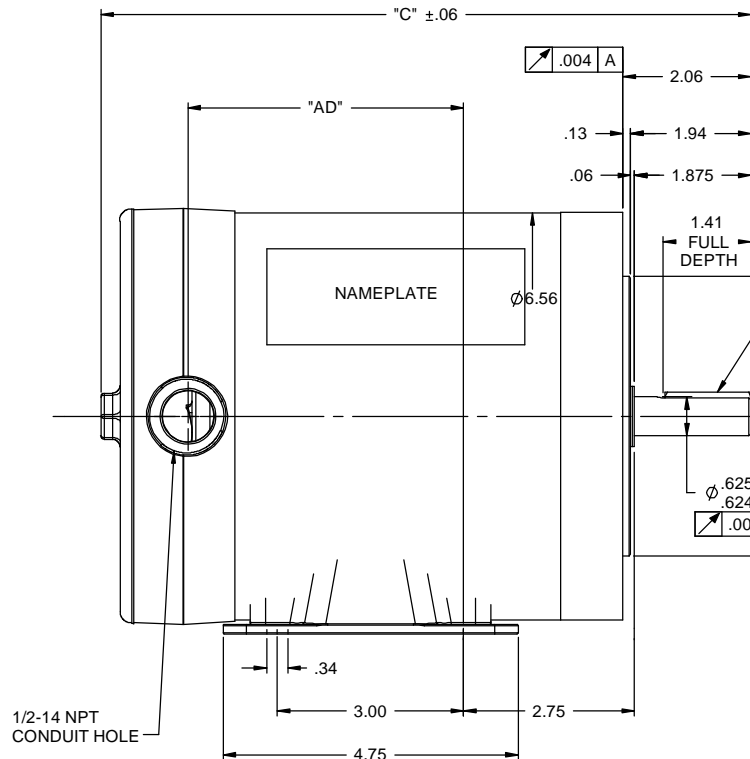

1/2-14 NPT CONDUIT HOLE

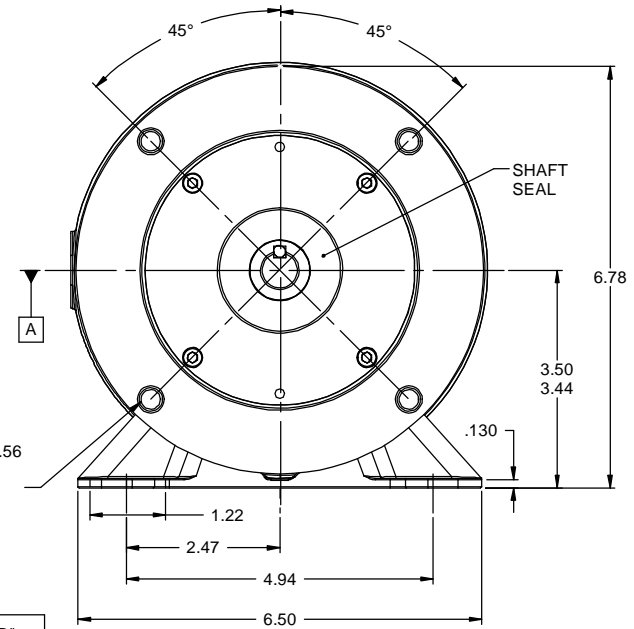

SHAFT SEAL

DASH NO	"C"	"AD"
525	10.47	4.44
550	10.72	4.69
575	10.97	4.94
600	11.22	5.19
625	11.47	5.44
650	11.72	5.69
675	11.97	5.94
700	12.22	6.19
725	12.47	6.44
750	12.72	6.69
775	12.97	6.94

(4) 3/8-16 UNC-2B X .56 DEEP ON A Ø5.875 B.C.

TOLERANCES UNLESS SPECIFIED		REGAL BELOIT CORPORATION		DRAWN	LST 9/9/09
DEC	INCHES			CHK	
X	±.1			APPR	
XX	±.03	TITLE		SCALE	1:2
XXX	±.005	OUTLINE 56C FRAME		REF	
XXXX	±.0005	TENV RIGID "C"		FINISH	
NO	REVISION	BY & DATE	MATL	PAGE	OF
			FINISH		
			PREV	SIZE	DRAWING NO
			NETWORK FILE NAME	B	028767
					REV



VIEW FROM OUTSIDE OF MOTOR AT SWITCH END.

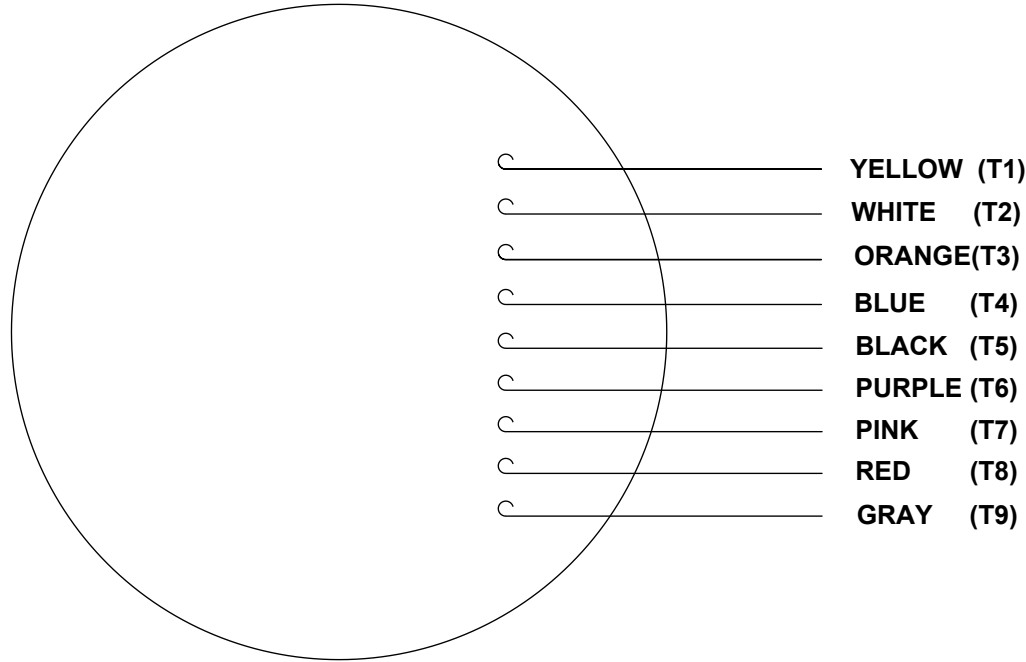

LINE LEADS

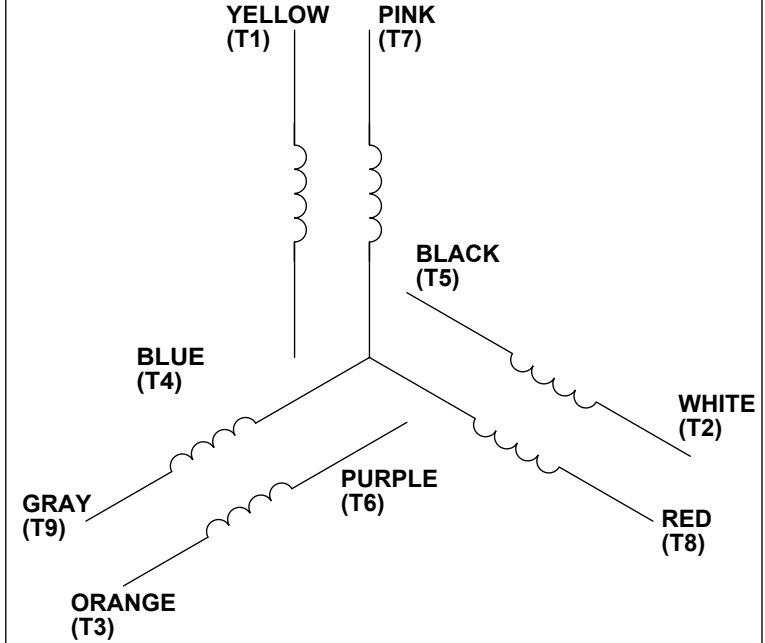

VOLTAGE	L1	L2	L3	JOIN & INSULATE
HIGH	T1	T2	T3	(T4, T7) (T5, T8) (T6, T9)
LOW	T1, T7	T2, T8	T3, T9	T4, T5, T6

RBC PROPRIETARY AND CONFIDENTIAL INFORMATION
This document is the property of REGAL BELOIT CORPORATION ("RBC") including its subsidiaries and divisions and contains proprietary information of RBC. This document is loaned on the express condition that neither it nor the information contained therein shall be disclosed to others without the express written consent of RBC, and that the information shall be used by the recipient only as approved expressly by RBC. This document shall be returned to RBC upon its request. This document may be subject to certain restrictions under U.S. export control laws and regulations.

DRAWING REVISION C	REVISION BY PVR	DATE 04/23/14
ECO ECO-0049985	APPROVED BY JD	DATE 04/23/14
ECO DESCRIPTION UPDATED PER ECO-0049985		
<small>COPYRIGHT REGAL BELOIT AMERICA, INC. ALL RIGHTS RESERVED. PROPRIETARY AND CONFIDENTIAL INFORMATION - THIS DOCUMENT IS THE PROPERTY OF REGAL BELOIT AMERICA, INC. ("OWNER") AND CONTAINS OWNER'S PROPRIETARY INFORMATION. ANY PERSON, CORPORATION OR OTHER FIRM RECEIVING IT IS DEEMED, BY RECEIVING IT, TO AGREE THAT IT, AND/OR ANY PART OF IT, SHALL NOT BE DISCLOSED TO ANY PERSON, CORPORATION OR OTHER ENTITY, DUPLICATED, AND/OR USED, EXCEPT AS EXPRESSLY APPROVED IN WRITING IN ADVANCE BY OWNER. THIS DOCUMENT SHALL BE RETURNED TO OWNER UPON REQUEST. IT MAY BE SUBJECT TO CERTAIN RESTRICTIONS UNDER APPLICABLE EXPORT CONTROL LAWS AND REGULATIONS.</small>		

TOLERANCES UNLESS OTHERWISE SPECIFIED:			
DEC.	INCH	mm	ANGLE
.X	+0.1	[±2.5]	±0.5°
.XX	±0.01	[±0.25]	
.XXX	±0.005	[±0.127]	
.XXXX	±0.0005	[±0.0127]	
REMOVE BURRS & BREAK SHARP			
EDGES: .003/.015 [.076/.381]			
CORNER FILLETS: .02 [.51]			
MACHINED SURFACES: 125/3.2			
INCH <input checked="" type="checkbox"/> mm <input checked="" type="checkbox"/>			
mm SHOWN IN [BRACKETS]			

DRAWN BY LST
DATE 4/3/14
APPROVED BY
DATE
PROCESS/FINISH
THIRD ANGLE PROJECTION

Regal Beloit America, Inc.

DESCRIPTION LEAD ASSY EXT. WIRING DIA. 3 PH. W/O PROT.	
MATERIAL	
SIZE A	DRAWING NUMBER 00501052
SHEET 1 OF 1	

