

PRODUCT INFORMATION PACKET



Model No: C143T34FC20AA

Catalog No: 122086.00

..1.5HP..3600RPM.143JMV.TEFC.230/460V.3PH.60HZ.CONT.40C..C-FACE.....JM PUMP MOTOR.....
JM



Regal and Leeson are trademarks of Regal Beloit Corporation or one of its affiliated companies.

©2018 Regal Beloit Corporation, All Rights Reserved. MC017097E





Nameplate Specifications

Output HP	1.50 Hp	Output KW	1.1 kW
Frequency	60 Hz	Voltage	230/460 V
Current	4.0/2.0 A	Speed	3515 rpm
Service Factor	1.15	Phase	3
Efficiency	84 %	Duty	Continuous
Insulation Class	F	Design Code	B
KVA Code	M	Frame	143JM
Enclosure	Totally Enclosed Fan Cooled	Overload Protector	No
Ambient Temperature	40 °C	Drive End Bearing Size	6206
Opp Drive End Bearing Size	6203	UL	Recognized
CSA	Y	CE	Y
IP Code	43		

Technical Specifications

Electrical Type	Squirrel Cage Inverter Rated	Starting Method	Line Or Inverter
Poles	2	Rotation	Reversible
Mounting	Round	Motor Orientation	HORIZONTAL
Drive End Bearing	BALL	Opp Drive End Bearing	BALL
Frame Material	Rolled Steel	Shaft Type	JM
Overall Length	15.49 in	Frame Length	8.06 in
Shaft Diameter	0.875 in	Shaft Extension	4.28 in
Assembly/Box Mounting	F1 ONLY		
Outline Drawing	B-100878LE-806	Connection Diagram	A-EE7308-LE

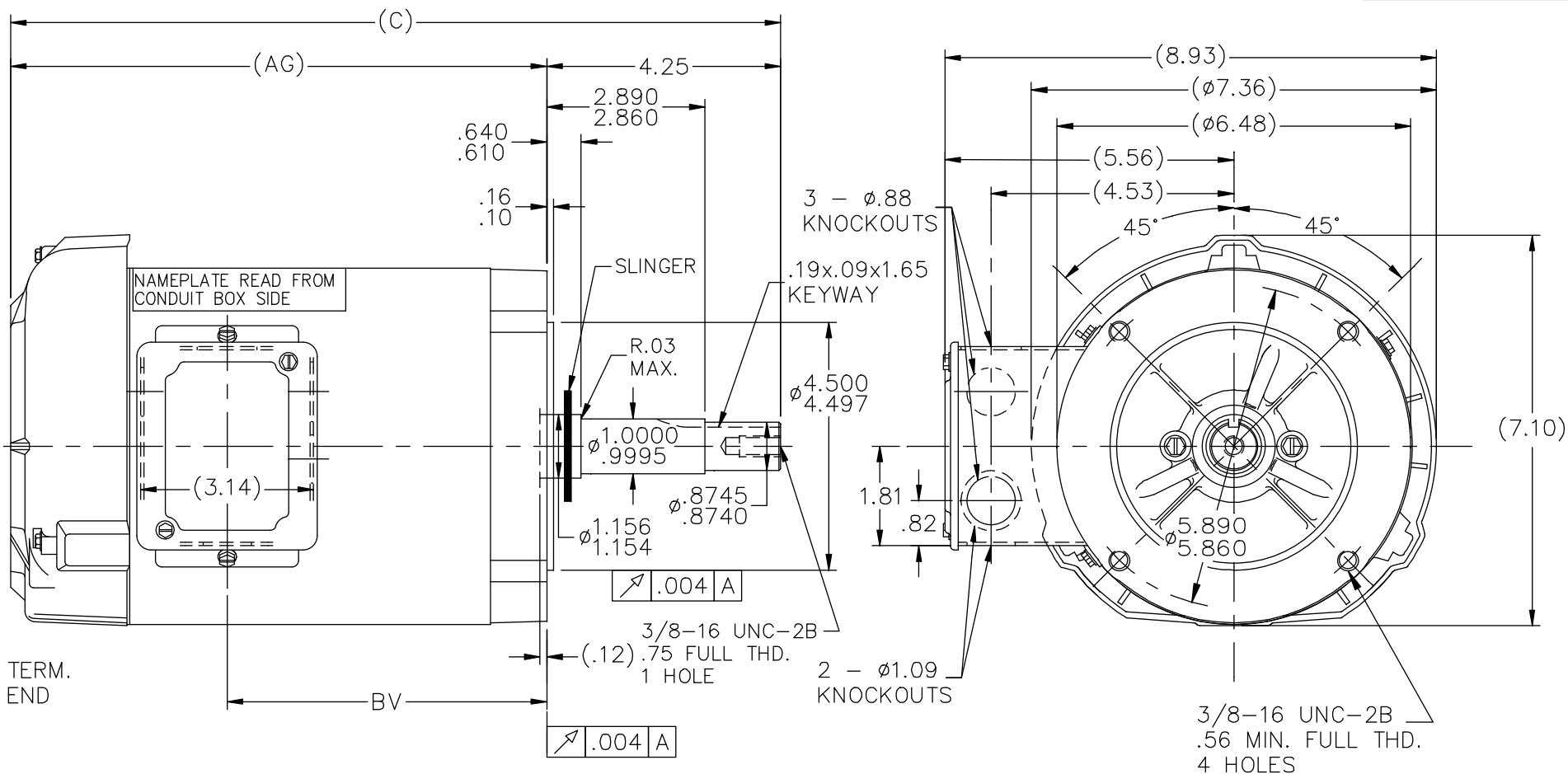

DASH	FR	C	AG	BV	DASH	FR	C	AG	BV
					806	145	15.49	11.24	7.31
656	145	13.99	11.74	5.81	856	145	15.99	11.74	7.81
706	145	14.49	10.24	6.31	906	145	16.49	12.24	8.31
756	145	14.99	11.74	6.81	956	145	16.99	12.74	8.81

NOTE:
'C' BOX CAN BE ROTATED 180°

				TOLERANCES UNLESS SPECIFIED			ELECTRIC MOTORS GEARMOTORS AND DRIVES	DRAWN	UD 01/08/14					
				DEC.	INCHES			CHK	PI 01/08/14					
				.X	±.1	TITLE OUTLINE JM EXT. 140 FR. - BB - TEFC - 'C' FACE - 1 ϕ	APPD	SCALE	11=32					
				.XX	±.03			REF	100878					
				.XXX	±.005			MAT'L.	FMF					
				.XXXX	±.0005			FINISH	PREV					
NO.	REVISION	BY & DATE	CHK	ANG	±7'30"									
THIS DRAWING IN DESIGN AND DETAIL IS OUR PROPERTY AND MUST NOT BE USED EXCEPT IN CONNECTION WITH OUR WORK ALL RIGHTS OF DESIGN AND INVENTION ARE RESERVED THIS IS AN ELECTRONICALLY GENERATED DOCUMENT - DO NOT SCALE THIS PRINT				RFP		CAD FILE	100878LE	SIZE	A	DRAWING NO.	100878LE	PAGE	OF	REV.

THREE PHASE DUAL VOLTAGE MOTOR

HIGH VOLTAGE

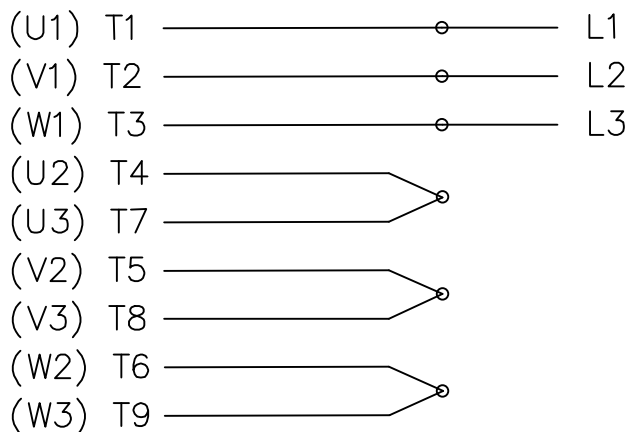

LOW VOLTAGE

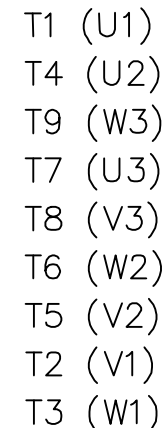
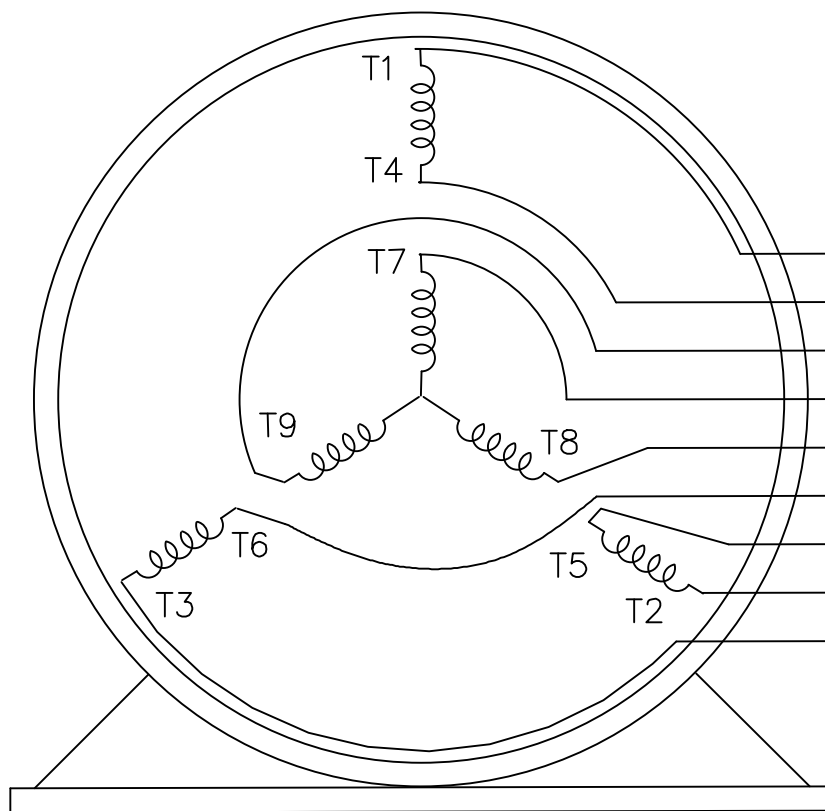
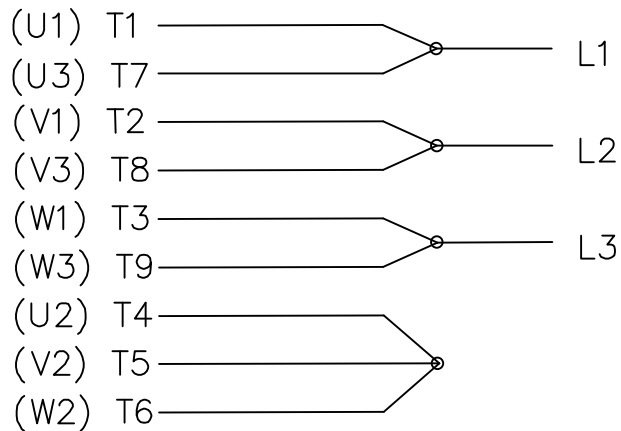

VIEW OF TERMINAL END

REF.
WINDING DIAGRAM

T8Y, T2Y, T2BL, T4BX, T2EC, T2G
T6BZ, T2B, T6BL, T4AV, T6B, T4B

				TOLERANCES UNLESS SPECIFIED		 ELECTRIC MOTORS GEARMOTORS AND DRIVES	DRAWN HLB 04-29-2002			
				DEC.	INCHES		CHK	ML 05-03-2002		
				.X	±.1		APPD GK 05-03-2002			
				.XX	±.01	TITLE CONNECTION DIAGRAM				
				.XXX	±.005	3Ø - DUAL VOLTAGE MOTOR				
2	ADDED IEC NOTATIONS... (U1), (V1) ETC. (MU105786)	REP 01-11-2012	DR	.XXX	±.005		SCALE 1=1			
1	NEW DRAWING	HLB 05-03-2002	ML	.XXXX	±.0005	MAT'L.	REF			
NO.	REVISION	BY & DATE	CHK	ANG	±1/2'	FINISH	PREV			
THIS DRAWING IN DESIGN AND DETAIL IS OUR PROPERTY AND MUST NOT BE USED EXCEPT IN CONNECTION WITH OUR WORK ALL RIGHTS OF DESIGN AND INVENTION ARE RESERVED THIS IS AN ELECTRONICALLY GENERATED DOCUMENT - DO NOT SCALE THIS PRINT				RFP		CAD FILE EE7308-LE	SIZE A	DRAWING NO. EE7308-LE	PAGE OF 2	REV. 2
				DIST	LB-WP					



Motor Load Data								
Load	0%	25%	50%	75%	100%	115%	125%	LR
Current (Amps)	0.90	1.00	1.30	1.60	2.00	2.20	2.40	19.4
Torque (ft-lb)	0.00	0.60	1.10	1.70	2.20	2.60	2.80	7.3
RPM	3600	3575	3555	3535	3515	3500	3485	0
Efficiency (%)		73.4	82.3	84.8	84.0	84.0	84.0	
P.F. (%)	17.0	47.5	67.2	77.8	83.5	85.1	86.8	58.0

Motor Speed Data						Information Block																					
LR	Pull-Up	BD	Rated	Idle		HP	Sync. RPM	Frame	Enclosure	Construction	Voltage	Frequency	Design	LR Code letter	Service Factor	Temp Rise @ FL	Duty	Ambient	Elevation	Rotor/Shaft wk ²	Ref Wdg	Sound Pressure @ 1M	VFD Rating	Outline Dwg	Conn. Diag	Additional Specifications:	
LR	650	2815	3515	3600		1.5	3600	143	TEFC	TFR	230/460#190/380	60	A	M	1.15	38	CONT	40 °C	1,000 feet	0.05	Z12141 R1	69	CONSTANT 2:1	B-100878LE-806	A-EE7308-1E		
Speed (RPM)	0	650	2815	3515	3600																						
Current (Amps)	19.4	18.6	12.1	2.00	0.90																						
Torque (ft-lb)	7.3	6.1	9.6	2.20	0.00																						

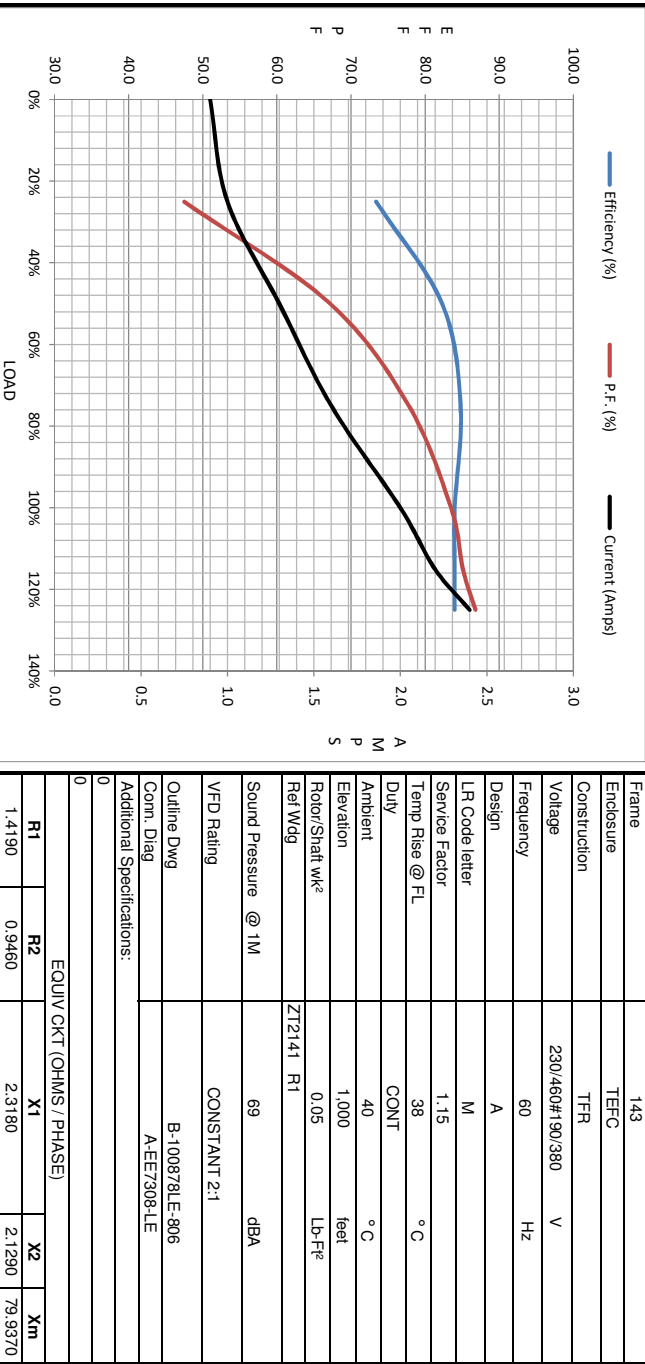

EQUIV CKT (OHMS / PHASE)				
R1	R2	X1	X2	Xm
1.4190	0.9460	2.3180	2.1290	79.9370

