

PRODUCT INFORMATION PACKET



Model No: D365T11FB13A

Catalog No: B199032.00

..50HP..1200RPM.365T.TEFC.230/460V.3PH.60HZ.CONT.40C.1.15SF.RIGID.....GENERAL PURPOSE.....

Totally Enclosed Fan Cooled (TEFC)



Regal and Leeson are trademarks of Regal Beloit Corporation or one of its affiliated companies.

©2018 Regal Beloit Corporation, All Rights Reserved. MC017097E





Nameplate Specifications

Output HP	50 Hp	Output KW	37.0 kW
Frequency	60 Hz	Voltage	230/460 V
Current	121.0/60.5 A	Speed	1188 rpm
Service Factor	1.15	Phase	3
Efficiency	94.1 %	Duty	Continuous
Insulation Class	F	Design Code	B
KVA Code	G	Frame	365T
Enclosure	Totally Enclosed Fan Cooled	Overload Protector	No
Ambient Temperature	40 °C	Drive End Bearing Size	6313
Opp Drive End Bearing Size	6213	UL	Listed
CSA	Y	CE	Y
IP Code	55		

Technical Specifications

Electrical Type	Squirrel Cage Inverter Rated	Starting Method	Wye Start Delta Run Or Inverter
Poles	6	Rotation	Reversible
Mounting	Rigid base	Motor Orientation	HORIZONTAL
Drive End Bearing	BALL	Opp Drive End Bearing	BALL
Frame Material	Cast Iron	Shaft Type	T
Overall Length	34.30 in	Frame Length	16.73 in
Shaft Diameter	2.375 in	Shaft Extension	5.88 in
Assembly/Box Mounting	F1/F2 CAPABLE		
Outline Drawing	SS556999-365T	Connection Diagram	EE7308AA

OUTLINE

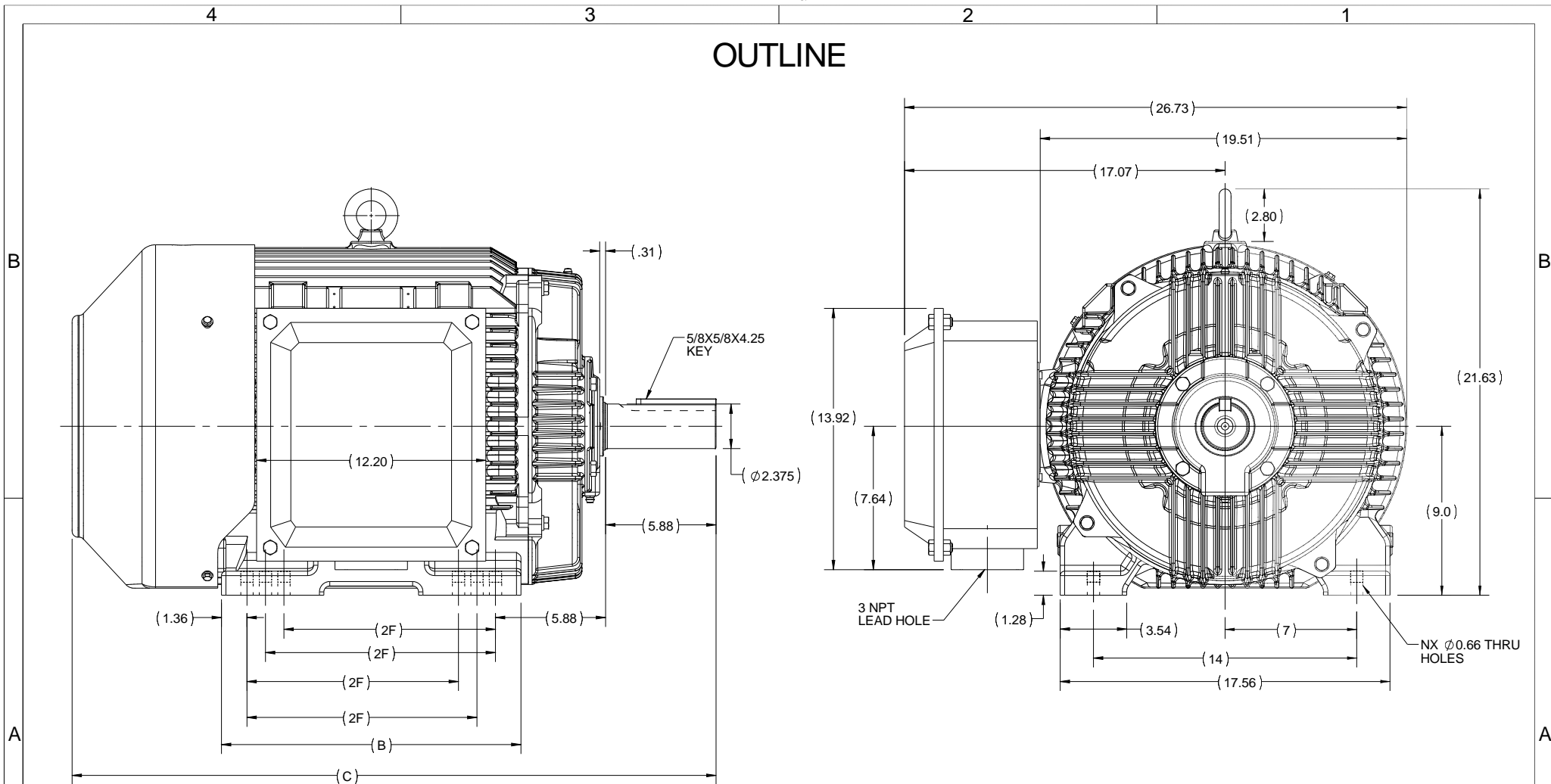

365T	15.94	34.30	12.25	12
364T	14.96	33.32	11.25	8
FRAME	B	C	2F	N

DRAWING REVISION A	REVISION BY UDAY	DATE 4/7/2016
ECO ECO-0105009	APPROVED BY SBD	DATE 4/7/2016
ECO DESCRIPTION NEW OUTLINE RELEASE		
<small>COPYRIGHT REGAL BELOIT AMERICA, INC. ALL RIGHTS RESERVED. PROPRIETARY AND CONFIDENTIAL INFORMATION - THIS DOCUMENT IS THE PROPERTY OF REGAL BELOIT AMERICA, INC. ("OWNER") AND CONTAINS OWNER'S PROPRIETARY INFORMATION. ANY PERSON, CORPORATION OR OTHER FIRM RECEIVING IT IS DEEMED, BY RECEIVING IT, TO AGREE THAT IT, AND/OR ANY PART OF IT, SHALL NOT BE DISCLOSED TO ANY PERSON, CORPORATION OR OTHER ENTITY, DUPLICATED, AND/OR USED, EXCEPT AS EXPRESSLY APPROVED IN WRITING IN ADVANCE BY OWNER. THIS DOCUMENT SHALL BE RETURNED TO OWNER UPON REQUEST. IT MAY BE SUBJECT TO CERTAIN RESTRICTIONS UNDER APPLICABLE EXPORT CONTROL LAWS AND REGULATIONS.</small>		

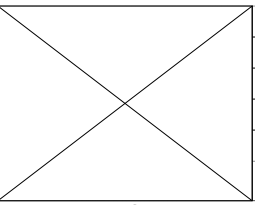

DRAWN BY NIV	 Regal Beloit America, Inc.		
DATE 25/03/2016			
APPROVED BY SBD	DESCRIPTION OUTLINE 360T FR-TEFC		
DATE 25/03/2016	MATERIAL		
REFERENCE	PROCESS/FINISH		
THIRD ANGLE PROJECTION	SIZE B	DRAWING NUMBER SS556999	SHEET 1 OF 1



LOW VOLTAGE



HIGH VOLTAGE



DRAWING REVISION K	REVISION BY AJW	DATE 07-17-2015
ECO ECO-0081632	APPROVED BY T. VUE	DATE 07-17-2015
ECO DESCRIPTION REV'D IEC MARKINGS PER IEC 60034-8		
COPYRIGHT REGAL BELOIT AMERICA, INC. ALL RIGHTS RESERVED. PROPRIETARY AND CONFIDENTIAL INFORMATION - THIS DOCUMENT IS THE PROPERTY OF REGAL BELOIT AMERICA, INC. ("OWNER") AND CONTAINS OWNER'S PROPRIETARY INFORMATION. ANY PERSON, CORPORATION OR OTHER FIRM RECEIVING IT IS DEEMED, BY RECEIVING IT, TO AGREE THAT IT, AND/OR ANY PART OF IT, SHALL NOT BE DISCLOSED TO ANY PERSON, CORPORATION OR OTHER ENTITY, DUPLICATED, AND/OR USED, EXCEPT AS EXPRESSLY APPROVED IN WRITING IN ADVANCE BY OWNER. THIS DOCUMENT SHALL BE RETURNED TO OWNER UPON REQUEST. IT MAY BE SUBJECT TO CERTAIN RESTRICTIONS UNDER APPLICABLE EXPORT CONTROL LAWS AND REGULATIONS.		

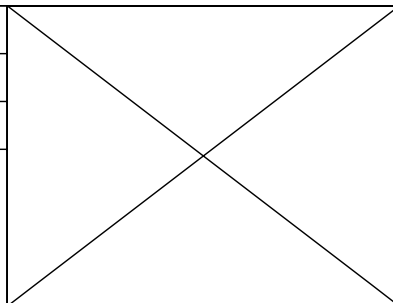

DRAWN BY LZ	Regal Beloit America, Inc.	
DATE 01-12-1994		
APPROVED BY GK	DESCRIPTION CONN DIAGRAM-EXTERNAL 3Ø-2/1 DELTA-12 LEADS	
DATE 01-14-1994		
REFERENCE	MATERIAL	PROCESS/FINISH
THIRD ANGLE PROJECTION	SIZE A	DRAWING NUMBER EE7308AA
		SHEET 1 OF 1



P.O. BOX 8003
WAUSAU, WI 54401-8003
PH. 715-675-3311

DATA VOLTS: 460

CERTIFICATION DATA SHEET

CONN. DIAGRAM: EET7308AA
OUTLINE: SSS56999
WINDING: HE32256004

CAT #: B199032.00

NONE 2

TYPICAL MOTOR PERFORMANCE DATA

HP	KW	SYNC RPM	FL RPM	FRAME	ENCLOSURE	TYPE	KVA CODE	DESIGN	
50	37	1200	1188	365T	TEFC	TFC	G	B	
PH	HZ	VOLTS	AMPS	START TYPE	DUTY	INSL	S.F.	AMB	ELEV.
3	60/50	230/460#190/380	121/60.5&119/59.5	START D RUN OR INV	CONT	F	1.15	40	3300
F.L. EFF	94.1	3/4 LD EFF	94.1	1/2 LD EFF	93.6	GTD EFF	93.6	ELECT. TYPE	SO CAGE INVERTED
F.L. PF	82.5	3/4 LD PF	78.0	1/2 LD PF	68.5	93.6			
F.L. TORQUE	LR AMPS @ 460 V	L.R. TORQUE	398 LB-FT	180%	620 LB-FT	B.D. TORQUE	281%	F.L. RISE (°C)	65
221 LB-FT									
PRESSURE @ 3	POWER	ROTOR WK²	27.5 LB-FT²	MAX. LOAD WK²	900 LB-FT²	SAFE STALL TIME	20 SEC.	STARTS/HOUR	2
68 DBA	77 DBA							MOTOR WGT	1075 LB.

*** SUPPLEMENTAL INFORMATION ***

DE BRACKET TYPE	ODE BRACKET TYPE	MOUNT TYPE	MOTOR ORIENTATION	SEVERE DUTY	HAZARDOUS LOCATION	DRIP COVER	SCREENS	PAINT
STANDARD	STANDARD	RIGID	HORIZONTAL	NO	DIVISION 2 T2B	NO	NONE	BLUE (ENAMEL)
BEARINGS	GREASE	SHAFT TYPE	SPECIAL DE	SPECIAL ODE	SHAFT	MATERIAL	FRAME MATERIAL	
BALL BALL 6313	POLYREX EM	T	NONE	NONE	1045 HOT ROLLED (C-204)		CAST IRON	

THERMOSTATS	PROTECTORS	WDG RTD's	BRG RTD's	THERMISTORS	CONTROL	SPACE HEATERS
NONE	NOT	NONE	NONE	NONE	FALSE	NA
R1 (ohms/ph)	R2 (ohms/ph)	X1 (ohms/ph)	X2 (ohms/ph)	Xm (ohms/ph)	VIBRATION (in/sec)	FLOAT
0.083	0.05	0.34	0.629	10.546	0.080	ODE

* N O T E S *		INVERTER TORQUE: VARIABLE 10:1	
		INV. HP SPEED RANGE: NONE	
		ENCODER: NONE	
		BRAKE: NONE	
		FT-LB: NA	
		VOLTAGE: NONE	
		HZ: NONE	

DATE: 1/19/2018	UL: D-LE,WUXI TEFC BLUEWHALE CLASS 1 DIV. 2 UL LISTED
-----------------	---



Motor Load Data						
Load	0%	25%	50%	75%	100%	LR
Current (Amps)	25.0	28.5	36.8	47.8	60.5	362
Torque (ft-lb)	0.00	55.0	110	165	221	398
RPM	1200	1198	1195	1190	1188	0
Efficiency (%)		90.2	93.6	94.1	94.1	93.6
P.F. (%)	5.0	46.0	88.5	78.0	82.5	83.5
						84.0

Motor Speed Data						Information Block																					
LR	Pull-Up	BD	Rated	Idle		HP	Sync. RPM	Frame	Enclosure	Construction	Voltage	Frequency	Design	LR Code letter	Service Factor	Temp Rise @ FL	Duty	Ambient	Elevation	Rotor/Shaft wk ²	Ref Wdg	Sound Pressure @ 1M	VFD Rating	Outline Dwg	Conn. Diag	Additional Specifications:	
						50.0	1200	365	TEFC	TFC	230/460#190/380	60	B	G	1.15	65	CONT	40	1,000	27.5	HE32256004 NONE	68	VARIABLE 10:1	SS556999	EET308AA		
Speed (RPM)	0	600	1135	1188	1200																						
Current (Amps)	362	290	215	60.5	25.0																						
Torque (ft-lb)	398	335	620	221	0.00																						

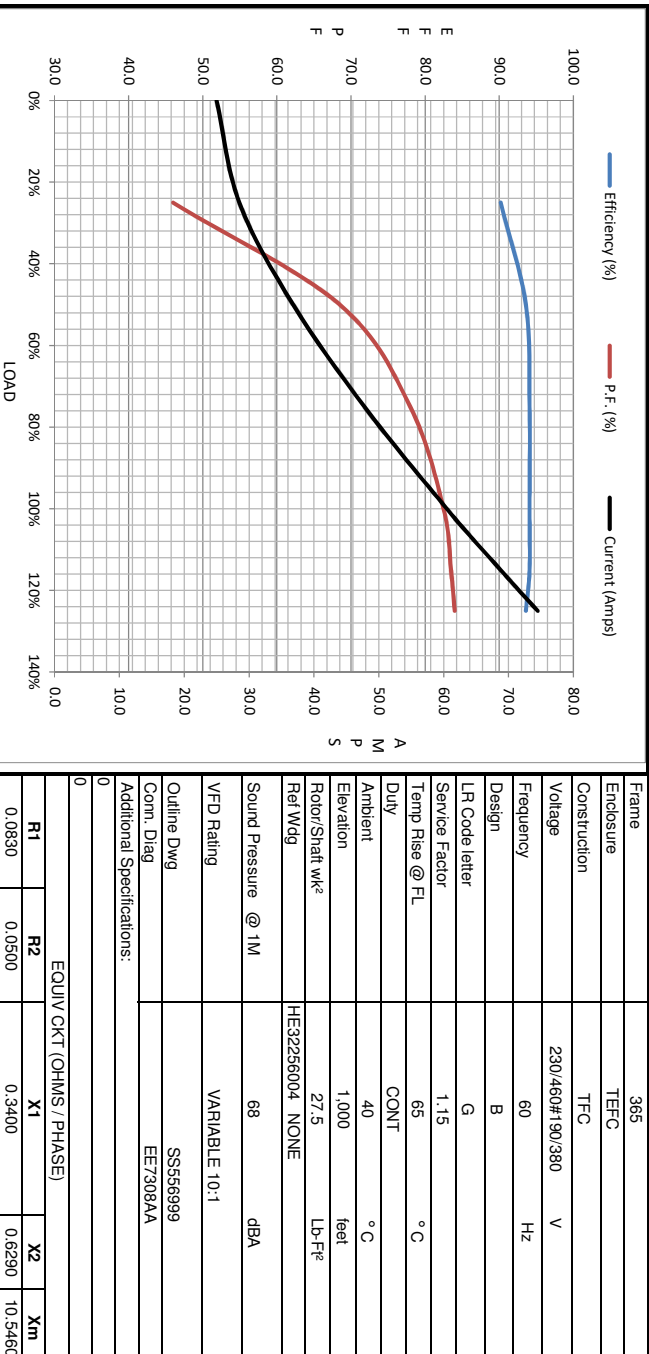

R1	R2	X1	X2	Xm
0.0830	0.0500	0.3400	0.6290	10.5460

EQUIV CKT (OHMS / PHASE)

