

PRODUCT INFORMATION PACKET



Model No: A4C17DJ57F

Catalog No: 101611.00

1/2HP..1725RPM.48.DP.115/208-230V.1PH.60HZ.CONT.AUTOMATIC.40C.1.25SF.RESILIENT BASE.

Open Drip Proof (ODP)



Regal and Leeson are trademarks of Regal Beloit Corporation or one of its affiliated companies.

©2018 Regal Beloit Corporation, All Rights Reserved. MC017097E





Nameplate Specifications

Output HP	0.50 Hp	Output KW	0.37 kW
Frequency	60 Hz	Voltage	115/208-230 V
Current	8.8/4.0-4.4 A	Speed	1725 rpm
Service Factor	1.25	Phase	1
Efficiency	62 %	Duty	Continuous
Insulation Class	B	Design Code	N
KVA Code	K	Frame	S56
Enclosure	Drip Proof	Overload Protector	Automatic
Ambient Temperature	40 °C	Drive End Bearing Size	6203
Opp Drive End Bearing Size	6203	UL	Recognized
CSA	Y	CE	N
IP Code	22		

Technical Specifications

Electrical Type	Capacitor Start Induction Run	Starting Method	Across The Line
Poles	4	Rotation	Selective Counterclockwise
Mounting	Resilient Base	Motor Orientation	HORIZONTAL
Drive End Bearing	BALL	Opp Drive End Bearing	BALL
Frame Material	Rolled Steel	Shaft Type	T
Overall Length	10.81 in	Frame Length	6.00 in
Shaft Diameter	0.625 in	Shaft Extension	1.88 in
Assembly/Box Mounting	F1 ONLY		
Outline Drawing	031623-600	Connection Diagram	005049.16

031623

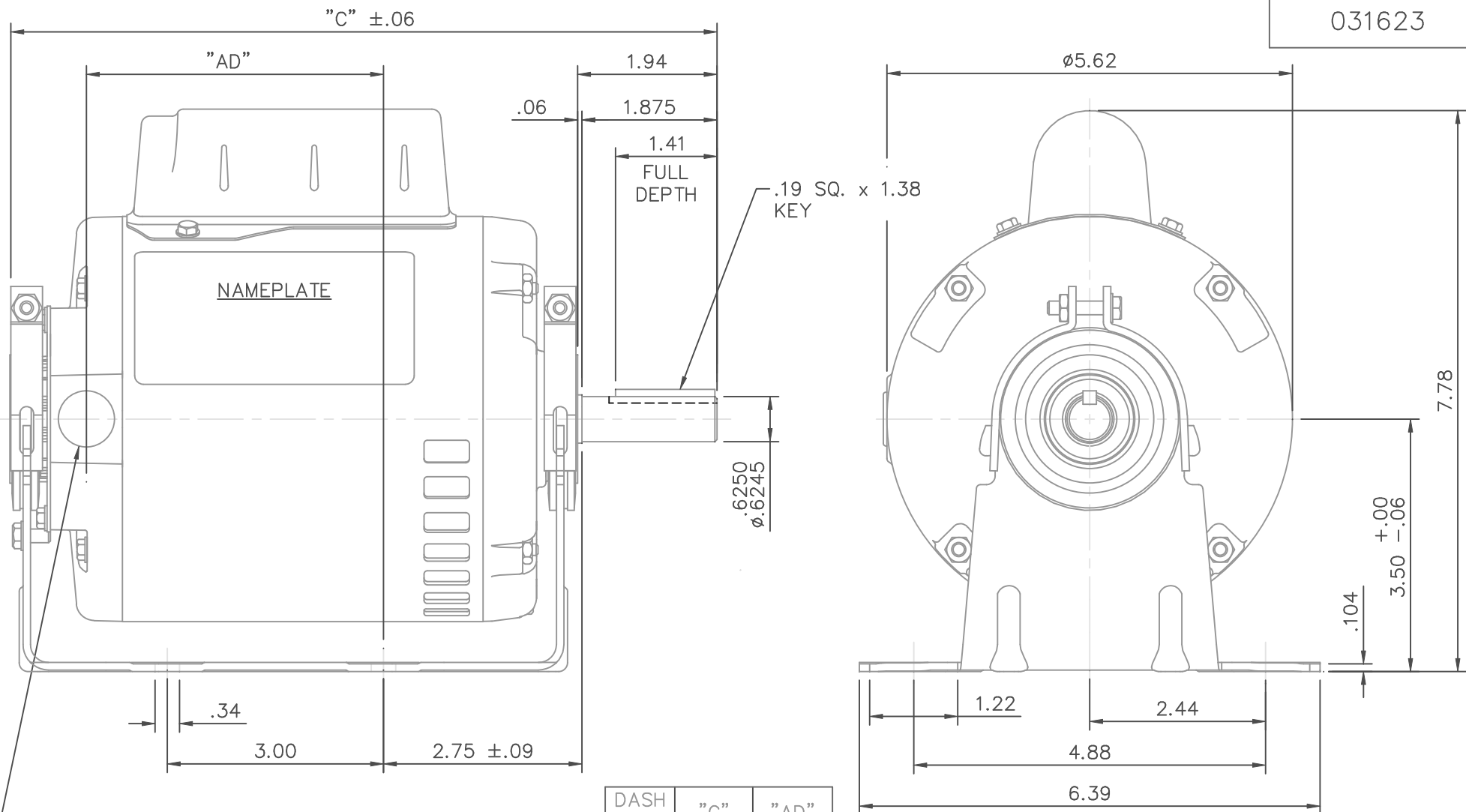

1/2-14 NPT
CONDUIT HOLE
(PLUGGED)

DASH NO.	"C"	"AD"
500	9.81	4.12
550	10.31	4.62
600	10.81	5.12
650	11.31	5.62

TOLERANCES UNLESS OTHERWISE SPECIFIED

DEC.	INCHES	METRIC
.X	±.1	±2.5
.XX	±.03	±.76
.XXX	±.005	±.127
NO.	REVISION	BY & DATE
CH'K'D.	.XXXX	±.0005 ±.0127

LEESON ELECTRIC CORPORATION

DRAWN PG 5/24/01

TITLE
OUTLINE - S56 FRAME
RESILIENT MOUNT - DRIP PROOF

APPR.

R.F.P.

MAT'L.
1 PHASE

SCALE 1=2

THIS DRAWING IN DESIGN AND DETAIL IS OUR PROPERTY AND MUST NOT BE USED EXCEPT IN CONNECTION WITH OUR WORK ALL RIGHTS OF DESIGN AND INVENTION ARE RESERVED THIS IS AN ELECTRONICALLY GENERATED DOCUMENT - DO NOT SCALE THIS PRINT

FRACTIONS ±1/64

ANGLES ±1/2°

REF. 030485

FMF 101611

FINISH

REV.

DRAWING NO.

031623

VIEW FROM OUTSIDE OF MOTOR AT SWITCH END.

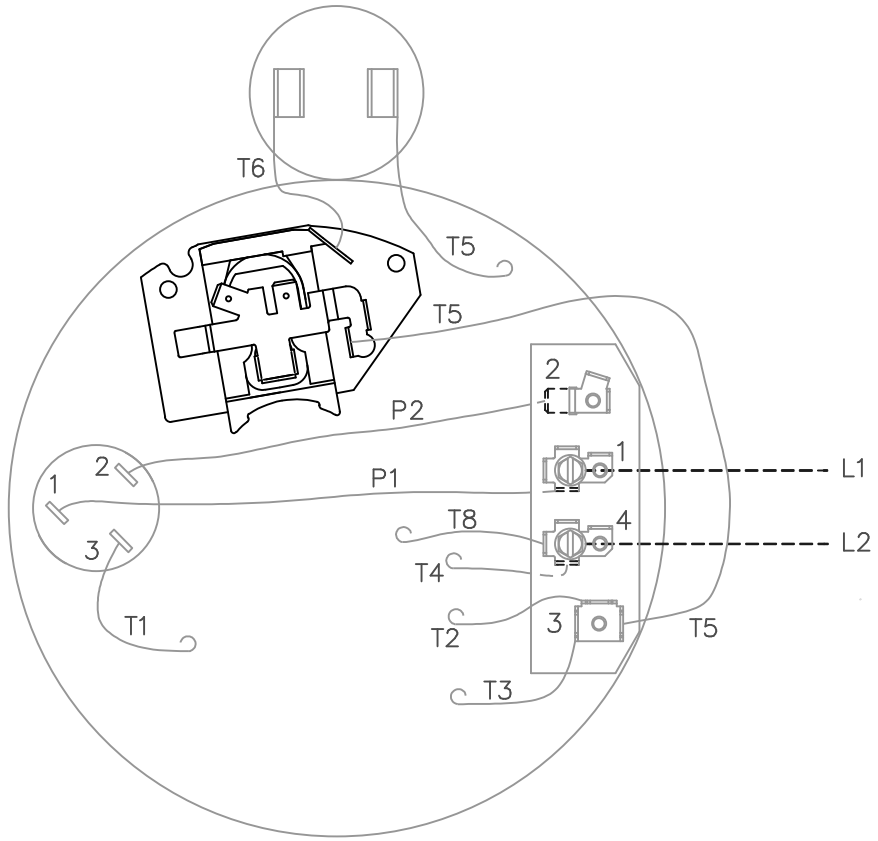

P1, P2, T4 TO GO TO
BACK SIDE OF TERMINAL BOARD

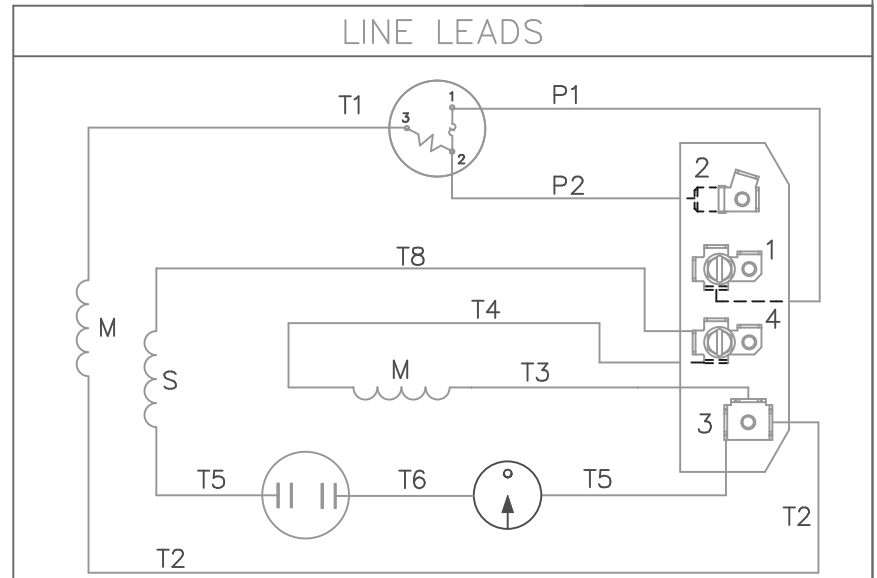

HIGH VOLTAGE
C.W.L.E. ROTATION

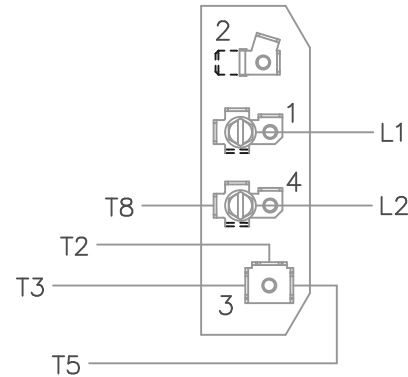

LOW VOLTAGE
C.W.L.E. ROTATION

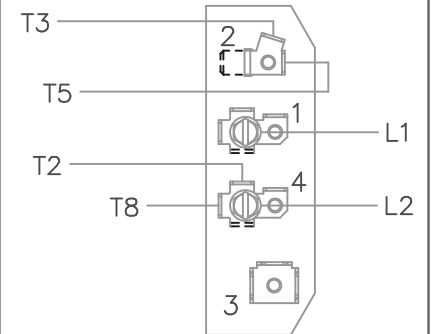

FOR C.C.W. ROTATION INTERCHANGE T5 AND T8.

				TOLERANCES UNLESS SPECIFIED		 ELECTRIC MOTORS GEARMOTORS AND DRIVES		DRAWN PG 1/31/03		
				DEC.	INCHES			CHK		
				.X	±.1			APPD		
				.XX	±.01			SCALE 1=1		
				.XXX	±.005			REF 005049-12		
				.XXXX	±.0005	MAT'L DUAL VOLTAGE - DUAL ROTATION		FMF 100204.00		
NO.	REVISION	BY & DATE	CHK	ANG	±1/2"	FINISH		PREV		
THIS DRAWING IN DESIGN AND DETAIL IS OUR PROPERTY AND MUST NOT BE USED EXCEPT IN CONNECTION WITH OUR WORK ALL RIGHTS OF DESIGN AND INVENTION ARE RESERVED THIS IS AN ELECTRONICALLY GENERATED DOCUMENT - DO NOT SCALE THIS PRINT				RFP	CAD FILE 00504916		SIZE	DRAWING NO.		REV.
				DIST			A	005049-16		



LEESON ELECTRIC CORPORATION
 TYPICAL PERFORMANCE CURVE for AC MOTOR

Model No 101611.00

Catalog No 101611.00

Curve at 230 Volts HP 0.50 PHASE 1
60 HZ
0.5 HP VOLTS 115/208-230
 HZ 60 RPM 1725

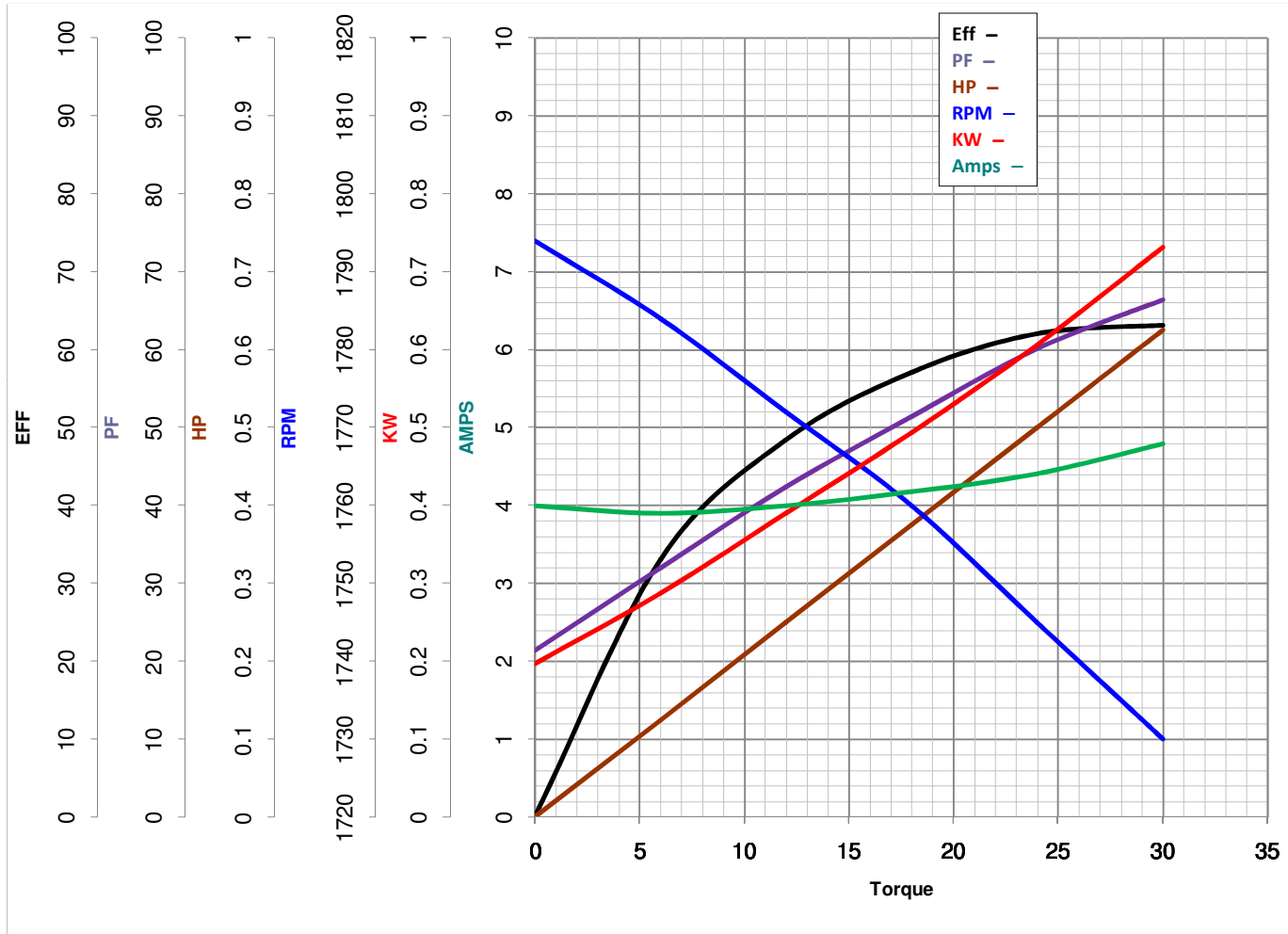

Torque in Oz.Ft

FL TORQUE 24 Oz.Ft
 BD TORQUE 66.0 Oz.Ft
 LR TORQUE 80 Oz.Ft

FL AMPS 8.8/4-4.4
 PU TORQUE 62.0 Oz.Ft
 LR AMPS 19.5

WINDING CE484206-3

Date 3/22/2018