

PRODUCT INFORMATION PACKET



Model No: 114312.00
Catalog No: 114312.00
0.50 HP Washdown Motor, 1 phase, 3600 RPM, 115/208-230 V, 56C Frame, TEFC
White Epoxy General Purpose Motors



Regal and Leeson are trademarks of Regal Beloit Corporation or one of its affiliated companies.
©2020 Regal Beloit Corporation, All Rights Reserved. MC017097E





Nameplate Specifications

Output HP	0.50 Hp	Output KW	0.37 kW
Frequency	60 Hz	Voltage	115/208-230 V
Current	7.6/4.0-3.8 A	Speed	3450 rpm
Service Factor	1.15	Phase	1
Efficiency	63 %	Power Factor	70
Duty	Continuous	Insulation Class	F
Design Code	N	KVA Code	M
Frame	56C	Enclosure	Totally Enclosed Fan Cooled
Thermal Protection	No	Ambient Temperature	40 °C
Drive End Bearing Size	6205	Opp Drive End Bearing Size	6203
UL	Recognized	CSA	Y
CE	N	IP Code	55

Technical Specifications

Electrical Type	Capacitor Start Induction Run	Starting Method	Across The Line
Poles	2	Rotation	Selective Counterclockwise
Resistance Main	4.42 Ohms	Mounting	Round
Motor Orientation	Horizontal	Drive End Bearing	Ball
Opp Drive End Bearing	Ball	Frame Material	Rolled Steel
Shaft Type	NEMA 56	Overall Length	10.62 in
Frame Length	4.75 in	Shaft Diameter	0.625 in
Shaft Extension	1.88 in	Assembly/Box Mounting	F1 ONLY
Connection Drawing	005278.07	Outline Drawing	607-0010-475A

This is an uncontrolled document once printed or downloaded and is subject to change without notice. Date Created:14/10/2020

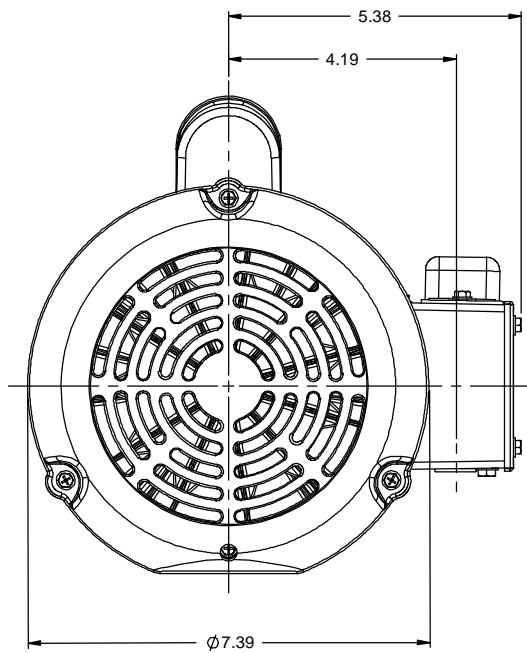

**WITH SHORTER FRAME LENGTHS PLACE THESE DECALS ON OPPOSITE SIDE OF MOTOR NEXT TO NAMEPLATE.

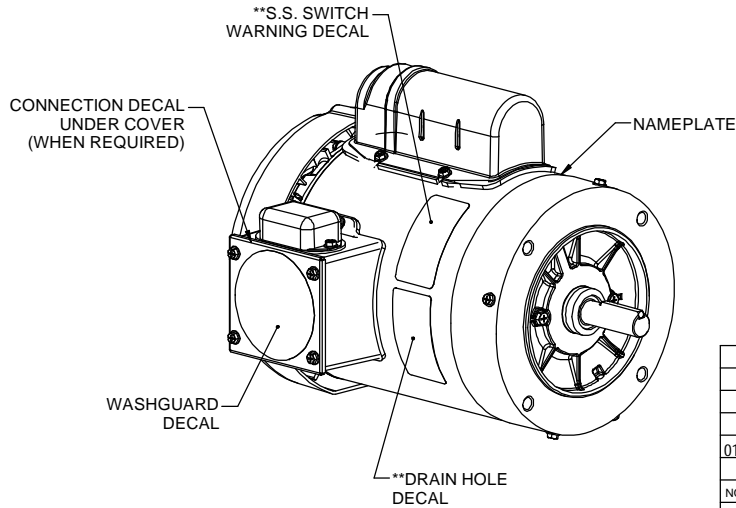
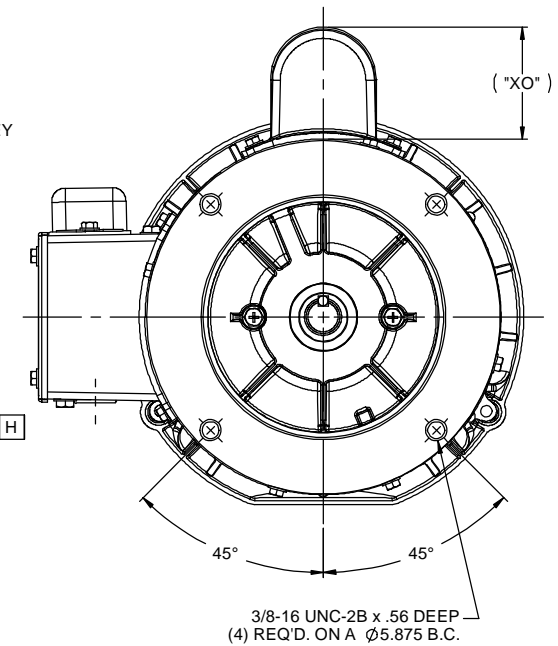
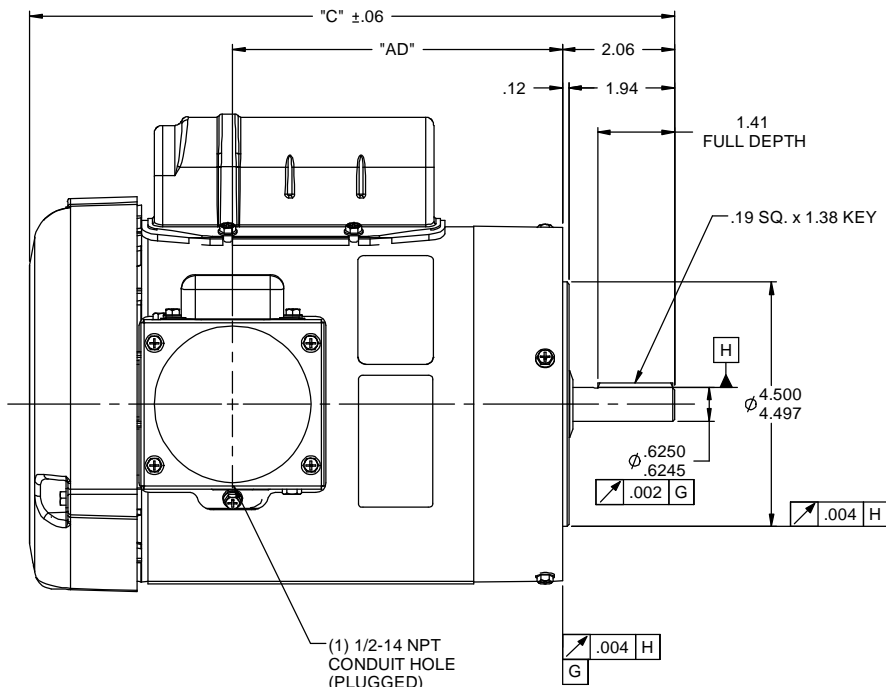

DASH NO	"C"	"AD"	"XO"	DASH NO	"C"	"AD"	"XO"
** 450A	10.37	4.56	2.00	** 450B	10.37	4.56	2.25
** 475A	10.62	4.81	2.00	** 475B	10.62	4.81	2.25
500A	10.87	5.06	2.00	500B	10.87	5.06	2.25
525A	11.12	5.31	2.00	525B	11.12	5.31	2.25
550A	11.37	5.56	2.00	550B	11.37	5.56	2.25
575A	11.62	5.81	2.00	575B	11.62	5.81	2.25
600A	11.87	6.06	2.00	600B	11.87	6.06	2.25
625A	12.12	6.31	2.00	625B	12.12	6.31	2.25
650A	12.37	6.56	2.00	650B	12.37	6.56	2.25
700A	12.87	7.06	2.00	700B	12.87	7.06	2.25
750A	13.37	7.56	2.00	750B	13.37	7.56	2.25
800A	13.87	8.06	2.00	800B	13.87	8.06	2.25

WASHGUARD MOTOR

- SPECIAL FEATURES:
1. SHAFT SEAL & V-RING.
 2. PLUGGED DRAIN HOLES IN ENDBELLS & CONDUIT BOX.
 3. BUNA-N GASKETS THROUGHOUT.
 4. STAINLESS STEEL SHAFT, HARDWARE & NAMEPLATE.
 5. SOLID STATE SWITCH MOUNTED TO CONDUIT BOX.

		TOLERANCES UNLESS SPECIFIED			ELECTRIC MOTORS GEARMOTORS AND DRIVES	DRAWN PG 02/10/11
		DEC	INCHES			CHK
		X	±.1			APPR
		XX	±.03	TITLE OUTLINE - 56C FRAME		SCALE 7:16
		XXX	±.005	TEFC - "C" FACE		REF 028866
01	ADDED NOTE FOR LOCATION OF DECALS ON SHORTER FRAME MOTORS ISAAC 12-3707	GS	8/2/12	XXXX	±.0005	MATL WASHGUARD
NO	REVISION	BY & DATE	CHK	ANG	±1/2"	FINISH
				RFP		PREV
				NETWORK FILE NAME 607-0010		SIZE B
						DRAWING NO 607-0010
						REV 01



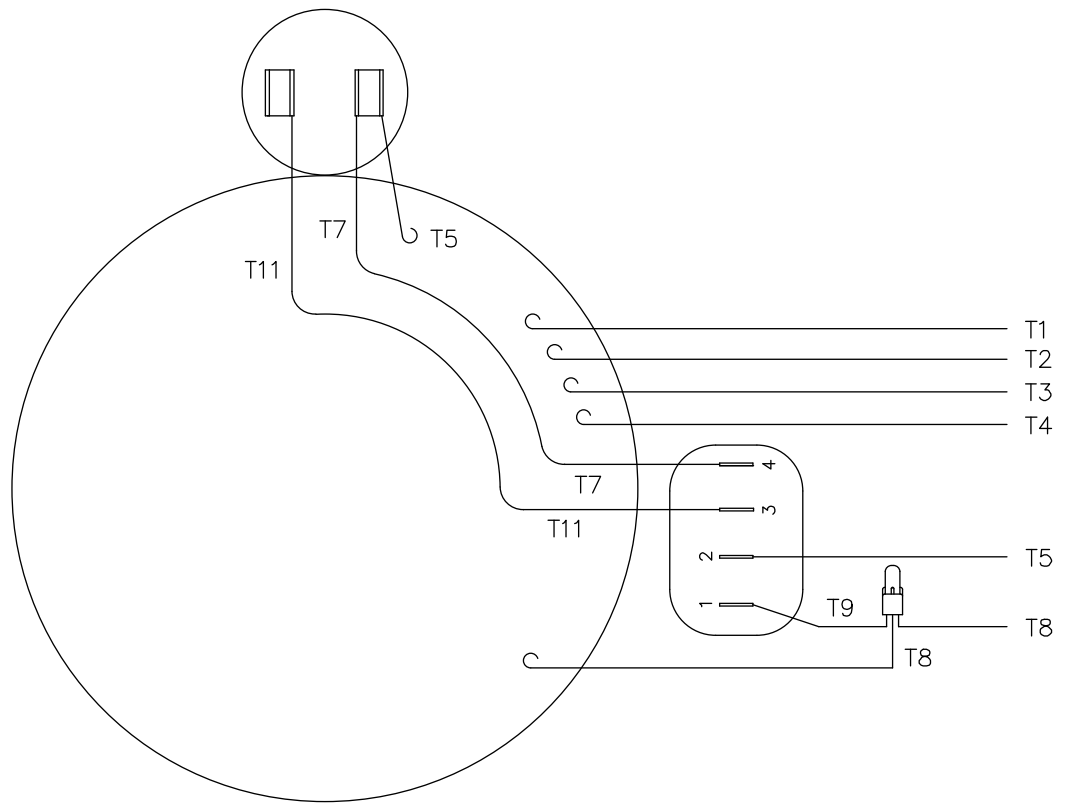

VIEW FROM OUTSIDE OF MOTOR AT SWITCH END.

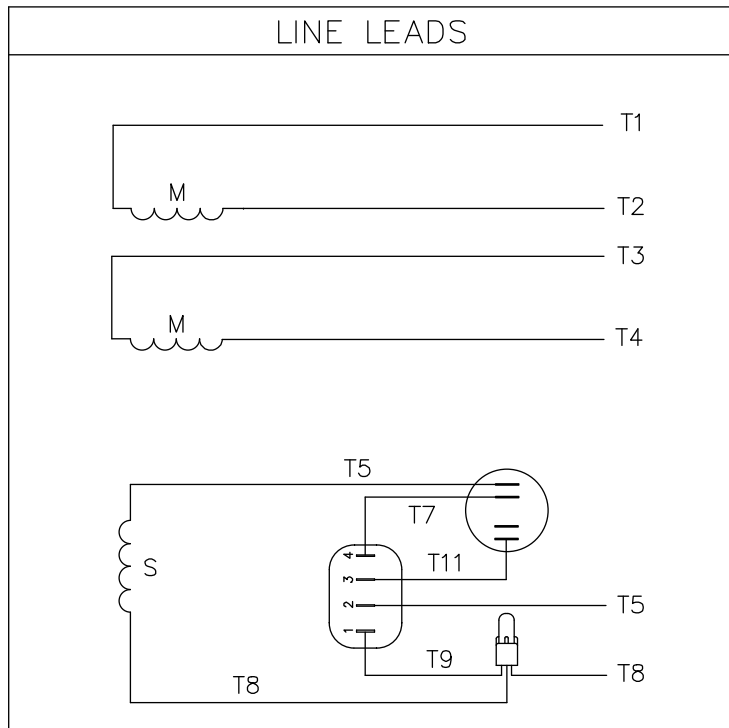

	ROTATION FACING LEAD END	L1	L2	JOIN & INSULATE
HIGH VOLT	C.C.W.	T1	T4 T5	T2, T3 T8
	C.W.	T1	T4 T8	T2, T3 T5
LOW VOLT	C.C.W.	T1, T3 T8	T2, T4 T5	
	C.W.	T1, T3 T5	T2, T4 T8	

				TOLERANCES UNLESS OTHERWISE SPECIFIED		LEESON ELECTRIC CORPORATION				
				DECIMALS						
				.00	± .01	DRAWN	TITLE			
				.000	± .005	CH'K'D.	EXTERNAL WIRING DIAGRAM TYPE "C" W/O PROTECTOR			
01	ADDED DECAL FOR STOCK MOTORS ECR 0042509	GWS	9/10/13	.0000	± .0005	APPR.	MAT'L. DECAL - 004012			
NO.	REVISION	BY	DATE	FRACTIONS	± 1/64	SCALE	STOCK MOTORS TO USE DECAL 214-0122-001			
THIS DRAWING IN DESIGN AND DETAIL IS OUR PROPERTY AND MUST NOT BE USED EXCEPT IN CONNECTION WITH OUR WORK ALL RIGHTS OF DESIGN AND INVENTION ARE RESERVED				ANGLES	± 1/2*	REF.	005278-01	FINISH	SIZE	DRAWING NO.
				INCH/MM		FMF	131571	STANDARD	A	005278-07



1051 CHEYENNE AVE.
GRAFTON, WI 53024
PH. 262-377-8810

CERTIFICATION DATA SHEET

CONN. DIAGRAM: 005278.07
OUTLINE: 607-0010-475A
WINDING #: C632209 FR 3 A

CATALOG #: 114312.00
MOUNTING: F1 ONLY

TYPICAL MOTOR PERFORMANCE DATA

HP	KW	SYNC. RPM	F.L. RPM	FRAME	ENCLOSURE	KVA CODE	DESIGN
1/2	0.37	3600	3450	56C	TEFC	M	N

PH	Hz	VOLTS	AMPS	START TYPE	DUTY	INSL	S.F.	AMB°C
1	60	115/208-230	7.6/4-3.8	ACROSS THE LINE	CONTINUOUS	F4	1.15	40

FULL LOAD EFF:		63	3/4 LOAD EFF:	59.3	1/2 LOAD EFF:	51.1	GTD. EFF	ELEC. TYPE
FULL LOAD PF:		70	3/4 LOAD PF:	61.6	1/2 LOAD PF:	51.6	59.5	CAP START IND RUN

F.L. TORQUE		LOCKED ROTOR AMPS	L.R. TORQUE	B.D. TORQUE	F.L. RISE°C		
12.09	OZ-FT	44 / 22	45	OZ-FT 375 %	32	OZ-FT 267 %	110

SOUND PRESSURE @ 3 FT.		SOUND POWER	ROTOR WK^2	MAX. WK^2	SAFE STALL TIME	STARTS / HOUR	APPROX. MOTOR WGT		
0	DBA	10	DBA	0.03	LB-FT^2	0	SEC. 0	28	LBS.

*** SUPPLEMENTAL INFORMATION ***

DE BRACKET TYPE	ODE BRACKET TYPE	MOUNT TYPE	ORIENTATION	SEVERE DUTY	HAZARDOUS LOCATION	DRIP COVER	SCREENS	PAINT
C-FACE	STANDARD	ROUND	HORIZONTAL	FALSE	NONE	FALSE	NONE	WHITE - LEESON (EPOXY)

BEARINGS		GREASE	SHAFT TYPE	SPECIAL DE	SPECIAL ODE	SHAFT MATERIAL	FRAME MATERIAL
DE	ODE						
BALL	BALL	POLYREX EM	STANDARD 56	NONE	NONE	303 STAINLESS (C-501)	ROLLED STEEL
6205	6203						

THERMO-PROTECTORS							
THERMOSTATS	PROTECTORS	WDG RTDs	BRG RTDs	TERMISTORS	CONTROL	SPACE HEATERS	VOLTS
NONE	NOT	NONE	NONE	NONE	FALSE	NONE	NONE

INVERTER TORQUE: NONE
INV. HP SPEED RANGE: NONE

ENCODER: NONE
NONE NONE
NONE NONE PPR

BRAKE: NONE NONE
NONE P/N NONE
NONE NONE
FT-LB V NONE HZ

*
N
O
T
E
S
*



LEESON ELECTRIC CORPORATION
 TYPICAL PERFORMANCE CURVE for AC MOTOR

Model No 114312.00

Catalog No 114312.00

Curve at 230 Volts HP 0.50 PHASE 1
60 HZ
0.5 HP VOLTS 115/208-230

HZ 60 RPM 3450

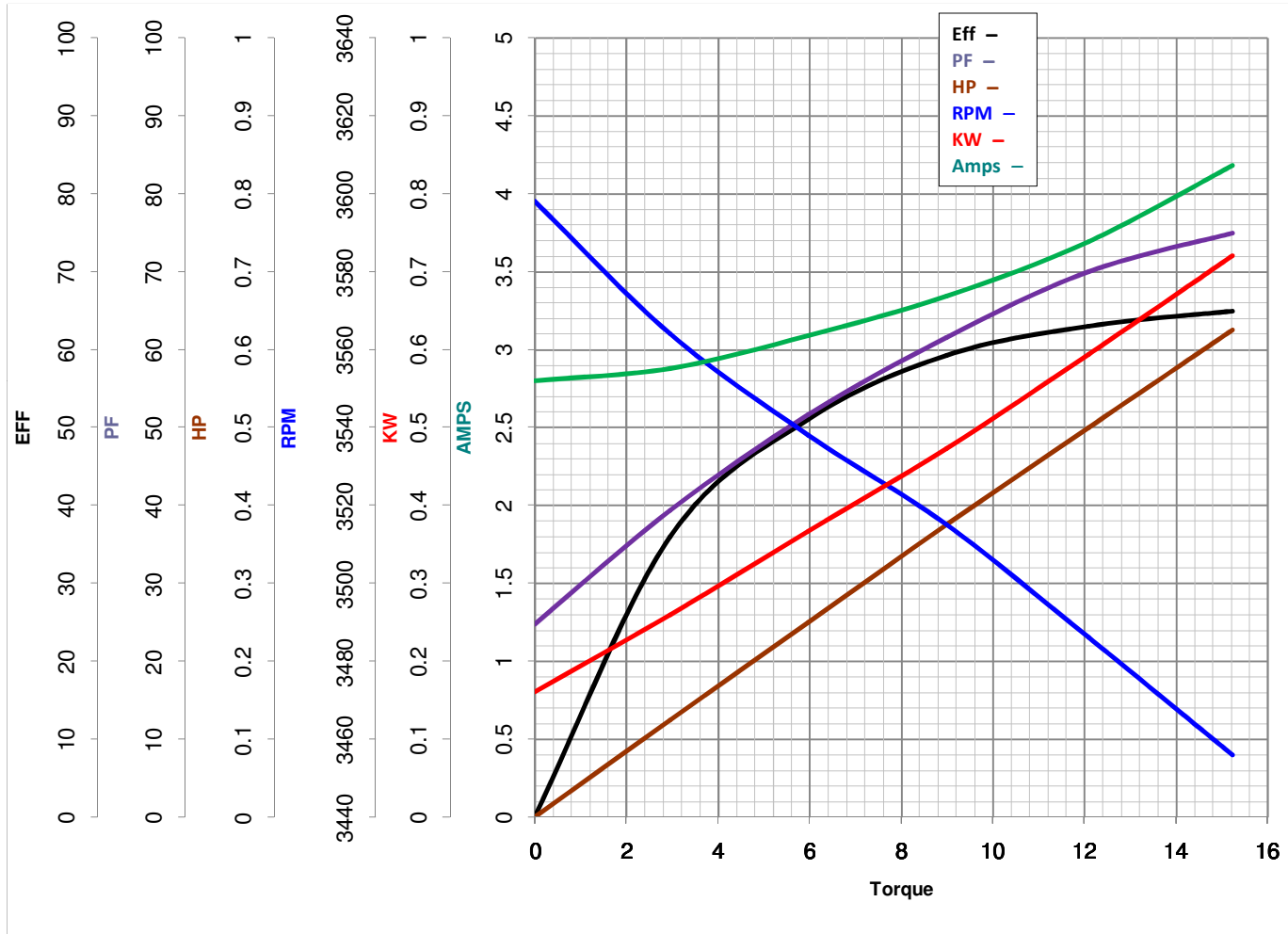

Torque in Oz.Ft

FL TORQUE 12.09 Oz.Ft
 BD TORQUE 32.0 Oz.Ft
 LR TORQUE 45 Oz.Ft

FL AMPS 7.6/4-3.8
 PU TORQUE 32.0 Oz.Ft
 LR AMPS 22

WINDING C632209-3

Date 4/12/2018