

**/// MLD-UDC**



MLD 500Transceiver or transmitter-receiver systems with different numbers of beams and ranges which are pre-mounted in device columns facilitate the installation of the most diverse constructional systems even in combination with deflecting mirror columns. They are suitable for single- and multiple-sided access guarding.

**Benefits:**

- Pre-mounted safety sensors in sturdy device columns
- Configuration without PC via wiring in the switch cabinet
- Extremely diverse access guarding systems with the addition of deflecting mirror columns
- All columns with automatic resetting after mechanical impacts
- Also for low-temperature applications down to -30 °C

| Part no. | Part description          | Beam spacing | Number of beams | Operating range | Column height without foot | Design  |
|----------|---------------------------|--------------|-----------------|-----------------|----------------------------|---|
| 426379   | ► MLD510-R2-UDC-1000-S2-P | 500 mm       | 2x              |                 | 1,000 mm                   | Protective screen   |
| 426345   | ◄ MLD500-T2-UDC-1000-S2-P | 500 mm       | 2x              | 0.5 ... 50 m    | 1,000 mm                   | Protective screen   |
| 426415   | ► MLD510-R2L-UDC-1000-S2  | 500 mm       | 2x              |                 | 1,000 mm                   | Reflective element for laser alignment aid                              |
| 426306   | ◄ MLD500-T2L-UDC-1000-S2  | 500 mm       | 2x              | 0.5 ... 50 m    | 1,000 mm                   | Integrated laser alignment aid  |
| 426308   | ► MLD520-R2L-UDC-1000-S2  | 500 mm       | 2x              |                 | 1,000 mm                   | Reflective element for laser alignment aid                              |
| 426306   | ◄ MLD500-T2L-UDC-1000-S2  | 500 mm       | 2x              | 0.5 ... 50 m    | 1,000 mm                   | Integrated laser alignment aid  |
| 426307   | ► MLD530-R2LM-UDC-1000-S2 | 500 mm       | 2x              |                 | 1,000 mm                   | Integrated muting indicator, reflective element for laser alignment aid |
| 426306   | ◄ MLD500-T2L-UDC-1000-S2  | 500 mm       | 2x              | 0.5 ... 50 m    | 1,000 mm                   | Integrated laser alignment aid  |
| 426535   | ► MLD530-RT2M-UDC-1000-S2 | 500 mm       | 2x              | 0.5 ... 8 m     | 1,000 mm                   | Integrated muting indicator   |
| 426305   | ◄ MLD-M002-UDC-1000-S2    | 500 mm       | 2x              |                 | 1,000 mm                   |   |
| 426599   | ► MLD510-XR3L-UDC-1140-S2 | 400 mm       | 3x              |                 | 1,140 mm                   | Reflective element for laser alignment aid                              |
| 426598   | ◄ MLD500-XT3L-UDC-1140-S2 | 400 mm       | 3x              | 20 ... 70 m     | 1,140 mm                   | Integrated laser alignment aid  |
| 426542   | ► MLD520-RT3-UDC-1300-S2  | 400 mm       | 3x              | 0.5 ... 6 m     | 1,300 mm                   |   |
| 905067   | ◄ MLD-M003-UDC-1300-S2    | 400 mm       | 3x              |                 | 1,300 mm                   |   |
| 426549   | ► MLD530-RT3M-UDC-1300-S2 | 400 mm       | 3x              | 0.5 ... 6 m     | 1,300 mm                   | Integrated muting indicator<br>Integrated status indicator              |
| 905067   | ◄ MLD-M003-UDC-1300-S2    | 400 mm       | 3x              |                 | 1,300 mm                   |   |
| 426536   | ► MLD520-RT3-UDC-1600-S2  | 400 mm       | 3x              | 0.5 ... 6 m     | 1,600 mm                   |   |
| 905068   | ◄ MLD-M003-UDC-1600-S2    | 400 mm       | 3x              |                 | 1,600 mm                   |   |
| 426537   | ► MLD535-RT3M-UDC-1600-S2 | 400 mm       | 3x              | 0.5 ... 6 m     | 1,600 mm                   | Integrated muting indicator   |
| 905068   | ◄ MLD-M003-UDC-1600-S2    | 400 mm       | 3x              |                 | 1,600 mm                   |   |
| 426544   | ► MLD535-RT3M-UDC-1900-S2 | 400 mm       | 3x              | 0.5 ... 6 m     | 1,900 mm                   | Integrated muting indicator<br>Integrated status indicator              |
| 426508   | ◄ MLD-M003-UDC-1900-S2    | 400 mm       | 3x              |                 | 1,900 mm                   |   |

► receiver or Transceiver / ◄ transmitter or mirror  
 Included in delivery: mounting kit for floor assembly.  
 Further products of this series can be found on our website or on request.

**Dimensioned drawings: MLD-UDC**

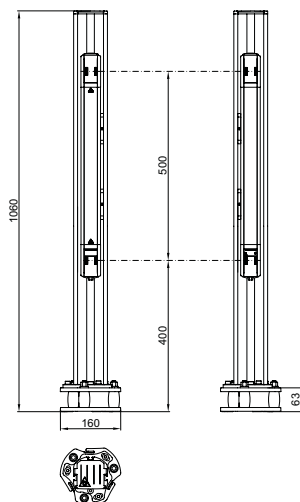

MLD500-T2L-UDC1000-S2 protective sensor set (transmitter) /  
 MLD520R2L-UDC1000-S2 (receiver)

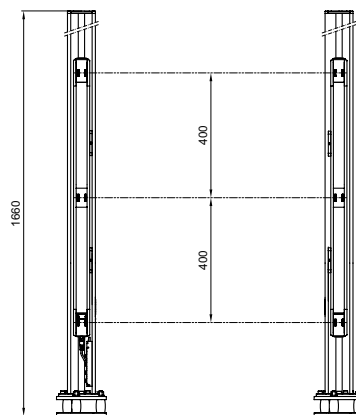

MLD535-RT3M-UDC-1600-S2 protective sensor set (transceiver) /  
 MLD-M003-UDC-1600-S2 (deflecting mirror)