



Part no.: 50117255
BTU 200M-D12
Mounting system



Figure can vary

Contents

- Technical data
- Dimensioned drawings
- Accessories



Part no.: 50117255 – BTU 200M-D12 – Mounting system

Technical data

Basic data

Contains	2x M3 x 18 screw 2x position washers
Suitable for	18 series sensors 25B series sensors 28 series sensors 3B series sensors 5 series sensors 55 series sensors

Mechanical data

Standard designation, metal mounting device	Steel, galvanized Aluminum
Design of mounting device	Mounting system
Type of fastening, at system	Sheet-metal mounting For 12 mm rod
Type of fastening, at device	Screw type
Type of mounting device	Adjustable Turning, 360° Clampable
Mounting device material	Metal

Classification

eCl@ss 8.0	27279202
eCl@ss 9.0	27273701

Dimensioned drawings

All dimensions in millimeters

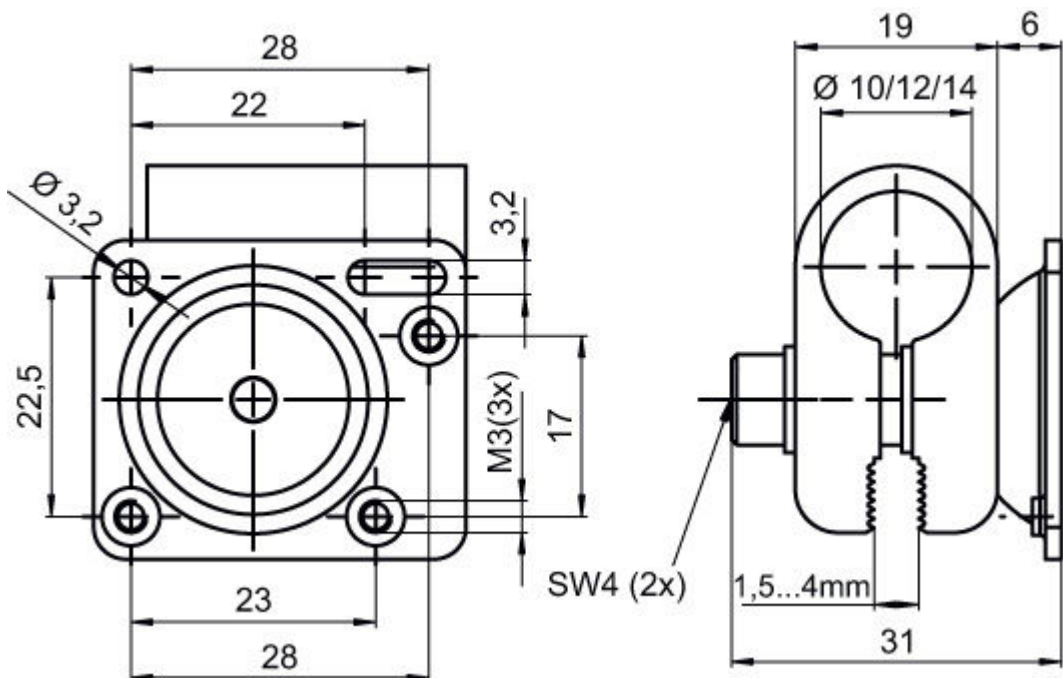

Part no.: 50117255 – BTU 200M-D12 – Mounting system

Accessories

Micro-triad-type reflectors

	Part no.	Designation	Article	Description
	50040895	MTKS 20x20	Reflector	Design: Rectangular Reflective surface: 20 mm x 20 mm Material: Plastic Base material: Plastic Chemical designation of the material: PMMA8N Fastening: Through-hole mounting, Adhesive