

**Dimensioned drawing**

en 02-2014/08 50117995



- Universal sensor rod mounting  $\varnothing$  10mm,  $\varnothing$  12mm or  $\varnothing$  14mm
- Precise sensor alignment via 2-stage mounting
- Alignment on all 3 levels
- Compact design
- Stable metal design
- Fast installation via pre-mounted unit

We reserve the right to make changes • DS\_AccessoryBTU\_en\_50117995.fm

**BTU 200M...**

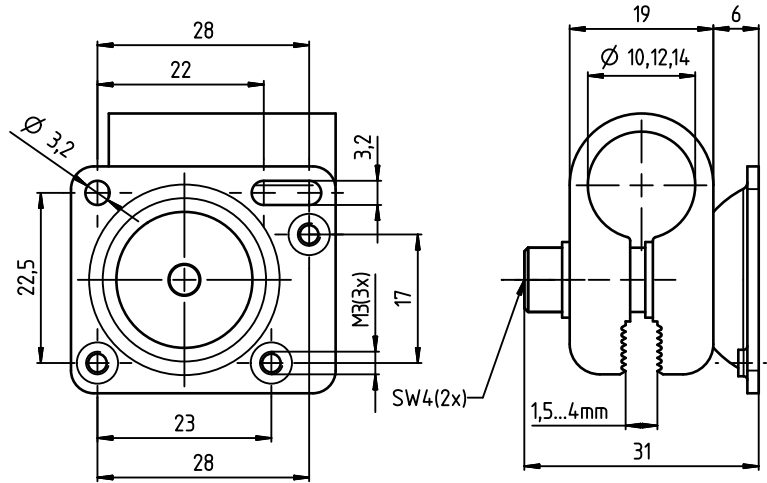

**BTU 300M...**

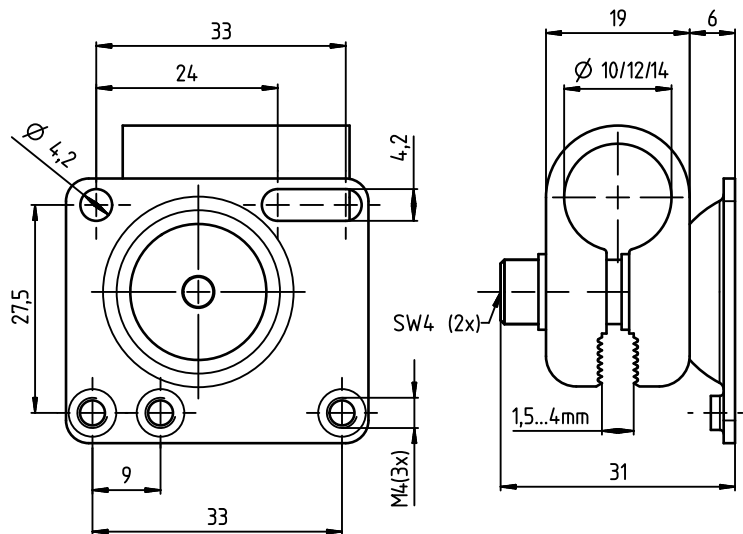

**Tightening torque:**

- Screw terminals M5 < 2.8Nm !**
- Sensor fastening M4 < 1.4Nm !**
- Sensor fastening M3 < 0.9Nm !**

## Specifications

### General Specifications

Rod mounting

BTU 200M...  
 Ø 10mm  
 Ø 12mm  
 Ø 14mm

BTU 300M...  
 Ø 10mm  
 Ø 12mm  
 Ø 14mm

Suitable for sensors

BTU 200M...  
 3B Series  
 5 Series  
 18 Series  
 25B Series  
 28 Series  
 55 Series

BTU 300M...  
 8 Series  
 9 Series  
 46B Series

### Mechanical data

Material

Clamp: aluminum diecast  
 Sensor holder: zinc-plated steel

Tightening torque<sup>1)</sup>

Screw terminals M5 (SW 4):	max. 2.8Nm
Sensor fastening M4 (SW 3):	max. 1.4Nm
Sensor fastening M3 (SW 2.5):	max. 0.9Nm

1) Screw mounted with washer

## Mounting

1. Select mounting location on the rod and clamp mounting device.
2. Align sensor exactly and fasten.

## Order guide

Sensor series	Rod	Designation	Part No.
3B, 5, 18, 25B, 28, 55	Ø 10mm	BTU 200M-D10	50117256
	Ø 12mm	BTU 200M-D12	50117255
	Ø 14mm	BTU 200M-D14	50117254
8, 9, 46B	Ø 10mm	BTU 300M-D10	50117253
	Ø 12mm	BTU 300M-D12	50117252
	Ø 14mm	BTU 300M-D14	50117251

## Remarks

### Operate in accordance with intended use!

- ↪ The product may only be put into operation by competent persons.
- ↪ Only use the product in accordance with the intended use.