

SMART
SENSOR
BUSINESS

GS 754B CCD Forked Photoelectric Sensors

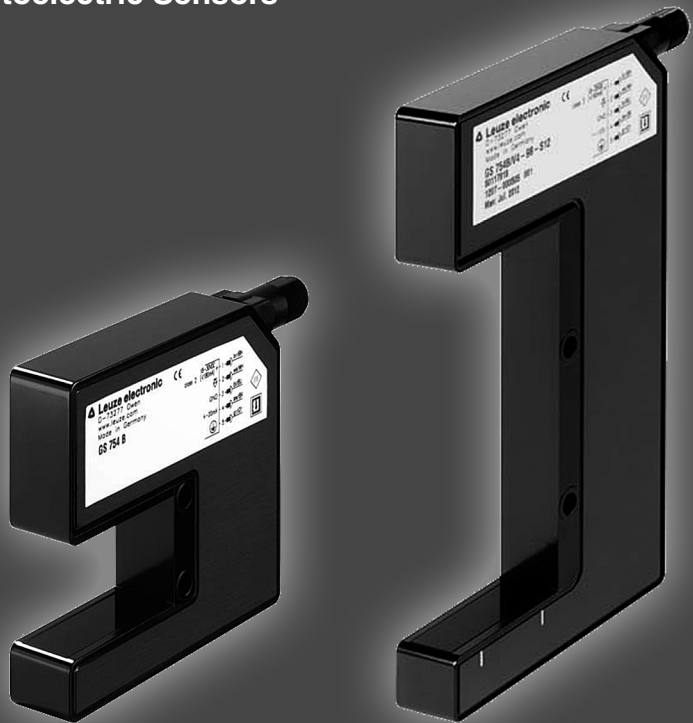

EN 04-2017/01 50112717
We reserve the right to
make technical changes

1	About this document.	3
1.1	Explanation of symbols	3
2	Safety	4
2.1	Intended use	4
2.2	Foreseeable misuse	5
2.3	Competent persons	5
2.4	Disclaimer	6
3	Controls and indicators.	7
4	Device description	8
4.1	General information	8
4.2	Optical data	8
4.3	LED indicators	9
5	Applications	10
5.1	Diameter determination	10
5.1.1	ASCII representation via RS 232 (P and M12 interfaces)	11
5.1.2	Binary representation via RS 232 (P and M12 interfaces)	11
5.2	Edge measurement and height verification	12
5.3	Width measurement	13
6	Device configuration.	14
6.1	General information	14
6.2	Terminal program	14
6.2.1	Basic configuration of the terminal program (interface P)	14
6.3	Configuration of the measurement, analysis and output procedures over interface P	15
6.3.1	Configuration table for GS 754B	15
6.4	Special configurations	17
6.4.1	Edge measurement for perforated objects	17
6.4.2	Changeover of the edge assignment for single-object measurement	18
6.4.3	PIN 2 as a teach input	19
6.4.3.1	<i>Teach-in in the middle of the measurement field</i>	19
6.4.3.2	<i>Teach-in at the end of the measurement field</i>	19
6.4.3.3	<i>Teach-in at the start of the measurement field</i>	20
6.4.4	PIN 2 as a synchronization / trigger input	20
6.4.5	PIN 2 as an activation input	20

6.4.6	PIN 2 as a switching output	21
6.4.6.1	Standard function	21
6.4.6.2	Standard function, inverted	22
6.4.6.3	Photoelectric sensor function, dark switching	22
6.4.6.4	Photoelectric sensor function, light switching	22
7	Measurement range and resolution	23
7.1	Analog measurement value output (interface M12)	23
7.2	Digital measurement value output (P and M 12 interfaces)	24
7.2.1	ASCII format for P and M12 interfaces	25
7.2.2	Binary format for the P and M12 interfaces	26
8	Error messages (P and M12 interfaces)	29
9	Service and support	29
10	Specifications	30
10.1	Optical data	30
10.2	Timing	30
10.3	Electrical data	30
10.4	Output signals	31
10.5	Mechanical data	31
10.6	Environmental data	32
11	Order guide and accessories	33
11.1	Order guide	33
11.2	Accessories	33
11.2.1	Connection cables	33
11.2.2	Configuration cable	33
12	Declaration of conformity	34

1 About this document

This technical description contains information regarding the proper use of the GS 754B measuring CCD forked photoelectric sensors.

1.1 Explanation of symbols

The symbols used in this technical description are explained below.



Attention

This symbol precedes text messages which must strictly be observed. Failure to comply with this information results in injuries to personnel or damage to the equipment.



Notice

This symbol indicates text passages containing important information.

2 Safety

This sensor was developed, manufactured and tested in line with the applicable safety standards. It corresponds to the state of the art.

2.1 Intended use

In connection with a connected control system or evaluation unit, GS 754B CCD forked photoelectric sensors are used to detect and measure small objects in industrial production processes.

Areas of application

The GS 754B CCD forked photoelectric sensor is designed especially for the following fields of application:

- Diameter determination
- Edge measurement and height verification
- Width measurement



CAUTION

Observe intended use!

- ↳ Only operate the device in accordance with its intended use.
The protection of personnel and the device cannot be guaranteed if the device is operated in a manner not complying with its intended use.
Leuze electronic GmbH + Co. KG is not liable for damages caused by improper use.
- ↳ Read the technical description before commissioning the device.
Knowledge of this technical description is an element of proper use.

NOTICE

Comply with conditions and regulations!

- ↳ Observe the locally applicable legal regulations and the rules of the employer's liability insurance association.



Attention

For UL applications, use is only permitted in class 2 circuits in accordance with the NEC (National Electric Code).

2.2 Foreseeable misuse

Any use other than that defined under "Intended use" or which goes beyond that use is considered improper use.

In particular, use of the device is not permitted in the following cases:

- Rooms with explosive atmospheres
- As stand-alone safety component in accordance with the machinery directive ¹⁾
- Operation for medical purposes

NOTICE

Do not modify or otherwise interfere with the device.

- ↳ Do not carry out modifications or otherwise interfere with the device.
The device must not be tampered with and must not be changed in any way.
The device must not be opened. There are no user-serviceable parts inside.
Repairs must only be performed by Leuze electronic GmbH + Co. KG.

2.3 Competent persons

Connection, mounting, commissioning and adjustment of the device must only be carried out by competent persons.

Prerequisites for competent persons:

- They have a suitable technical education.
- They are familiar with the rules and regulations for occupational safety and safety at work.
- They are familiar with the technical description of the device.
- They have been instructed by the responsible person on the mounting and operation of the device.

Certified electricians

Electrical work must be carried out by a certified electrician.

Due to their technical training, knowledge and experience as well as their familiarity with relevant standards and regulations, certified electricians are able to perform work on electrical systems and independently detect possible dangers.

In Germany, certified electricians must fulfill the requirements of accident-prevention regulations BGV A3 (e.g. electrician foreman). In other countries, there are respective regulations that must be observed.

1) Use as safety-related component within the safety function is possible, if the component combination is designed correspondingly by the machine manufacturer.

2.4 Disclaimer

Leuze electronic GmbH + Co. KG is not liable in the following cases:

- The device is not being used properly.
- Reasonably foreseeable misuse is not taken into account.
- Mounting and electrical connection are not properly performed.
- Changes (e.g., constructional) are made to the device.

3 Controls and indicators

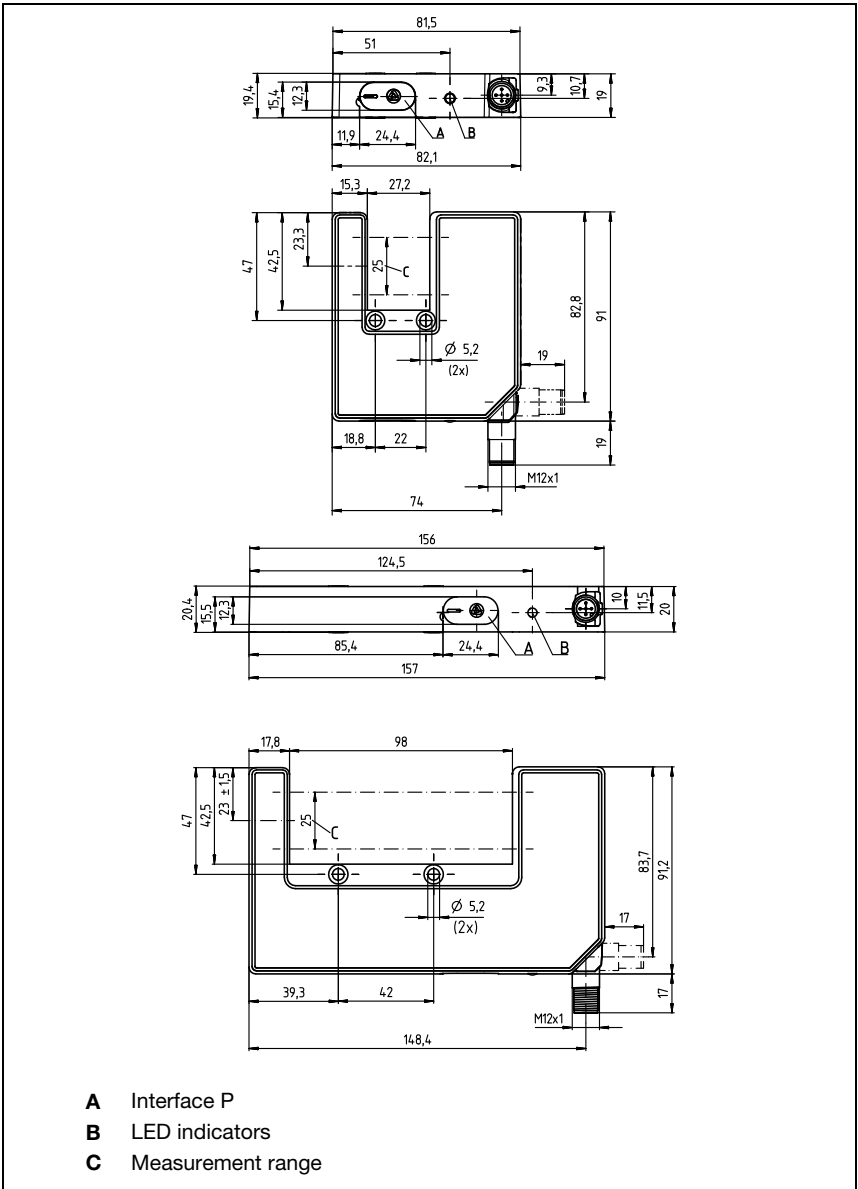

Figure 3.1: Positioning of the controls and indicators

4 Device description

4.1 General information

The central part of the unit is an optical sensor that generates a horizontal band of light (figure 3.1). The band of light illuminates a CCD line array camera. This CCD array produces an output signal that depends on the number of illuminated pixels.

The system has a permanent calibration and guarantees maximum precision and stability at all times.

Every sensor features two interfaces (see figure 3.1).

1. Interface P (RS 232):
programming interface for configuring the measurement modes and for visualizing the measurement values.
2. Interface M12 (process interface):
data for the control system are transmitted via this interface. Depending on the device model used, the measurement values are output either as an analog current/voltage signal or as digital, serial information (RS 232, RS 422).

Depending on the device model used, not all measurement values are available at the P and M12 interfaces:

- The analog interface can only output one measurement value at a time.
- The digital interface can transmit any number of measurement values.

4.2 Optical data

	GS 754B	
	Output modes 1 ... 5	Output mode 7 (default)
Measurement range	25 mm	25 mm
Mouth width	27 mm/98 mm	27 mm/98 mm
Mouth depth	42 mm	42 mm
Resolution	≤ 0.1 mm over the entire measurement range	≥ 0.014 mm per measurement level
Smallest object	≥ 0.5 mm	≥ 0.5 mm
Light source	infrared LED	infrared LED
Wavelength	850 nm	850 nm

Table 4.1: Optical data

4.3 LED indicators

LED	Meaning
green, continuous light	Ready
green, flashing	Interference

Table 4.2: LED indicators

5 Applications

5.1 Diameter determination

Depending on which interface is used, data for up to three objects can be output. Data for more than one object can only be transmitted via the serial interface. The analog value is always based on the edge or diameter information.

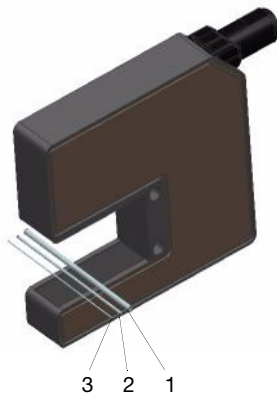

Figure 5.1: Diameter determination application example

5.1.1 ASCII representation via RS 232 (P and M12 interfaces)

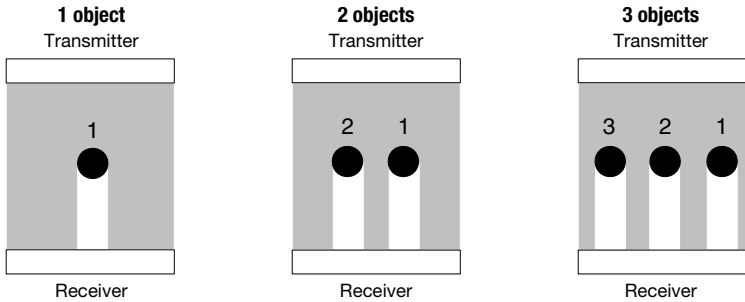

Figure 5.2: Diameter determination - Detection of 1, 2 or 3 objects

Parameter		ASCII output data via S1 and S2
Q,q	Single-object detection	Middle pos. : xxx Diameter: xxx
W,w	Detection of two objects	Middle pos. : xxx Diameter: xxx Middle pos. : xxx Diameter: xxx
E,e	Detection of three objects	Middle pos. : xxx Diameter: xxx Middle pos. : xxx Diameter: xxx Middle pos. : xxx Diameter: xxx

Table 5.1: ASCII representation, output modes 1 ... 5

Example for xxx: 123 (12.3mm)

5.1.2 Binary representation via RS 232 (P and M12 interfaces)

Due to the fast output of measurement values, only data for single-object detection can be output in this output mode. The measurement values cannot be displayed on the screen (see chapter 7.2.2).

5.2 Edge measurement and height verification

With this measurement, the sensor expects only one edge within the measurement field. If more or fewer edges are detected by the system, depending on the configuration (see chapter 6.4), this leads to an error message.

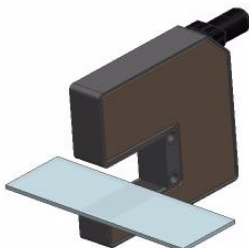

Figure 5.3: Edge measurement and height verification

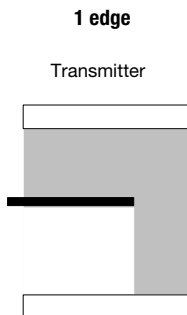

Figure 5.4: Edge measurement - Detection of 1 edge

Various configurations are possible with this measurement (see chapter 6.4). The following only applies to devices with an analog interface:

1. Linear edge measurement over the entire measuring range (s. point 8)
2. Teach-in edge measurement with 5V-output at teaching point

5.3 Width measurement

To measure the width of strip material, two GS 754B CCD forked photoelectric sensors can be used mutually opposed from one another.

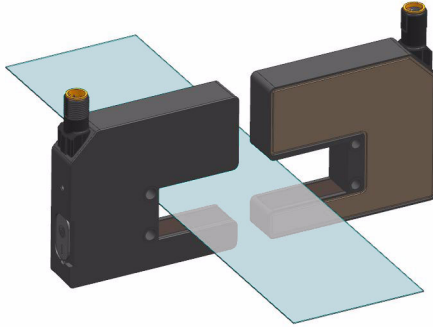

Figure 5.5: Width measurement

Each forked photoelectric sensor relays an edge position which can be extrapolated to the total width when the distance of the sensors vis-à-vis one another is known in the control. In conjunction with this, time synchronization of the measurement data is ensured via PIN 2 as a trigger input. If the control generates a LOW -> HIGH signal change at the trigger inputs, then both forked photoelectric sensors simultaneously each start an output cycle.

6 Device configuration

6.1 General information

To configure the GS 754B forked photoelectric sensor, you require a PC with an RS 232 interface and a terminal program with the following setting. For this, use the corresponding KB-ODS 96-1500 cable (part no. 50082007).

6.2 Terminal program

Any terminal or modem program that can access the serial interface(s) of your PC can be used for the configuration.

Under Microsoft® Windows® 95/98/NT/2000, you can use the HyperTerminal, for example.

6.2.1 Basic configuration of the terminal program (interface P)

Transmission rate	9600bit/s
Data bits	8
Parity	None
Stop bits	1
Protocol	None

Table 6.1: Basic configuration of the terminal program (interface P)

6.3 Configuration of the measurement, analysis and output procedures over interface P

The appropriate configuration is activated by entering ASCII characters. Letters may be entered in either capital or lowercase form.

6.3.1 Configuration table for GS 754B

ASCII commands			Available for interface
Output mode	Object type		
	"!" - perforated objects "?" - homogeneous objects	"%" - partially transparent, translucent objects	
1	output cycle approx. 3000 ms	output cycle approx. 700 ms	serial and analog
2	output cycle approx. 1000 ms	output cycle approx. 250 ms	serial and analog
3	output cycle approx. 500 ms	output cycle approx. 130 ms	serial and analog
4	output cycle approx. 250 ms	output cycle approx. 70 ms	serial and analog
5	output cycle approx. 100 ms	output cycle approx. 35 ms	serial and analog
6	reserved	reserved	
7 (default)	output cycle approx. 12 ms	output cycle approx. 3 ms	serial and analog
Averaging			
M,m	averaging across the specified output cycle period		serial and analog
A,a	output of individual measurement value (default)		serial and analog
Object number			
Q,q	single-object measurement (default)		serial (only modes 1-5)
W,w	measurement of two objects		serial (only modes 1-5)
E,e	measurement of three objects		serial (only modes 1-5)
Evaluation process			
=	diameter detection		serial and analog
-	edge detection (default)		serial and analog
Object type			
!	perforated objects		serial and analog
?	homogeneous objects (default)		serial and analog
%	semi-transparent, translucent objects		serial and analog
Reset			
R,r	reset with config. switching output (7,a,-,o,?) reset with config. teach input (7,a,-,t,?)		serial and analog

Edge assignment for analog output (single-object measurement)		
D,d	object diameter	analog
\$	edge, middle	analog
(inner edge (default)	analog
)	outer edge	analog
Function PIN 2		
T,t	teach input function	analog
O,o	switching output function	serial and analog
S, s	synchronization / trigger input function	serial and analog
L, l	activation input function (LED transmitter ON)	serial and analog
Switching function PIN 2 ¹⁾		
<	standard function (default) (chapter 6.4.6)	serial and analog
>	standard function, inverted (chapter 6.4.6)	serial and analog
*	photoelectric sensor function, dark switching (presence monitoring)	serial and analog
#	photoelectric sensor function, light switching (presence monitoring)	serial and analog
Switching level PIN 2		
P,p	PNP switching output (default)	serial and analog
N,n	NPN switching output	serial and analog
G,g	push-pull switching output	serial and analog

1) relative to the PNP switching level; refer to the following note.

Table 6.2: Parameterizing commands GS 754B

By entering the ASCII character "R", the state on delivery is restored. "R", however, has no effect on the configuration of the switching function and the switching level.



Notice

The descriptions of the PIN 2 switching functions (chapter 6.4.3 et seq.) always relate to the PNP switching level.

If the PIN 2 switching level is configured to NPN, all levels must be inverted.

6.4 Special configurations

6.4.1 Edge measurement for perforated objects

With this function, net-like objects, e.g. fabric, can be detected.

Here, the first edge of the object is output as the measurement value. All other edges are suppressed. In this configuration the number of edges is not checked. Error messages are not output.

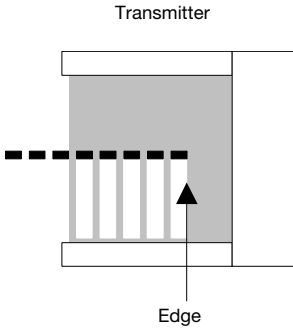

Figure 6.1: Edge measurement for perforated objects

Required ASCII commands:

Object number	
Q,q	single-object measurement (default)
Evaluation process	
-	edge detection (default)
Object type	
!	perforated objects

6.4.2 Changeover of the edge assignment for single-object measurement

Only one piece of edge information can be output via the analog interface. With single-object measurement, the sensor sees two edges. Using these edges, information such as object diameter and object middle can be calculated. These edge assignments can be configured.

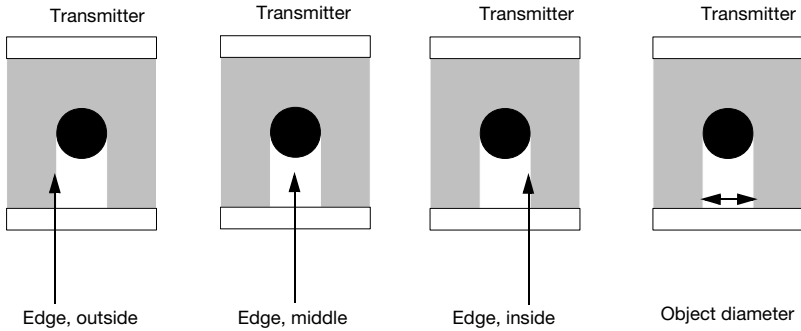

Figure 6.2: Changeover of the edge assignment for single-object measurement

ASCII commands for changing over the edge assignment:

Edge assignment for analog output (single-object measurement)	
D,d	object diameter
\$	edge, middle
(edge, inside (default)
)	edge, outside

6.4.3 PIN 2 as a teach input

Connection PIN 2 of devices with analog output can be configured as a warning output or as a teach input. If PIN 2 has been configured as a teach input, edge adjustment is possible here at 5V. In this way, any given point of the measurement field can be assigned the output value 5V.

6.4.3.1 Teach-in in the middle of the measurement field

The measurement value is output linearized. As a result, the entire measurement field is available for the measurement.

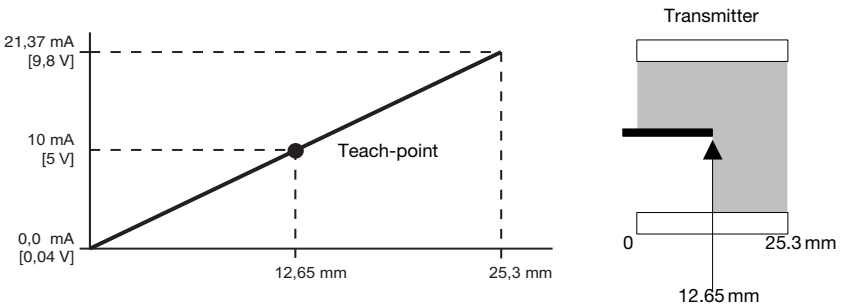

Figure 6.3: Teach-in (edge in the middle of the measurement field)

6.4.3.2 Teach-in at the end of the measurement field

The measurement value is output linearized. The measurement field range is restricted. A change in measurement value no longer occurs at the beginning of the measurement field.

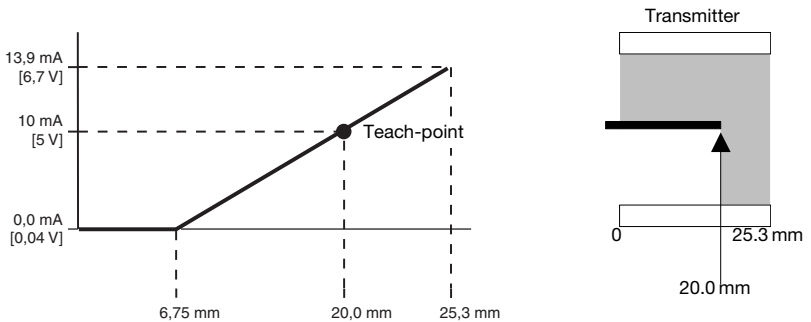

Figure 6.4: Teach-in (edge at the end of the measurement field)

6.4.3.3 Teach-in at the start of the measurement field

The measurement value is output linearized. The measurement field range is restricted. A change in measurement value no longer occurs at the end of the measurement field.

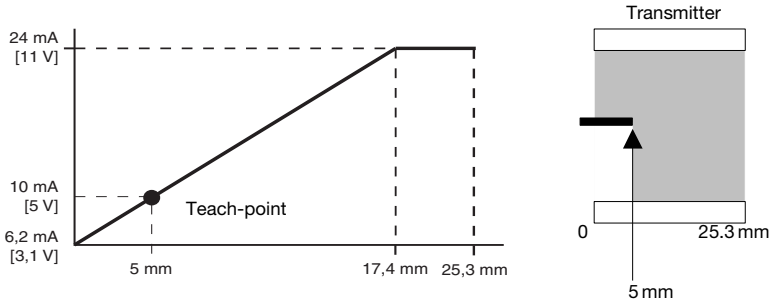

Figure 6.5: Teach-in (edge at start of the measurement field)

6.4.4 PIN 2 as a synchronization / trigger input

If PIN 2 is configured as a trigger input, the GS 745B CCD forked photoelectric sensor remains inactive as long as there is a LOW signal at PIN 2.

If the external signal changes from LOW to HIGH, the forked photoelectric sensor then performs exactly one measurement and outputs the configured measurement data.

The duration of this measurement varies depending on the set measure mode. The average value of the individual measurements is calculated within the set time ($n \cdot 12\text{ms}$).

6.4.5 PIN 2 as an activation input

If PIN 2 is configured as an activation input, the GS 745B CCD forked photoelectric sensor remains inactive as long as there is a LOW signal at PIN 2.

If there is a HIGH signal at PIN 2, the forked photoelectric sensor is activated and repeatedly performs measurements as long as the HIGH signal remains at PIN 2.

The measurement data are output at the interfaces depending on the measure mode set.

6.4.6 PIN 2 as a switching output

When PIN 2 is configured as a switching output, various logical functions can be assigned to this switching output. A distinction is made between standard and photoelectric sensor functions/presence monitoring.

Configuration	Function	Switching output pin 2		
		Object partially in measurement field	Object completely in measurement field	Object not in measurement field
<	standard	high	low	high
>	standard inverted	low	high	low
*	dark switching	high	high	low
#	light switching	low	low	high

6.4.6.1 Standard function

The number of object edges is monitored.

Example of diameter detection:

In this setting, the sensor expects two object edges. If more or fewer object edges are detected, an error message is output.

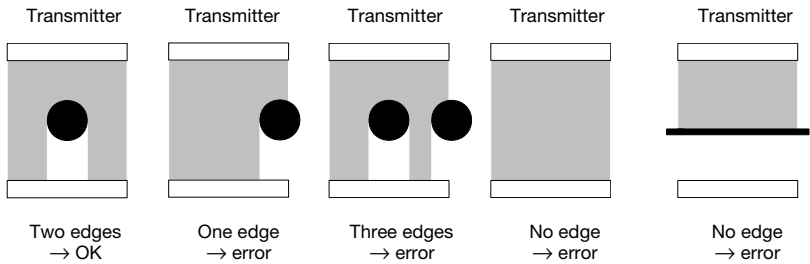

Figure 6.6: Example of diameter detection

Example of edge detection:

In this setting, the sensor expects only one object edge. If more or fewer object edges are detected, an error message is output.

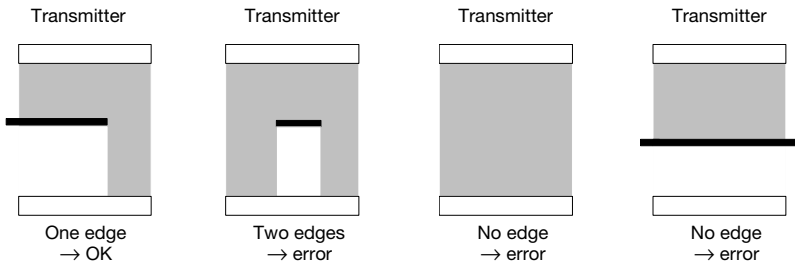

Figure 6.7: Example of edge detection

6.4.6.2 Standard function, inverted

The number of object edges is monitored and output inverted.

6.4.6.3 Photoelectric sensor function, dark switching

When configured for the photoelectric sensor function, the number of edges is not monitored. The entire measuring range is analyzed as a throughbeam photoelectric sensor. The switching output functions on a dark-switching basis.

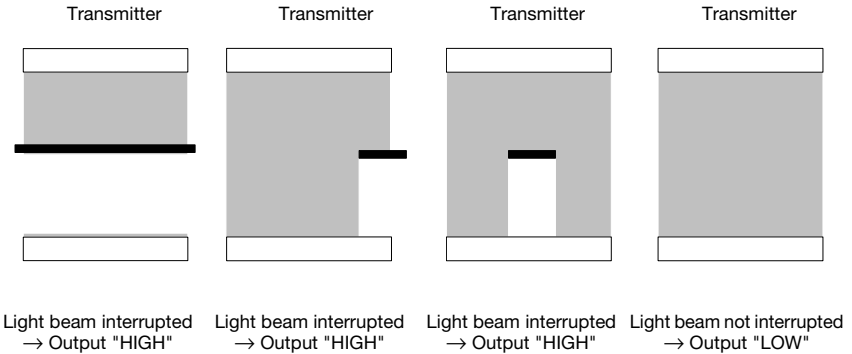

Figure 6.8: Photoelectric sensor function, dark switching

6.4.6.4 Photoelectric sensor function, light switching

With photoelectric sensor level, the entire measurement range is analyzed as a throughbeam photoelectric sensor. The switching output functions on a light-switching basis.

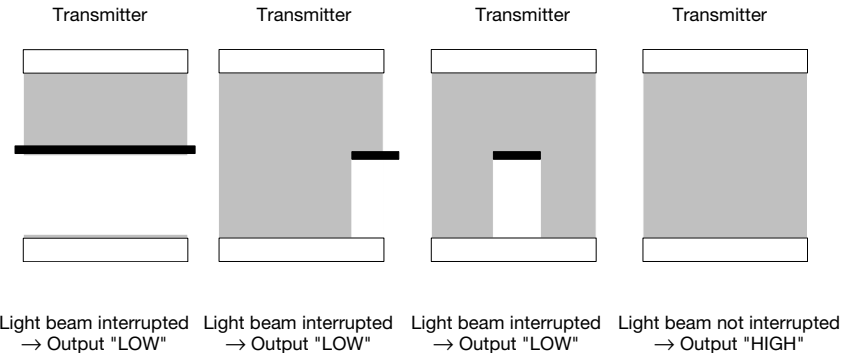

Figure 6.9: Photoelectric sensor function, light switching

7 Measurement range and resolution

The detection range of the GS 754B forked photoelectric sensor is max. 28.6mm (2048 • 14µm).

The maximum measurement range is 25.3mm.

Measurement values of the serial and analog interfaces are linearized.

The sensor makes the measurement values available in the following resolutions, depending on the output mode chosen:

Resolution:

	Output modes 1 ... 5	Output mode 7 (default)
Serial interface	0.1 mm (ASCII)	0.014 mm (binary)
Analog interface	0.1 mm (current/voltage)	0.014 mm (current/voltage)

7.1 Analog measurement value output (interface M12)

The analog current and voltage values are available only at the M12 interface. The data formats which are output differ depending on the type and configuration used. In output modes 1...5 and in output mode 7, the resolution/measurement resolution changes as follows.

	Output modes 1 ... 5	Output mode 7 (default)
Analog current	0.063 mA / 0.1 mm	11.72µA / 14 µm
Analog voltage	0.0316 V / 0.1 mm	5.37 mV / 14 µm

Table 7.1: Data formats for analog interface M12

Output modes 1 ... 5:

In output modes 1 ... 5, the measurement values are scaled. These measurement values are adapted to the standard 4 ... 20mA (2 ... 10V) interface via the internal microcontroller. The resulting measurement field for output modes 1 ... 5 is 25.3 mm (1807 * 14 µm).

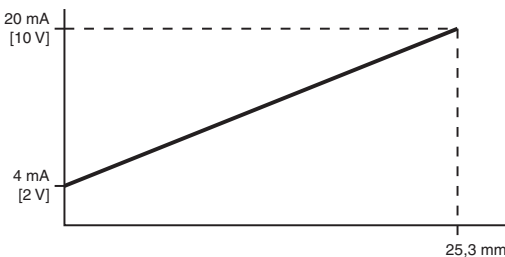

Figure 7.1: Linearity in output modes 1 ... 5

Output mode 7 (default):

In output mode 7, the measurement values are not scaled. Each measurement value is output directly. The resulting measurement field for output mode 7 is 25.3mm (1807 * 14µm) with an output current of 0 ... 21.37 mA (0.04 ... 9.8V).

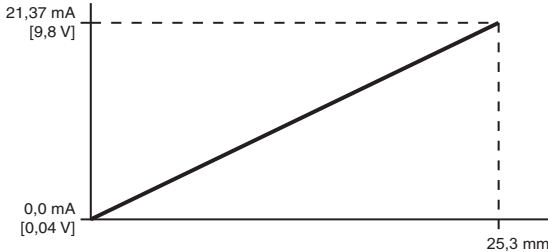

Figure 7.2: Linearity in output mode 7

7.2 Digital measurement value output (P and M 12 interfaces)

The measurement value output is dependent on the type of sensor used and the configuration set.

There are a number of different output modes available.

These are divided into two primary output variants:

1. Output modes 1, 2, 3, 4, 5:
the measurement value output is performed at 0.3Hz, 1 Hz, 2Hz, 4Hz or 10Hz. The measurement values are linearized by the sensor and converted to mm values. Conversion of the pixel data is no longer necessary. The sensor transmits the measurement values to interfaces P and M12. The digital information is, in this case, transmitted in ASCII format and can be read using the monitor program. The resolution is 0.1 mm.
2. Output mode 7:
the measurement value output is performed at 80Hz. The sensor transmits the measurement values to interfaces P and M12. In this case, digital information is transmitted in binary format and can be read with the monitor program. The resolution is 0.014 mm.

The various output formats are explained on the following pages using examples.

7.2.1 ASCII format for P and M12 interfaces

Readable ASCII data are only output via the digital interfaces in output modes 1, 2, 3, 4, 5. The resolution is 0.1 mm.

ASCII commands		Measurement value output in ASCII format
=, q, 5	Diameter detection	Middlepos. : xxx Diameter: xxx
-, q, 5	Edge detection	Edge-Pos. : xxx

Table 7.2: ASCII format for P and M12 interfaces

Example of diameter detection:

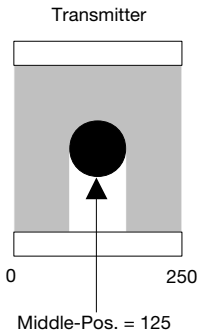

Figure 7.3: Ex. diameter detection (ASCII format)

Middle-Pos.: 125 (equivalent to 12.5 mm)
 Diameter: 020 (equivalent to 2.0 mm)

The middle of the object is located at CCD position 12.5mm.
 The object diameter is 2.0mm.

Example of edge detection:

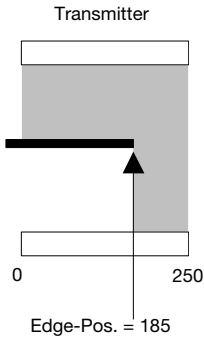

Figure 7.4: Ex. edge detection (ASCII format)

Edge-Pos.: 185 (equivalent to 18.5mm)

The edge of the object is located at CCD position 18.5mm.

7.2.2 Binary format for the P and M12 interfaces

Binary data is only output via the digital interfaces in output mode 7. This binary data cannot be displayed by the terminal program.

The resolution is 0.014mm.

ASCII commands	
=, q, 7	Diameter detection
-, q, 7	Edge detection

Table 7.3: Binary format for the P and M12 interfaces

Example of diameter detection:

Measurement value output in binary format								
Data						Byte designator		
D ₅	D ₄	D ₃	D ₂	D ₁	D ₀	P ₁	P ₀	
Middle-Pos.			(low byte)			0	0	byte 0
Middle-Pos.			(high byte)			0	1	byte 1
Diameter			(low byte)			1	0	byte 2
Diameter			(high byte)			1	1	byte 3

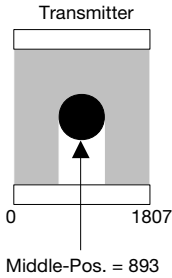

Figure 7.5: Ex. diameter detection (binary format)

The middle of the object is located at CCD pixel 893.

The diameter of the object is 143 pixels.

Measurement value output in binary format								
Data						Byte designator		
D ₅	D ₄	D ₃	D ₂	D ₁	D ₀	P ₁	P ₀	
1	1	1	1	0	1	0	0	byte 0
0	0	1	1	0	1	0	1	byte 1
0	0	1	1	1	1	1	0	byte 2
0	0	0	0	1	0	1	1	byte 3

001101111101
value: 893
(893 x 0.014mm = 12.5mm)

000010001111
value: 143
(143 x 0.014mm = 2.0mm)

Example of edge detection:

Measurement value output in binary format								
Data						Byte designator		
D ₅	D ₄	D ₃	D ₂	D ₁	D ₀	P ₁	P ₀	
Edge-Pos.			(low byte)			0	0	byte 0
Edge-Pos.			(high byte)			0	1	byte 1

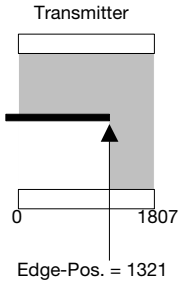

Figure 7.6: Ex. edge detection (binary format)

The edge of the object is located at CCD pixel 1321.

Measurement value output in binary format								
Data						Byte designator		
D ₅	D ₄	D ₃	D ₂	D ₁	D ₀	P ₁	P ₀	
1	0	1	0	0	1	0	0	byte 0
0	1	0	1	0	0	0	1	byte 1

010100101001
 value: 1321
 (1321 x 0.014mm = 18.5mm)

8 Error messages (P and M12 interfaces)

Errors vary depending on the configured measurement, analysis and output variants. The errors are output at interfaces P and M12.

		Fewer edges than specified	More edges than specified	Light path fully blocked
Serial output	Modes 1 ... 5	000	555	999
	Mode 7	0	2047	0
Analog current	Modes 1 ... 5	3.5mA	>20mA	>20mA
	Mode 7	0mA		
Analog voltage	Modes 1 ... 5	1.75V	>10V	>10V
	Mode 7	0V		

9 Service and support

24-hour on-call service at: +49 (0) 7021 573-0

Service hotline: +49 (0) 7021 573-217

Monday to Thursday, 8.00 a.m. to 5.00 p.m. (UTC+1)

Friday, 8.00 a.m. to 4.00 p.m. (UTC +1)

E-mail: service.detect@leuze.de

Return address for repairs:

Servicecenter Leuze electronic GmbH + Co. KG

In der Braike 1

D-73277 Owen

Germany

10 Specifications

10.1 Optical data

Mouth width	GS 754B/...-27...: 27 mm GS 754B/...-98...: 98 mm
Mouth depth	42 mm
Measurement range	25 mm
Resolution ¹⁾	a: 0.1 mm (modes 1 ... 5) b: 0.014 mm (mode 7, default)
Reproducibility	± 0.03 mm
Linearity	± 0.36 mm
Minimal object diameter	0.5 mm
Object position	any ²⁾
Light source	LED (modulated light)
Wavelength	850 nm

1) System resolution, i.e. smallest practical value for the last position of the display.

2) Objects < 1 mm should be scanned in front of the receiver.
Extraneous light sources must not beam into the receiver from the front.

10.2 Timing

Response time	min. 12 ms
Output cycle	0.012 ... 3.00 s
Delay before start-up	≤ 300 ms

10.3 Electrical data

Operating voltage U_B ¹⁾	with RS 232/RS 422: 10 ... 30VDC (incl. residual ripple) with analog output: 18 ... 30VDC (incl. residual ripple)
Residual ripple	≤ 15 % of U_B
Open-circuit current	≤ 60 mA

1) Protective extra-low voltage (VDE 0100/T 410).
For UL applications: only for use in class 2 circuits according to NEC.

Electrical connection

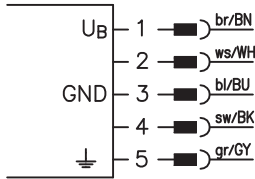

Functional earth must be wired.

Device models	PIN 1	PIN 2	PIN 3	PIN 4	PIN 5
RS 232	10...30VDC	I/O	GND	TxD	FE - functional earth
RS 422	10...30VDC	Tx-	GND	Tx+	FE - functional earth
Analog voltage	18...30VDC	I/O	GND	analog	FE - functional earth
Analog current	18...30VDC	I/O	GND	analog	FE - functional earth

10.4 Output signals

Level active/not active	$\geq 8V/\leq 2V$ or not connected
Activation/disable delay	≤ 1 ms
Input resistance	approx. $6k\Omega$
Switching output current	pin 2: max. 100mA
Analog output current	(0)4 ... 20mA (depending on output mode), $R_L \leq 500\Omega$
Analog output voltage	(0)2 ... 10V (depending on output mode), $R_L \geq 2k\Omega$
Serial interface	RS 232/RS 422
Teach input	pin 2 reversible
Switching output	pin 2 reversible

10.5 Mechanical data

Housing	diecast zinc
Weight	GS 754B/...-27...: 270g GS 754B/...-98...: 290g
Optics cover	plastic ¹⁾
Connection type	M12 connector, metal, 5-pin

1) Only fiber-free cloths may be used to clean the lens covers.
Tips and hard objects damage the lens.

10.6 Environmental data

Ambient temp. (operation/storage)	-20°C ... +50°C/-30°C ... +60°C
Protective circuit ¹⁾	1, 2, 3
VDE safety class	III
Protection class	IP 67
Light source	exempt group (in acc. with EN 62471)
Standards applied	IEC 60947-5-2
Certifications	UL 508, C22.2 No.14-13 ^{2) 3)}

1) 1=transient protection, 2=polarity reversal protection, 3=short circuit protection for all output.

2) Protective extra-low voltage (VDE 0100/T 410).

For UL applications: only for use in class 2 circuits according to NEC.

3) These proximity switches shall be used with UL Listed cable assemblies rated 30V, 0.2A min, in the field installation, or equivalent (categories: CYJV/CYJV7 or PVVA/PVVA7).

11 Order guide and accessories

11.1 Order guide

Selection table		GS 754B/D24-27-S12 Part no. 50115807	GS 754B/D3-27-S12 Part no. 50115806	GS 754B/V4-27-S12 Part no. 50115809	GS 754B/C4-27-S12 Part no. 50115803	GS 754B/D24-98-S12 Part no. 50119710	GS 754B/D3-98-S12 Part no. 50119711	GS 754B/V4-98-S12 Part no. 50117818	GS 754B/C4-98-S12 Part no. 50119712
Order code →									
Equipment ↓									
Mouth width	27 mm	●	●	●	●				
	98 mm					●	●	●	●
Output variants	RS 232	●				●			
	RS 422		●				●		
	Analog voltage			●				●	
	Analog current				●				●
Pin 2, configurable	I/O	●		●	●	●		●	●

11.2 Accessories

11.2.1 Connection cables

Part no.	Type designation	Description
50114692	KB DN/CAN-2000 BA	Connection cable, M12 socket axial, 5 pin, A-coded; length 2000 mm; open cable end; PUR; shielded
50114696	KB DN/CAN-5000 BA	Connection cable, M12 socket axial, 5 pin, A-coded; length 5000 mm; open cable end; PUR; shielded
50114699	KB DN/CAN-10000 BA	Connection cable, M12 socket axial, 5 pin, A-coded; length 10000 mm; open cable end; PUR; shielded

11.2.2 Configuration cable

Part no.	Type designation	Description
50082007	KB-ODS 96-1500	Connection cable, Sub-D socket, 9-pin; length 1500 mm; configuration connector GS 754B

12 Declaration of conformity

The GS 754B measuring CCD forked photoelectric sensors have been developed and manufactured in accordance with the applicable European standards and directives.

**Notice**

A corresponding Declaration of Conformity can be requested from the manufacturer.

The manufacturer of the GS 754B CCD forked photoelectric sensors, Leuze electronic GmbH + Co. KG in D-73277 Owen, possesses a certified quality assurance system in accordance with ISO 9001.

