



- Modular versions suitable for different type of installations, DIN rail, screw fixing or switchboard, also suitable for rear mounting plate fixing
- Minimum and maximum voltage monitoring relays for single and three-phase systems, with or without neutral
- Voltage asymmetry, phase sequence and phase loss control relays
- Multifunction voltage and frequency monitoring relays with NFC technology and APP
- Frequency monitoring relays
- Minimum and maximum current monitoring relays
- Interface protection system units compliant with standards CEI 0-21, CEI 0-16, DEWA DRRG, ENA G59-3/G99, VDE-AR-N 4105, VDE V 0126-1-1, SEC (Saudi Electricity Company).

	SEC. - PAGE
Voltage monitoring relays	
For three-phase systems, without neutral	19 - 4
For three-phase systems, with or without neutral	19 - 6
For single-phase systems	19 - 7
Multifunction voltage and frequency monitoring relays, programmable via NFC technology and APP	19 - 8
Frequency monitoring relays	19 - 9
Current monitoring relays	
For single-phase systems	19 - 9
For single and three-phase systems	19 - 10
Pump protection relays	19 - 11
Interface protection system units	19 - 12
Accessories	19 - 16
Dimensions	19 - 17
Wiring diagrams	19 - 18
Technical characteristics	19 - 22



Pages 19-4 to 7

VOLTAGE MONITORING RELAYS

- For three-phase systems with or without neutral and single-phase systems
- Minimum and maximum AC voltage
- Phase loss and incorrect phase sequence
- Asymmetry
- Minimum and maximum frequency.



Page 19-8

MULTIFUNCTION VOLTAGE AND FREQUENCY MONITORING RELAYS

- Voltage and frequency monitoring relays for three-phase systems with or without neutral
- Programmable via NFC technology and APP
- Minimum and maximum AC voltage
- Phase loss, neutral loss and incorrect phase sequence
- Asymmetry
- Minimum and maximum frequency.



Page 19-8

FREQUENCY MONITORING RELAYS

- For single and three-phase systems
- Minimum frequency
- Maximum frequency.



Pages 19-9 and 10

CURRENT MONITORING RELAYS

- For single and three-phase systems
- Maximum AC/DC current
- Minimum or maximum AC/DC current
- Minimum and maximum AC/DC current.



Page 19-11

PUMP PROTECTION RELAYS

- For single and three-phase systems
- Minimum $\cos\phi$ for dry running protection
- Maximum AC current
- Phase loss and incorrect phase sequence.



Page 19-12

INTERFACE PROTECTION SYSTEM UNITS

- Compliant with Italian standard CEI 0-21, for low voltage
- Compliant with Italian standard CEI 0-16, for medium voltage
- Compliant with standard SHAMS DUBAI - DRRG (DEWA)
- Compliant with technical guide SEC (Saudi Electricity Company)
- Compliant with technical guide ENA G59-3/G99
- Compliant with technical guide VDE-AR-N 4105
- Compliant with technical guide VDE V 0126-1-1.

Voltage monitoring relays for three-phase systems without neutral



	PMV10	PMV20	PMV30	PMV40	PMV50	PMV70
Modular version	●(1U)	●(2U)	●(2U)	●(2U)	●(2U)	●(2U)
Minimum AC voltage			●		●	●
Maximum AC voltage					●	●
Phase loss	●	●	●	●	●	●
Incorrect phase sequence	●	●	●	●	●	●
Asymmetry				●		●
Page		19-4			19-5	19-5

Voltage monitoring relays for three-phase systems with or without neutral



	PMV50N	PMV70N	PMV80N	PMV95N
Modular version	●(3U)	●(3U)	●(3U)	●(2U)
Minimum AC voltage	●	●	●	●
Maximum AC voltage	●	●	●	●
Phase loss	●	●	●	●
Neutral loss	●	●	●	●
Incorrect phase sequence	●	●	●	●
Asymmetry		●		●
Minimum frequency			●	●
Maximum frequency			●	●
Programmable via NFC technology and APP				●
Page	19-6	19-6	19-7	19-8

Voltage monitoring relay for single-phase systems



	PMV55
Modular version	●(2U)
Minimum AC voltage	●
Maximum AC voltage	●
Page	19-7

Frequency monitoring relays for single-phase and three-phase systems



	PMF20
Modular version	●(2U)
Minimum frequency	●
Maximum frequency	●
Page	19-9

Current monitoring relays for single and three-phase systems



	PMA20	PMA30	PMA40
Modular version	●(2U)	●(2U)	●(3U)
Maximum AC/DC current	●		
Minimum or maximum AC/DC current		●	
Minimum and maximum AC/DC current			●
Page	19-9		19-10

Pump protection relay for single and three-phase systems



	PMA50
Modular version	●(3U)
Minimum cosφ for dry running pump protection	●
Maximum AC current	●
Phase loss	●
Incorrect phase sequence	●
Page	19-11

Interface protection system units



	PMVF20	PMVF30	PMVF51	PMVF60	PMVF70	PMVF80
CEI 0-21	●		●			
CEI 0-16		●				
DEWA DRRG				●		
SEC (Saudi Electricity Company)				●		
ENA G59-3/G99					●	
VDE-AR-N 4105						●
VDE V 0126-1-1						●
Page	19-12	19-14	19-13	19-15	19-15	19-15

For three-phase systems, without neutral



PMV10A440

PMV20...

Order code	Rated voltage to control Ue (phase-to-phase) [V] 50/60Hz	Qty per pkg n°	Wt [kg]
------------	---	-------------------	------------

Three-phase system, without neutral. Phase loss and incorrect phase sequence. Instantaneous trip. 1 module housing.

PMV10A440	208...480VAC	1	0.050
2 modules housing.			
PMV20A240	100...240VAC	1	0.120
PMV20A575	208...575VAC	1	0.120
PMV20A600	380...600VAC	1	0.120



PMV30...

Order code	Rated voltage to control Ue (phase-to-phase) [V] 50/60Hz	Qty per pkg n°	Wt [kg]
------------	---	-------------------	------------

Three-phase system, without neutral. Minimum AC voltage. Delayed trip. Phase loss and incorrect phase sequence. Instantaneous trip.

PMV30A240	208...240VAC	1	0.130
PMV30A575	380...575VAC	1	0.130
PMV30A600	600VAC	1	0.130



PMV40...

Order code	Rated voltage to control Ue (phase-to-phase) [V] 50/60Hz	Qty per pkg n°	Wt [kg]
------------	---	-------------------	------------

Three-phase system, without neutral. Asymmetry. Delayed trip. Phase loss and incorrect phase sequence. Instantaneous trip.

PMV40A240	208...240VAC	1	0.130
PMV40A575	380...575VAC	1	0.130
PMV40A600	600VAC	1	0.130

General characteristics

- Voltage monitoring relay, self powered, for phase loss and incorrect phase sequence
- Phase loss detection if one of the voltages is <70% rated value
- Phase loss tripping time: 60ms
- 1 relay output with 1 changeover contact (SPDT)
- Modular DIN 43880 housing: 1 module for PMV10; 2 modules for PMV20
- Mounting on 35mm DIN rail (IEC/EN/BS 60715) or screw fixing via pull out tabs
- IEC degree of protection: IP40 on front (only when placed in IP40 enclosure or control board); IP20 at terminals.

Certifications and compliance

Certifications obtained: UL Listed, for USA and Canada (cULus - File E93601) as Auxiliary Devices; EAC. Compliant with standards: IEC/EN/BS 60255-27, IEC/EN/BS 61000-6-2, IEC/EN/BS 61000-6-3, UL 508, CSA C22.2 n° 14.

General characteristics

- Voltage monitoring relay, self powered, for minimum voltage, phase loss and incorrect phase sequence
- Configurable rated voltage (Ue):
 - PMV30A240: 208-220-230-240VAC
 - PMV30A575: 380-400-415-440-460-480-525-575VAC
- Excellent tripping accuracy
- TRMS measurements (True Root Mean Square)
- Control of phase-to-phase voltages
- Phase loss detection if one of the voltages is <70% rated value
- Phase loss tripping time: 60ms
- 1 relay output with 1 changeover contact (SPDT)
- Modular DIN 43880 housing, 2 modules
- Mounting on 35mm DIN rail (IEC/EN/BS 60715) or screw fixing via pull out tabs
- IEC degree of protection: IP40 on front (only when placed in IP40 enclosure or control board); IP20 at terminals.

ADJUSTMENTS

- "V min" Minimum voltage tripping threshold
80...95% Ue
- "Delay" Tripping time 0.1...20s
- "Reset delay" Resetting time 0.1...20s.

Certifications and compliance

Certifications obtained: UL Listed, for USA and Canada (cULus - File E93601), as Auxiliary Devices; EAC. Compliant with standards: IEC/EN/BS 60255-27, IEC/EN/BS 61000-6-2, IEC/EN/BS 61000-6-3, UL 508, CSA C22.2 n° 14.

General characteristics

- Voltage monitoring relay, self powered, for asymmetry, phase loss and incorrect phase sequence
- Excellent tripping accuracy
- TRMS measurements (True Root Mean Square)
- Control of phase-to-phase voltages
- Phase loss detection if one of the voltages is <70% rated value
- Phase loss tripping time: 60ms
- 1 relay output with 1 changeover contact (SPDT)
- Modular DIN 43880 housing, 2 modules
- Mounting on 35mm DIN rail (IEC/EN/BS 60715) or screw fixing via pull out tabs
- IEC degree of protection: IP40 on front (only when placed in IP40 enclosure or control board); IP20 at terminals.

ADJUSTMENTS

- "Asymmetry" High voltage asymmetry tripping threshold
5...15% Ue
- "Delay" Tripping time 0.1...20s
- "Reset delay" Resetting time 0.1...20s.

Certifications and compliance

Certifications obtained: UL Listed, for USA and Canada (cULus - File E93601), as Auxiliary Devices; EAC. Compliant with standards: IEC/EN/BS 60255-27, IEC/EN/BS 61000-6-2, IEC/EN/BS 61000-6-3, UL 508, CSA C22.2 n° 14.

For three-phase systems, without neutral



PMV50...

Order code	Rated voltage to control Ue (phase-to-phase)	Qty per pkg	Wt
	[V] 50/60Hz	n°	[kg]
Three-phase system, without neutral. Minimum and maximum AC voltage. Delayed trip. Phase loss and incorrect phase sequence. Instantaneous trip.			
PMV50A240	208...240VAC	1	0.130
PMV50A575	380...575VAC	1	0.130
PMV50A600	600VAC	1	0.130

General characteristics

- Voltage monitoring relay, self powered, for minimum and maximum voltage, phase loss and incorrect phase sequence
- Configurable rated voltage (Ue):
 - PMV50A240: 208-220-230-240VAC
 - PMV50A575: 380-400-415-440-460-480-525-575VAC
- High tripping accuracy
- TRMS measurements (True Root Mean Square)
- Control of phase-to-phase voltages
- Phase loss detection if one of the voltages is <70% rated value
- Phase loss tripping time: 60ms
- 1 relay output with 1 changeover contact (SPDT)
- Modular DIN 43880 housing, 2 modules
- Mounting on 35mm DIN rail (IEC/EN/BS 60715) or screw fixing via pull out tabs
- IEC degree of protection: IP40 on front (only when placed in IP40 enclosure or control board); IP20 on terminals.

ADJUSTMENTS

- "V max" Maximum voltage tripping threshold
105...115% Ue
- "V min" Minimum voltage tripping threshold
80...95% Ue
- "Delay" for each Tripping time 0.1...20s
- "Reset delay" Resetting time 0.1...20s.

Certifications and compliance

Certifications obtained: UL Listed, for USA and Canada (cULus - File E93601) as Auxiliary Devices; EAC.
Compliant to standards: IEC/EN/BS 60255-27, IEC/EN/BS 61000-6-2, IEC/EN/BS 61000-6-3, UL 508, CSA C22.2 n° 14.



PMV70...

Order code	Rated voltage to control Ue (phase-to-phase)	Qty per pkg	Wt
	[V] 50/60Hz	n°	[kg]
Three-phase system, without neutral. Minimum and maximum AC voltage and asymmetry. Delayed trip. Phase loss and incorrect phase sequence. Instantaneous trip.			
PMV70A240	208...240VAC	1	0.130
PMV70A575	380...575VAC	1	0.130
PMV70A600	600VAC	1	0.130

General characteristics

- Voltage monitoring relay, self powered, for minimum and maximum voltage, phase loss, incorrect phase sequence and asymmetry
- Configurable rated voltage (Ue):
 - PMV70A240: 208-220-230-240VAC
 - PMV70A575: 380-400-415-440-460-480-525-575VAC
- Excellent tripping accuracy
- TRMS measurements (True Root Mean Square)
- Control of phase-to-phase voltages
- Phase loss detection if one of the voltages is <70% rated value
- Phase loss tripping time: 60ms
- 1 relay output with 1 changeover contact (SPDT)
- Modular DIN 43880 housing, 2 modules
- Mounting on 35mm DIN rail (IEC/EN/BS 60715) or screw fixing via pull out tabs
- IEC degree of protection: IP40 on front (only when placed in IP40 enclosure or control board); IP20 at terminals.

ADJUSTMENTS

- "V max" Maximum voltage tripping threshold
105...115% Ue
- "V min" Minimum voltage tripping threshold
80...95% Ue
- "Delay" for each Tripping delay 0.1...20s
- "Asymmetry" High voltage asymmetry tripping threshold
5...15% Ue.

Certifications and compliance

Certifications obtained: UL Listed, for USA and Canada (cULus - File E93601), as Auxiliary Devices; EAC.
Compliant with standards: IEC/EN/BS 60255-27, IEC/EN/BS 61000-6-2, IEC/EN/BS 61000-6-3, UL 508, CSA C22.2 n° 14.

For three-phase systems with or without neutral

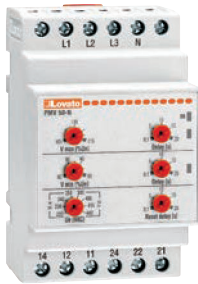

PMV50N...

Order code	Rated voltage to control U _e (phase-to-phase)	Qty per pkg	Wt
	[V] 50/60Hz	n°	[kg]
PMV50NA240	208...240VAC	1	0.200
PMV50NA440	380...440VAC	1	0.200
PMV50NA600	480...600VAC	1	0.200

Three-phase system, with or without neutral.
Minimum and maximum AC voltage. Delayed trip.
Phase loss, neutral loss and incorrect phase sequence.
Instantaneous trip.

General characteristics

- Voltage monitoring relay, self powered, for minimum and maximum voltage, phase loss, neutral loss and incorrect phase sequence
- 4 configurable rated voltages (U_e):
 - **PMV50NA240**: 208-220-230-240VAC (phase-to-phase) 120-127-132-138VAC (phase-to-neutral)
 - **PMV50NA440**: 380-400-415-440VAC (phase-to-phase) 220-230-240-254VAC (phase-to-neutral)
 - **PMV50NA600**: 480-525-575-600VAC (phase-to-phase) 277-303-332-347VAC (phase-to-neutral)
- Excellent tripping accuracy
- TRMS measurements (True Root Mean Square)
- Phase loss detection when one of the voltages is <70% rated voltage
- Phase or neutral loss tripping time: 60ms
- 2 relay outputs, each with 1 changeover contact (SPDT)
- Modular DIN 43880 housing, 3 modules
- Mounting on 35mm DIN rail (IEC/EN/BS 60715) or screw fixing via pull out tabs
- IEC degree of protection: IP40 on front (only when placed in IP40 enclosure or control board); IP20 at terminals.

ADJUSTMENTS

- "V max" Maximum voltage tripping threshold 105...115% U_e
- "V min" Minimum voltage tripping threshold 80...95% U_e
- "Delay" for each Tripping time 0.1...20s
- "Reset delay" Resetting time 0.1...20s.

Certifications and compliance

Certifications obtained: EAC.
Compliant with standards: IEC/EN/BS 60255-27, IEC/EN/BS 61000-6-2, IEC/EN/BS 61000-6-3.

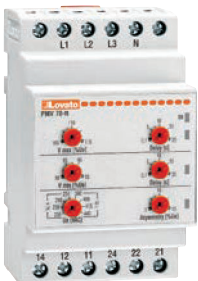

PMV70N...

Order code	Rated voltage to control U _e (phase-to-phase)	Qty per pkg	Wt
	[V] 50/60Hz	n°	[kg]
PMV70NA240	208...240VAC	1	0.200
PMV70NA440	380...440VAC	1	0.200
PMV70NA600	480...600VAC	1	0.200

Three-phase system, with or without neutral.
Minimum and maximum AC voltage and asymmetry.
Delayed trip.
Phase loss, neutral loss and incorrect phase sequence.
Instantaneous trip.

General characteristics

- Voltage monitoring relay, self powered, for minimum and maximum voltage, phase loss, neutral loss, incorrect phase sequence and asymmetry
- 4 configurable rated voltage (U_e):
 - **PMV70NA240**: 208-220-230-240VAC (phase-to-phase) 120-127-132-138VAC (phase-to-neutral)
 - **PMV70NA440**: 380-400-415-440VAC (phase-to-phase) 220-230-240-254VAC (phase-to-neutral)
 - **PMV70NA600**: 480-525-575-600VAC (phase-to-phase) 277-303-332-347VAC (phase-to-neutral)
- Excellent tripping accuracy
- TRMS measurements (True Root Mean Square)
- Phase loss detection when one of the voltages is <70% rated value
- Phase or neutral loss tripping time: 60ms
- 2 relay outputs, each with 1 changeover contact (SPDT)
- Modular DIN 43880 housing, 3 modules
- Mounting on 35mm DIN rail (IEC/EN/BS 60715) or screw fixing via pull out tabs
- IEC degree of protection: IP40 on front (only when placed in IP40 enclosure or control board); IP20 at terminals.

ADJUSTMENTS

- "V max" Maximum voltage tripping threshold 105...115% U_e
- "V min" Minimum voltage tripping threshold 80...95% U_e
- "Delay" for each Tripping time 0.1...20s
- "Asymmetry" High voltage asymmetry tripping threshold 5...15% U_e.

Certifications and compliance

Certifications obtained: EAC.
Compliant with standards: IEC/EN/BS 60255-27, IEC/EN/BS 61000-6-2, IEC/EN/BS 61000-6-3.

For three-phase systems, with or without neutral



PMV80N...

Order code	Rated voltage to control Ue (phase-to-phase)	Qty per pkg	Wt
	[V] 50/60Hz	n°	[kg]
Three-phase system, with or without neutral. Minimum and maximum AC voltage, minimum and maximum frequency. Delayed trip. Phase loss, neutral loss and incorrect phase sequence. Instantaneous trip.			
PMV80NA240	208...240VAC	1	0.200
PMV80NA440	380...440VAC	1	0.200
PMV80NA600	480...600VAC	1	0.200

General characteristics

- Voltage monitoring relay, self powered, for minimum and maximum voltage, minimum and maximum frequency, phase loss, neutral loss and incorrect phase sequence
- 4 configurable rated voltages (Ue):
 - PMV80NA240: 208-220-230-240VAC (phase-to-phase) 120-127-132-138VAC (phase-to-neutral)
 - PMV80NA440: 380-400-415-440VAC (phase-to-phase) 220-230-240-254VAC (phase-to-neutral)
 - PMV80NA600: 480-525-575-600VAC (phase-to-phase) 277-303-332-347VAC (phase-to-neutral)
- Excellent tripping accuracy
- TRMS measurements (True Root Mean Square)
- Phase loss detection if one of the voltages is <70% rated value
- Phase or neutral loss tripping time: 60ms
- 2 relay outputs, each with 1 changeover contact (SPDT)
- Modular DIN 43880, 3 modules
- Mounting on 35mm DIN rail (IEC/EN/BS 60715) or screw fixing via pull out tabs
- IEC degree of protection: IP40 on front (only when placed in IP40 enclosure or control board); IP20 at terminals.

ADJUSTMENTS

- "V max" Maximum voltage tripping threshold 105...115% Ue
- "V min" Minimum voltage tripping threshold 80...95% Ue
- "Hz min/max" Minimum/maximum frequency tripping threshold ±1...10% rated frequency
- "V delay" Tripping time 0.1...20s
- "Hz delay" Tripping time 0.1...5s.

Certifications and compliance

Certifications obtained: EAC.
Compliant with standards: IEC/EN/BS 60255-27, IEC/EN/BS 61000-6-2, IEC/EN/BS 61000-6-3.

For single-phase systems



PMV55...

Order code	Rated voltage to control Ue	Qty per pkg	Wt
	[V] 50/60Hz	n°	[kg]
Single-phase system. Minimum and maximum AC voltage. Delayed trip.			
PMV55A127	110...127VAC	1	0.125
PMV55A240	208...240VAC	1	0.125
PMV55A440	380...440VAC	1	0.125

General characteristics

- Voltage monitoring relay, self powered, for minimum and maximum voltage
- 4 configurable rated voltage (Ue):
 - PMV55A127: 110-115-120-127VAC
 - PMV55A240: 208-220-230-240VAC
 - PMV55A440: 380-400-415-440VAC
- Excellent tripping accuracy
- TRMS measurements (True Root Mean Square)
- 1 relay output with 1 changeover contact (SPDT)
- Modular DIN 43880 housing, 2 modules
- Mounting on 35mm DIN rail (IEC/EN/BS 60715) or screw fixing via pull out tabs
- IEC degree of protection: IP40 on front (only when placed in IP40 enclosure or control board); IP20 at terminals.

ADJUSTMENTS

- "V max" Maximum voltage tripping threshold 105...115% Ue
- "V min" Minimum voltage tripping threshold 80...95% Ue
- "Delay" for each Tripping time 0.1...20s
- "Reset delay" Resetting time 0.1...20s.

Certifications and compliance

Certifications obtained: UL Listed, for USA and Canada (cULus - File E93601), as Auxiliary Devices; EAC.
Compliant with standards: IEC/EN/BS 60255-27, IEC/EN/BS 61000-6-2, IEC/EN/BS 61000-6-3, UL 508, CSA C22.2 n° 14.

Multifunction voltage and frequency monitoring relays for three-phase systems with or without neutral, with NFC technology and APP



PMV95N...



The App can be downloaded from Google Play Store and App Store.



Order code	Rated voltage to control Ue (phase-to-phase)	Qty per pkg	Wt
	[V] 50/60Hz	n°	[kg]
Three-phase system, with or without neutral. Minimum and maximum AC voltage, minimum and maximum frequency and asymmetry. Delayed trip. Phase loss, neutral loss and phase sequence. Instantaneous trip. Programmable via smartphone or tablet with NFC technology and App.			
PMV95NA240NFC	208...240VAC	1	0.130
PMV95NA575NFC	380...575VAC	1	0.130

General characteristics

- Multifunction voltage and frequency monitoring relay, self powered, for minimum and maximum voltage, minimum and maximum frequency, phase loss, neutral loss, incorrect phase sequence and asymmetry.
- NFC connectivity for parameter setting with LOVATO NFC App, freely downloadable from Google Play Store and App Store
- Simple, fast and intuitive programming
- Very high accuracy and repeatability of the settings
- Possibility to save the program on smartphone or tablet to be copied on other PMV95N, even with device powered off
- Possibility to enable or disable individually the functions of interest
- Possibility to protect the settings with a password
- QR code for the direct connection to the website www.LovatoElectric.com for the download of the technical manual
- Excellent tripping accuracy
- TRMS measurements (True Root Mean Square)
- Phase loss detection if one of the voltages is <70% rated value
- 1 relay output with changeover contact (SPDT)
- Modular DIN 43880 housing, 2 modules
- Mounting on 35mm DIN rail (IEC/EN/BS 60715) or screw fixing via pull out tabs
- IEC degree of protection: IP40 on front (only when placed in IP40 enclosure or control board); IP20 at terminals.
- Adjustments: consult the technical manual on the website www.LovatoElectric.com.

8 protection functions in a single product, with possibility to enable or disable individually the functions of interest.

- maximum voltage
- minimum voltage
- maximum frequency
- minimum frequency
- asymmetry
- phase loss
- neutral loss
- incorrect phase sequence

Compact dimensions

Suitable for three-phase systems with or without neutral. It comes in a 2 DIN module housing

Excellent accuracy of settings with digital setting of time and tripping thresholds.

Repeatability of settings, with possibility to save the programming on the smartphone to be copied in fast way on other relays without risk of error.

Simple and intuitive programming thanks to the graphic interface of the LOVATO NFC App that shows on the display of the smartphone the functions and parameters without need to consult the technical manual.



Protection of settings with a password.

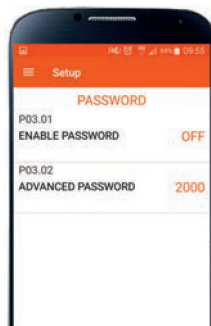

19 Monitoring relays

Frequency monitoring relays.
Current monitoring relays

Frequency monitoring relays for single and three-phase systems



PMF20...

Order code	Rated voltage Ue	Qty per pkg	Wt
	[V] 50/60Hz	n°	[kg]
Single and three-phase systems. Minimum and maximum frequency. Delayed trip. Automatic reset.			
PMF20A240	220...240VAC	1	0.125
PMF20A415	380...415VAC	1	0.125

General characteristics

- Frequency monitoring relay, self powered, for minimum and maximum control
- Rated frequency selection: 50 or 60Hz
- Tripping threshold for minimum and maximum frequency
- Excellent tripping accuracy
- 1 relay output, configurable, with 1 changeover contact (SPDT)
- Modular DIN 43880 housing, 2 modules
- Mounting on 35mm DIN rail (IEC/EN/BS 60715) or screw fixing via pull out tabs
- IEC degree of protection: IP40 on front (only when placed in IP40 enclosure or control board); IP20 at terminals.

ADJUSTMENTS

- "Hz max" Maximum frequency tripping threshold
101...110% rated frequency
- "Delay" Tripping time 0.1...20s
- "Hz min" Minimum frequency tripping threshold
90...99% rated frequency
- "Delay" Tripping time 0.1...20s
- "Reset delay" Resetting time 0.1...20s
- "Mode"
 - Minimum and maximum frequency with output relay normally energised
 - Maximum frequency with output relay normally energised
 - Minimum frequency with output relay normally energised
 - Maximum frequency with output relay normally de-energised.

Certifications and compliance

Certifications obtained: UL Listed, for USA and Canada (cULus - File E93601), as Auxiliary Devices; EAC. Compliant with standards: IEC/EN/BS 60255-27, IEC/EN/BS 61000-6-2, IEC/EN/BS 61000-6-3, UL 508, CSA C22.2 n° 14.

Current monitoring relay for single-phase systems



PMA20240

Order code	Rated current Ie	Auxiliary supply voltage	Qty per pkg	Wt
	[A]	[V]	n°	[kg]
Single-phase system. AC/DC maximum current control. Auxiliary AC/DC power supply. Automatic or manual reset.				
PMA20240	5 or 16A	24...240V AC/DC	1	0.121

General characteristics

- Current monitoring relay for AC/DC maximum current control
- AC/DC multivoltage auxiliary power supply
- Direct connection up to 16A max or by current transformer (CT)
- Excellent tripping accuracy
- TRMS current measurements (True Root Mean Square)
- Resetting and inhibition input
- 1 relay output with 1 changeover contact (SPDT)
- Modular DIN 43880 housing, 2 modules
- Mounting on 35mm DIN rail (IEC/EN/BS 60715) or screw fixing via pull out tabs
- IEC degree of protection: IP40 on front (only when placed in IP40 enclosure or control board); IP20 at terminals.

ADJUSTMENTS

- "Imax" Maximum current tripping threshold
5...100% Ie
- "Hysteresis" Maximum hysteresis threshold
1...50%
- "Trip delay" Tripping time 0.1...30s
- "Inhibition time" Inhibition delay for external input or at power up 1...60s
- "Aut. reset delay" Automatic resetting time 0.1...30s
- "Mode"
 - Rated current 5A or 16A
 - Relay output normally energised or de-energised
 - Tripping memory (latch) ON or OFF.

Certifications and compliance

Certifications obtained: UL Listed, for USA and Canada (cULus - File E93601), as Auxiliary Devices - Modular ampere monitoring relays; EAC. Compliant with standards: IEC/EN/BS 60255-27, IEC/EN/BS 61000-6-2, IEC/EN/BS 61000-6-3, UL 508, CSA C22.2 n° 14.

Current monitoring relays for single and three-phase systems



PMA30240

Order code	Rated current I _e	Auxiliary supply voltage	Qty per pkg	Wt
	[A]	[V]	n°	[kg]
Single and three-phase system. AC/DC minimum or maximum current control. Delayed trip. Auxiliary AC/DC power supply. Automatic or manual reset.				
PMA30240	5 or 16A	24...240V AC/DC	1	0.121

General characteristics

- Current monitoring relay for AC/DC minimum or maximum current control
- AC/DC multivoltage auxiliary power supply
- Automatic or manual reset.
- Direct connection up to 16A max or by current transformer (CT)
- Excellent tripping accuracy
- TRMS current measurements (True Root Mean Square)
- Resetting and inhibition input
- 1 relay output with 1 changeover contact (SPDT)
- Modular DIN 43880 housing, 2 modules
- Mounting on 35mm DIN rail (IEC/EN/BS 60715) or screw fixing via pull out tabs
- IEC degree of protection: IP40 on front (only when placed in IP40 enclosure or control board); IP20 at terminals.

ADJUSTMENTS

- "Set point" Minimum or maximum current tripping threshold 5...100% I_e
- "Hysteresis" Minimum or maximum hysteresis threshold 1...50%
- "Trip delay" Tripping time 0.1...30s
- "Inhibition time" Inhibition delay for external input or at power up 1...60s
- "I_e" Current scale selection: 5A or 16A
- "Mode"
 - Min or max function
 - Relay output normally energised or de-energised
 - Tripping memory (latch) ON or OFF.

Certifications and compliance

Certifications obtained: UL Listed, for USA and Canada (cULus - File E93601), as Auxiliary Devices - Modular ampere monitoring relays; EAC.
Compliant with standards: IEC/EN/BS 60255-27, IEC/EN/BS 61000-6-2, IEC/EN/BS 61000-6-3, UL 508, CSA C22.2 n° 14.



PMA40240

Order code	Rated current I _e	Auxiliary supply voltage	Qty per pkg	Wt
	[A]	[V]	n°	[kg]
Single and three-phase system. AC/DC minimum and maximum current control. Delayed trip. Auxiliary AC/DC power supply. Automatic or manual reset.				
PMA40240	0.02-0.05-0.25-1-5-16A	24...240V AC/DC	1	0.166

General characteristics

- Current monitoring relay for AC/DC minimum and maximum current control
- AC/DC multivoltage auxiliary power supply
- Direct connection up to 16A max or by current transformer (CT)
- Excellent tripping accuracy
- TRMS current measurements (True Root Mean Square)
- Automatic or manual resetting (manual resetting by power removal)
- 2 relay outputs (Min and Max), configurable, each with 1 changeover contact (SPDT)
- Modular DIN 43880 housing, 3 modules
- Mounting on 35mm DIN rail (IEC/EN/BS 60715) or screw fixing via pull out tabs
- IEC degree of protection: IP40 on front (only when placed in IP40 enclosure or control board); IP20 at terminals.

ADJUSTMENTS

- "I_{max}" Maximum current tripping threshold 5...100% I_e
- "I_{min}" Minimum current tripping threshold 5...100% I_e
- "Trip delay" Minimum and maximum current tripping time 0.1...30s
- "Inhibition time" Inhibition time at power up 1...60s
- "I_e" Current scale selection: 20mA, 50mA, 250mA, 1A, 5A or 16A
- "Mode"
 - Separate or common relay outputs
 - Relay output normally energised or de-energised
 - Tripping memory (latch) ON or OFF.

Certifications and compliance

Certifications obtained: UL Listed, for USA and Canada (cULus - File E93601), as Auxiliary Devices - Modular ampere monitoring relays; EAC.
Compliant with standards IEC/EN/BS 60255-27, IEC/EN/BS 61000-6-2, IEC/EN/BS 61000-6-3, UL 508, CSA C22.2 n° 14.

For single and three-phase systems



PMA50...

Order code	Rated current I_e	Auxiliary supply voltage	Qty per pkg	Wt
	[A]	[V]	n°	[kg]

Single and three-phase systems.
Maximum AC current and minimum $\cos\phi$. Delayed trip.
Phase loss and incorrect phase sequence. Instantaneous trip.
Auxiliary AC power supply.
Automatic or manual reset.

PMA50A240	5 or 16A	220...240VAC	1	0.251
PMA50A415		380...415VAC	1	0.251
PMA50A480		440...480VAC	1	0.251

General characteristics

- Pump protection relay against dry running
- Auxiliary AC power supply
- Motor under-load and over-current control
- Direct connection up to 16A max or by current transformer (CT)
- Excellent tripping accuracy
- Voltage control range 80...660VAC
- Current control range 0.1...16A
- Resetting and enabling consent input
- 1 relay output relay with 1 changeover contact (SPDT)
- Modular DIN 43880 housing, 3 modules
- Mounting on 35mm DIN rail (IEC/EN/BS 60715) or screw fixing via pull out tabs
- IEC degree of protection: IP40 on front (only when placed in IP40 enclosure or control board); IP20 at terminals.

ADJUSTMENTS

- "Cos ϕ min" Minimum $\cos\phi$ threshold 0.1...0.99 (under-load/dry running)
- "I $_{max}$ " Maximum current threshold 10...100% I_e
- "Trip delay" Tripping time for minimum $\cos\phi$ and maximum current 0.1...10s
- "Inhibition time" Inhibition delay for external input or at power up 1...60s
- "Aut. reset delay" Automatic reset time OFF...100min
- "Mode"
 - Rated current 5A or 16A
 - Single or three phase
 - External reset ON or OFF.

Certifications and compliance

Certifications obtained: UL Listed, for USA and Canada (cULus - File E93601), as Auxiliary Devices - Modular ampere monitoring relays; EAC.
Compliant with standards: IEC/EN/BS 60255-27, IEC/EN/BS 61000-6-2, IEC/EN/BS 61000-6-3, UL 508, CSA C22.2 n° 14.

For low voltage



PMVF20...

Order code	Rated voltage		Qty per pkg	Wt
	Control	Auxiliary		
	[V]	[V]	n°	[kg]
PMVF20	230VAC 400VAC	100...400VAC/ 110...250VDC	1	0.568
PMVF20D048		12...48VDC	1	0.580

Low voltage system.
Dual threshold minimum and maximum voltage and frequency protection.
Flush mount type 96x96mm/3.78x3.78".

Voltage threshold per CEI 0-21

Type of protection	Tripping threshold	Tripping time
Maximum voltage 59.S2	1.15Un	0.2s
Maximum voltage 59.S1 (moving mean over 10min)	1.10Un	≤ 3s
Minimum voltage 27.S1	0.85Un	1.5s
Minimum voltage 27.S2	0.15Un	0.2s

Frequency threshold per CEI 0-21

Type of protection	Tripping threshold	Tripping time
High external signal and low local control conditions.		
Maximum frequency 81>.S2	51.5Hz	0.1s
Minimum frequency 81<.S2	47.5Hz	0.1s
Low external signal and high local control conditions.		
Maximum frequency 81>.S2	51.5Hz	1s
Minimum frequency 81<.S2	47.5Hz	4s
High conditions for both external signal and local control.		
Maximum frequency 81>.S1	50.2Hz	0.1s
Minimum frequency 81<.S1	49.8Hz	0.1s

NOTE: Low conditions for both external signal and local control are not taken into consideration by the standard.

Order code	Description
EXPANSION MODULES FOR PMVF20. For independent signal in case of phase power unbalance (LSP).	
EXP1003	2 relay outputs 5A 250VAC
Communication ports.	
EXP1010	Opto-isolated USB interface
EXP1011	Opto-isolated RS232 interface
EXP1012	Opto-isolated RS485 interface
EXP1013	Opto-isolated Ethernet interface
EXP1018 Ⓢ	IEC/EN/BS 61850 interface

Ⓢ IEC/EN/BS 61850 protocol

The EXP1018 module will be made available only when the competent authorities have established the exact terms of the supervision and control of the specific commands (currently under study as specified in the Italian CEI 0-21 standard).



EXP1003



PMVFUPS01

new

Order code	Description	Qty per pkg	Wt
Backup power supply for interface protection unit PMVF20.			
PMVFUPS01	Input 230VAC Output 230VAC with stored energy 200Ws and power 250VA	1	0.500

General characteristics

PMVF20 interface protection system (IP) unit has been developed according to the Italian CEI 0-21 standard prescriptions. It is used when a local generating system is connected in parallel with the low-voltage electric utility. The controls refer to limits of voltage and frequency monitoring.

In the case when either the voltage or the frequency are out of admissible limits, PMVF... must step in by de-energising a relay output so that the interface device (DDI) trips.

PMVF20 is equipped with 4 inputs having the following functions:

- DDI status feedback
- External signal for frequency selection (communication network malfunction)
- Local control for frequency selection
- Remote tripping (forced DDI opening independent of voltage and frequency values).

Also, there are two relay outputs for:

- DDI opening and closing
- Standby device opening (programmable: retentive normally energised, retentive normally de-energised or adjustable pulse).

The standby device control is compulsory in installations with more than 20kW and consists of a signal, with a 0.5s delay respect to the DDI opening command, transmitted only if the DDI fails and does not complete the disconnection.

By fitting the EXP10 03 expansion module on the PMVF20, the following functions can be configured as:

- Programmable alarm
- Autonomous signalling in case of phase power unbalance (LSP), only if three CTs are also installed.

Operational characteristics

- Auxiliary voltage:
 - PMVF20: 100...400VAC/110...250VDC
 - PMVF20 D048: 12...48VDC
- Voltage inputs:
 - 400VAC (three-phase connection)
 - 230VAC (single-phase connection)
- Relay outputs 5A 250VAC AC1 / 5A 30VDC
- 4 digital inputs
- Current inputs (optional): Use via CTs with selectable /5A or /1A secondary
- Parameter configuration and remote control (only with communication expansion module) with software **Synergy** and **Xpress**
- Housing: Flush mount 96x96mm/3.78x3.78"
- IEC degree of protection: IP65 on front; IP20 on terminals
- **Predisposed for IEC/EN/BS 61850 signal supervision using expansion or external module**Ⓢ.

Reference standards

Compliant with standards: Italian CEI 0-21, IEC/EN/BS 60255-27, IEC/EN/BS 61010-1, IEC/EN/BS 61000-6-2, IEC/EN/BS 61000-6-3.

Synergy: Supervision and Energy management software with remote and configuration capabilities.

Xpress: Free software for Energy management controlling one device only.

See section 30.

General characteristics for PMVFUPS01

See page 19-13.

For low voltage



PMVF51

Order code	Rated voltage		Qty per pkg	Wt
	Control	Auxiliary		
	[V]	[V]	n°	[kg]
PMVF51	230VAC 400VAC	100...240VAC/ 110...250VDC	1	0.470

Low voltage system.
Dual threshold minimum and maximum voltage and frequency protection.
Modular type with 2 relay outputs.

Voltage threshold per CEI 0-21

Type of protection	Tripping threshold	Tripping time
Maximum voltage 59.S2	1.15Un	0.2s
Maximum voltage 59.S1 (moving mean over 10min)	1.10Un	≤ 3s
Minimum voltage 27.S1	0.85Un	1.5s
Minimum voltage 27.S2	0.15Un	0.2s

Frequency threshold per CEI 0-21

Type of protection	Tripping threshold	Tripping time
High external signal and low local control conditions.		
Maximum frequency 81>.S2	51.5Hz	0.1s
Maximum frequency 81<.S2	47.5Hz	0.1s
Low external signal and high local control conditions.		
Maximum frequency 81>.S2	51.5Hz	1s
Minimum frequency 81<.S2	47.5Hz	4s

High conditions for both external signal and local control.		
Maximum frequency 81>.S1	50.2Hz	0.1s
Minimum frequency 81<.S1	49.8Hz	0.1s

NOTE: Low conditions for both external signal and local control are not taken into consideration by the standard.

Order code	Description
EXPANSION MODULES FOR PMVF51. Communication ports.	
EXM1010	Opto-isolated USB interface
EXM1011	Opto-isolated RS232 interface
EXM1012	Opto-isolated RS485 interface
EXM1013	Opto-isolated Ethernet interface
EXM1018	IEC/EN/BS 61850 interface
Inputs and outputs.	
EXM1001	2 digital opto-isolated inputs and 2 relay outputs 5A 250VAC

IEC/EN/BS 61850 protocol

The EXM1018 module will be made available only when the competent authorities have established the exact terms of the supervision and control of the specific commands (currently under study as specified in the Italian CEI 0-21 standard).



EXM10...



PMVFUPS01

new

Order code	Description	Qty per pkg	Wt
Backup power supply for interface protection unit PMVF51.			
PMVFUPS01	Input 230VAC Output 230VAC with stored energy 200Ws and power 250VA	1	0.500

General characteristics

PMVF51 interface protection system (IP) unit has been developed according to the Italian CEI 0-21 standard prescriptions. Each is used when a local solar generating system is connected in parallel with the low-voltage electric utility. The controls refer to limits of voltage and frequency monitoring.

In the case when either the voltage or the frequency are out of admissible limits, PMVF51 must step in by de-energising a relay output so that the interface device (DDI) trips. PMVF51 is certified for use in single and three phase systems, where it is required in presence of storage systems connected in parallel to the distribution network and to the photovoltaic inverter on the AC side (presence of multiple energy generators simultaneously or exceeding the threshold of 11.08kW overall).

PMVF51 is equipped with 4 inputs having the following functions:

- DDI status feedback
- External signal for frequency selection (communication network malfunction)
- Local control for frequency selection
- Remote tripping (forced DDI opening, independent of voltage and frequency values).

Also, there are two relay outputs for:

- DDI opening and closing
- Standby device opening (programmable: retentive normally energised, retentive normally de-energised or adjustable pulse).

The standby device control is compulsory in installations with more than 20kW and consists of a signal, with a 0.5s delay respect to the DDI opening command, transmitted only if the DDI failed and did not complete the disconnection.

PMVF51 also has two additional relay outputs (EXM1001) to configure as:

- Programmable alarm
- Autonomous signalling in case of phase power unbalance (LSP), only if three CTs are also installed.

Operational characteristics

- Auxiliary voltage: 100...240VAC/110...250VDC
- Voltage inputs:
 - 400VAC (three-phase connection)
 - 230VAC (single-phase connection)
- Relay outputs 5A 250VAC AC1 / 5A 30VDC
- 4 digital inputs
- Current inputs (optional): Use via CTs with selectable /5A or /1A secondary
- Parameter configuration and remote control (only with communication expansion module) with software **Synergy** and **Xpress**
- Modular housing (6 modules)
- Mounting on 35mm DIN rail (IEC/EN/BS 60715) or screw fixing via pull out tabs
- Degree of protection for both: IP40 on front; IP20 on terminals
- **Predisposed for IEC/EN/BS 61850 signal supervision using expansion or external module** .

Reference standards

Compliant with standards: Italian CEI 0-21, IEC/EN/BS 60255-27, IEC/EN/BS 61010-1, IEC/EN/BS 61000-6-2, IEC/EN/BS 61000-6-3.

Synergy: Supervision and Energy management software with remote and configuration capabilities.

Xpress: Free software for Energy management controlling one device only.
See section 30.

General characteristics for PMVFUPS01

CEI 0-21 and CEI 0-16 standards require an auxiliary power supply to feed the interface protection (IP), the interface switch (IS) and the backup switch for at least 5 seconds in the event of a power failure. PMVFUPS01 guarantees the necessary energy by accumulating it in capacitors, thus avoiding the use of batteries that require maintenance.

- Power supply: 230VAC, 50Hz
- Output voltage: 230VAC, 50Hz
- Output power: 250VA
- Accumulated energy: 200Ws
- Accumulation time: 15s
- 9U modular housing
- Operating temperature: -5...+ 55°C
- Degree of protection IP20.

Reference standards

Compliant with standards: IEC/EN/BS 61010-1.

For medium voltage



PMVF30...

Voltage threshold per CEI 0-16

Order code	Rated voltage		Qty per pkg	Wt [kg]
	Control [V]	Auxiliary [V]		
PMVF30	Measurements via VTs in MV or direct in LV	100...400VAC/110...250VDC	1	0.566
PMVF30D048		12...48VDC	1	0.566

Medium-voltage system.
Dual threshold minimum and maximum voltage and frequency protection.
Flush mount type 96x96mm/3.78x3.78".

Type of protection	Tripping threshold	Tripping time
Maximum voltage 59.S2	1.2Un	0.6s
Maximum voltage 59.S1 (moving mean over 10min)	1.1Un	≤ 3s
Minimum voltage 27.S1	0.85Un	0.4s
Minimum voltage 27.S2	0.15Un	0.2s
Maximum residual voltage 59.V0 (59N)	5% Urn	25s

Frequency threshold per CEI 0-16
Frequency protection at voltage choice

Type of protection	Tripping threshold	Tripping time
Configuration in standard conditions.		
Maximum frequency 81>.S2	51.5Hz	1s
Minimum frequency 81<.S2	47.5Hz	4s
Limited configuration in case of local control or voltage choice condition.		
Maximum frequency 81>.S1	50.2Hz	0.15s
Minimum frequency 81<.S1	49.8Hz	0.15s
– Voltage choice functions		
Maximum residual voltage 59.V0 (59N)	5% Urn	-
Minimum direct sequence voltage 27.Vd	70% Un	-
Maximum inverse sequence voltage 59.Vi	15% Un	-

Order code	Description
EXPANSION MODULES FOR PMVF30. For auto reclosing management of automatic circuit breaker (DDI).	
EXP1003	2 relay outputs 5A 250VAC
Communication ports.	
EXP1010	Opto-isolated USB interface
EXP1011	Opto-isolated RS232 interface
EXP1012	Opto-isolated RS485 interface
EXP1013	Opto-isolated Ethernet interface
EXP1018Ⓢ	IEC/EN/BS 61850 interface

Ⓢ IEC/EN/BS 61850 protocol
The EXP1018 module will be made available only when the competent authorities have established the exact terms of the supervision and control of the specific commands (currently under study as specified in the Italian CEI 0-16 standard).



EXP10...



PMVFUPS01

new

Order code	Description	Qty per pkg	Wt
Backup power supply for interface protection unit PMVF30.			
PMVFUPS01	Input 230VAC Output 230VAC with stored energy 200Ws and power 250VA	1	0.500

General characteristics

PMVF30 interface protection system (IP) unit has been developed according to the Italian CEI 0-16 standard prescriptions. It is used when a local generating system is connected in parallel with the medium-voltage utility distribution grid. The controls refer to limits of voltage and frequency monitoring.

In the case when either the voltage or the frequency are out of admissible limits, PMVF... must step in by de-energising a relay output so that the interface device (DDI) trips.

PMVF30 is equipped with inputs having the following functions:

- DDI status feedback
- Interface protection system exclusion
- Local control
- Remote tripping (forced DDI opening, independent of voltage and frequency values).

In addition, there are two relay outputs to configure as:

- DDI opening
- Programmable (either as factory default for standby device opening or to set up as auto reclosing if the DDI is an automatic circuit breaker).

Standby device opening

In installations with more than 400kW, the standard specifies there must be a command signal, that releases another standby device, given within 1 second whenever the DDI opening fails or malfunctions.

Automatic DDI reclosing

Whenever an automatic circuit breaker is used as the DDI, the PMVF30 is capable of controlling both the opening (according to the installation conditions indicated in the Italian CEI 0-16 standard) and the auto reclosing. The auto reclosing function includes defining the number of attempts and the time interval between an attempt and the following one as well as generating an alarm if the closing operation does not take place.

This function can be carried out through a programmable output of the PMVF30 (unless it is already used for the standby device operation) or by installing an EXP1003 expansion module.

Operational characteristics

- Auxiliary voltage:
 - PMVF30: 100...400VAC/110...250VDC
 - PMVF30D048: 12...48VDC
- Voltage inputs (connection via VTs in MV or directly in LV end):
 - Primary: until 150,000V
 - Secondary: 50...500V (for voltage/frequency); 50...150V (for residual voltage measurement)
- Relay outputs 5A 250VAC AC1 / 5A 30VDC
- 4 digital inputs
- 3 current inputs (for optional measuring): Use via CTs with selectable /5A or /1A secondary
- Parameter configuration and remote control (only with communication expansion module) with software **Synergy** and **Xpress**
- Housing: Flush mount 96x96mm/3.78x3.78"
- Degree of protection: IP65 on front; IP20 on terminals
- **Predisposed for IEC/EN/BS 61850 signal supervision using expansion or external moduleⓈ.**

Reference standards

Compliant with standards: Italian CEI 0-16; IEC/EN/BS 60255-27, IEC/EN/BS 61010-1, IEC/EN/BS 61000-6-2, IEC/EN/BS 61000-6-3.

Synergy: Supervision and Energy management software with remote and configuration capabilities.

Xpress: Free software for Energy management controlling one device only. See section 30.

General characteristics for PMVFUPS01

See page 19-13.

19 Monitoring relays

Interface protection system units compliant with standards ENA G59-3/G99, SHAMS DUBAI - DRRG STANDARDS (DEWA), VDE-AR-N 4105, VDE V 0126-1-1, SEC (Saudi Electricity Company)



PMVF...

new

Order code	Rated voltage Control	Auxiliary	Qty per pkg	Wt
	[V]	[V]	n°	[kg]
Dual threshold minimum and maximum voltage and frequency protection, R.O.C.O.F. and Vector shift. Modular type.				
Compliant with standards DEWA DRRG and SEC (Saudi Electricity Company).				
PMVF60	Programmable	100...240VAC/ 110...250VDC	1	0.470
Compliant with standards ENA G59-3/G99.				
PMVF70	Programmable	100...240VAC/ 110...250VDC	1	0.470
Compliant with standards VDE-AR-N 4105 e VDE V 0126-1-1.				
PMVF80	Programmable	100...240VAC/ 110...250VDC	1	0.470

Voltage threshold

Protection type	PMVF60	PMVF70	PMVF80
Maximum voltage threshold 2	●	●	●
Maximum voltage threshold 1	● (10 min. average)	●	● (10 min. average)
Minimum voltage threshold 1	●	●	●
Minimum voltage threshold 2	●	●	●

Frequency threshold

Protection type	PMVF60	PMVF70	PMVF80
Maximum frequency threshold 2	Optional set to OFF	●	●
Maximum frequency threshold 1	●	●	Optional set to OFF
Minimum frequency threshold 1	●	●	Optional set to OFF
Minimum frequency threshold 2	Optional set to OFF	●	●



EXM10...

Order code	Description
EXPANSION MODULES FOR PMVF... Communication ports.	
EXM1010	Opto-isolated USB interface
EXM1011	Opto-isolated RS232 interface
EXM1012	Opto-isolated RS485 interface
EXM1013	Opto-isolated Ethernet interface
EXM1018 Ⓢ	IEC/EN/BS 61850 interface
Inputs and outputs.	
EXM1001	2 digital inputs, opto-isolated and 2 relay outputs, rated 5A 250VAC

Ⓢ IEC/EN/BS 61850 protocol

The EXP1018 module will be made available only when the competent authorities have established the exact terms of the supervision and control of the specific commands (currently under study as specified in the Italian CEI 0-16 standard).

General characteristics

PMVF... interface protection system (IP) units have been developed in order to be used when a local generating system is connected in parallel with the utility distribution grid. The controls refer to limits of voltage and frequency monitoring.

In the case when either the voltage or the frequency are out of admissible limits, the PI must step in by de-energising a relay output so that the interface device (IS) trips.

PMVF... is equipped with 4 inputs having the following functions:

- IS status feedback
- R.O.C.O.F/Vector shift delay or external signal for frequency selection (communication network malfunction)
- Disabling signal
- Remote tripping (forced IS opening, independent of voltage and frequency values).

Also, there are two relay outputs for:

- IS opening and closing
- Standby device opening (programmable: retentive normally energised, retentive normally de-energised or adjustable pulse).

The backup device consists of a signal contemporary or delayed respect to the IS opening command, transmitted only if the IS failed and did not complete the disconnection. PMVF... also has two additional relay outputs (EXM1001) to configure as:

- Programmable alarm
- Autonomous signalling in case of phase power unbalance (LSP), only if three CTs are also installed.

Operational characteristics

- Auxiliary voltage: 100...240VAC/110...250VDC
- Voltage inputs:
 - 400VAC (three-phase connection)
 - 230VAC (single-phase connection)
- Relay outputs 5A 250VAC AC1 / 5A 30VDC
- 4 digital inputs
- Current inputs (optional): use via CTs with selectable /5A or /1A secondary
- Support of EXM series communications ports (USB, RS232, RS485, Ethernet) see section 31
- Parameter configuration and remote control (only with communication expansion module) with software **Synergy** and **Xpress**
- Modular housing (6 modules)
- Mounting on 35mm DIN rail (IEC/EN/BS 60715) or screw fixing via pull out tabs
- Degree of protection for both: IP40 on front; IP20 on terminals
- **Predisposed for IEC/EN/BS 61850 signal supervision using expansion or external module**Ⓢ.

Reference standards

Compliant with standards: DEWA DRRG (PMVF60); SEC (PMVF60); ENA G59-3/G99 (PMVF70); VDE-AR-N 4105, VDE V 0126-1-1 (PMVF80); IEC/EN/BS 60255-27; IEC/EN/BS 61010-1, IEC/EN/BS 61000-6-2, IEC/EN/BS 61000-6-4.

Synergy: Supervision and Energy management software with remote and configuration capabilities.

Xpress: Free software for Energy management controlling one device only. See section 30.

Remote control and monitoring GSM modem via SMS

Compliant with Italian CEI 0-16 Standard, paragraph 8.8.6.5 and annex M, resolution 421/2014 of the ARERA



EXCGSM01

Order code	Description
	GSM Modem (modular - 4U). IP69K outside aerial with 2.5m cable. RJ45-USB programming cable (included).
EXCGSM01	100...240VAC, 1 digital input, 1 analogic input (0...10V, 0...20mA, NTC), 1 relay output

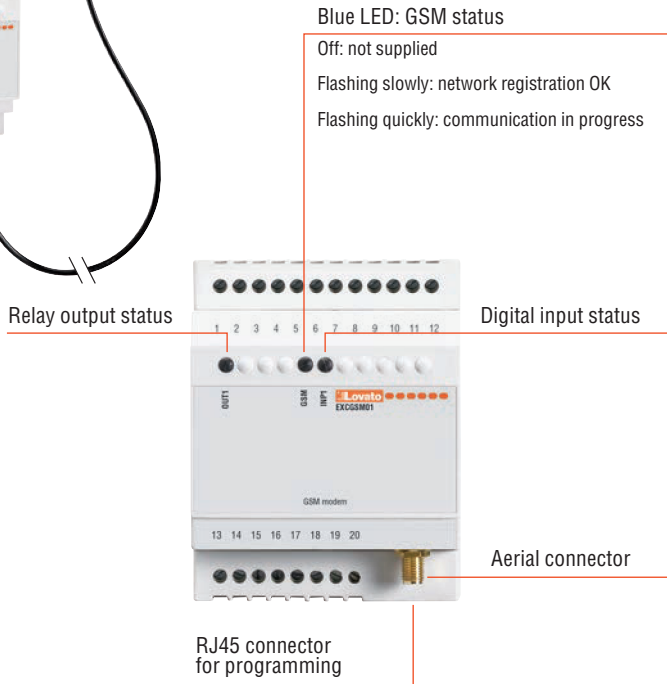

General characteristics

With EXCGSM01 it is possible to remotely operate a relay output and obtain information on the system by sending programmable SMS. Using the configuration software (downloaded for free from www.LovatoElectric.com) the user can control the relay output and both the digital and analog inputs. The logic is based on events (for example, the activation of the digital input or the arrival of an SMS with specific text), to which the user can decide specific actions (reply either by SMS or voice message, or by switching the relay output).

Use with CEI 0-16

The CEI 0-16 standard in paragraph 8.8.6.5 and in attachment M prescribes that the electricity production plants powered by wind or solar photovoltaic sources with power greater than or equal to 100kW, connected or to be connected to medium voltage grids, are equipped with GSM modem. Thanks to this modem it is possible to manage the disconnection of the generation through the messages sent by the energy distributor.

Functional characteristics

- Connection to the GSM network for sending and receiving SMS messages
 - Programmable message texts
 - Command output piloted by SMS or internal logic, for example to send the remote disconnection command to the interface device CEI 0-16
 - Programmable digital input, for example to detect the status of the Interface Switch (IS) and sending of successful IS opening and closing SMSs
 - POD management (active user code)
 - Management of the list of caller IDs (CLI) up to 5000 callers enabled
 - Detection of mobile network coverage
 - Full compatibility with medium-voltage PI LOVATO Electric PMVF30: no software/hardware updates or programming required
 - **Compatibility with third-party PIs where the remote disconnection signal is transmitted via digital input (dry contact)**
- For additional information contact our Technical support
Tel. + 39 035 4282422; E-mail: service@LovatoElectric.com.

Software

To configure the EXCGSM01 modem (using the RJ45-USB programming cable included), the EXCGSMSW software must be used. This can be downloaded for free from the www.LovatoElectric.com website. The software allows you to set:

- the users enabled to exchange messages with the modem
 - the identifier of the modem, for example the active customer code (POD) in CEI 0-16 applications;
 - the functions assigned to the digital output and input and to analog input;
 - the texts of the SMS associated with the commands
 - the logic of the actions taken following the SMS arrival, change of input status, alarm situations.
- Configuration is also possible off-line, creating a file to transfer to the modem at another time.

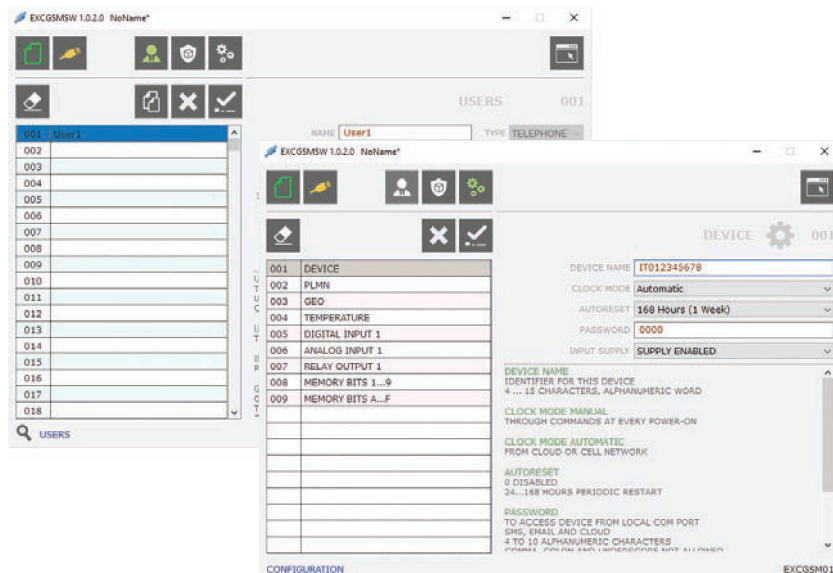

Operational characteristics

- MODEM**
- 35mm DIN (IEC/EN/BS 60715) rail fixing
 - 4 modules
 - Supply: 100...240VAC
 - Consumption: 5VAC
 - 1 digital output 3A 250VAC
 - 1 self-supplied digital input
 - 1 analog input 0...10V, 0...20mA, NTC
 - Housing for 3V and 1.8V SIM card
 - SIM PIN management
 - Temperature sensor
 - Update time, sunrise and sunset via GSM network
 - Position update via GSM
 - Certified according to FCC rules, part 15B
 - Operating temperature: -20...+60°C
 - Protection rating: IP40 on front; IP20 on terminals.

AERIAL

- Quad band 850/900/1800/1900MHz
- Degree of protection: outside IP69K
- 2.5m cable
- Fixing via M10 hole:
 - with adhesive seal
 - with threaded pin and nut.

Compliance

Compliant with electrical safety standards: EN/BS 62368, EN/BS 62311.

PMVF20...

Three-phase connection

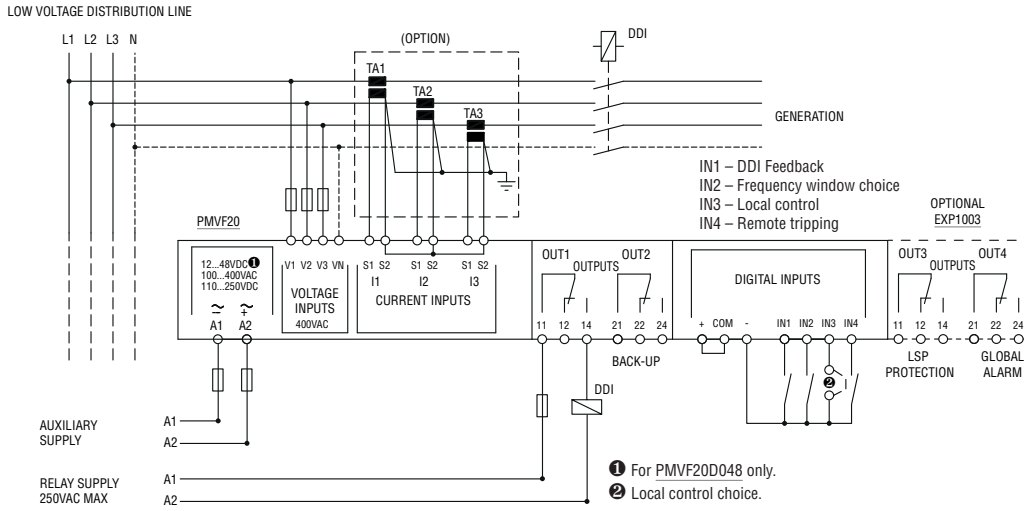

Rear view

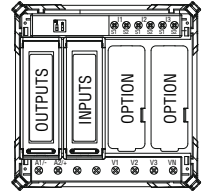

PMVF51

Three-phase connection

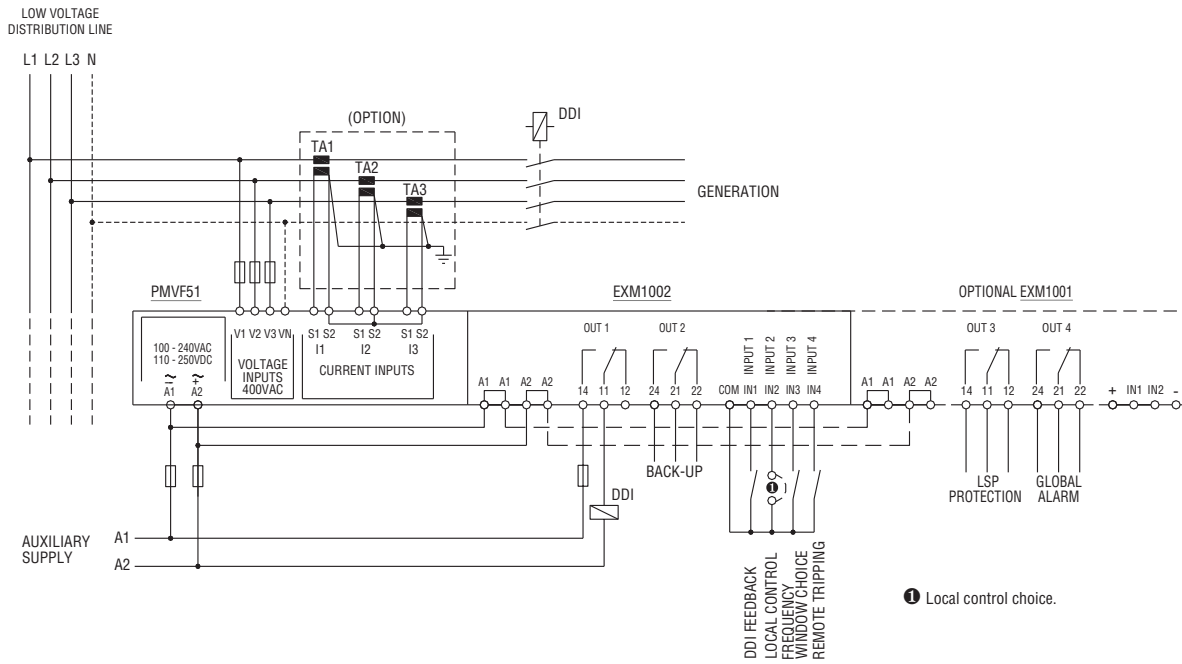

PMVF60

Three-phase connection

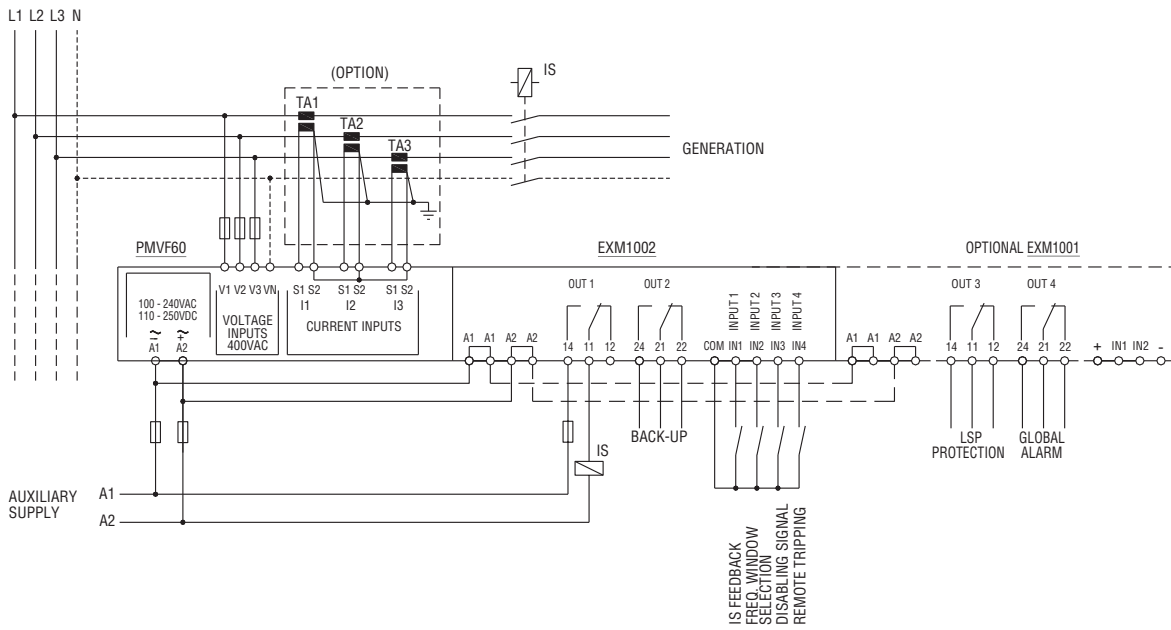

PMVF70 - PMVF80

Three-phase connection

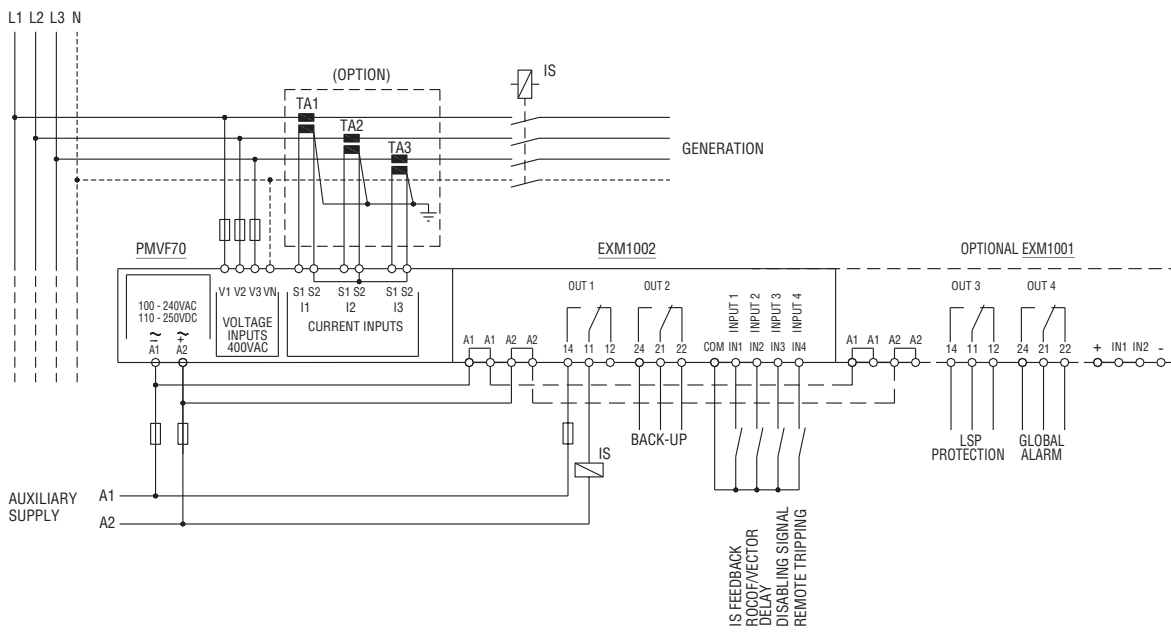

PMVF30...

Connection through VTs in Medium Voltage
Three-phase connection

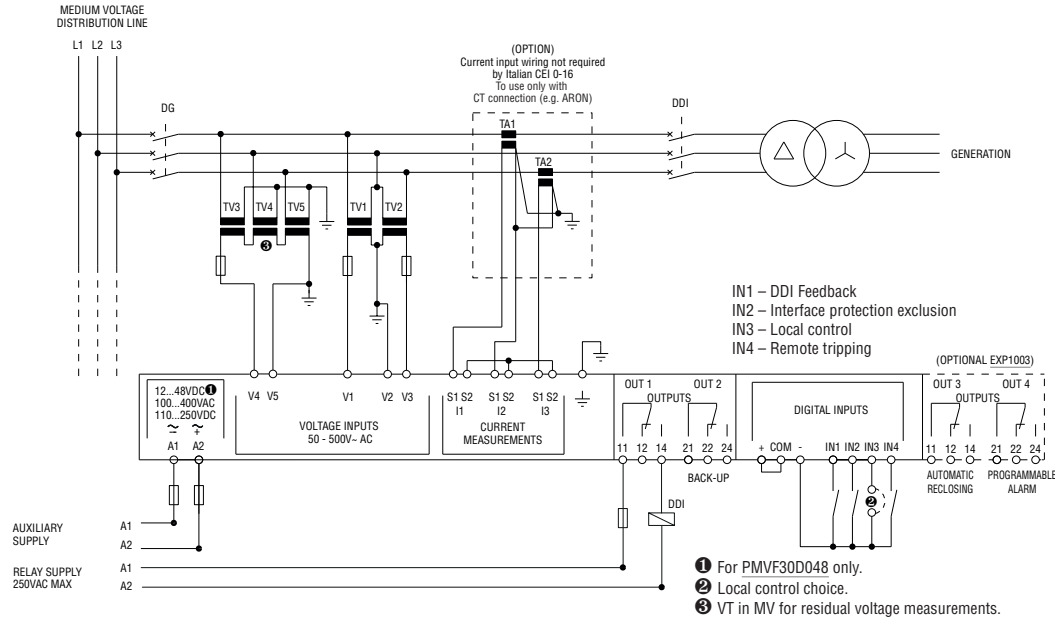

Rear view

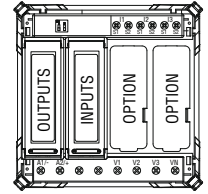

Direct connection in Low Voltage Three-phase connection

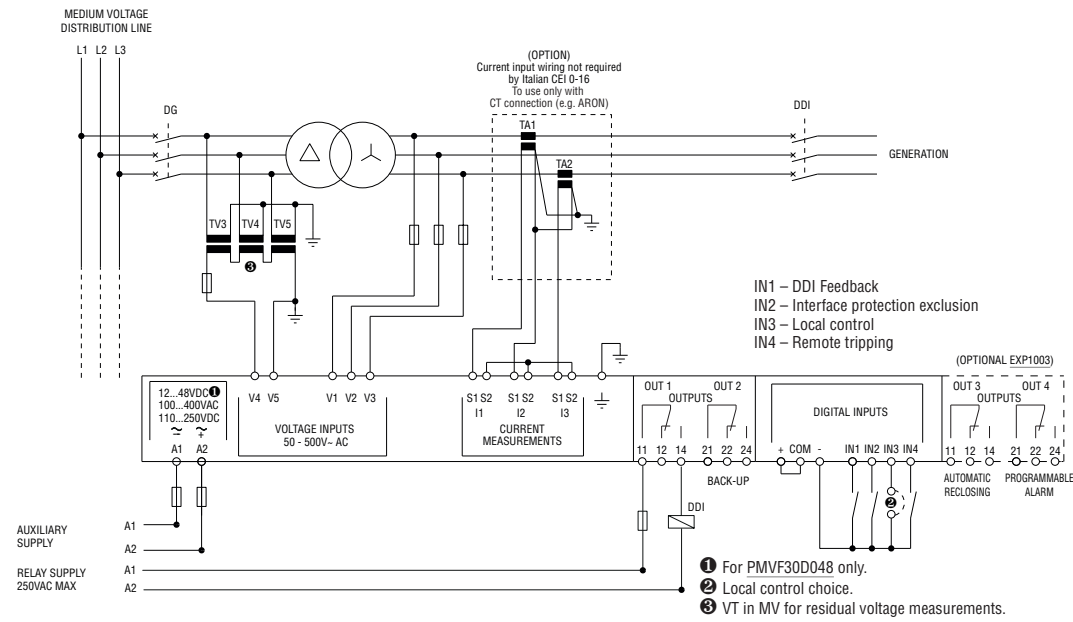

Rear view

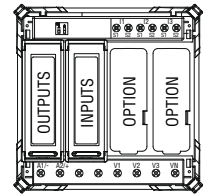

PMVFUPS01

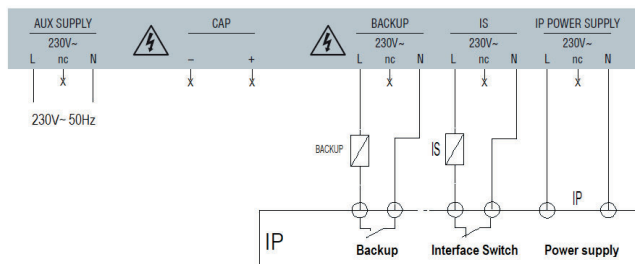

PMVF30... with EXCGSM01

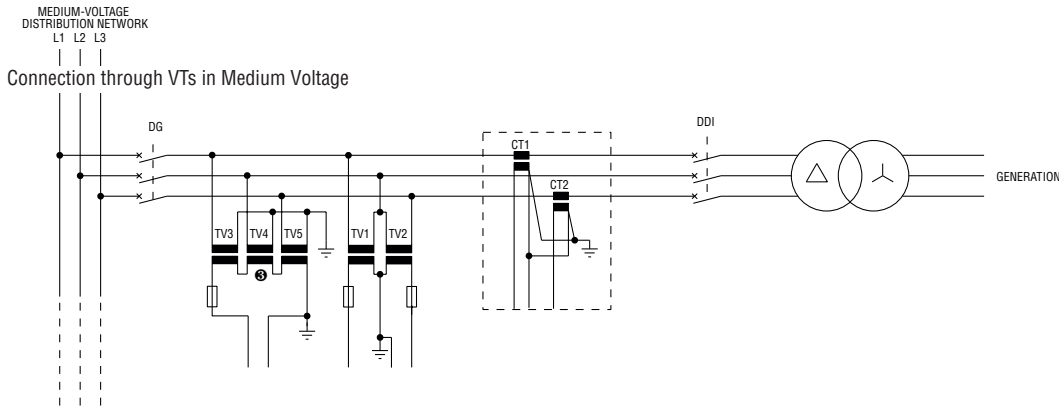

Direct connection in Low Voltage - Three-phase connection

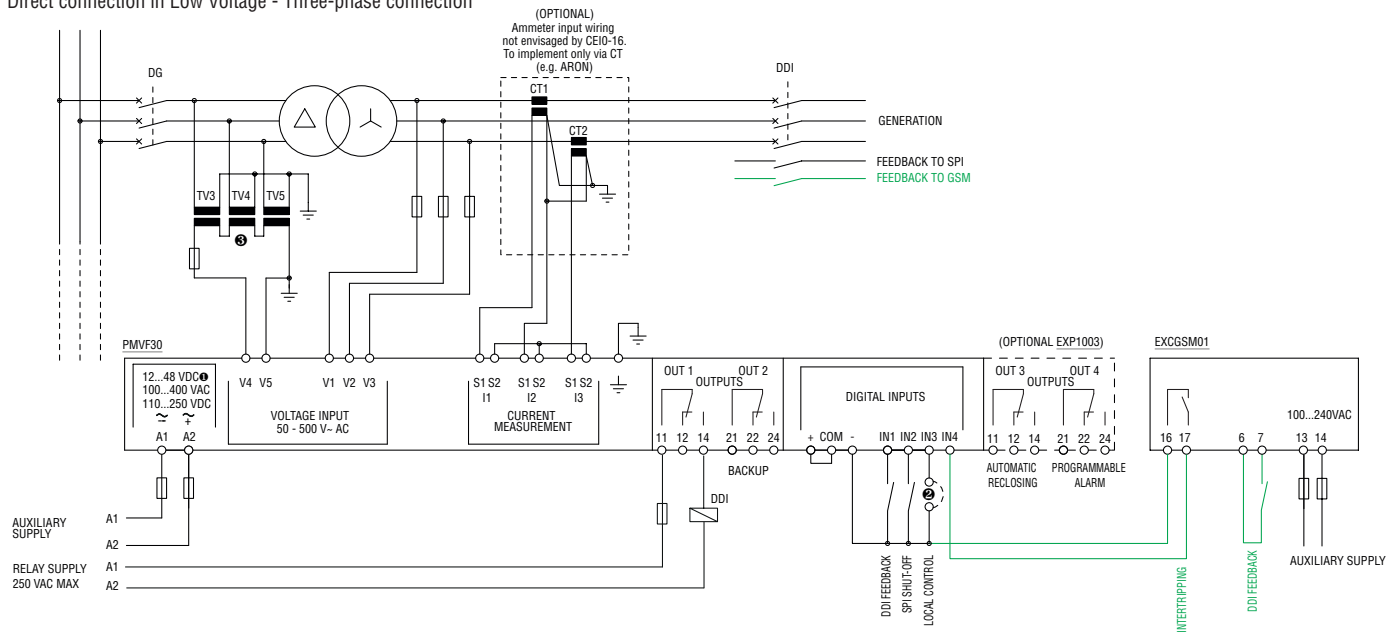

- ❶ For PMVF30D048 only.
- ❷ Local control choice.
- ❸ VT in MV for residual voltage measurements.

The connections coloured in GREEN, in addition to the GSM Modem, represent the only wiring necessary for the adaptation.

EXCGSM01 modem wiring diagram with other interface protections (PI) with self-supplied remote disconnection input

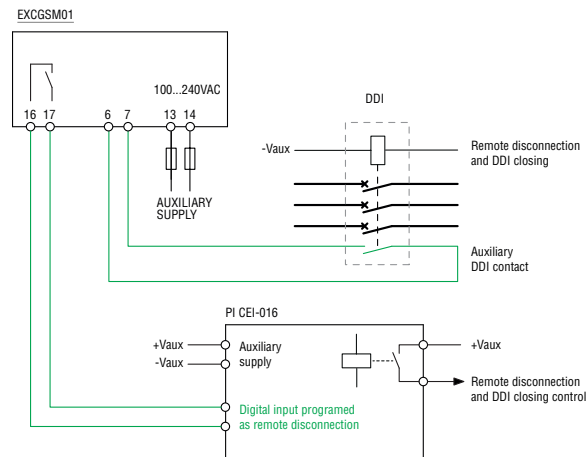

The connections coloured in GREEN, in addition to the GSM Modem, represent the only wiring necessary for the adaptation.

EXCGSM01 modem wiring diagram with other interface protections (PI) with remote disconnection input to be supplied

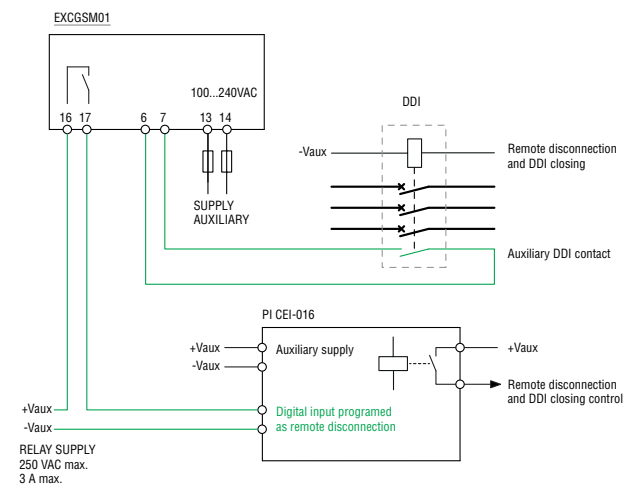

19 Monitoring relays

Technical characteristics Voltage monitoring relays



INDEX

TYPE	Single phase	PMV55	—	—	—	—	—
	Three phase	—	PMV10	PMV20	PMV30	PMV40	—
	Three phase with/without neutral	—	—	—	—	—	—
DESCRIPTION							
	Minimum and maximum AC voltage		Phase loss and incorrect phase sequence		Minimum AC voltage, phase loss and incorrect phase sequence		Asymmetry, phase loss and incorrect phase sequence
CONTROL CIRCUIT							
Rated voltage to control (Ue)	110...127VAC	208...480VAC	100...240VAC	208...240VAC			
	208...240VAC		208...575VAC	380...575VAC			
	380...440VAC		380...600VAC	600VAC			
Maximum voltage set-point	105...115% Ue	—	—	—	—	—	—
Minimum voltage set-point	80...95% Ue	—	—	80...95% Ue	—	—	—
Asymmetry set-point	—	—	—	—	—	5...15%Ue	—
Minimum and maximum frequency set-point	—	—	—	—	—	—	—
Tripping time	0.1...20s	60ms		0.1...20s			
Resetting time	0.1...20s (0.5s at power up)	0.5s		0.1...20s (0.5s at power up)			
Resetting hysteresis	3%	5%		3%			
Instantaneous tripping for Ue	<70% Ue configured	Umin<70% Ue		<70% Ue configured	<70% Ue configured		
Repeat accuracy	< ±0.1%	< ±1%		< ±0.1%	< ±0.1%		
POWER SUPPLY							
Auxiliary voltage (Us)	Self powered						
Operating range	0.7...1.2Ue	0.85...1.1Ue		0.7...1.2Ue			
Frequency	50/60Hz ±5%						
Power consumption (maximum)	10VA (208...240VAC)❶ 17VA (380...440VAC)❶	20VA❶	28VA❶	11VA (208...240VAC)❶ 30VA (380...575VAC)❶ 19VA (600VAC)❶			
Power dissipation (maximum)	1.5W	2.2W		2.5W			
RELAY OUTPUTS							
Number of relays	1						
Relay state	Normally energised De-energises at tripping						
Contact arrangement	1 changeover SPDT						
Rated operational voltage	250VAC						
Maximum switching voltage	400VAC						
Conventional free-air thermal current (Ith)	8A						
UL/CSA and IEC/EN/BS 60947-5-1 designation	B300						
Electrical life (with rated load)	10 ⁵ cycles						
Mechanical life	30x10 ⁶ cycles						
Indications	1 green LED for power on and tripping 2 red LEDs for tripping	1 green LED for power on and tripping		1 green LED for power on and tripping 1 red LED for tripping			
CONNECTIONS							
Terminal tightening torque (maximum)	0.8Nm (7lb.in; 7...9lb.in for UL/CSA)						
Conductor section min...max	0.2...4.0mm ² (24...12AWG; 18...12AWG for UL/CSA)						
INSULATION (input-output)							
IEC rated insulation voltage Ui	440VAC	480VAC	600VAC				
IEC rated impulse withstand voltage Uimp	6kV						
IEC power frequency withstand voltage	4kV						
AMBIENT CONDITIONS							
Operating temperature	-20...+60°C						
Storage temperature	-30...+80°C						
HOUSING							
Material	Self-extinguishing polyamide						

❶ Power consumption (maximum) at 50Hz.

19 Monitoring relays

Technical characteristics
Voltage monitoring relays

	—	—	—	—	—	—
	PMV50	PMV70	—	—	—	—
	—	—	PMV50N	PMV70N	PMV80N	PMV95N
	Minimum and maximum AC voltage, phase loss and incorrect phase sequence	Minimum and maximum AC voltage, phase loss, incorrect phase sequence and asymmetry	Minimum and maximum AC voltage, phase loss, neutral loss and incorrect phase sequence	Minimum and maximum AC voltage, phase loss, neutral loss, incorrect phase sequence and asymmetry	Minimum and maximum AC voltage and frequency, phase loss, neutral loss and incorrect phase sequence	Minimum and maximum AC voltage and frequency, phase loss, neutral loss, incorrect phase sequence and asymmetry
	208...240VAC	208...240VAC	208...240VAC	208...240VAC	208...240VAC	208...240VAC
	380...575VAC	380...440VAC	380...440VAC	380...440VAC	380...440VAC	380...575VAC
	600VAC	600VAC	480...600VAC	480...600VAC	480...600VAC	—
	105...15% Ue	105...115% Ue	105...115% Ue	105...115% Ue	105...115% Ue	105...115% Ue
	80...95% Ue	80...95% Ue	80...95% Ue	80...95% Ue	80...95% Ue	80...95% Ue
	—	5...15% Ue	—	5...15% Ue	—	5...15% Ue
	—	—	—	—	±1...10% rated frequency	±1...10% rated frequency
	0.1...20s				0.1...20s	0.1...5s freq.
	0.1...20s (0.5s at power up)	0.5s	0.1...20s (0.5s at power up)	0.5s	0.5s	0.1...30s (0.5s at power up)
	3%	3%	3%	3%	3% 0.5% freq.	1...5%
	<70% Ue configured < ±0.1%					
	Self powered					
	0.7...1.2Ue					
	50/60Hz ±5%	50/60Hz ±10%				
	11VA (208...240VAC)ⓘ 30VA (380...575VAC)ⓘ 19VA (600VAC)ⓘ	27VA			30VA	
	2.5W	1.9W			2.5W	
	1	2			1	
	Normally energised De-energises at tripping					
	1 changeover SPDT	2 changeover SPDT			1 changeover SPDT	
	250VAC					
	400VAC					
	8A					
	B300					
	10 ⁵ cycles					
	30x10 ⁶ cycles					
	1 green LED for power on and tripping 2 red LEDs for tripping	1 green LED for power on and tripping 3 red LEDs for tripping	1 green LED for power on and tripping 2 red LEDs for tripping	1 green LED for power on and tripping 3 red LEDs for tripping		1 green LED for power 5 red LEDs for tripping
	0.8Nm (7lb.in; 7...9lb.in for UL/CSA - PMV50N/70N/80N excluded)					
	0.2...4.0mm ² (24...12AWG; 18...12AWG for UL/CSA - PMV50N/70N/80N excluded)					
	600VAC					
	6kV					
	4kV					
	-20...+60°C					
	-30...+80°C					
	Self-extinguishing polyamide					

19 Monitoring relays

Technical characteristics
Current monitoring relays

TYPE	PMA20	PMA30	PMA40
DESCRIPTION	Single-phase maximum current monitoring AC/DC multiscale	Single-phase minimum or maximum current monitoring AC/DC multiscale	Single-phase minimum and maximum current monitoring AC/DC multiscale
CONTROL CIRCUIT			
Rated current	5 or 16A		0.02 - 0.05 - 0.25 - 1 - 5 - 16A
Rated frequency	50/60Hz ±5%		
Overload capacity	5 le for 1s 160A for 10ms Constant 16A	50mA - 1A inputs: 5 le for 1s 10le for 10ms Constant 2le	16A input: 5 le for 1s 160A for 10ms Constant 16A
Connection	Direct or by current transformer		
Adjustment	Tripping values 5...100% f.s.		
	Tripping time 0.1...30s		
	Inhibition time 1...60s		
	1...50%	3% fixed	
Resetting	Automatic or manual		
External input	Resetting or inhibition		—
Repeat accuracy	±1% with constant parameters		
AUXILIARY SUPPLY			
Auxiliary supply voltage Us	24...240VAC/DC		
Operating range	0.85...1.1Us		
Rated frequency	50/60Hz ±5%		
Power consumption (maximum)	3.2VA	7VA	
Power dissipation (maximum)	1.6W	1.7W	
RELAY OUTPUTS			
Number of relays	1	2	
Relay state	Normally energised / de-energised (selectable)		
Contacts arrangement	1 changeover contact SPDT each		
Rated operational voltage	250VAC		
Maximum switching voltage	400VAC		
IEC conventional free air thermal current Ith	8A		
UL/CSA and IEC/EN/BS 60947-5-1 designation	B300		
Electrical life (with rated load)	10 ⁵ cycles		
Mechanical life	30x10 ⁶ cycles		
Indications	1 green LED for power on/inhibition 1 red LED for tripping	1 green LED for power on/inhibition 2 red LEDs for max/min tripping	
CONNECTIONS			
Tightening torque maximum	0.8Nm (7lb.in; 7...9lb.in per UL/CSA)		
Conductor section min...max	0.2...4.0mm ² (24...12AWG; 18...12AWG per UL/CSA)		
INSULATION (input-output)			
IEC rated insulation voltage Ui	415VAC		
IEC rated impulse withstand voltage Uimp	4kV		
IEC power frequency withstand voltage	2.5kV		
AMBIENT CONDITIONS			
Operating temperature	-20...+60°C		
Storage temperature	-30...+80°C		
HOUSING			
Material	Self-extinguishing polyamide		

19 Monitoring relays

Technical characteristics
Pump protection

TYPE	PMA50	
DESCRIPTION	Single and three-phase pump protection (motor under-load and over-current control) monitoring for max AC current, min $\cos\varphi$, phase loss and incorrect phase sequence	
CURRENT AND $\cos\varphi$ CONTROL CIRCUIT		
Rated current I_e	5 or 16A	
Rated frequency	50/60Hz $\pm 5\%$	
Overload capacity	5 I_e for 1s 160A for 10ms Constant 16A	
Connection	Direct or by current transformer	
Adjustments	End-scale value	5 or 16A
	Tripping for MAX current	10...100 I_e
	Tripping for $\cos\varphi$	0.1...0.99 $\cos\varphi$ (Min)
	Tripping delay	0.1...10s
	Inhibition time	1...60s
	Automatic resetting delay	OFF...100min
External input	Consent for running/resetting	
Repeat accuracy	$\pm 1\%$ with constant parameters	
VOLTAGE CONTROL CIRCUIT		
Voltage measuring range (U_e)	80...660VAC	
Tripping time for phase loss	60ms	
AUXILIARY SUPPLY		
Auxiliary supply voltage U_s	220...240VAC	
	380...415VAC (maximum voltage for UL/CSA)	
	440...480VAC	
Operating range	0.85...1.1 U_s	
Frequency range	50/60Hz $\pm 5\%$	
Power consumption (maximum)	4.5VA	
Power dissipation (maximum)	2.3W	
RELAY OUTPUTS		
Number of relays	1	
Relay state	Normally energised, de-energises at tripping	
Contact arrangement	1 changeover contact SPDT	
Rated operational voltage	250VAC	
Maximum switching voltage	400VAC	
IEC conventional free air thermal current I_{th}	8A	
UL/CSA and IEC/EN/BS 60947-5-1 designation	B300	
Electrical life (With rated load)	10 ⁵ cycles	
Mechanical life	30x10 ⁶ cycles	
Indications	1 green LED for power on/inhibition 2 red LEDs for tripping	
CONNECTIONS		
Tightening torque maximum	0.8Nm (7lb.in)	
Conductor section min...max	0.2...4.0mm ² (24...12AWG; 18...12AWG per UL/CSA)	
INSULATION (input-output)		
IEC rated insulation voltage U_i	600VAC	
IEC rated impulse withstand voltage U_{imp}	6kV	
IEC power frequency withstand voltage	2.5kV	
AMBIENT CONDITIONS		
Operating temperature	-20...+60°C	
Storage temperature	-30...+80°C	
HOUSING		
Material	Self-extinguishing polyamide	

19 Monitoring relays

Technical characteristics
Frequency monitoring relays

TYPE	PMF20	
DESCRIPTION	Single-phase minimum and maximum frequency control	
FREQUENCY CONTROL CIRCUIT		
Rated frequency	50 or 60Hz selectable	
Operating frequency range	40...70Hz	
Adjustment	MAX tripping	101...110% operating frequency
	MIN tripping	90...99% operating frequency
	Resetting hysteresis	0.5%
	Inhibition time	0.1...20s
	Reset delay	0.1...20s
Resetting	Automatic	
Repeat accuracy	< ±0.1%	
AUXILIARY POWER SUPPLY		
Rated supply voltage U _e	220...240VAC	
	380...415VAC	
Operating range	0.85...1.1U _e	
Rated frequency	50/60Hz	
Power consumption (maximum)	10VA (220...240VAC); 17VA (380...415VAC)	
Power dissipation (maximum)	1.5W	
RELAY OUTPUTS		
Number of relays	1	
Relay state	Normally energised, de-energises at tripping ^❶	
Contact arrangement	1 changeover contact SPDT	
Rated operational voltage	250VAC	
Maximum switching voltage	400VAC	
IEC conventional free air thermal current I _{th}	8A	
UL/CSA and IEC/EN/BS 60947-5-1 designation	B300	
Electrical life (with rated load)	10 ⁹ cycles	
Mechanical life	30x10 ⁶ cycles	
Indications	1 green LED for power on/tripping 2 red LEDs for min-max tripping	
CONNECTIONS		
Tightening torque maximum	0.8Nm (7lb.in)	
Conductor section min-max	0.2...4.0mm ² (24...12AWG)	
INSULATION (input - output)		
IEC rated insulation voltage U _i	575VAC	
IEC rated impulse withstand voltage U _{imp}	6kV	
IEC power frequency withstand voltage	4kV	
AMBIENT CONDITIONS		
Operating temperature	-20...+60°C	
Storage temperature	-30...+80°C	
HOUSING		
Material	Self-extinguishing polyamide	

❶ Normally de-energised, energises at tripping with MAX function configured.

19 Monitoring relays

Technical characteristics
Interface protection system units

TYPE	PMVF20	PMVF20D048
AUXILIARY POWER SUPPLY		
Rated control supply voltage U_s	100...400VAC/110...250VDC	12...48VDC
Operating limits	90...440VAC/93.5...300VDC	9...70VDC
Frequency	45...55Hz	—
Power consumption max	3.9VA	2.5W
Power dissipation max	3.4W	2.5W
Micro-breaking immunity	≤ 50 ms at 110VAC ; ≤ 200 ms at 230VAC	≤ 15 ms at 12VDC; ≤ 30 ms at 24VDC; ≤ 70 ms at 48VDC
Overload category	III	III
VOLTAGE INPUTS		
Maximum rated operating voltage	400VAC L-L; 230VAC L-N 50Hz	
Measuring range	20...480VAC L-L; 10...276VAC L-N	
Frequency range	45...55Hz	
Overload category	IV	
CURRENT INPUTS (OPTIONAL)		
Rated operational current I_e	1A or 5A in AC programmable	
Measuring range	For 1A scale: 0.01...1.2A; for 5A scale: 0.01...6A	
Type of input	Shunts powered by external current transformer (low voltage) 5A max.	
Type of measurement	RMS	
Overload capacity	$\pm 20\%$ I_e	
Overload peak	50A for 1 second	
Burden (per phase)	≤ 0.6 W	
RELAY OUTPUTS		
Number of outputs	2	
Type of output	1 changeover contact/SPDT each	
Rated operating voltage	250VAC	
UL/CSA and IEC/EN/BS 60947-5-1 designation	5A 250VAC AC1 /B300 ; 5A 30VDC	
Overload category	III	
DIGITAL INPUTS		
Number and type of inputs	4 negative (NPN)	
Input voltage	24VDC isolated	
Input current	7mA	
SUPPLY/VOLTAGE MEASURING CIRCUIT CONNECTIONS		
Type of terminals	Screw - removable	
Conductor section (min...max)	0.2...2.5mm ² (24...12AWG)	
Tightening torque	0.5Nm (4.5lb.in)	
CURRENT MEASURING CIRCUIT CONNECTIONS		
Type of terminals	Screw - fixed	
Number of terminals	6 for external CT connections	
Conductor section (min...max)	0.2...4mm ² (26...10AWG)	
Tightening torque	0.8Nm (7lb.in)	
RELAY OUTPUT CONNECTIONS		
Type of terminals	Screw - removable	
Conductor section (min...max)	0.2...2.5 mm ² (24...12AWG)	
Tightening torque	0.5Nm (4.5lb.in)	
INPUT CONNECTIONS – Input terminals		
Type of terminals	Screw - removable	
Conductor section (min...max)	0.2...1.5 mm ² (28...14AWG)	
Tightening torque	0.18Nm (1.7lb.in)	
INPUT CONNECTIONS – COM and auxiliary voltage terminals		
Type of terminals	Screw - removable	
Conductor section (min...max)	0.2...2.5 mm ² (24...12AWG)	
Tightening torque	0.5Nm (4.5lb.in)	
HOUSING		
Material	Polyamide	
Version	Flush mount 96x96mm / 3.78x3.78"	

19 Monitoring relays

Technical characteristics
Interface protection system units

TYPE	PMVF51 - PMVF60 - PMVF70 - PMVF80
AUXILIARY POWER SUPPLY	
Rated control supply voltage U_s	100...240VAC/110...250VDC
Operating limits	85...264VAC/93.5...300VDC
Frequency	45...55Hz
Power consumption	AC supply 4.6VA at 110VAC; 12.5VA at 230VAC DC supply 23mA at 110VDC; 11mA 250VDC
Power dissipation	AC supply 2.5W at 110VAC; 2.7W at 230VAC DC supply 2.3W at 110VDC; 2.5W at 250VDC
Micro-breaking immunity	≤ 50 ms at 100VDC; ≤ 200 ms at 240VDC
Overload category	II
VOLTAGE INPUTS	
Maximum rated operating voltage	400VAC L-L; 230VAC L-N 50Hz
Measuring range	20...480VAC L-L; 10...276VAC L-N
Frequency range	45...55Hz
Overload category	IV
CURRENT INPUTS (OPTIONAL)	
Rated operational current I_e	1A or 5A in AC programmable
Measuring range	For 1A scale: 0.01...1.2A; for 5A scale: 0.01...6A
Type of measurement	RMS
Overload capacity	$\pm 20\%$ I_e
Overload peak	50A for 1 second
Burden (per phase)	≤ 0.6 W
RELAY OUTPUTS	
Number of outputs	2 ^①
Type of output	1 changeover contact/SPDT each
Rated operating voltage	250VAC
UL/CSA and IEC/EN/BS 60947-5-1 designation	For NO contact: 5A 250VAC AC1/C300; 5A 30VDC For NC contact: 2A 250VAC AC1 / C300; 2A 30VDC
Overload category	II
DIGITAL INPUTS	
Number and type of inputs	4 positive (PNP)
Input voltage	24VDC isolated
Input current	7mA
SUPPLY/VOLTAGE MEASURING CIRCUIT CONNECTIONS	
Type of terminals	Screw - removable
Conductor section (min...max)	0.2...4mm ² (24...12AWG)
Tightening torque	0.8Nm (4.5lb.in)
CURRENT MEASURING CIRCUIT CONNECTIONS	
Type of terminals	Screw - fixed
Number of terminals	6 for external CT connections
Conductor section (min...max)	0.2...2.5mm ² (24...12AWG)
Tightening torque	0.44Nm (4lb.in)
RELAY OUTPUT CONNECTIONS	
Type of terminals	Screw - removable
Conductor section (min...max)	0.2...2.5 mm ² (24...12AWG)
Tightening torque	0.44Nm (4lb.in)
INPUT CONNECTIONS – Input terminals	
Type of terminals	Screw - removable
Conductor section (min...max)	0.2...2.5 mm ² (24...12AWG)
Tightening torque	0.5Nm (4.5lb.in)
HOUSING	
Material	Polyamide
Version	Modular 6U

① Single insulation between the two outputs. Both outputs must use the same voltage group.

19 Monitoring relays

Technical characteristics
Interface protection system units

TYPE	PMVF30	PMVF30D048
AUXILIARY POWER SUPPLY		
Rated control supply voltage U_s	100...400VAC / 110...250VDC	
Operating limits	90...440VAC / 93,5...300VDC	
Frequency	45...55Hz	
Power consumption max	3.9VA	2.9W
Power dissipation max	3.4W	2.9W
Micro-breaking immunity	$\leq 30\text{ms}$ a 110VAC; $\leq 140\text{ms}$ a 230VAC	
Overload category	III	
VOLTAGE INPUTS		
Maximum rated operating voltage	50...500VAC (for voltages/frequency) / 50...150V (for residual voltage measurement)	
Measuring range (U_n)	400-150,000V (VT primary)	
Frequency range	45...55Hz	
Overload category	IV	
CURRENT INPUTS (OPTIONAL)		
Rated operational current I_e	1A or 5A in AC programmable	
Measuring range	For 1A scale: 0.01...1.2A; for 5A scale: 0.01...6A	
Type of input	Shunts powered by external current transformer (low voltage) 5A max.	
Type of measurement	RMS	
Overload capacity	$\pm 100\%$ I_e	
Overload peak	50A for 1 second	
Burden (per phase)	$\leq 0.3\text{W}$	
RELAY OUTPUTS		
Number of outputs	2	
Type of output	1 changeover contact/SPDT each	
Rated operating voltage	250VAC	
UL/CSA and IEC/EN/BS 60947-5-1 designation	5A 250VAC AC1 /B300; 5A 30VDC	
Overload category	III	
DIGITAL INPUTS		
Number and type of inputs	4 negative (NPN)	
Input voltage	24VDC isolated	
Input current	7mA	
SUPPLY/VOLTAGE MEASURING CIRCUIT CONNECTIONS		
Type of terminals	Screw - removable	
Number of terminals	2 for power supply; 5 for voltage control	
Conductor section (min...max)	0.2...2.5mm ² (24...12AWG)	
Tightening torque	0.5Nm (4.5lb.in)	
CURRENT MEASURING CIRCUIT CONNECTIONS		
Type of terminal	Screw - fixed	
Number of terminals	6 for external CT connections	
Conductor section (min...max)	0.2...4mm ² (26...10AWG)	
Tightening torque	0.8Nm (7lb.in)	
RELAY OUTPUT CONNECTIONS		
Type and (number) of terminals	Screw - removable (3)	
Conductor section (min...max)	0.2...2.5 mm ² (24...12AWG)	
Tightening torque	0.5Nm (4.5lb.in)	
INPUT CONNECTIONS – Input terminals		
Type and (number) of terminals	Screw - removable (4)	
Conductor section (min...max)	0.2...1.5 mm ² (28...14AWG)	
Tightening torque	0.18Nm (1.7lb.in)	
INPUT CONNECTIONS – COM and auxiliary voltage terminals		
Type and (number) of terminals	Screw - removable (3)	
Conductor section (min...max)	0.2...2.5 mm ² (24...12AWG)	
Tightening torque	0.5Nm (4.5lb.in)	
HOUSING		
Material	Polyamide	
Version	Flush mount 96x96mm / 3.78x3.78"	