

# Condensate Pumps

MARS SERIES **217**



21784

## MARS Low Profile 22' Pump

### Features:

- Low Profile Pump
- Compact Design
- Integrated Safety Switch
- Quick Service Check Valve
- Drip Proof Housing
- Class Leading Performance

MARS NO.	DESCRIPTION
21784	115 V, 60 Hz, Low Profile 22' Lift, 3/8 Check Valve, Safety Switch
21785	230 V, 60 Hz, Low Profile 22' Lift, 3/8 Check Valve, Safety Switch



21786

## MARS 16' Lift Pump

### Features:

- 16' Lift Pump
- Whisper Quiet
- ½ Gal Reservoir
- Rubber Isolation Feet
- Quick Service Check Valve
- Class Leading Performance

MARS NO.	DESCRIPTION
21786	115 V, 60 Hz, 16' Lift 3/8 Check Valve, Safety Switch, Medium Reservoir

MARS NO.	DIMENSIONS		
	LENGTH	WIDTH	HEIGHT
21784	10.25	5.04	5.28
21785	10.25	5.04	5.28
21786	10.25	5.125	6.375

## Check Valve Replacement

MARS NO.	DESCRIPTION
21787	Check Valve Replacement Kit



21780

## MARS Condensate Pump - 24 Foot Lift

MARS new line of medium condensate pumps are designed to outperform the competition while providing quiet operation and reliability.

The MARS pump design couples industry leading performance with the installation flexibility and features you need to get the job done.

The quick release silicone check valve allows for quick and efficient servicing without the need to remove the condensate line. The integrated safety switch can be wired for equipment shut down or directly to a high level alarm.

### Features:

- 24 foot lift
- 125 GPH
- 0.5 gal Reservoir
- Patent Pending, Quick Release Check Valve
- Field serviceable "Duck Bill" Check Valve
- Rubber Isolation Feet
- Drip Proof Housing Design
- Solid Float
- Integrated Safety Switch 250 volt and Float Switches
- ABS and Stainless Steel construction

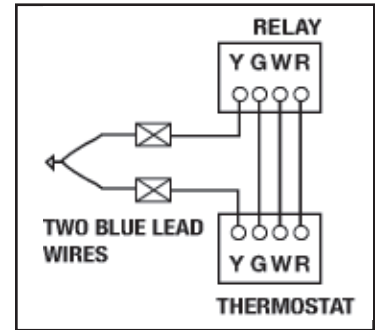

MARS NO.	DESCRIPTION
21780	115 V, 60 Hz, 0.91 Amps, 71 Watts 6' Cord, 3/8" Check Valve, Safety Switch Medium Reservoir
21781	115 V, 60 Hz, 0.91 Amps, 71 Watts 6' Cord, 3/8" Check Valve, Safety Switch 20' Tubing, Medium Reservoir
21782	230 V, 60 Hz, 0.6 Amps, 75 Watts 6' Cord, 3/8" Check Valve, Safety Switch Medium Reservoir
21783	230 V, 60 Hz, 0.6 Amps, 75 Watts 6' Cord, 3/8" Check Valve, Safety Switch 20' Tubing, Medium Reservoir

## Gallons Per Hour Pump Performance Comparison Chart

FOOT LIFT	1	5	10	15	20	24
MARS	125	98	74	70	43	7
Comp. 1	84	75	60	42	10	0
Comp. 2	117	98	70	58	11	0
Comp. 3	105	95	73	36	0	0

## Specifications

MODEL NO.	Performance - Gallons per hour @ height in feet					
	1	5	10	15	20	24
21780	125	98	74	70	43	7
21781	125	98	74	70	43	7
21782	139	119	70	50	28	7
21783	139	119	70	50	28	7

## Condensate Pump vs. Competition

FEATURE	MARS	COMP. 1	COMP. 2	COMP. 3
24 ft. Lift	●			
Motor Corrosion Protection	●			
Drip Proof Motor Housing	●	●		●
Drip Proof Motor & Switches	●			
Vibration Absorbing Rubber Feet	●	●	●	
Side Mount	●	●	●	●
Quick Release Check Valve	●	●		
Internal Safety Switch	●		●	
Solid Float	●	●		●

MODEL NO.	DIMENSIONS		
	Length	Width	Height
21780	10.25	5.125	6.375
21781	10.25	5.125	6.375
21782	10.25	5.125	6.375
21783	10.25	5.125	6.375

Dimensions in inches