

PRODUCT INFORMATION PACKET

Model No: 056T17F5327

Catalog No: G387

3 HP General Purpose Motor, 3 phase, 1800 RPM, 230/460 V, 56H Frame, TEFC
Three Phase TEFC Motors



Nameplate Specifications

Output HP	3 Hp	Output KW	2.2 kW
Frequency	60 Hz	Voltage	230/460 V
Current	8.6/4.3 A	Speed	1725 rpm
Service Factor	1	Phase	3
Efficiency	84 %	Power Factor	81
Duty	Continuous	Insulation Class	B
Design Code	B	KVA Code	K
Frame	56H	Enclosure	Totally Enclosed Fan Cooled
Thermal Protection	No	Ambient Temperature	40 °C
Drive End Bearing Size	6205	Opp Drive End Bearing Size	6203
UL	Recognized	CSA	Y
CE	Y	IP Code	43

Technical Specifications

Electrical Type	Squirrel Cage Induction Run	Starting Method	Across The Line
Poles	4	Rotation	Reversible
Resistance Main	1.54 Ohms	Mounting	Rigid Base
Motor Orientation	Horizontal	Drive End Bearing	Ball
Opp Drive End Bearing	Ball	Frame Material	Rolled Steel
Shaft Type	Single Special Extension	Overall Length	14.82 in
Frame Length	9.56 in	Shaft Diameter	0.625 in
Shaft Extension	1.88 in	Assembly/Box Mounting	F1 ONLY

This is an uncontrolled document once printed or downloaded and is subject to change without notice. Date Created:01/11/2019

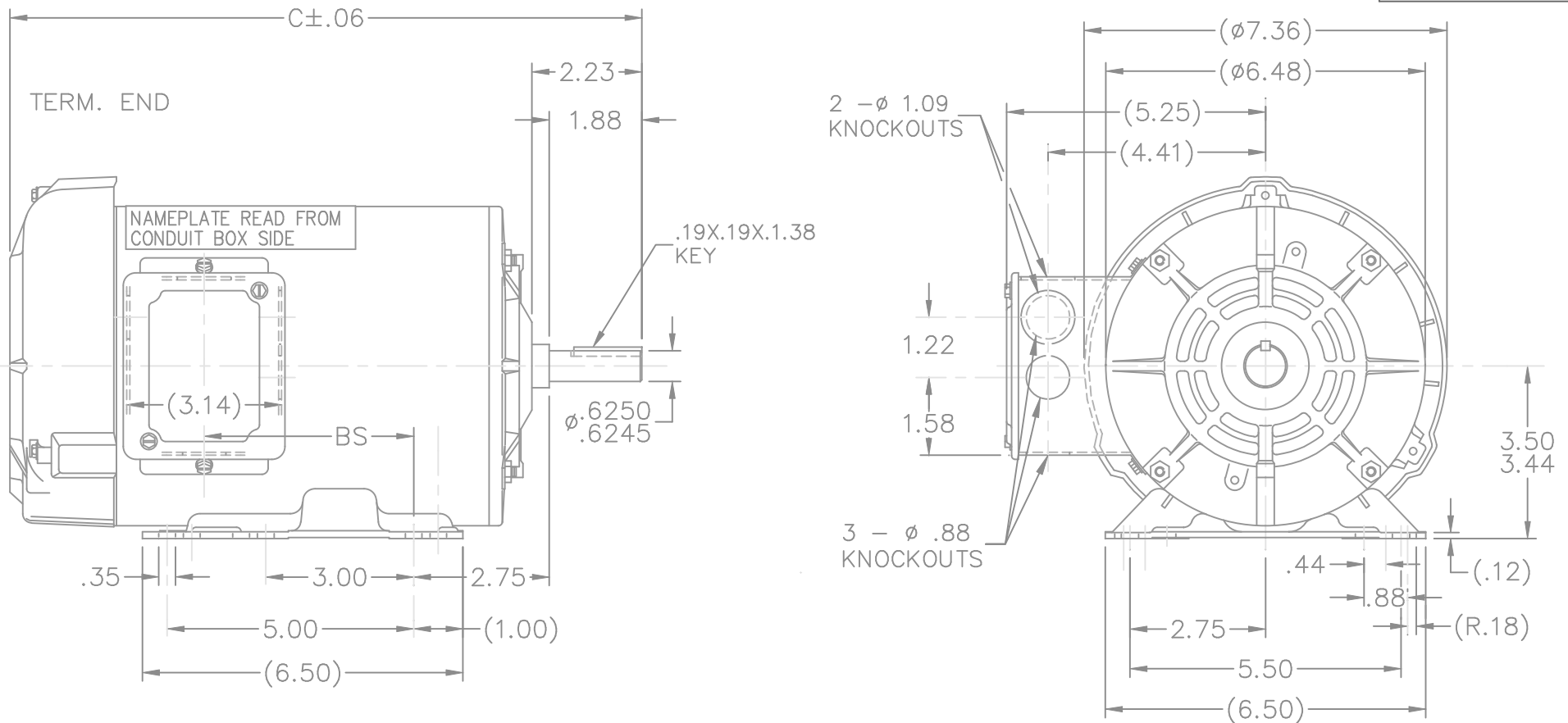

DASH	FR.	C	BS	DASH	FR.	C	BS
				806	56-80	13.52	4.75
				856	56-85	13.82	5.25
				956	56-85	14.82	6.25

NOTE:
CONDUIT BOX CAN BE ROTATED IN 180° STEPS.

				TOLERANCES UNLESS SPECIFIED		MARATHON ELECTRIC	DRAWN DA 02-24-1993						
				DEC.	INCHES		CHK	ML	02-24-1993				
				.X	±.1	TITLE OUTLINE 56 FR. - BB - 3Ø - TEFC	APPD	GK	02-24-1993	SCALE	5=16		
5	REDRAWN IN AUTOCAD	TAT	06-29-2004	ML	.XXX		±.005	REF					
4	REDRAWN ON CADD - 2.23 WAS 2.32 CN 15348	DA	02-25-1993		.XXXX	±.0005	FMF						
NO.	REVISION	BY & DATE	CHK	ANG	±7'30"		FINISH	PREV					
THIS DRAWING IN DESIGN AND DETAIL IS OUR PROPERTY AND MUST NOT BE USED EXCEPT IN CONNECTION WITH OUR WORK ALL RIGHTS OF DESIGN AND INVENTION ARE RESERVED THIS IS AN ELECTRONICALLY GENERATED DOCUMENT - DO NOT SCALE THIS PRINT				RFP			CAD FILE	100124	SIZE	DRAWING NO.	PAGE	OF	REV.
				DIST	WP			A	100124			5	

EE7308

THREE PHASE
DUAL VOLTAGE MOTOR



VIEW OF TERMINAL END

REF.
WINDING DIAGRAM

T8Y, T2Y, T2BL, T4BX, T2EC, T2G
T6BZ, T2B, T6BL, T4AV, T6B, T4B

OPTIONAL CORD
CONNECTION

L1 — WHITE
L2 — RED
L3 — BLACK

NO.	REVISION	BY & DATE	CHK	ANG	TOLERANCES UNLESS SPECIFIED		FINISH	DRAWN RM 11/20/1990				
					DEC.	INCHES						
5	CHG TO REGAL LOGO	SL 09/10/2015	AB					CHK ML 11/21/1990				
4	REVISED IEC NOTATIONS	MSG 11/15/2011	CMN	.X	±.1			APPD SAS 04/24/2003				
3	ADDED IEC NOTATIONS... (U1), (V1) ETC. MU95194	MSG 5/10/2010	MJS	.XX	±.02		TITLE CONNECTION DIAGRAM	SCALE 1=1				
2	ADDED THE OPTIONAL CORD CONNECTION MU46318	RDH 04/24/2003	DRS	.XXX	±.005		3Ø - DUAL VOLTAGE MOTOR	REF				
1	REDRAWN	RM 11/20/1990		.XXXX	±.0005		MAT'L.	FMF				
					±7'30"			PREV				
THIS DRAWING IN DESIGN AND DETAIL IS OUR PROPERTY AND MUST NOT BE USED EXCEPT IN CONNECTION WITH OUR WORK ALL RIGHTS OF DESIGN AND INVENTION ARE RESERVED THIS IS AN ELECTRONICALLY GENERATED DOCUMENT - DO NOT SCALE THIS PRINT							RFP	CAD FILE ee7308	SIZE A	DRAWING NO. EE7308	PAGE OF 5	REV. 5
							DIST WP					



Regal Beloit America, Inc.