

STANDARD AC INPUT MODULES

Features

- > Rugged construction
- > High noise rejection and transient-free *clean* switching
- > 4000 volts of optical isolation between the field inputs and the logic output of the circuit (transient)

DESCRIPTION

AC input modules are used for sensing ON/OFF alternating current (AC) voltage levels. All AC input modules are designed with filtering on the input and a hysteresis amplifier for high noise rejection and transient-free *clean* switching.

Each module provides up to 4000 volts (transient) of optical isolation between the field inputs and the logic output of the circuit.

Typical uses and applications include sensing the presence or absence of voltage or sensing contact closures from sources such as:

- Proximity switches
- Limit switches
- Float switches
- Selector switches
- Push buttons
- Toggle switches
- Thermostats



IAC5 Module

Part Numbers

Part	Description
IDC5*	DC Input 10–32 VDC, 5 VDC Logic
IDC5G*	DC Input 35–60 VDC, 5 VDC Logic
IAC5	AC Input 90–140 VAC, 5 VDC Logic
IAC5A	AC Input 180–280 VAC, 5 VDC Logic
IDC15*	DC Input 10–32 VDC, 15 VDC Logic
IAC15	AC Input 90–140 VAC, 15 VDC Logic
IAC15A*	AC Input 180–280 VAC, 15 VDC Logic
IDC24*	DC Input 10–32 VDC, 24 VDC Logic
IAC24	AC Input 90–140 VAC, 24 VDC Logic
IAC24A	AC Input 180–280 VAC, 24 VDC Logic

* These DC input modules can be used for AC input signals.
See table on page 2.



SPECIFICATIONS

General

Operating Ambient	-30 to 70 °C
Isolation, Input-to-Output (Transient)	4000 volts
Output Voltage Drop	0.4 volts @ 50 mA
Output Current	50 mA
Output Leakage With No Input	0.1 mA @ 30 VDC
Output Transistor	30 volts breakdown

AC Input Module Specifications

	Unit	IDC5	IDC5G	IDC15*	IDC24*	IAC5	IAC15*	IAC24*	IAC5A	IAC15A*	IAC24A*
Input Voltage Range	VAC	12–32	35–60	12–32	12–32	90–140	90–140	90–140	180–280	180–280	180–280
Input Current @ Max Line	mA	25	6	25	25	5	5	5	5.0	5.0	5.0
Turn-on Time	msec	5	10	5	5	20	20	20	20	20	20
Turn-off Time	msec	5	15	5	5	20	20	20	20	20	20
Input Allowed for No Output	mA, V	1, 3	0.7, 7	1, 3	1, 3	3, 45	3, 45	3, 45	1.7, 80	1.7, 80	1.7, 80
Output Supply Voltage-Nominal	VDC	5	5	15	24	5	15	24	5	15	24
Output Supply Voltage-Range	VDC	4.5–6	4.5–6	12–18	20–30	4.5–6	12–18	20–30	4.5–6	12–18	20–30
Output Supply Current @ Nominal Logic Voltage	mA	12	12	15	15	12	15	15	12	15	15
Input Resistance (R1 in schematic diagram)	Ohms	1.5k	10k	1.5k	1.5k	28k	28k	28k	70k	70k	70k
Control Resistance	Ohms	220	220	1k	2.2k	220	1k	2.2k	220	1k	2.2k

* Not for use with Opto 22 brains.

Dimensions

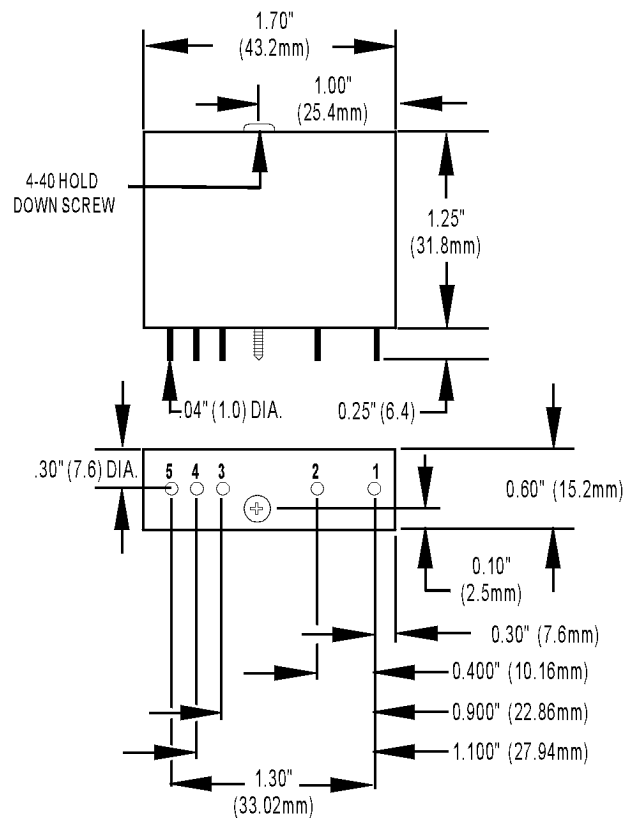

SCHEMATICS

AC Input Schematic

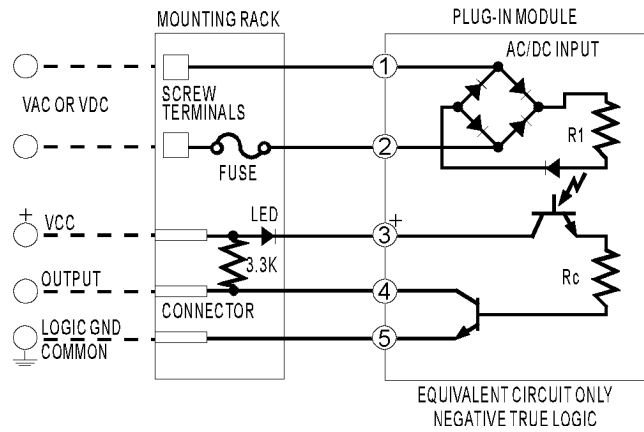

CONNECTIONS

AC Input Connection Diagram

