

AUTOMATIC WIRE STRIPPING AND FERRULE CRIMPING PRESS OPERATION MANUAL

© Panduit Corp. 2013

Original Instructions



**TO REDUCE THE RISK OF INJURY, USER
MUST READ INSTRUCTION MANUAL**

EU Website:
www.panduit.com/emea

EU Email:
emeatoolservicecenter@panduit.com





PANDUIT

www.panduit.com

Technical Support:
Tel: 888-506-5400, ext. 83255

Panduit Europe • EMEA Service Center
Almelo, Netherlands
Tel: +31-546-580-452 • Fax: +31-546-580-441

Contents

TECHNICAL DATA	1
Name Plate	1
PRECAUTIONS AND GENERAL GUIDELINES	2
Safety Warnings	2
 Electrical Safety Practices	3
 Personal Safety	4
 Power Tool Use And Care	5
 Service	6
Dedicated Usage	6
 Dangers	6
Places for Use	6
Safety Devices	7
Authorized user	7
Contents of Delivery	8
USAGE	9
Standard Components Overview	10
Standard Component Functions	11
SETUP	12
OPERATION	14
RETOOLING	17
FAULTS	18
TROUBLESHOOTING	19
SPARE PARTS	26

TECHNICAL DATA

Main power supply	230V / 50 Hz
Input Current	0,26A
Working range	#20 – #14 AWG (0,5 – 2,5 mm ²)
Ferrules	In Bands acc. To DIN 46228 Part 4
Press form	Trapezoid shaped
Cycle time	1,5 s
Control system	Microprocessor supported curve control
Counter	LCD Display
Retooling	Below 10 s
Sizes (Width x Length x Height)	6.5 x 12.6 x 11.0 in.
.....	165 x 320 x 279 mm
Weight	approx. 26 lb.
.....	approx. 12 kg.



NOTE: In the interest of higher quality and value, Panduit products are continually being improved and updated. Consequently, pictures may vary from the enclosed product.

Name Plate



<p>Panduit Corp. 18900 Panduit Drive, Tinley Park, IL 60487 USA</p> <p>CP-881 Serial Number Cross Section (working range) Manufactured Main Connection / Input Current</p> <p>Country of Origin CE Compliance Fuse Detail Website Address</p>	<div style="border: 1px solid black; padding: 10px;"> <p>PANDUIT CP-881/E</p> <p>S/N: XXXXX</p> <p>Cross Section: 0,5 – 2,5 mm² <i>Coupe transversale</i></p> <p>Mfg: XX-XX</p> <p>230 ~ / 50 Hz</p> <p>Input Current: 0,26A <i>Courant d'entrée</i></p> <p>Made in Germany <i>Fabriqué en Allemagne</i></p> <p> 2x T 0,63A</p> <p>www.panduit.com</p> </div> <div style="display: flex; justify-content: space-between; align-items: center; margin-top: 10px;"> <div style="writing-mode: vertical-rl; transform: rotate(180deg); font-size: small;">Q.C. XXXXXXXX-XX</div> <div style="text-align: center;"> </div> </div>
---	--

PRECAUTIONS AND GENERAL GUIDELINES



The basic condition for safe use and proper operation of the CP-881/E is the knowledge and attention to the safety information provided in this manual.

The following safety information must be observed by **all** persons who will work with the CP-881/E.



All rules and instructions for the work place must be observed, especially those for prevention of accidents.



	This symbol is used to call your attention to hazards or unsafe practices which could result in an injury or property damage. The signal word, defined below, indicates the severity of the hazard. The message after the signal word provides information for preventing or avoiding the hazard.	
	WARNING	Hazards which, if not avoided, COULD result in severe injury or death.
	CAUTION	Hazards or unsafe practices which, if not avoided, MAY result in injury or property damage.

Safety Warnings

	 WARNING
	<ul style="list-style-type: none"> • Read all safety warning and all instructions. Failure to follow the warnings and instructions may result in electric shock, fire and/or serious injury. • Save all warnings and instructions for future reference. • The term “power tool” in the warnings refers to your main-operated (corded) power tool.



	Panduit Corp. recommends the tool be used with all installed safety features. Customer assumes all liability for injury that could result from improper use of this tool and responsibility for all necessary training to ensure safe operation of this tool.
	• <i>FOR INSTALLATION AND USE BY TRAINED PERSONNEL ONLY.</i>
	• <i>IF ANY DAMAGE TO THE PRODUCT IS APPARENT OR SUSPECTED, DO NOT USE THE PRODUCT. REFER PRODUCT TO QUALIFIED SERVICE PERSONNEL.</i>
	• <i>FCC WARNING: CHANGES OR MODIFICATIONS TO THE PRODUCT COULD VOID THE USER’S AUTHORITY TO OPERATE THE PRODUCT.</i>
	• <i>USE RECOMMENDED ACCESSORIES. CONSULT THE OWNER’S MANUAL FOR RECOMMENDED ACCESSORIES. THE USE OF IMPROPER ACCESSORIES MAY CAUSE RISK OF INJURY TO PERSONS.</i>



	 WARNING
	<p>DO NOT OPERATE POWER TOOLS IN EXPLOSIVE ATMOSPHERES, SUCH AS IN THE PRESENCE OF FLAMMABLE LIQUIDS, GASES OR DUST.</p> <p><i>Power tools create sparks which may ignite the dust or fumes.</i></p> <p><i>Provide adequate ventilation around the product.</i></p>



		 WARNING
		<p>KEEP WORK AREA CLEAN AND WELL LIT. <i>Cluttered or dark areas invite accidents.</i></p> <p>KEEP CHILDREN AND BYSTANDERS AWAY. <i>All visitors should be kept a safe distance from work area.</i></p> <p>MAKE WORKSHOP KID PROOF with padlocks, master switches, or by removing starter keys.</p>

 **Electrical Safety Practices**





	<p><u>GROUNDING:</u> In the event of a malfunction or breakdown, grounding provides a path of least resistance for electric current which reduces the risk of electrical shock. This tool is equipped with an electric cord that includes an equipment-grounding conductor and a grounding plug. The plug must be inserted into a matching outlet that is properly installed and grounded in accordance with all local codes and ordinances.</p>
	<p>Improper connection of the equipment grounding conductor can result in a risk of electric shock. The conductor with insulation having an outer surface that is green with or without yellow stripes is the equipment-grounding conductor. If repair or replacement of the electric cord or plug is necessary, do not connect the equipment-grounding conductor to a live terminal.</p>
	<p>Check with a qualified electrician, or service personnel if the grounding instructions are not completely understood; or if in doubt as to whether the tool is properly grounded.</p>
	<p>DO NOT modify the plug provided. If it will not fit the outlet, have the proper outlet installed by a qualified electrician.</p>
	<p>Use only 3-wire extension cords that have 3-prong grounding plugs and 3-pole receptacles that accept the tool's plug. Replace a damaged or worn cord immediately.</p> <p>Avoid body contact with earthed or grounded surfaces, such as pipes, radiators, ranges and refrigerators. <i>There is an increased risk of electric shock if your body is earthed or grounded.</i></p> <p>DO NOT abuse the cord. Never use the cord for carrying, pulling or unplugging the power tool. Keep cord away from heat, oil, sharp edges or moving parts. Damaged or entangled cords increase the risk of electric shock.</p>

	 WARNING				
	<p>Power tool plugs must match the outlet. Never modify the plug in any way. Do not use any adapter plugs with earthed (grounded) power tools. <i>Unmodified plugs and matching outlets will reduce risk of electric shock.</i></p> <p>USE PROPER EXTENSION CORD. Make sure your extension cord is in good condition. When using an extension cord, be sure to use one heavy enough to carry the current your product will draw. An undersized cord will cause a drop in line voltage resulting in loss of power and overheating. Size the cord according to table below. If in doubt, use a heavier gauge.</p>				
	Volts	Total Length of Cord mm / (feet)			
	120	mm (25)	mm (50)	mm (100)	mm (150)
Minimum Wire Gauge of Cord	---	mm (18)	mm (16)	mm (16)	mm (14)

	 WARNING				
	<p>ONLY OPERATE THE CP-881/E A CLEAN, DRY, INDOOR ENVIRONMENT. DO NOT EXPOSE POWER TOOLS TO RAIN OR WET CONDITIONS. <i>Water entering a power tool will increase the risk of electric shock.</i></p>				

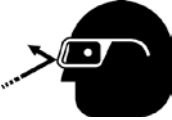
	 KEEP AWAY FROM LIVE CIRCUITS:				
	<ul style="list-style-type: none"> • Operating personnel must not remove covers. • Replacement of components and internal adjustments must be made by qualified maintenance personnel. • Disconnect power cable when replacing components. • Dangerous voltages may exist even with the power cable removed. • To avoid injuries, always disconnect power and discharge circuits by grounding before touching circuitry. • Input connection to the product must remain accessible as a disconnect device. • DO NOT work on the product; connect or disconnect cables during periods of lightning. • Provide wiring per national and local electrical codes. 				

 **Personal Safety**

	 WARNING				
<p>Use personal protective equipment. Safety glasses must be worn at all times by all persons operating or the CP-881/E.</p>					
	 WARNING				
<p>Hearing protection is recommended to be worn during operation of tool.</p>					

1. **STAY ALERT, watch what you are doing and use common sense when operating a power tool. Do not use a power tool while you are tired or under the influence of drugs, alcohol or medication.**
A moment of inattention while operating power tools may result in serious personal injury.

2. **KEEP GUARDS IN PLACE** and in working order.
These safety guards should be removed only by specialized and authorized technical persons who take care to adopt all security measures to avoid any risk of danger and injury.
3. **PREVENT UNINTENTIONAL STARTING.** Ensure the switch is in the off-position before connecting to power source and/or battery pack, picking up or carrying the tool.
Carrying power tools with your finger on the switch or energizing power tools that have the switch on invites accidents.
4. **NEVER LEAVE TOOL RUNNING UNATTENDED.**
TURN POWER OFF. Don't leave tool until it comes to a complete stop.
5. **Remove any adjusting key or wrench before turning the power tool on.**
A wrench or a key left attached to a rotating part of the power tool may result in personal injury.
6. **Do not overreach. Keep proper footing and balance at all times.**
This enables better control of the power tool in unexpected situations.
7. **NEVER STAND ON TOOL.**
Serious injury could occur if the tool is tipped or if the cutting tool is unintentionally contacted.
8. **Wear proper apparel. Do not wear loose clothing, gloves, neckties, rings, bracelets, or other jewelry which may get caught in moving parts. Nonslip footwear is recommended. Wear protective hair covering to contain long hair.**
9. **If devices are provided for the connection of dust extraction and collection facilities, ensure these are connected and properly used.**
Use of dust collection can reduce dust-related hazards.



Power Tool Use And Care

1. **Do not force the power tool. Use the correct power tool for your application.**
The correct power tool will do the job better and safer at the rate for which it was designed.
2. **Do not use the power tool if the switch does not turn it ON and OFF.**
Any power tool that cannot be controlled with the switch is dangerous and must be repaired.
3. **Disconnect the plug from the power source and/or the battery pack from the power tool before making any adjustments, changing accessories, or storing power tools.**
Such preventive safety measures reduce the risk of starting the power tool accidentally.
4. **Store idle power tools out of the reach of children and do not allow persons unfamiliar with the power tool or these instructions to operate the power tool.**
Power tools are dangerous in the hands of untrained users.
5. **Maintain power tools. Check for misalignment or binding of moving parts, breakage of parts and any other condition that may affect the power tool's operation. If damaged, have the power tool repaired before use.**
Many accidents are caused by poorly maintained power tools.
6. **Keep cutting tools sharp and clean.**
Properly maintained cutting tools with sharp cutting edges are less likely to bind and are easier to control.
7. **Use the power tool, accessories and tool bits, etc. in accordance with these instructions, taking into account the working conditions and the work to be performed.**
Use of the power tool for operations different from those intended could result in a hazardous situation.



Service

- **Have your power tool serviced by a qualified repair person using only identical replacement parts.**

Contact Panduit Tool Service at the following locations:

Panduit Tool Solutions Division (USA) 16530 163rd Street Lockport, IL 60441, USA Tél. : +1 888 506 5400, poste 83255	Panduit EMEA Service Center (EUR) EMEA Tool Service Center Bedrijvenpark Twente 360 7602 KL Almelo, Pays-Bas tél + 31 546 580 451
---	---

The information contained in this manual is based on our experience to date and is believed to be reliable. It is intended as a guide for use by persons having technical skill at their own discretion and risk. We do not guarantee favorable results or assume any liability in connection with its use. Dimensions contained herein are for reference purposes only. For specific dimensional requirements consult the factory. This publication is not to be taken as a license to operate under, or a recommendation to infringe any existing patents.

Dedicated Usage

- Use the CP-881/E only for automatic wire stripping and ferrule crimping.
- Continuously molded ferrules with cross-sections ranging from #20 – #14 AWG (0,5 – 2,5mm²) and a strip length of 5/16" (8 mm) must be used.
- Only the intended PVC insulated cables may be inserted into the funnel guide of the CP-881/E. Never insert solid metal parts or items, the stripping knives would be damaged.
- Third party reconstruction and changes of the CP-881/E beyond retooling are not allowed because of safety!



Dangers

- Use the CP-881/E only when the cover is closed.
- Before carrying out any work with the cover open (e.g. retooling, maintenance work), disconnect the CP-881/E from the main power supply
- Make sure that no strange objects are inside the case.

Places for Use

Avoid operation in the following areas:

- Damp or dusty places
- Places exposed to high or low temperatures, or direct sunlight
- Operating temperature range: 59°F to 95°F (15°C to 35°C)
- Condensation can form when moving from a cold to a warm place
- Open cover to evaporate any condensation before using the CP-881/E
- Do not spill any liquids over the CP-881/E
- Protect the CP-881/E from heavy vibrations and jolts

Safety Devices

- The CP-881/E can be switched OFF through:
 - The main switch (O OFF)
 - Pulling out the main plug
 - Sliding back the cover (by two micro switches)
 - The cover is built in for safety. It may not be changed, removed or by-passed by reconstructions. A label points to existing dangers.

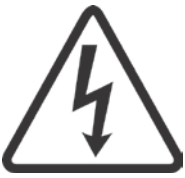

Before opening disconnect main power.

Vor Öffnen des Gehäuses Netzstecker ziehen.

Avant d'ouvrir l'appareil retirez la fichemâle.

Authorized user

- Only authorized and instructed users are allowed to work with the CP-881/E
- The user has a responsibility to other persons inside the CP-881/E work place

The customer must:

- Make the operation manual accessible to the user; and assure that the user has read and understood the manual.

Contents of Delivery

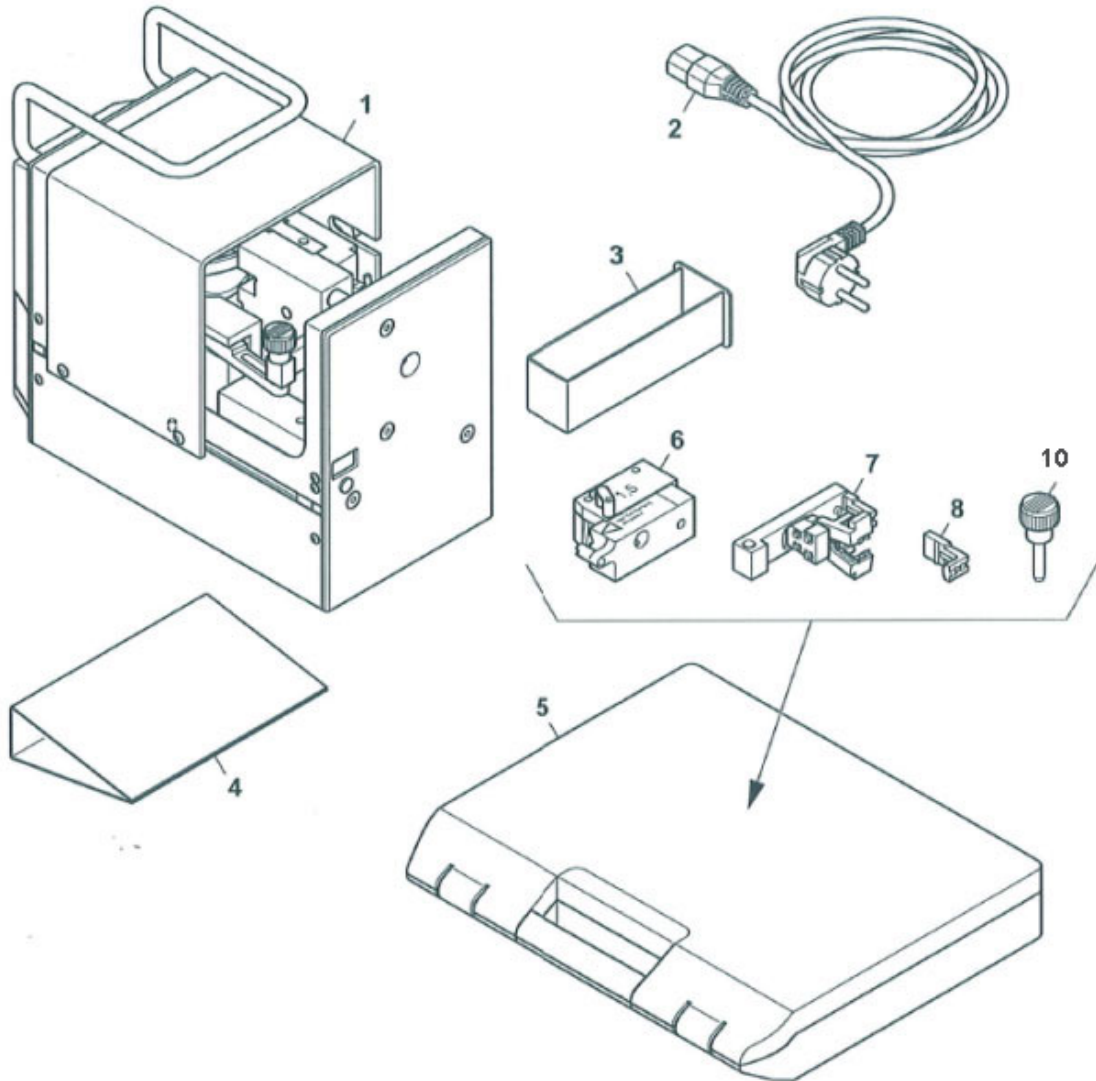

Diagram 1: Contents of Delivery

1. CP-881/E	1 piece	6. Ferrule Feeder #20-#14 AWG (0,5 to 2,5mm ²)	5 pieces
2. Main Cable	1 piece	7. Tool Insert for #20-#14 AWG (0,5 to 2,5mm ²)	5 pieces
3. Wire Insulation Scrap Container	1 piece	8. Locator (spare)	5 pieces
4. Operation Manual (English)	1 piece	9. Wire Guiding Tube (spare) <not shown>	5 pieces
5. Tool Kit	1 piece	10. Bolt, 6mm in diameter w/Lanyard	1 piece

NOTE: Parts 6, 7 and 8 have the same color code as ferrules, complying with DIN.

USAGE

The CP-881/E is for fully automatic stripping of flexible PVC insulated cables and subsequent pressing on of continuously molded insulated ferrules on reels.

It uses continuously molded ferrules complying with DIN 46228 Part 4, with cross-sections ranging from #20 – #14 AWG (0,5 – 2,5mm²), with a stripping length of 5/16" (8mm). Due to the short cycle times (1.5 s) and simple changing of cross-sections (below 10 s), the CP-881/E is not only suitable for use in workshops but also in complex cable production systems.

The following ferrules can be used by the CP-881/E:

Cross-section AWG (mm²)	Length In. / (mm)	DIN Color Code
20 (0,5)	5/16" (8)	White
18 (0,75)	5/16" (8)	Grey
18 (1,0)	5/16" (8)	Red
16 (1,5)	5/16" (8)	Black
14 (2,5)	5/16" (8)	Blue

Standard Components Overview

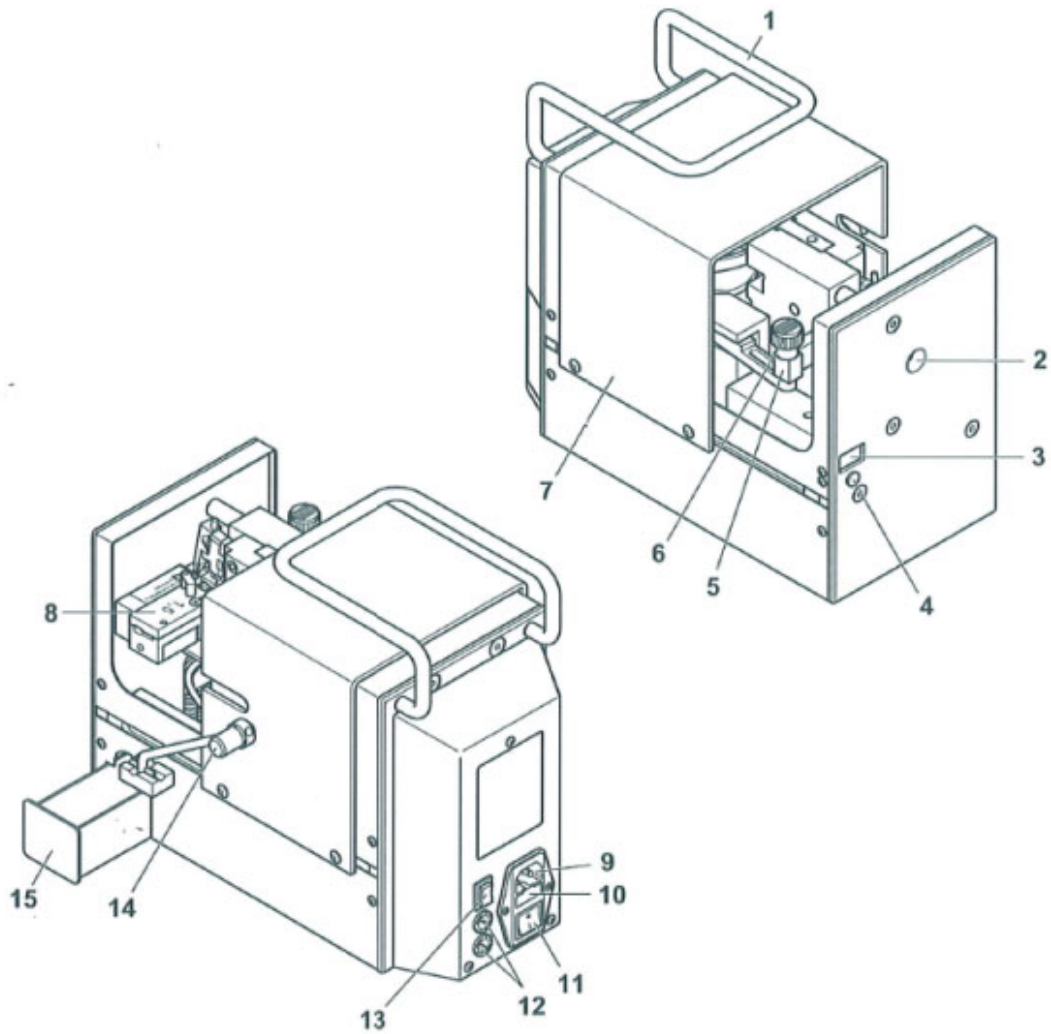

Diagram 2: Standard Components

1. Grip	9. Main connection
2. Funnel guide	10. Main fuses
3. Counter	11. Main switch
4. Reset button	12. Transformer fuses
5. Tool insert	13. Reverse button
6. Bolt with Lanyard	14. Ferrule dispenser holder
7. Cover	15. Container
8. Ferrule feeder	

Standard Component Functions

1. Grip
For transport of the CP-881/E
2. Funnel Guide
The cable to be processed is inserted into the CP-881/E through the funnel guide. Once it has been inserted, work commences automatically.
3. Counter (000000 to 999999)
The counter counts the number of end-sleeves used.
The CP-881/E performs a reset automatically to 0 at power-OFF.
4. Reset Button
This button resets the counter to 0.
5. Tool Insert (Color Coded)
Positions the ferrule and strips the cable.
The appropriate tool insert must be installed for every cross-section.
6. Bolt
Secures the tool insert (attached to CP-881/E by lanyard).
7. Cover
Protects the user from moving parts inside the CP-881/E.
The CP-881/E will only operate when the cover is properly closed.
8. Ferrule Feeder
The ferrule feeder positions the ferrules. The appropriate ferrule feeder must be installed for every cross-section.
9. Main Connection
The main cable must be connected to the input connector.
10. Main Fuses
Two 0,63 A/T/250 V fine wire fuses integrated into the main connection.
11. Main Switch
Switches the power supply to the CP-881/E ON (Position I) or OFF (Position O).
12. Transformer Fuses
One 4.0 A/T/250 V fine wire fuse for secondary device.
13. Reverse Button
Pressing this button puts the CP-881/E in the maintenance position.
Pressing again will put the CP-881/E in start position.
14. Ferrule Dispenser Holder
Holds the ferrule reel dispenser.
15. Container
The container collects the insulation scrap. It must be emptied regularly.

SETUP

1. Choose the installation site
 - The installation site of the CP-881/E must be level and horizontal.

NOTE: Observe the working conditions in Safety section, Places for Use

- , on Page 6

2. Prepare the dispenser
 - Open the dispenser and tear-off the strap at the edge (1).
 - Pull out the ferrule band (2) approximately 8" (20 cm).

Diagram 3: Prepare the dispenser

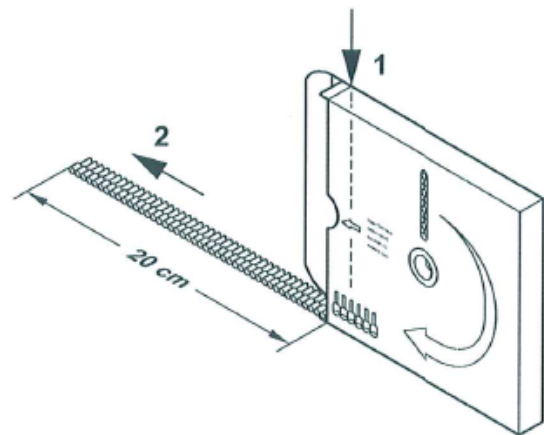

3. Prepare the ferrule feeder
 - Take ferrule feeder with proper cross-section from the tool kit.

NOTE: Observe the color code of the ferrule feeder

 - Insert the ferrules (1) in the guide sideways until the stop pin is reached.
 - Pull the pin (2) upwards, move the ferrules to the mark (3) and let the pin go.

Diagram 4: Prepare the ferrule feeder

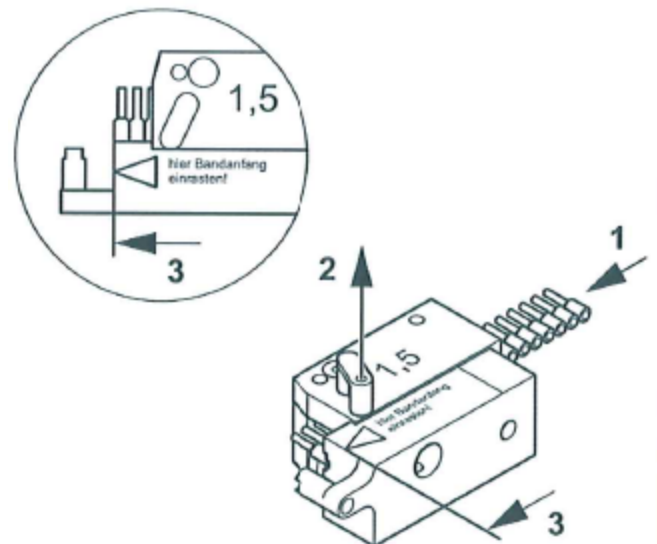

NOTE: Check that the pin has clicked properly into place.

4. Fit the ferrule feeder

NOTE: Verify that the tool insert is not installed yet.

- Slide the cover (1) back.
- Insert the ferrule feeder (2) sideways and place it on the bolts (3).

NOTE: Check that the ferrule feeder has clicked properly into place.

Diagram 5: Fit the ferrule feeder

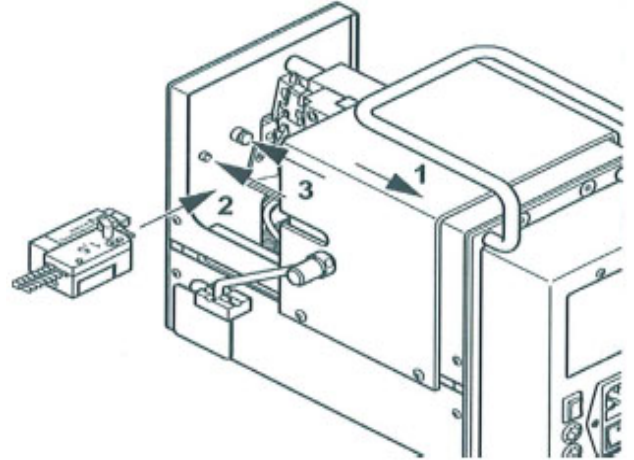

5. Mount the dispenser

- Mount the dispenser (1) on the holder.

NOTE: Check that the dispenser has clicked properly into place.

Diagram 6: Mount the dispenser

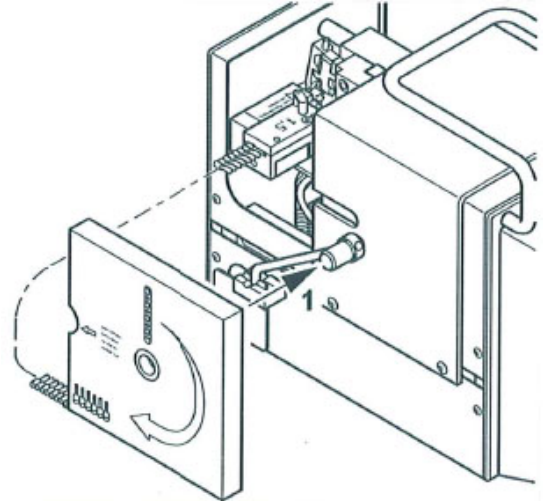

6. Mount the tool insert

- Take the tool insert with proper cross-section from the tool kit.

NOTE: Observe the color code of the tool insert.

- Mount the tool insert (1) sideways.
- Fit the bolt (2) into the hole until it stops.

Diagram 7: Mount the tool insert

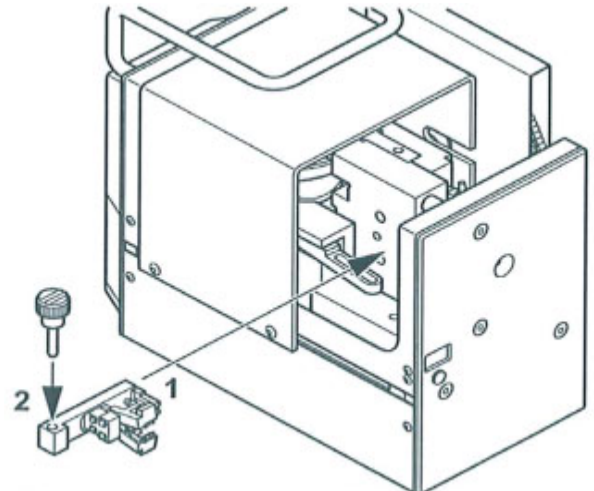

<p>7. Place into operation mode</p> <ul style="list-style-type: none"> ○ Put the dispenser (1) in operation mode. ○ Close the cover (2). <p>NOTE: Be sure that the ferrule band is fed properly.</p> <ul style="list-style-type: none"> ○ Connect the main cable with the appropriate connectors (3, 4) to the CP-881/E and the main power supply. <p>The CP-881/E is now ready for operation.</p>	<p style="text-align: center;">Diagram 8: Place into operation mode</p>
---	--

OPERATION

<p>1. Prepare the cable</p> <ul style="list-style-type: none"> ○ Before crimping, cable must be aligned as straight as possible. 	<p style="text-align: center;">Diagram 9: Prepare the cable</p>
<p>2. Cut the cable</p> <ul style="list-style-type: none"> ○ Cut the cable clean and straight. <p>NOTE: Poor cut (Diagram 11) frequently results in unsuccessful crimping.</p>	<p style="text-align: center;">Diagram 10: Cutting the cable</p> <p style="text-align: right;">Good cut</p>

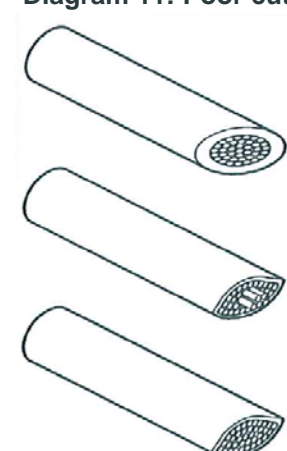
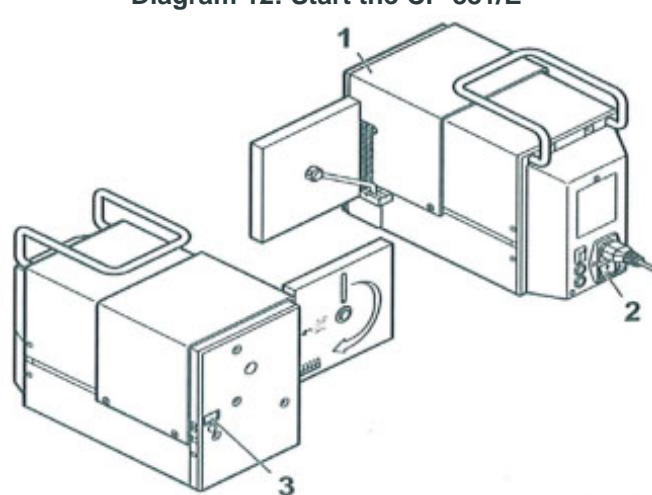
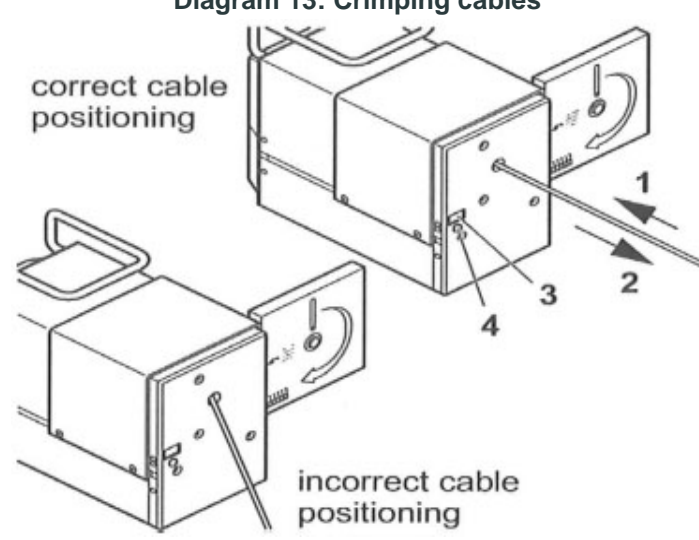
	<p>Diagram 11: Poor cut</p> 	<p>Surface inclined</p> <hr/> <p>Squashed cut, individual wires protrude</p> <hr/> <p>Squashed cut</p>
<p>3. Start the CP-881/E</p> <ul style="list-style-type: none"> ○ Check that the cover (1) is closed. ○ Turn on (Position I) the CP-881/E with the main switch (2). ○ Check that counter (3) is at 0. <p>NOTE: If the counter is not a 0, refer to chapter Faults.</p>	<p>Diagram 12: Start the CP-881/E</p> 	
<p>4. Crimping cables</p> <ul style="list-style-type: none"> ○ Insert the cable (1) straight into the funnel guide until it stops. ○ Crimping and stripping works automatically. ○ Pull out the cable (2) straight when the CP-881/E has stopped. <p>NOTE: Refer to chapter faults when operating faults or unsuccessful crimping occurs.</p> <ul style="list-style-type: none"> ○ Read counter (3) if required and set it to 0 with the reset button (4). 	<p>Diagram 13: Crimping cables</p> 	

5. Stop operation

- Read counter (1) if required.
- Turn OFF (Position O) the main switch (2) to the CP-881/E.

Diagram 14: Stop operation

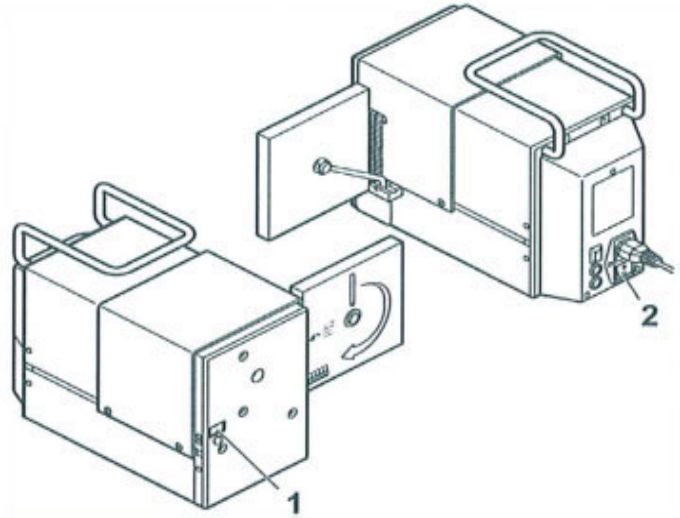

6. Daily maintenance



Disconnect the main power supply from the CP-881/E and open cover.

- Turn OFF (Position O) the main switch (1) to CP-881/E.
- Disconnect main cable (2).
- Slide the cover (3) back.
- Remove (4) insulation scraps inside the CP-881/E.
- Pull out the container (5).
- Dispose of insulation scraps and insert container.
- Close the cover (6).
- Connect main cable (7).
- **NO LUBRICATION REQUIRED!**

Diagram 15: Daily maintenance

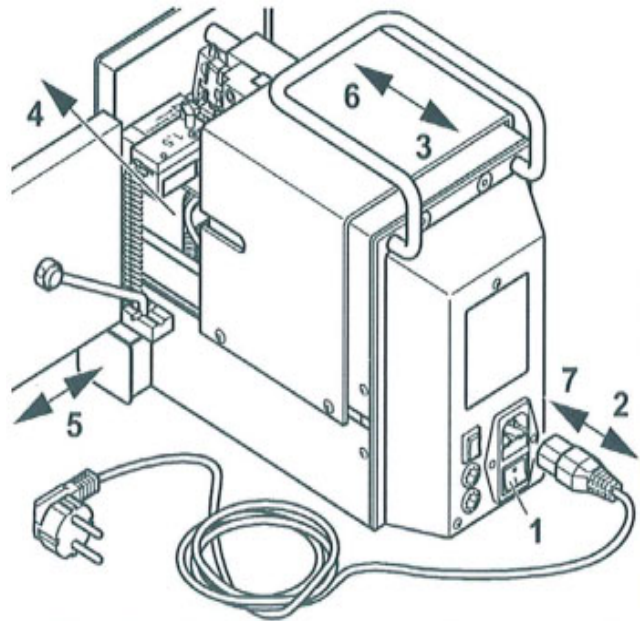

RETOOLING

1. Prepare the retooling



Disconnect the main power supply from the CP-881/E and open cover.

- Read counter if required.
- Turn OFF the CP-881/E with main switch (1).
- Disconnect main cable (2).
- Slide back the cover (3).
- Pull the pin (4) upwards and pull out the ferrules (5).
- Remove the dispenser (6) and roll up the remaining ferrules.
- Fold back the dispenser holder (7).

Diagram 16: Prepare the retooling

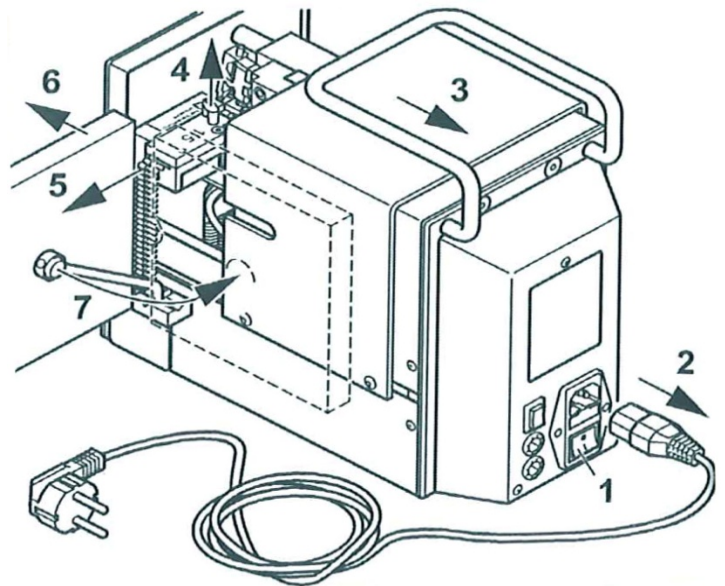

2. Remove the tool insert

- Pull out the bolt (1).
- The tool insert (2) must be removed sideways.
- Put the tool insert into the tool kit.
- Check crimp die for talcum powder build-up.
 - If powder build-up, clean with brush.

Diagram 17: Remove tool insert

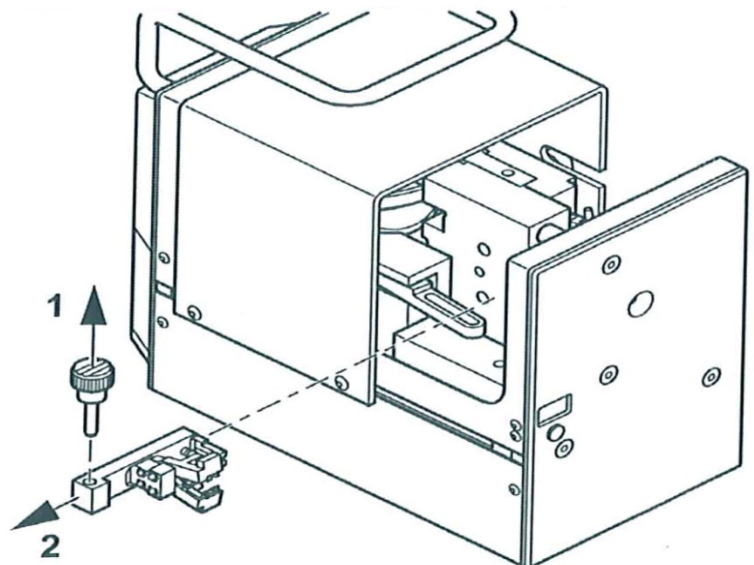

3. Remove the ferrule feeder

- Pull the ferrule feeder (1) towards the rear and remove it sideways (2).
- Put the ferrule feeder into the tool kit.

Continue as described with Step 2 to 7 in Chapter SETUP.

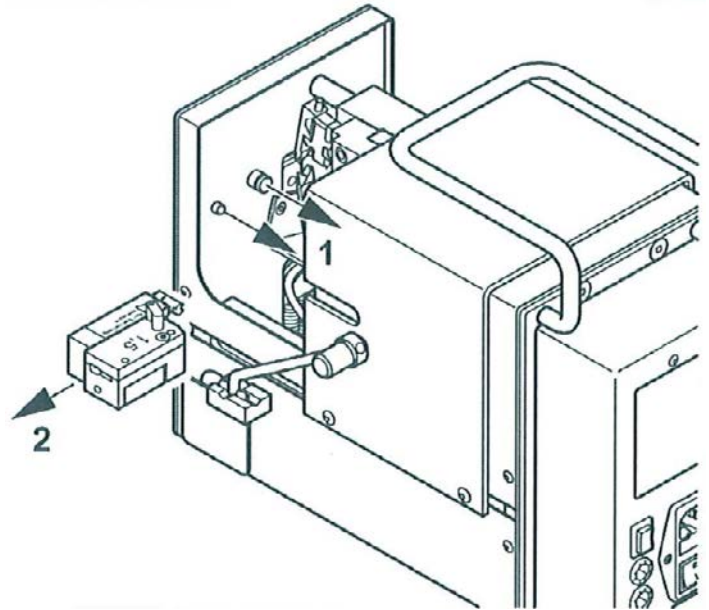
Diagram 18: Remove the ferrule feeder**FAULTS**

When operating faults occur, trouble-shooting depends on different fault conditions. After recognizing the fault condition, trouble-shooting can be carried out by the following points.

Fault Condition 1

Cable cannot be inserted.

Fault Condition 2

Crimping has not been completed.

Fault Condition 3

Crimping is completed.

Cable cannot be pulled out.

Fault Condition 4

Cable insulation is not completely removed.

Fault Condition 5

The ferrule is not separated from band.

Fault Condition 6

Counter respectively, CP-881/E does not work.

Fault Condition 7

The CP-881/E works tool slow, but counter works.

Fault Condition 8

Crimp stamp or crimp forging die is defective.

TROUBLESHOOTING

Fault Condition 1:

Cable cannot be inserted

- Cable can only be inserted in start position (front) and not in maintenance position (rear).
- Press the reverse button (1) to move the CP-881/E into start position.

Diagram 19: Move the CP-881/E into start position

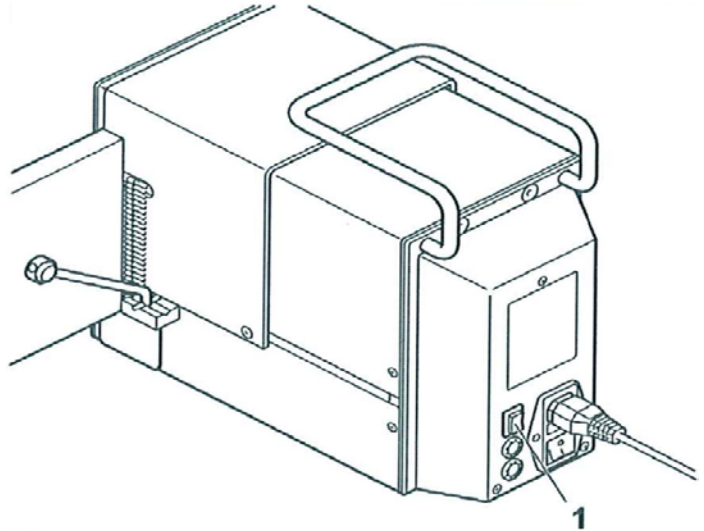

Fault Condition 2:

Crimping has not been completed.



Disconnect the main power supply from the CP-881/E and open cover.

1. Stop operation

- Read counter (1) if required.
- Turn OFF (Position O) the CP-881/E with main switch (2).
- Disconnect main cable (3).

Diagram 20: Stop operation

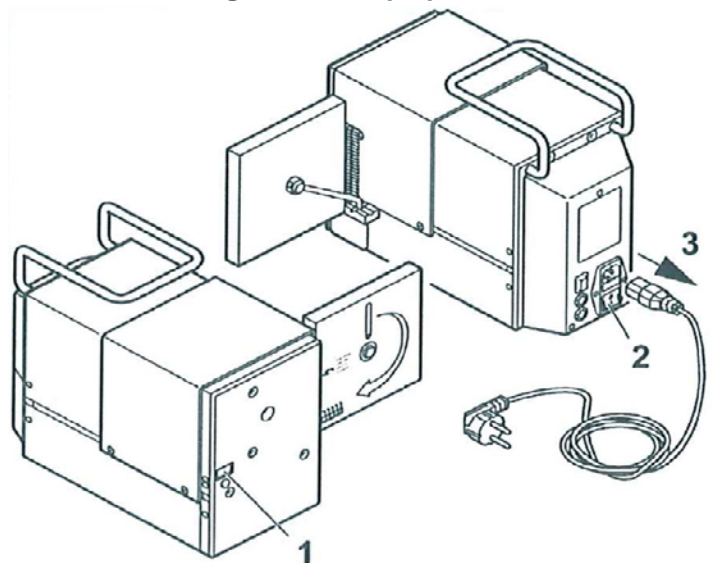

2. Remove the tool insert

- Slide back the cover (1).
- Pull out the bolt (2).
- Press lower stripping cutter (3) upwards and remove the tool insert (4) sideways.
- Remove ferrule (5).
- Bend cable aside (6).

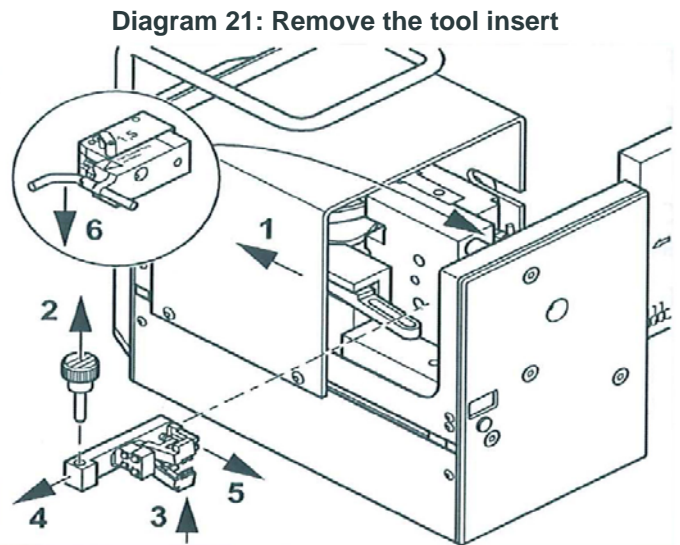
**3. Remove the cable**

- Pull the pin (1) upwards and pull out the ferrules (2).
- Close the cover (3).
- Connect main cable (4).
- Turn ON (Position I) the CP-881/E with the main switch (5).
- Press the reverse button (6) to move the CP-881/E into start position.
- Pull out the cable (7).

After mounting the tool insert and insertion of the ferrules, the CP-881/E is ready for operation.

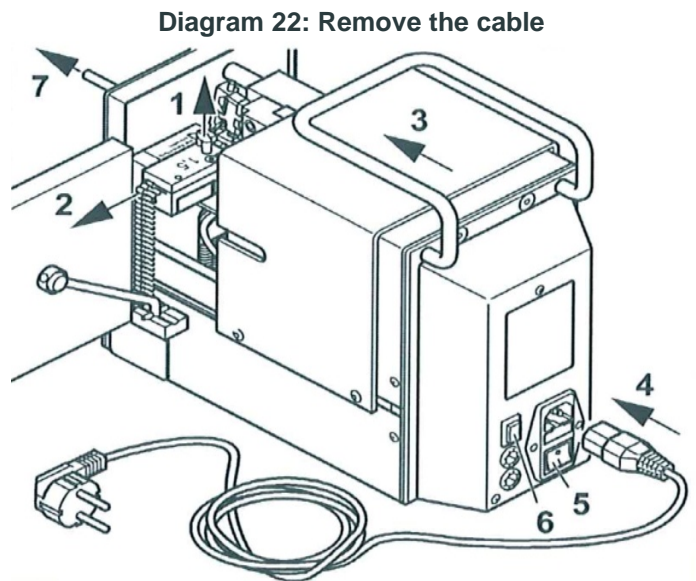

Fault Condition 3:

Crimping is completed. Cable cannot be pulled out



Disconnect the main Power supply from the CP-881/E and open cover.

1. Stop operation

- Read counter (1) if required.
- Press the reverse button (2) to move the CP-881/E into start position.
- Turn OFF (Position O) the CP-881/E with Main Switch (3).
- Disconnect main cable (4).

Diagram 23: Stop operation

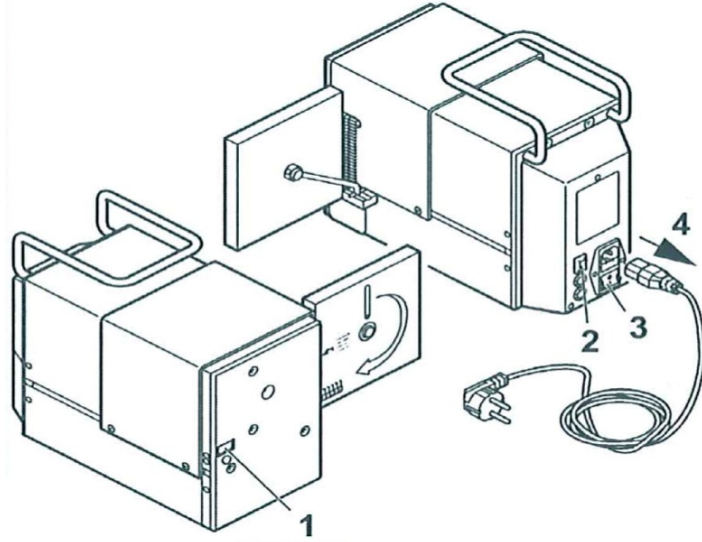

2. Remove the tool insert

- Slide back the cover (1).
- Pull out the bolt (2).
- Press lower stripping cutter (3) upwards and remove the tool insert (4) sideways.



If it is impossible to Remove the tool insert, then carry out Step 4; otherwise, carry on with Step 3.

- Remove ferrule (5).
- Bend cable aside (6).

Diagram 24: Remove the tool insert

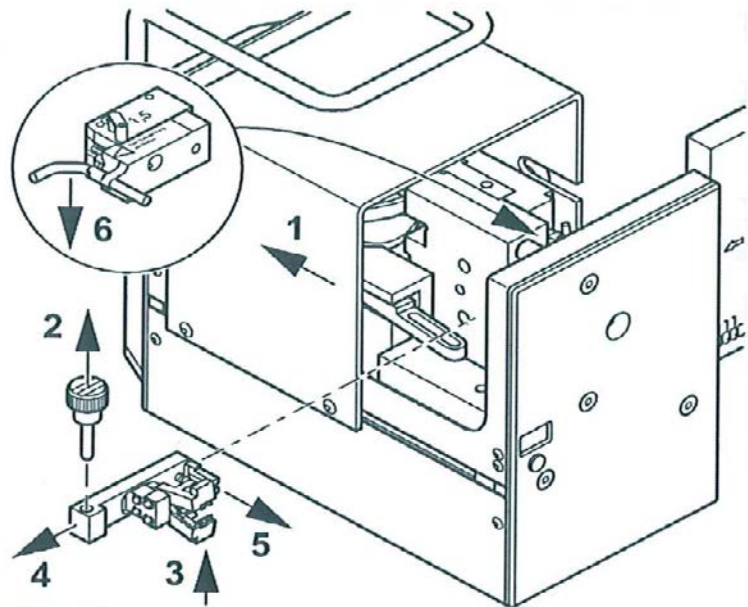

3. Remove the cable

- Pull the pin (1) upwards and pull out the ferrules (2).
- Close the cover (3).
- Connect main cable (4).
- Turn ON (Position I) the CP-881/E with the main switch (5).
- Press the reverse button (6) to move the CP-881/E into start position.
- Pull out the cable (7).

After mounting the tool insert and insertion of the ferrules, the CP-881/E is ready for operation.

Diagram 25: Remove the cable

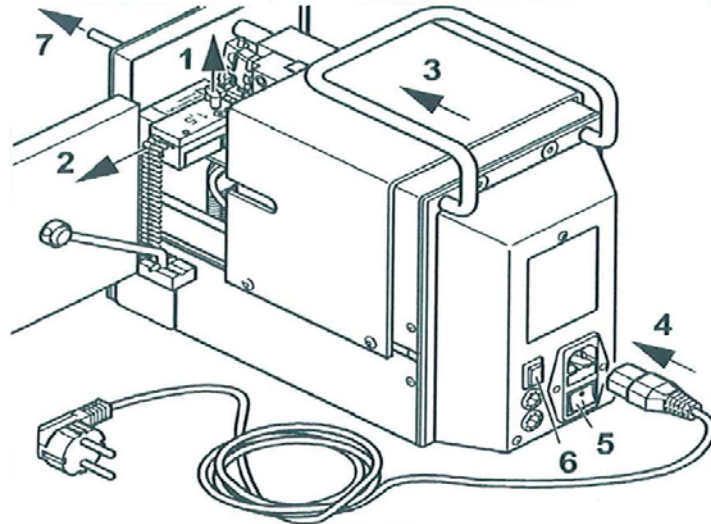

4. Remove the cable

- Press the reverse button (2) and pull the cable (1) at the same time, the CP-881/E moves into start position.
- Pull out the cable (3).
- Remove the tool insert (4).
- Remove ferrule (5).

After mounting the tool insert, the CP-881/E is ready for operation.

Diagram 26: Remove the cable

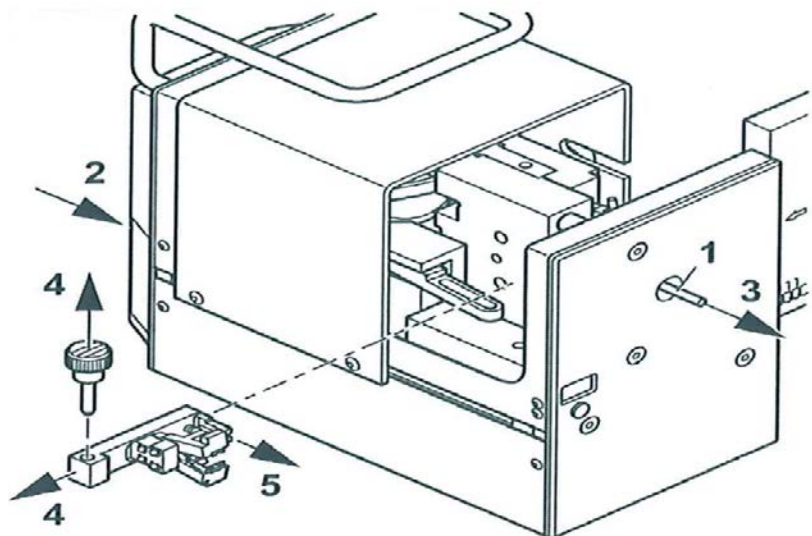

Fault Condition 4:

Cable insulation is not completely removed.



Disconnect the main power supply from the CP-881/E and open cover.

1. Check the cross-section information

If stripping is faulty, check whether the selected cable cross-section corresponds to the cross-section size of the tool insert and the ferrule feeder block. The tool inserts must be adapted to the cable cross-section if the CP-881/E has not been properly tooled. The cross-section of the cable must also be checked.

2. Check the stripping cutter

After checking the cross-section size remove the tool insert (see Chapter RETOOLING) and check the stripping cutters (1).

Replace the stripping cutters of the tool insert if they are worn or damaged.

Remove the allen screw (2) at the bottom and insert new stripping cutters with the same cross-section. The corresponding article number is stated in Chapter SPARE PARTS.

Diagram 27: Check the stripping cutter

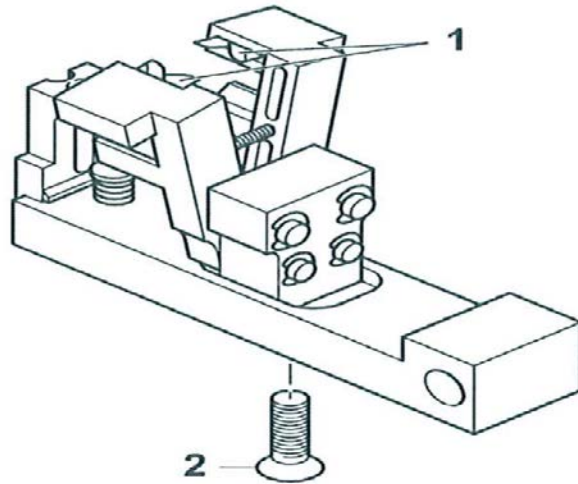

Fault Condition 5:

The ferrule is not separated from band.



Open the cover and disconnect the CP-881/E from main power supply.

If the cutter (1) is damaged or broken off, the cable crimped with the ferrule will not be separated from the band.

In this case, remove the tool insert (see also Chapter RETOOLING) and check the cutter (1). When the cutter (1) is defective, the ferrule locator (3) must be removed by unscrewing the cross-head screw (2) and a new locator for the corresponding cross section must be fitted.

The corresponding article number is stated in Chapter SPARE PARTS.

Diagram 28: Check the cutter

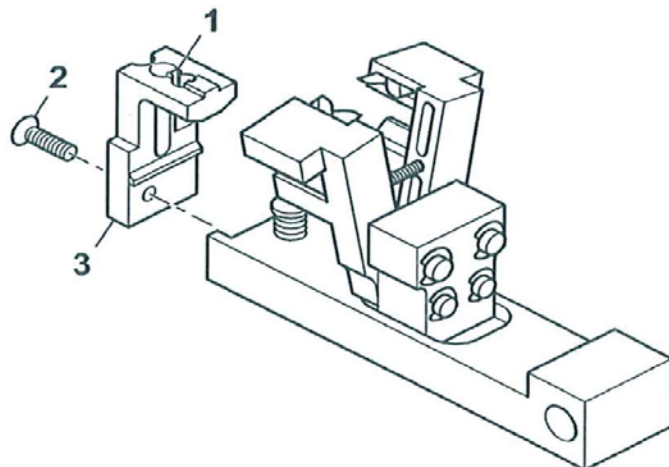

Fault Condition 6:

Counter respectively CP-881/E does not work.

1. Check main connection

Check that the main cable is connected correctly to the CP-881/E and the main power supply. Make sure that you have proper power supplied to the plug socket.

2. Check main fuses

Main connection must be opened, disconnect the CP-881/E from main power.

- Pull out main plug (1).
- Pull out the fuse holder (2).
- Check the main fuses (3).
- Replace defective main fuses (MC2S10.63). The corresponding article number is stated in Chapter **SPARE PARTS**.
- Put the main fuses into fuse holder.
- Insert the fuse holder.



Fuse holder must click into place.

Diagram 29: Check main fuses

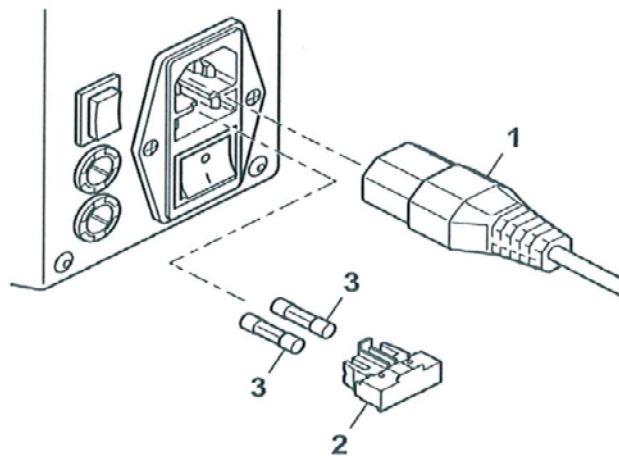
**Fault Condition 7:**

The CP-881/E works too slow but counter works.



Remove main fuses, disconnect the CP-881/E from main power.

- Pull out main plug (1).
- Unscrew the fuse holder (2).
- Check the device fuses (3).
- Replace defective device fuses (MC2S14.0). The corresponding article number is stated in Chapter **SPARE PARTS**.
- Insert device fuses into the fuse holder.
- Insert the fuse holder.

Diagram 30: Check device fuses

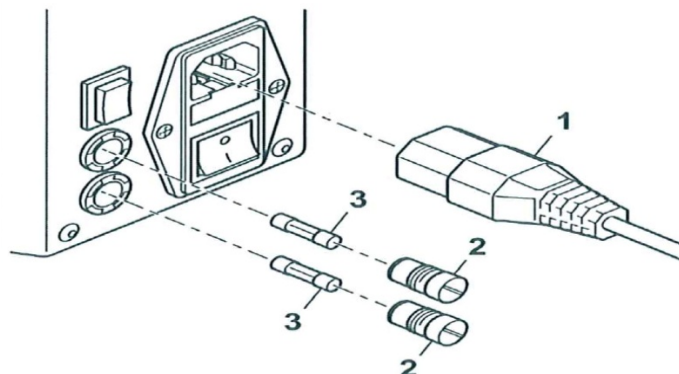



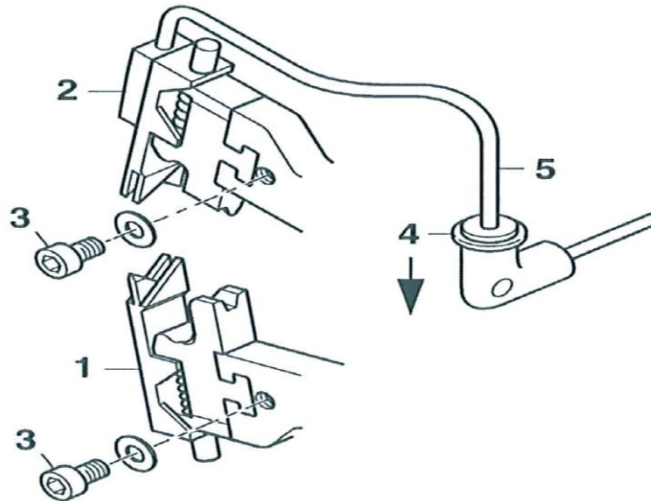

Fault Condition 8:**Crimp stamp or crimp forging die is defective.****Open the cover and disconnect the CP-881/E from main power.**



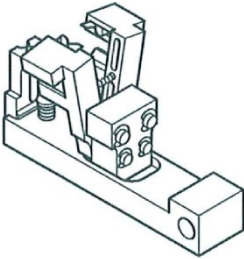
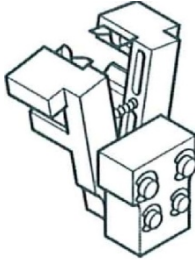
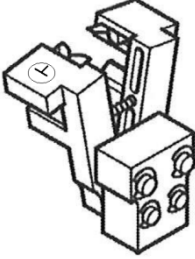
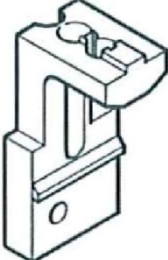

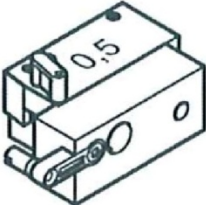
- Pull out main plug (1).
- Remove tool insert and ferrule feeder (see Chapter **RETOOLING**).
- Unscrew the allen screw (3) at defective crimp stamp (2) or crimp forging die (1).
- Press the ring (4) down and remove the hose.
- Replace the defective part. The corresponding article number is stated in Chapter **SPARE PARTS**.

**Plastic parts must be clean and free of grease.****Diagram 31: Replace crimp stamp / crimp forging die**

SPARE PARTS

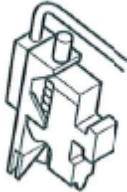
Part	Cross Section AWG (mm ²)	Part No.	Packing Unit
Tool Insert 	20 (0,5)	MC2SCH05	1 piece
	18 (0,75)	MC2SCH07	1 piece
	18 (1,0)	MC2SCH10	1 piece
	16 (1,5)	MC2SCH15	1 piece
	14 (2,5)	MC2SCH25	1 piece
Stripping Cutter 	20 (0,5)	MC2AM05	1 piece
	18 (0,75)	MC2AM07	1 piece
	18 (1,0)	MC2AM10	1 piece
	16 (1,5)	MC2AM15	1 piece
	14 (2,5)	MC2AM25	1 piece
Adjustable Stripping Cutter 	20 (0,5)	MC2AM05E	1 piece
	18 (0,75)	MC2AM07E	1 piece
	18 (1,0)	MC2AM10E	1 piece
	16 (1,5)	MC2AM15E	1 piece
	14 (2,5)	MC2AM25E	1 piece
Locator 	20 (0,5)	MC2LOC05	3 pieces
	18 (0,75)	MC2LOC07	3 pieces
	18 (1,0)	MC2LOC10	3 pieces
	16 (1,5)	MC2LOC15	3 pieces
	14 (2,5)	MC2LOC25	3 pieces

Part	Cross Section AWG (mm ²)	Part No.	Packing Unit
Ferrule Feeder 	20 (0,5)	MC2MAG05	1 piece
	18 (0,75)	MC2MAG07	1 piece
	18 (1,0)	MC2MAG10	1 piece
	16 (1,5)	MC2MAG15	1 piece
	14 (2,5)	MC2MAG25	1 piece
Wire Guiding Tube 	20 (0,5)	MC2 0071	2 pieces
	18 (0,75)	MC2 0072	2 pieces
	18 (1,0)	MC2 0073	2 pieces
	16 (1,5)	MC2 0074	2 pieces
	14 (2,5)	MC2 0075	2 pieces
Bolt 	----	MC2BOL	1 piece
Main Fuse  0,63 A/T/250 V	----	MC2SI0.63	2 pieces
Device Fuse  4,0 A/T/250 V	----	MC2SI4.0	2 pieces

Part	Cross Section AWG (mm ²)	Part No.	Packing Unit
<p>Crimp Die</p> 	----	MC2CGES	1 piece
<p>Crimp Stamp</p> 	----	MC2CSTE	1 piece
<p>Centering Fork Bottom</p> 	----	MC2 0011	1 piece
<p>Centering Fork Top With Tube</p> 	----	MC2 0013	1 piece
<p>Centering Fork Top Without Tube</p> 	----	MC2 0013K	1 piece