

THIS COPY IS PROVIDED ON A RESTRICTED BASIS AND IS NOT TO BE USED IN ANY WAY DETRIMENTAL TO THE INTERESTS OF PANDUIT CORP.

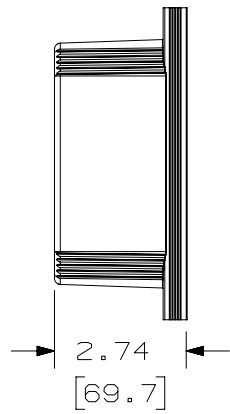

4X #6-20 1-3/4" COMBINATION HEAD SCREW

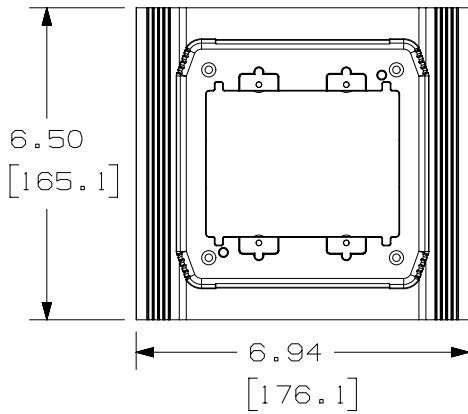
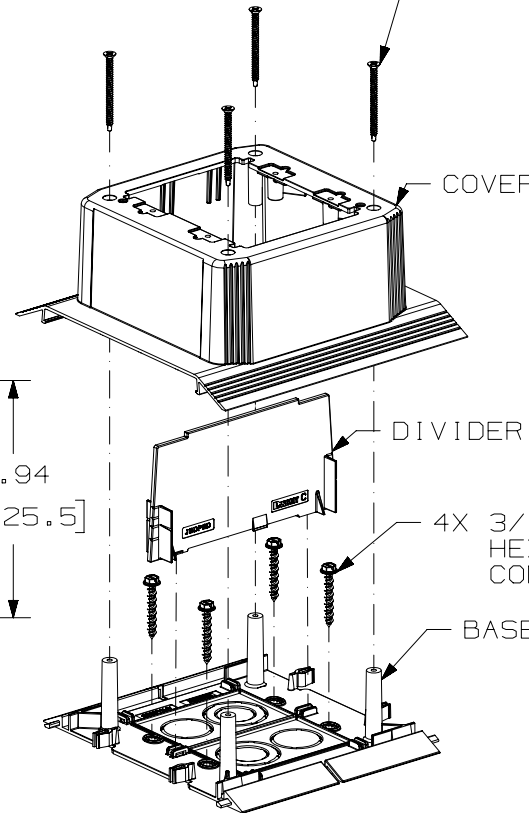

- NOTES:
1. VISIT OUR ON-LINE CATALOG AT WWW.PANDUIT.COM FOR A LIST OF CURRENT PARTS APPLICABLE FOR USE WITH THIS PRODUCT.
 2. DIMENSIONS IN [] ARE METRIC.
 3. WEIGHT: 0.5-1b (0.23-kg)
 4. PART INCLUDES:
 - 1- COVER
 - 1- DIVIDER
 - 1- BASE
 - 4- #6-20 1-3/4" COMBINATION HEAD SCREWS
 - 4- 3/16" X 1-1/4" HEX WASHER HEAD CONCRETE SCREW
 5. CONCENTRIC BREAKOUTS TO ACCOMMODATE CONDUIT SIZES OF 1/2", 3/4", AND 1" DIAMETERS.
 6. DIVIDER PROVIDES POWER AND DATA SEPARATION IMMEDIATELY FROM RACEWAY.
 7. RoHS COMPLIANT, UL 94V-0 MATERIAL

SEE NOTE 6

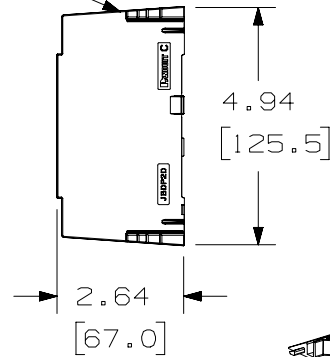

SEE NOTE 5

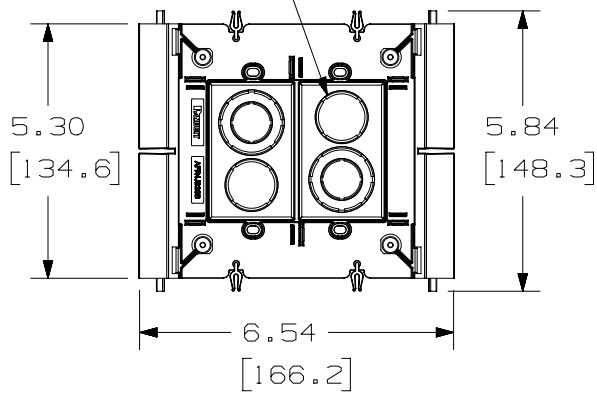

PART NUMBER		AFR4JB2S**		
TITLE		ABOVE FLOOR RACEWAY 4-CHANNEL DOUBLE GANG JUNCTION BOX		
CUSTOMER DRAWING				
ITEM REVISION NAME	00064EAC/00			
DATASET FILE NAME	00064EAC_DC/000			
MATERIAL		PVC		
DRAWING NUMBER		00064EAC-DC		
THIRD ANGLE PROJECTION				
DRAWN BY	DATE	CHK	SCALE	SIZE
BJN	8-24-17	ROJC	NONE	A
SHEET 1 OF 1				

REV	DATE	BY	CHK	APR	DESCRIPTION	ECN
00D	5/27/22	BJN	BSN	TAM	REMOVED COLOR TABLE	M09000QH
00C	12-28-21	BJN	ROJC	MMR	REMOVED IW COLOR REVISED & REDRAWN PREVIOUS REVISIONS REMVD FOR CLARITY	M09000PF

A-SIZE CUSTOMER