



### Model Number

**V15-W-PG9**

Female connector, M12, 5-pin, field attachable

### Features

- Screw terminal connection
- Metal locking

### Dimensions

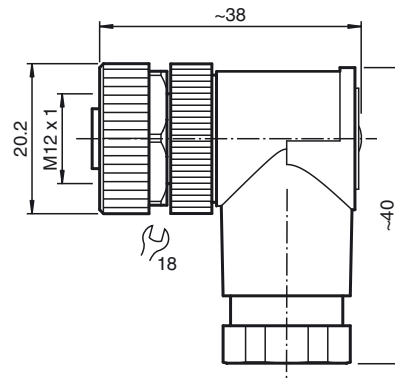

### Technical data

#### General specifications

Number of pins	5
Connection 1	socket
Construction type 1	right angle
Threading 1	M12
UL File Number	E363587

#### Electrical specifications

Operating voltage	$U_B$	max. 125 V AC/DC
Test voltage		> 1500 V <sub>eff</sub> AC
Operating current		max. 4 A
Volume resistance		< 8 mΩ

#### Ambient conditions

Ambient temperature	-25 ... 85 °C (-13 ... 185 °F)
Pollution Degree	3

#### Mechanical specifications

Degree of protection	IP67
Connection	1 x M12 right-angled socket Screw terminals for max. 0.75 mm <sup>2</sup>
Material	
Contacts	CuZn
Contact surface	CuSnZn
Body	PBT
Slotted nut	CuZn, nickel-plated
Cable	
Sheath diameter	6 ... 8 mm

#### Compliance with standards and directives

Standard conformity	
Degree of protection	EN 60529:2000

### Electrical connection

