



Model Number

UB250-F12P-EP-V15

Ultrasonic direct detection sensor

Features

- **Switching point adjustment via potentiometer**
- **Selectable sound lobe width**
- **Synchronization options**
- **Very small unusable area**
- **Push-pull output**
- **Temperature compensation**

Diagrams

Characteristic response curve

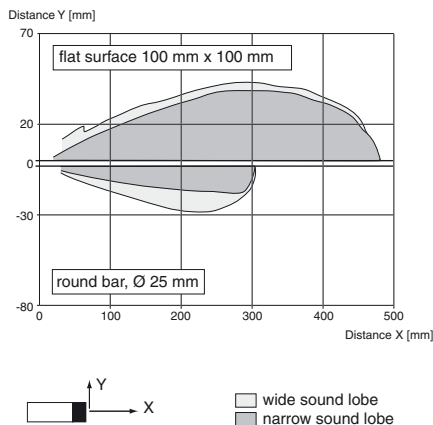

Technical data

General specifications

Sensing range	20 ... 250 mm
Adjustment range	25 ... 250 mm
Dead band	0 ... 20 mm
Standard target plate	100 mm x 100 mm
Transducer frequency	approx. 400 kHz
Response delay	approx. 20 ms

Indicators/operating means

LED green	Operating display
LED yellow	switch output
LED red	solid: stop plate switch point adjuster flashing: error

Electrical specifications

Operating voltage U_B	10 ... 30 V DC , ripple 10 % _{SS}
No-load supply current I_0	≤ 25 mA

Input/Output

Synchronization	1 synchronous connection, bi-directional 0-level: $-U_B \dots +1 V$ 1-level: $+4 V \dots +U_B$ input impedance: > 12 kΩ synchronization pulse: ≥ 100 μs, synchronization interpulse period: ≥ 2 ms
Synchronization frequency	≤ 200 Hz
Common mode operation	≤ 200 Hz
Multiplex operation	≤ 200/n Hz, n = number of sensors

Input

Input type	1 input for sound lobe adjustment small sound beam: $-U_B \dots +1 V$ wide sound beam: $+4 V \dots +U_B$ or open input input impedance: > 10 kΩ switching delay: 1 s
------------	--

Output

Output type	Push-pull output, short-circuit protected, reverse polarity protected
Rated operating current I_e	200 mA , short-circuit/overload protected
Default setting	Switching point: 250 mm output behavior: NO contact
Voltage drop U_d	≤ 3 V
Repeat accuracy	≤ 1 %
Switching frequency f	20 Hz
Range hysteresis H	1 % of the set operating distance
Temperature influence	± 1.5 % of full-scale value

Ambient conditions

Ambient temperature	-15 ... 70 °C (5 ... 158 °F)
Storage temperature	-40 ... 85 °C (-40 ... 185 °F)

Mechanical specifications

Connection type	Connector M12 x 1 , 5-pin
Degree of protection	IP54
Material	
Housing	Frame: nickel plated, die cast zinc, Laterals: glass-fiber reinforced plastic PC
Transducer	epoxy resin/hollow glass sphere mixture; foam polyurethane, cover PBT
Mass	60 g

Compliance with standards and directives

Standard conformity	
Standards	EN 60947-5-2:2007 + A1:2012 IEC 60947-5-2:2007 + A1:2012

Approvals and certificates

UL approval	cULus Listed, General Purpose
CSA approval	cCSAus Listed, General Purpose

Release date: 2016-04-25 09:32 Date of issue: 2016-04-25 202089_eng.xml

Dimensions

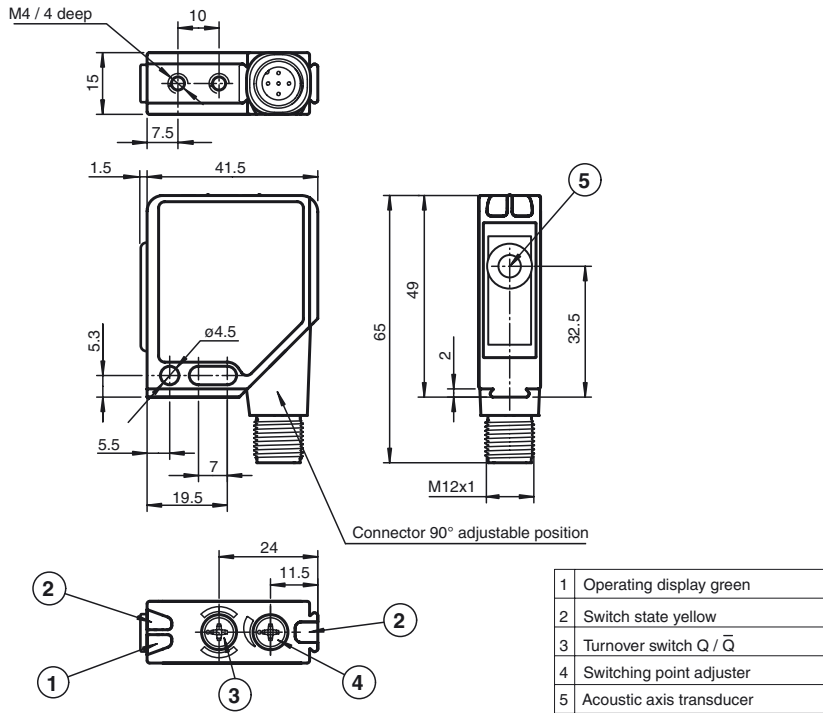

Electrical Connection

Standard symbol/Connections:
(version EP, pnp/npn)

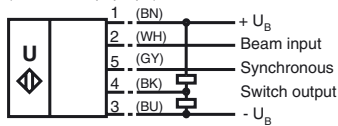

Core colours in accordance with EN 60947-5-2.

Pinout

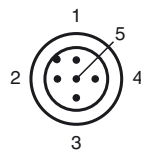

Wire colors in accordance with EN 60947-5-2

1	BN	(brown)
2	WH	(white)
3	BU	(blue)
4	BK	(black)
5	GY	(gray)

Additional Information

Switching output function

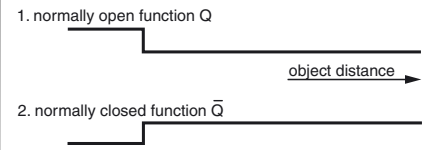

Accessories

OMH-K01

dove tail mounting clamp

OMH-K02

dove tail mounting clamp

OMH-K03

dove tail mounting clamp

OMH-01

Mounting aid for round steel \varnothing 12 mm or sheet 1.5 mm ... 3 mm

OMH-06

Mounting aid for round steel \varnothing 12 mm or sheet 1.5 mm ... 3 mm

OMH-MLV12-HWG

Mounting bracket for series MLV12 sensors

OMH-MLV12-HWK

Mounting bracket for series MLV12 sensors

V15-G-2M-PVC

Female cordset, M12, 5-pin, PVC cable

Synchronisation

To suppress mutual influence, the sensor is equipped with a synchronisation connection. If this is not activated, the sensor works with an internally generated clock. Synchronisation of multiple sensors can be achieved in the following ways.

External synchronisation

The sensor can be synchronized by external application of a square wave voltage. A synchronisation impulse on the synchronisation input leads to the execution of one measurement cycle. The impulse width must be larger than 100 μ s. The measurement cycle starts with the falling flank. A low level > 1 sec or an open synchronisation input puts the sensor in normal mode. A high level on the synchronisation input deactivates the sensor.

Two operational modes are possible

1. Multiple sensors are controlled using the same synchronisation signal. The sensors work in synch.
2. The synchronisation impulses are cyclically fed to only one sensor at a time. The sensors work in multiplex mode.

Autosynchronisation

The synchronisation connections of up to 10 sensors are connected together. These sensors then work in multiplex mode after power is switched on. The activation delay is increased corresponding to the number of synchronised sensors.

Note:

If the synchronisation option is not used, the sync. input should be connected to ground (0V), or the sensor connected using a V1 connector cable (4-pin).

Selection of beam characteristics

By switching the beam input, the activation characteristics of the ultrasound sensor can be selected. If the beam input is open or connected to +U_B, the sensor works with a wide ultrasonic cone. A beam input connected to -U_B causes the sensor to work with a narrower ultrasonic cone. This setting is preferred when an object in the vicinity of the sensor is close to the ultrasonic beam, and should be suppressed. The characteristic of the ultrasonic cone can be changed during sensor operation. Switching the sound cone characteristics becomes active one second after the change to the signal level at the beam input.

Setting the switch point

The ultrasonic sensor possesses a switch output, of which the switching point can be set simply and precisely using the built-in 12-position potentiometer. Using the switch Q / \bar{Q} which is also easy to find on the upper side of the sensor, the effective direction of the switching output can be selected.

There are two different output functions which can be selected

1. one switching point, normally open
2. one switching point, normally closed

LED display

	Opening function (Q)	Closing function (\bar{Q})
LED green:	Power On	
LED yellow:	Switch state Object outside switching area, or no object	Switch state Object detected in switching area
LED red	Potentiometer for setting of switch point at "limit"	
LED red flashing	Ultrasonic error	

Release date: 2016-04-25 09:32 Date of issue: 2016-04-25 202089_eng.xml