

# THERMAL MANAGEMENT

—  
MAIN CATALOGUE  
EDITION 20.2

THERMAL MANAGEMENT FOR  
ELECTRICAL ENCLOSURES  
AND PROCESS COOLING.

Filterfans 4.0 | Cooling Units  
Air/Water Heat Exchangers  
Air/Air Heat Exchangers | Chillers  
Heaters | Thermostats | Hygrostats  
Accessories | Signaling Technology

# We make companies more productive.

## Why Pfannenberg?

For more than 60 years, we have been helping guarantee production safety for companies throughout the world. Our mission is to satisfy the increasing demands of modern industries by developing progressive ideas. This led to the invention of the filterfan and other milestones in the field of thermal management for electrical enclosures and process cooling.

A spirit of invention and German engineering genius are not our only strengths. We are also proud of the close relationships we maintain with our clients and their industries.

Pfannenberg's broad experience in delivering individual thermal management solutions positions us to provide unique, innovative benefits to our clients. Through our wide product range and a consultative team approach we develop customised high quality, cost effective, energy efficient solutions for demanding industrial requirements. This is the real value for our customers.

The current edition 20.2 of our catalogue presents our range of products and services in a new form. Subdivided into four chapters not only makes it easier for you to find what you need, but also demonstrates that we can provide the perfect solution for any type of requirement – with high-volume products, our comprehensive solution-orientated consultative approach, worldwide services and our industry expertise.

To understand more about how we can help you, please contact your Pfannenberg local sales office. As one of the few companies around the world to have developed and produced a complete range of industrial thermal management solutions in-house, we have a wide range of expertise which we would like to share with you.

True to our motto "Sharing Competence", we place the knowledge and technical expertise of our engineers and experts at your disposal so that you can find the best possible solutions for your requirements. Today and in the future.

What can we do for you?

Andreas Pfannenberg, CEO



You need perfect solutions.  
That is exactly what we are geared to.

With our products and services divided into four segments, we are guided by the needs of our clients and can supply the required solution to any need. With top quality, superior energy and cost efficiency.

# P

## PRODUCTS

From cooling to heating – you will find everything you need for the thermal management solution that perfectly meets your needs.

More on page 16.

# S

## SOLUTIONS

Solution-orientated advice and development – the individual answer to specific requirements.

More on page 188

# S

## SERVICES

Partnership and reliability worldwide – a service concept going far beyond the provision of spare parts.

More on page 202.

# I

## INDUSTRIES

Our expertise takes you further – benefit from our wide-ranging experience in many industrial fields.

More on page 210.

Prologue.....	2
Service Offering .....	4
How to select the right product .....	10
Explanation of Approvals.....	15

# PRODUCTS

## P

### FILTERFANS 4.0

Filterfans IP 54 .....	26
Filterfans IP 55 .....	30
Slim Line Filterfans .....	34
Top mounting Filterfans .....	35
EMC Filterfans .....	36
Internal Enclosure Fan and other Accessories.....	39
Performance curves .....	158

### AIR/AIR HEAT EXCHANGERS

PAS Air/Air Heat Exchangers for side mounted installation .....	46
Performance curves .....	164

### COOLING UNITS

DTI/DTS Cooling Units for partially recessed and side mounted installation.....	60
DTT Cooling Units for roof mounting.....	66
Outdoor Cooling Units DTS according to the NEMA Standard .....	74
Accessories .....	82
Performance curves .....	165

### AIR/WATER HEAT EXCHANGERS

PWI/PWS Air/Water Heat Exchangers for partially recessed and side mounted installation .....	90
PWD Air/Water Heat Exchangers for roof mounting .....	100
Performance curves .....	170

### CHILLERS

Rack Chillers (water) .....	110
PC Chiller (water) .....	112
CCE Chillers (water) .....	116
EB 2.0 Chillers (water).....	120
EB 2.0 L Chillers (water).....	124
EB XT Chillers (water).....	128
EB 2.0 OL Chillers (oil).....	132
PWW Passive Cooling System (water) .....	136
Performance curves .....	175

### HEATERS, THERMOSTATS AND HYGROSTATS

FLH Radiant Heaters.....	144
Surface temperature-limited Radiant Heaters .....	146
PRH Mini Radiant Heaters.....	147
FLH Fan Heaters .....	148
FLH-T Fan Heaters with integrated thermostat .....	150
PFH Compact Fan Heaters .....	152
PFH-T Compact Fan Heaters with integrated thermostat.....	153
FLZ Thermostats.....	154
FLZ Hygrostats .....	156

### CONTROL CABINET ACCESSORIES

LED Lamp Systems .....	157
Sockets, Pressure Compensation Device, Mounting Support.....	157

### SIGNALING TECHNOLOGY

PYRA Flashing Lights.....	184
PYRA Flashing Light Sounders.....	184
PATROL Sounders .....	185
PATROL Flashing Sounders.....	186
BR 35 Signal Towers.....	187
BR 50 Signal Towers.....	187

### SOLUTIONS

## S

Product Development and Validation .....	192
Special Process Requirements .....	194
Product and System Development .....	198

### SERVICES

## S

Commissioning, Maintenance and Repair Service.....	206
Training Courses and Spare Parts.....	208

### INDUSTRIES

## I

Automotive .....	214
Food & Beverage .....	218
Infrastructure .....	222
Energy .....	226
Contacts.....	230

Protecting man, machine and the environment.

The more stable the working climate is, the longer the components last.

Electrical enclosures and their high-performance components are indispensable for the control of today's production processes. However, it is easy to imagine the consequences when sensitive circuitry and modules become overheated: systems shut down, creating the risk of production losses and the premature ageing of components.

To ensure that sensitive electronic components continue to function reliably in the long-term, the temperature inside electrical enclosures should not exceed or fall below defined limits. Tests have shown

that an increase in temperature of as little as 10 K shortens the lifetime of electrical components by more than 50 %.

This exemplifies the effect of perfect thermal management of electrical enclosures – it prevents critical temperature fluctuations, avoids overheating and protects against the formation of condensates. In this way, it contributes significantly to increasing failure safety and prolonging the lifetime of electronic control units.

The life expectancy of film capacitors decreases as the ambient temperature increases.

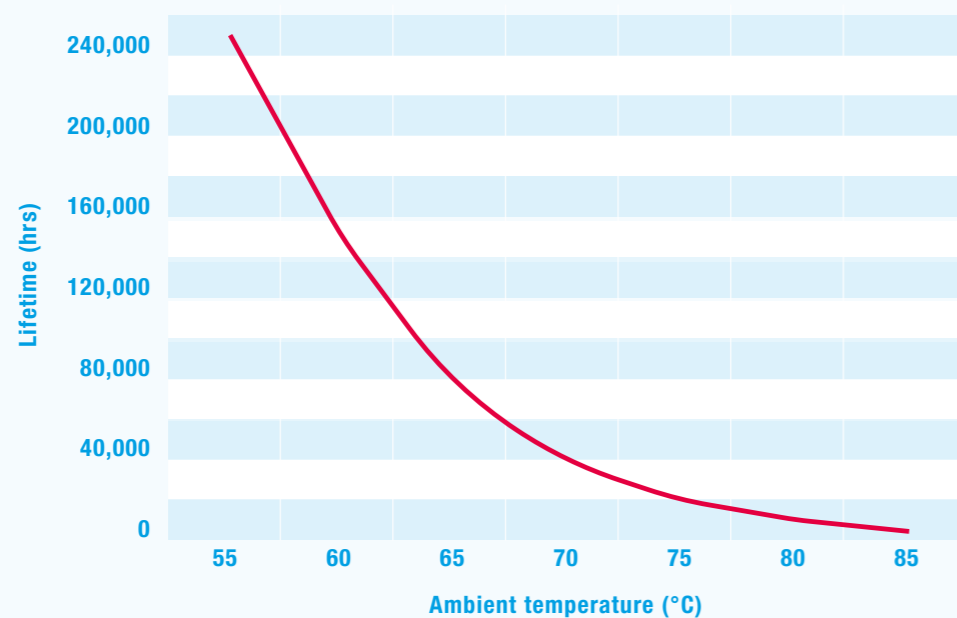

An increase in temperature of 10 K shortens the lifetime of electrical components by more than 50 %.

Too hot – too cold – too humid – broken. Protect your electronic systems against stress.

To be able to choose the most suitable thermal management solution, it is essential to start by considering the location of the unit and the ambient temperature. This is because the environment in the electrical enclosure can also be affected by weather conditions, solar radiation or other external heat sources.

Regardless of whether they are exposed to climatic or technical conditions, even particularly low ambient temperatures impact on specific thermal management solutions. This means that electrical enclosures may need to be heated to counter the

effects of excess cold and the associated risks of condensate formation such as corrosion and short circuiting.

Another major factor to be taken into account is the ambient air quality – for example, if the air is excessively humid or dust, oil or gas loaded.

Pfannenberg's thermal management solutions address all these factors and create exactly the right conditions that sensitive electrical enclosure electronics need: a stable operating environment that is ideally pitched.

Both internal thermal losses and external factors make thermal management necessary.

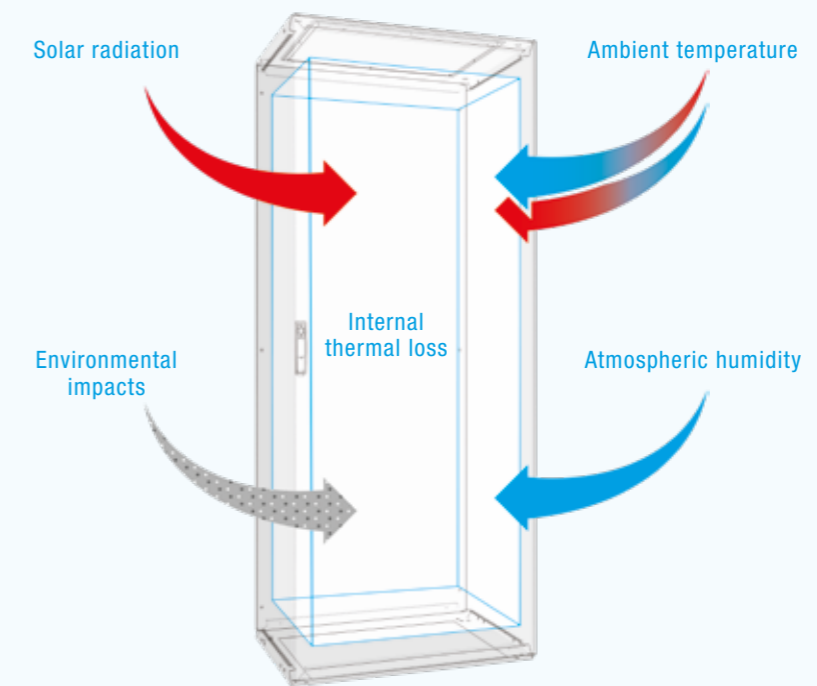

5 different influencing factors make thermal management necessary.

## How to find the right product. For any location and any temperature.

**Analyse your operating conditions to make the right choice.** The most suitable thermal management solution depends on the particular ambient conditions – and to a major degree the prevailing temperature. Is it consistently lower than that required in the electrical enclosure? Is it higher? Is the air contaminated? Would water cooling instead of air cooling be more appropriate? Whatever the answer, we have the right product.

### Low ambient temperature?

If the ambient temperature is always lower than the temperature needed in the electrical enclosure, filterfans will provide economic cooling. If the air is heavily contaminated with dust or fluids, air/air heat exchangers are the recommended choice.

### Cooling with filterfans.

A filterfan sends cool, filtered ambient air into the interior of the electrical enclosure. At the same time, it increases the pressure slightly, which prevents

dust from infiltrating into the enclosure. Fitting a filterfan to the lower third of the electrical enclosure and placing the exhaust filter as high as possible also aids natural air convection processes and avoids the build-up of heat pockets.

### Cooling with air/air heat exchangers.

An air/air heat exchanger is used when the ambient air is heavily contaminated (dust, fluids). The external and internal air circuits are isolated from each other in order to form a hermetic seal between the interior

of the electrical enclosure and environmental influences. The use of an air/air heat exchanger requires the ambient temperature to be consistently >10 K below the temperature needed in the electrical enclosure.

### High ambient temperature?

If the ambient temperature is consistently high or higher than the temperature needed in the electrical enclosure, active cooling units are used. If the ambient air is heavily contaminated with oil/dust or there is a hostile/humid environment – air/water heat exchangers are recommended.

### Cooling with active cooling units.

An active cooling unit takes in air from inside the electrical enclosure and lowers its temperature to a suitable level, in order to guarantee a defined temperature in the electrical enclosure. The lowest

temperature inside the cabinet is not necessarily the best. Our units are preset to 35 °C, which achieves a good balance between useful lifetime and condensate build up. It is essential to have good air intake and air exhaust features in the cooling unit's external air circuit to ensure proper heat energy dispersal into the environment.

### Cooling with air/water heat exchangers.

An air/water heat exchanger works without servicing and independently of ambient air quality. Suitable areas for use include extremely high ambient temperatures (>55 °C) and in oily, dusty, humid and aggressive ambient air (IP protection system up to IP 65). Since it uses water to dissipate thermal losses, it is also suitable for use in air-conditioned manufacturing areas in which additional heating is not allowed.

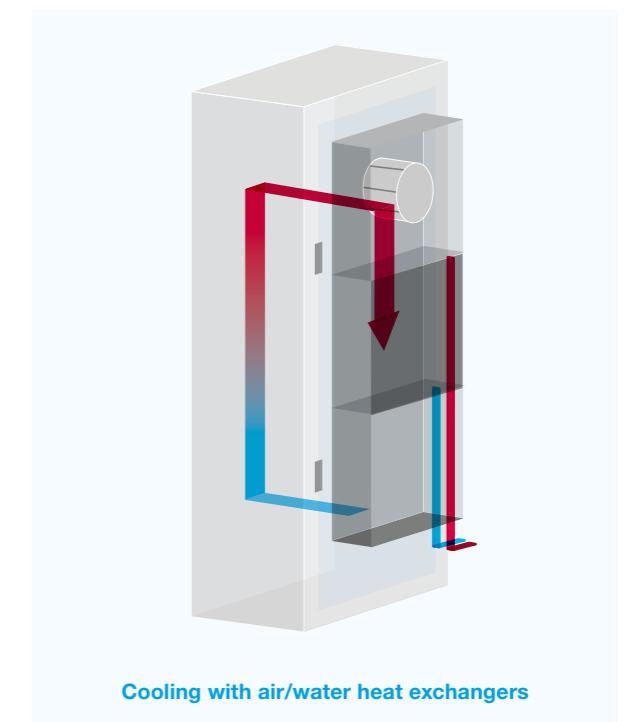
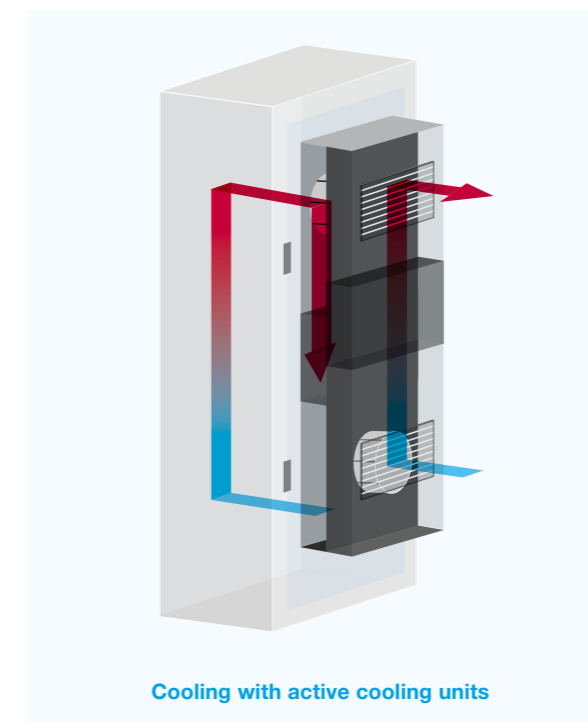
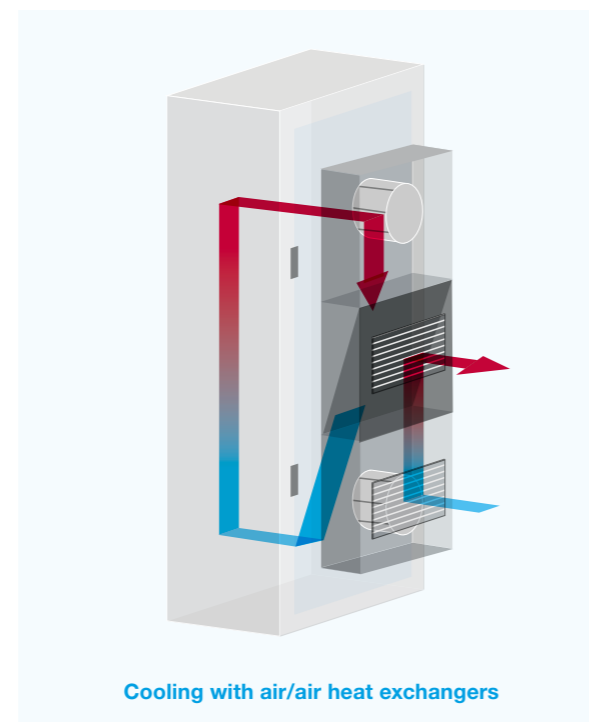
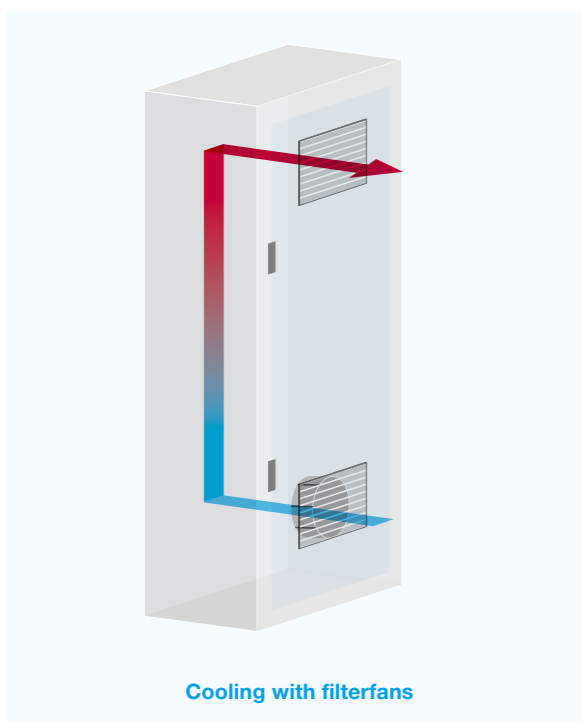

## Increase performance with our complete solutions.

### Unsurpassed efficiency: Product combinations.

System solutions combine the power of different products and optimise the efficiency, environmental performance and safety by consistently providing the required refrigerant in the required temperature, or by even after switching off the unit, preventing condensation in the control cabinet.

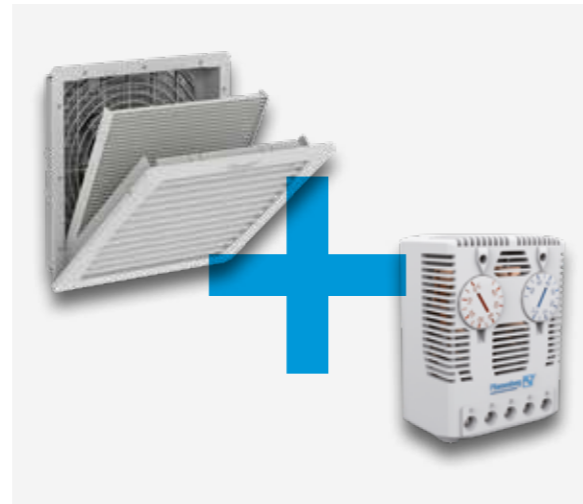

### Air/water heat exchanger and chiller.

The combination of an air/water heat exchanger and a chiller guarantees a safe and silent cooling system, along with being able to operate regardless of the quality of the ambient air at the installation site. The closed pipeline system ensures that all cooling tasks to control panel, system, or machine can be solved easily and economically.

### Thermostats, hygrometers and heaters.

Electrical enclosure heaters in combination with thermostats and hygrometers ensure that the correct temperature is always available. In addition to savings on energy and a better environmental balance, the combination of heaters with thermostats and hygrometers offer greater reliability of the production process.



### Filterfans and thermostats.

The interaction of filterfans and thermostats leads to a significant energy-, material- and time savings. The thermostat controls the operation of the filterfan, which reduces the energy consumption and extends significantly the lifetime of the fan. This results in a reduced consumption of filter mats and decreased time for cleaning. Improved environmental performances, lower costs and more reliability for your production process are the bottom line.

## Reliable data directly on the screen.

Planners and designers need security when configuring an optimal air conditioning and signalling solutions. With the Pfannenbergs Sizing Software (PSS) we offer you a free and user friendly instrument, which immediately provides a qualified device recommendation. You can avoid costly over-sizing as well as dangerous under-dimensioning already in the planning phase or review the dimensioning.

Often, individual circumstances make it difficult choosing the right solution. The PSS contains an open library, in which custom specific components can be easily maintained. In this way, we ensure that we can cover the complete spectrum of possible applications and solutions for each application in the field of thermal management, re-cooling and signalling.

The PSS is online available at:  
[www.pfannenbergs.com/pss](http://www.pfannenbergs.com/pss)

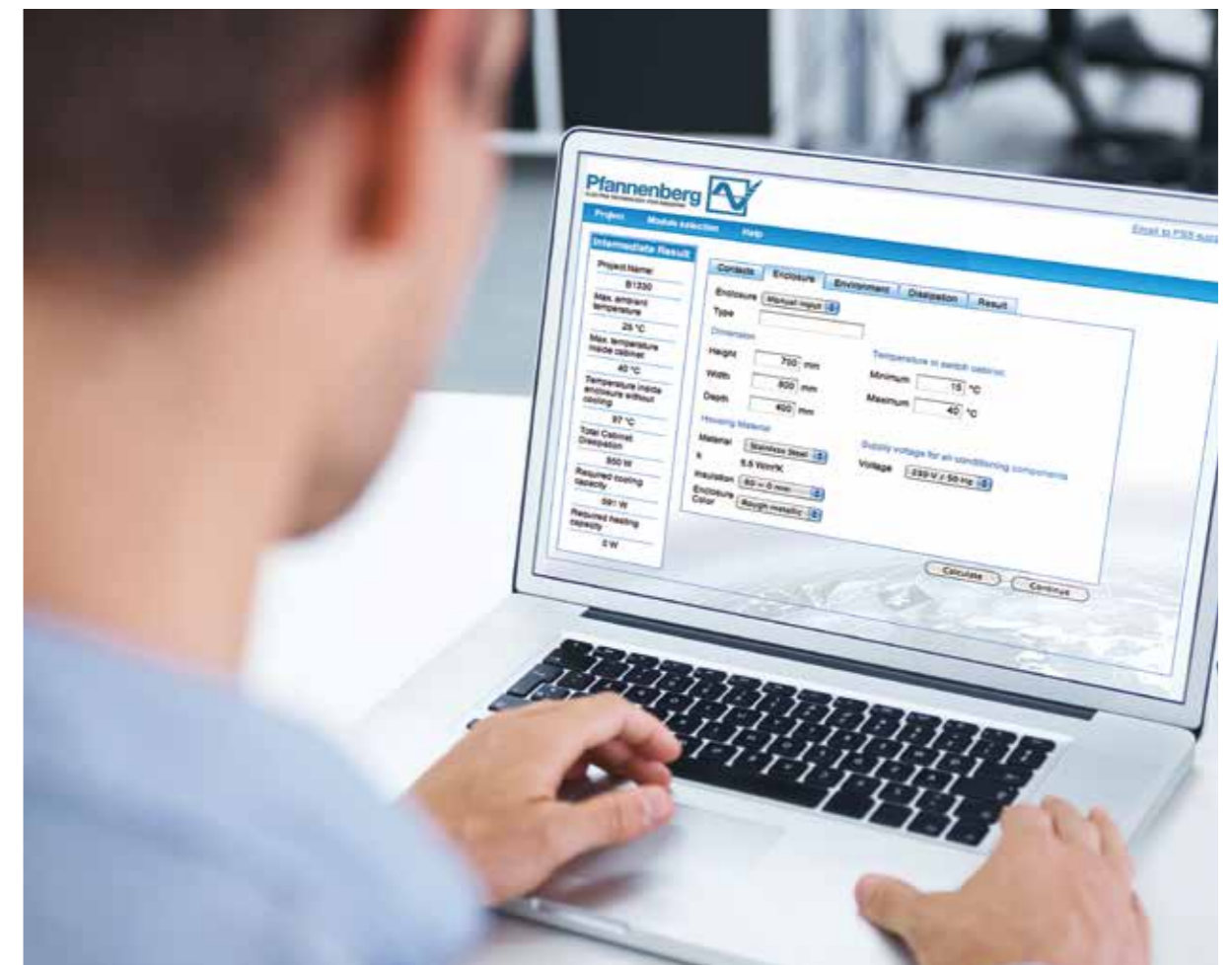

## Selection of the preferred thermal management method, based on environmental conditions.

PRODUCTS		AMBIENT TEMPERATURE			DUST			WATER			SPECIFIC			
		Low <5 °C	Moderate	High >40 °C	Clean	Moderate	Heavy	Dry	High Humidity	Wash-down	Corrosive	Oily	Sea air	Outdoor
FILTERFANS	PF IP 54	○	+	-	+	+	-	+	○	-	-	○	-	-
	PF IP 55	○	+	-	+	+	○	+	○	-	-	-	-	+
HEAT EXCHANGERS	Air/Air PAI   PAS 6000	+	+	-	+	+	+	+	+	-	○	○	-	○
	Air/Water PWI   PWS 6000   PWD 5000   PWS 7000	○	+	+	+	+	+	+	+	-	+	+	○	○
COOLING UNITS	€COOL DTI   DTS   DTT 6000	-	+	+	+	+	○	+	+	-	-	○	-	-
	Basic DTI   DTS 9000	-	+	+	+	+	○	+	+	-	-	○	-	-
	Outdoor DTS 3000	○* (+*)	+	+	+	+	+	+	+	-	○	○	○	+
	Wash-down DTS 3000	○ (+*)	+	+	+	+	+	+	+	+	+	○	○	+
CHILLERS	CCE	-	+	○	+	+	○	+	+	-	-	○	-	○
	Rack	-	+	-	+	○	-	+	+	-	-	○	-	-
	EB	- (+*)	+	○	+	+	○	+	+	-	-	○	-	○ (+*)
	PWW	○	+	+	+	+	+	+	+	-	○	+	○	- (○*)
HEATERS	FLH   PFH	+	+	○	+	+	+	+	+	-	○	○	○	○
THERMOSTATS   HYGROSTATS	FLZ	+	+	○	+	+	+	+	+	-	○	○	○	○

- + recommended
- applicable
- not recommended
- \* option

We are happy to support you personally with the selection of the best thermal management method for you. Please contact us. You can find the addresses at the end of the catalogue.

## Explanation of approvals.

**Please note following information in reference to our approvals:** Most Pfannenbergs products are (in the standard version) already equipped with various approvals. In some products the approvals are not included in the standard version, but need to be ordered explicitly and then manufactured in accordance with official requirements. There are, for example, instances in which approvals expire and are then not renewed due to too little demand. **Therefore, when making inquiries and placing orders, please state which approvals are necessary for the products you require.**

In the following, we would like to provide you with some information to make it easier for you to choose the appropriate approvals for the markets relevant to you. We are available, should you have any questions or suggestions. You can find our contact details at the end of this catalogue or on [pfannenberg.com](http://pfannenberg.com).



The organisation Underwriters Laboratories (UL) checks equipment and awards seals of approval. It differentiates between components which need to be installed to be used and finished products which can be used by themselves.



UL recognised component



UL listed product

The most important markets/countries for the use of the UL logos are the United States and Canada. Approvals for the United States are marked with 'US' at the bottom right of the logo. Approvals for Canada with a 'c' at the bottom left. If there is no country code, then it has approval for the US market. The UL approval is not a mandatory approval for the North American market, but it can make it easier to import there. In addition, the approval generally has a high degree of acceptance among customers.



The logo EAC stands for EurAsian Conformity. It is comparable to the European CE mark, so it stands for the product's safety. The EAC mark is the approval of the Eurasian economic community and is valid for Russia, Belarus and Kazakhstan. There is no specific identification of the country by a code. The mark is issued by the respective manufacturer on their own authority, but always with the involvement of an official certification body. The EAC is the successor of the GOST approval.



The Type 12 approval describes a protection system similar to the IP rating. Type 12, however, may not be awarded by the manufacturer itself like the IP rating, but only by an external, recognised testing organisation such as UL, NEMA or CSA. Type 12 corresponds roughly with an IP 52 rating.



The CE classification documents the compliance with the European regulations relevant for the product. It is not a test mark, but an administrative one. The CE marking was created mainly to guarantee safe products for consumers within the European Union. The CE marking is often referred to as "passport" for the European single market. The CE marking confirms the complete compliance with the "basic (safety) requirements" which are specifically determined in EU directives.



The Canadian Standard Association is the Canadian counterpart to the United States' UL organisation. The same test specifications are used as for the UR/UL classification. The CSA logo is valid for the Canadian market.

# PRODUCTS

Quality and quantity – attributes of our high-volume products for the thermal management in electrical enclosures. Rapid availability is the hallmark of this extensive range, which we keep good stock levels of to meet high market demands. The range includes fliterfans, active cooling units, air/air and air/water heat exchangers, chillers, heaters, thermostats and hygostats – plus electrical enclosure accessories and signaling devices.

# Trust the Original.



## **ECOOL** Filterfans 4.0. Superiority in fourth Generation.

When it comes to safe and cost-effective cooling of control cabinets with filtered ambient air, our filterfans are the first choice. Since Otto Pfannenberg invented it in 1958, they have held a leading position in the market.

The latest generation is even expanding this lead – with no fewer than 11 well-thought out and patent-protected details. One example worth mentioning here is the closed housing, which reaches guaranteed high system of protection IP 54 and IP 55, or the fluted filter mat which, in the IP 55 model, keeps the volume flow constantly high but increases the service life (time between 2 mat changes) by 300 %.

Our **ECOOL** series sets standards in terms of capacity, cost-efficiency and maintenance friendliness.

Protecting man, machine and the environment.

# A suitable product for every requirement.

The comprehensive range of Pfannenberg filterfans provides solutions for various requirements. The units can be installed on the side or on the top. The application can be inside or outside. Also in an EMC shielded version or UV resistant.



### Filterfans IP 54.

- As standard in RAL 7035 grey and RAL 9011 black.
- IP 54 protection, closed frame prevents unfiltered air from penetrating.
- Patented tool-free 4-corner fastening system enables installation in seconds.

More on page 26.



### Filterfans IP 55.

- For demanding applications indoors and outdoors.
- Innovative filter mat technology for outstanding airflow.
- UV protection due to special plastic.
- IP 55 protection.

More on page 30.



### Slim Line Filterfans IP 55.

- For demanding applications indoors and outdoors.
- Reduced installation depth for optimised air distribution.
- UV protection due to special plastic.
- IP 55 protection.

More on page 34.



### Top mounting Filterfans.

- For indoor use in constricted spaces.
- Optimal airflow and temperature distribution.
- UV protection due to special plastic.
- IP 33 and IP 54 protection.

More on page 35.



### EMC Filterfans.

- For reliable use near electromagnetic fields.
- Environmentally friendly, no metallised plastics.
- Safe contact surface without beryllium-copper seal.
- IP 54 protection.

More on page 36.



# Possibilities for the use of filterfans.

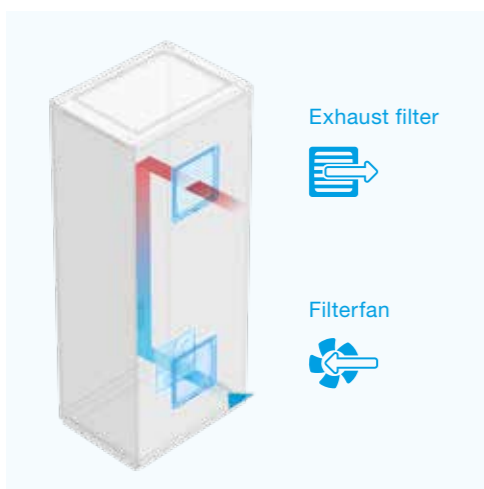

### Version 1

- A filterfan blows the cold air into the lower section.
- The heated air gets out via an exhaust filter.

This is the standard application.

The advantage is that there is a slight over pressure in the housing. Therefore, no dust can penetrate through cracks and crevices.

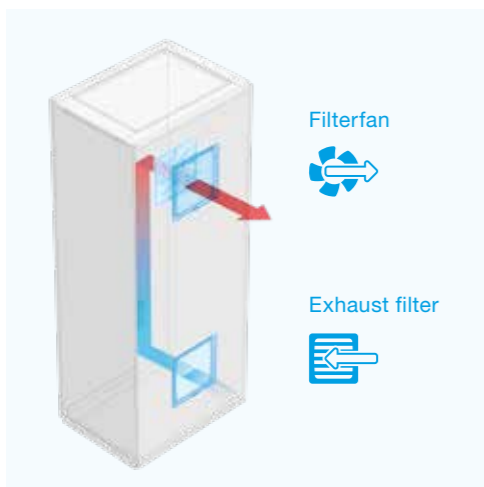

### Version 2

- A filterfan sucks the air out of the upper section of the housing.
- Cold air moves into the lower area via an exhaust filter.

The advantage of this layout is an even airflow through the whole housing cross section. However, dust can enter through cracks as a result of the negative pressure.

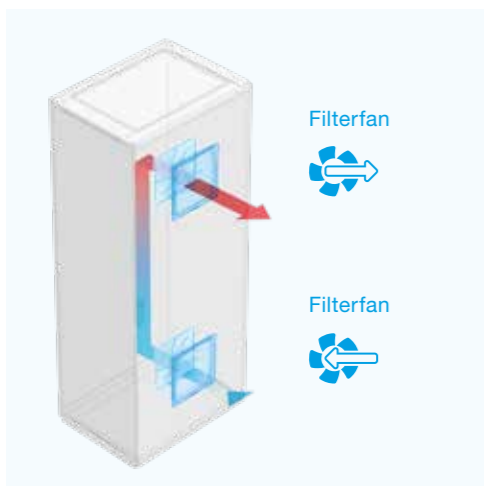

### Version 3

- A filterfan blows the cold air into the lower section and a second fan in the upper section sucks the heated air out again.
- Only the same types can be used in pairs.

As a result of the layout, the static pressure loss of the filter mats is compensated. The layout promotes the free volume flow of a filterfan.

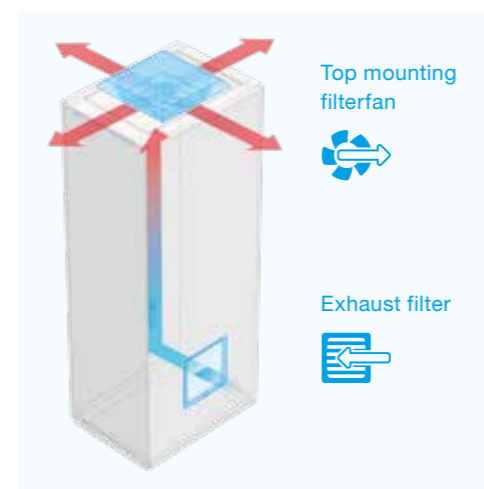

### Version 4

- A top mounted filterfan sucks the air out of the housing.
- Cold air moves into the lower section by means of an exhaust filter.

The advantage of this layout is an even airflow through the whole housing cross section. However, dust can enter through cracks as a result of the negative pressure.

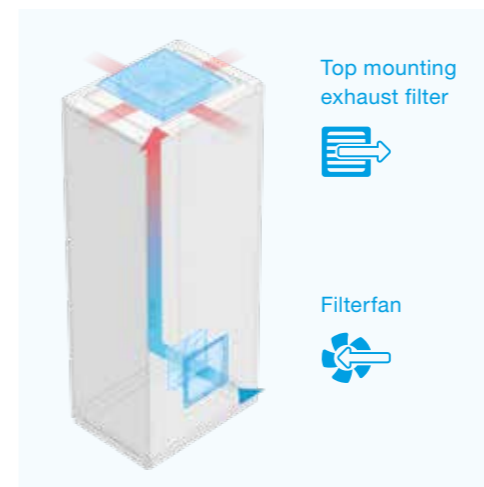

### Version 5

- A filterfan blows the cold air into the lower section.
- The heated air exits through a top mounted exhaust filter.

The advantage is that there is a slight over pressure in the housing. Therefore, no dust can penetrate through cracks and crevices.

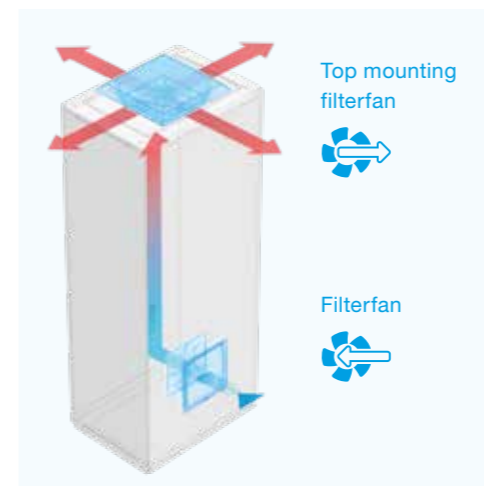

### Version 6

- A top mounted filterfan sucks the air out of the housing.
- A filterfan blows the cold air into the lower section.

As a result of the layout, the static pressure loss of the filter mats is compensated. The layout promotes the free volume flow of a filterfan.

# Assembly, Energy, Air, Maintenance – Your Benefits.

Well thought out details optimise your cost balance:



### Compatibility.

Filterfans 4.0 can be integrated into existing applications easily since most of the housing cut-outs comply with the Pfannenberg standard.



### Time.

The patented 4-corner fastening system allows for a tool-free installation in seconds and guarantees a secure hold.



### Maintenance.

The click mechanism enables a filter mat replacement in seconds.



### Air.

Airflow optimised fins and rotor blades guarantee maximal airflow with minimal energy consumption.



### Efficiency.

Filterfans 4.0 can be equipped with an optional thermostat – only operate when cooling is actually necessary.



### Life span.

With the fluted filter mats, filterfans 4.0 reach IP 55 system of protection. The intervals at which they need to be replaced extend up to 300 % longer than with conventional filter media.

## ECOOL Filterfans 4.0 at a glance

cULus approval for Pfannenberg Filterfans

TYPE	INSTALLATION SIZE	AIRFLOW RATE <sup>1</sup>	RATED VOLTAGE	CUT-OUT (WxH) <sup>2</sup>	APPROVALS				PAGE
					cULus	EAC	CSA	CE	
<b>Filterfans IP 54</b>									
PF 11.000	1	19 m³/h	230 V AC   24 V DC	92 x 92 mm	●	●	●	●	27
PF 22.000	2	61 m³/h	230 V AC   24 V DC	125 x 125 mm	●	●	●	●	
PF 32.000	3	98 m³/h	230 V AC   24 V DC	177 x 177 mm	●	●	●	●	28
PF 42.500	4	125 m³/h	230 V AC   24 V DC	223 x 223 mm	●	●	●	●	
PF 43.000	4	223 m³/h	230 V AC   24 V DC		292 x 292 mm	●	●	●	●
PF 65.000	6	480 m³/h	230 V AC	●		●	●	●	
PF 66.000	6	640 m³/h	230 V   400/460 V 3 ~	●		●	●	●	
PF 67.000	6	845 m³/h	230 V   400/460 V 3 ~	●	●	●	●	29	
<b>Filterfans IP 55</b>									
PF 22.000	2	56 m³/h	230 V AC   24 V DC	125 x 125 mm	●	●	●	●	31
PF 32.000	3	100 m³/h	230 V AC   24 V DC	177 x 177 mm	●	●	●	●	
PF 42.500	4	145 m³/h	230 V AC   24 V DC	223 x 223 mm	●	●	●	●	32
PF 43.000	4	233 m³/h	230 V AC   24 V DC		●	●	●	●	
PF 65.000	6	505 m³/h	230 V AC	292 x 292 mm	●	●	●	●	33
PF 66.000	6	770 m³/h	230 V   400/460 V 3 ~		●	●	●	●	
PF 67.000	6	925 m³/h	230 V   400/460 V 3 ~		●	●	●	●	
<b>Exhaust Filters</b>									
PFA 10.000	1			92 x 92 mm	●	●	●	●	40
PFA 20.000	2			125 x 125 mm	●	●	●	●	
PFA 30.000	3			177 x 177 mm	●	●	●	●	
PFA 40.000	4			223 x 223 mm	●	●	●	●	
PFA 60.000	6			292 x 292 mm	●	●	●	●	
<b>Slim Line Filterfans</b>									
PF 65.000 SL	6	500 m³/h	230 V AC	292 x 292 mm	●		●	●	34
PF 67.000 SL	6	705 m³/h	230 V   400/460 V 3 ~		●		●	●	
<b>EMC Filterfans</b>									
PF 11.000 EMC	1	19 m³/h	230 V AC   24 V DC	93 x 93 mm	●	●		●	37
PF 22.000 EMC	2	61 m³/h	24 V DC	126,5 x 126,5 mm	●	●		●	
PF 32.000 EMC	3	98 m³/h	230 V AC   24 V DC	178 x 178 mm	●	●		●	
PF 42.500 EMC	4	125 m³/h	230 V AC   24 V DC	224 x 224 mm	●	●		●	
PF 43.000 EMC	4	223 m³/h	230 V AC   24 V DC		●	●		●	
PF 67.000 EMC	6	845 m³/h	230 V   400/460 V 3 ~	292 x 292 mm	●	●		●	
<b>EMC Exhaust Filters</b>									
PFA 10.000 EMC	1			93 x 93 mm	●	●		●	40
PFA 20.000 EMC	2			126,5 x 126,5 mm	●	●		●	
PFA 30.000 EMC	3			178 x 178 mm	●	●		●	
PFA 40.000 EMC	4			224 x 224 mm	●	●		●	
PFA 60.000 EMC	6			292 x 292 mm	●	●		●	
<b>Top mounting Filterfans</b>									
PTF 60.500	6	310 m³/h	230 V AC	291 x 291 mm	●	●		●	35
PTF 60.700	6	646 m³/h			●	●		●	
PTF 61.000	6	1035 m³/h			●	●		●	
<b>Top mounting Exhaust Filter</b>									
PTFA 60.000	6			291 x 291 mm	●	●		●	40
<b>Internal Enclosure Fan and other Accessories</b>									
PEF 180, weather protection hoods, thermostats, hygrostats, filter mats									39
<b>For additional models, options and voltages visit <a href="http://www.pfannenberg.com">www.pfannenberg.com</a> or contact us directly.</b>									

<sup>1</sup> free-blowing

<sup>2</sup> for material thicknesses up to 2 mm

● available ○ pending

# Filterfans IP 54

19–875 m<sup>3</sup>/h

### Optimised airflow

Airflow optimised fins and rotor blades guarantee maximal airflow with minimal energy consumption.

### Efficiency

Filterfans 4.0 can be equipped with an optional thermostat – only operate when cooling is actually necessary.

### Reduced energy consumption

More air, less power consumption.

### Quick installation

The patented 4-corner fastening system allows for tool-free installation in seconds and guarantees a secure hold.

### Easy maintenance

The click mechanism of the cover enables a filter mat replacement in seconds.

### Neutral design

without colour irritations. Perfect harmony of colours with modern machines and plants.

### Compatibility

Filterfans 4.0 can be integrated into existing applications easily since most of the housing cut-outs comply with the Pfannenberg standard.

**Closed frame**  
prevents unfiltered air from penetrating (IP 54).



**Black design**  
Alternative colour for various machine designs.



## FILTERFANS IP 54 19–70 m<sup>3</sup>/h

size  
(PF 11.000)

size  
(PF 22.000)

IP 54  
protection system

tool-less filter mat  
changing

tool-less mounting

black/  
RAL 9011



PRODUCT	PF 11.000		PF 22.000			
ARTICLE NO.	●	11611101055	11611801055	11622101055	11622801055	Unit
ARTICLE NO.	●	11611101050	11611801050	11622101050	11622801050	

DATA					
Rated voltage ±10 %	AC 50   60 Hz		DC		V
	230		24		
Unimpeded airflow	19   24		19		m <sup>3</sup> /h
Airflow rate in combination with exhaust filter	12   14		12		
Power consumption	12   11		2.4		W
Current consumption	0.07   0.06		0.1		
Type of connection	cable, 2-core, length 310 mm		terminal strip		A
Temperature range	-40 ... +55   -40 ... +131				
Service life L <sub>10</sub> (+40 °C)	52500		70000		hrs
Dimensions (X x Y)	109 x 109		145 x 145		
Installation depth (Z2) + Construction height (Z1)	62 + 4		49 + 4		mm
Cut-out dimensions (W x H)	92 x 92		125 x 125		

ACCESSORIES	ARTICLE NUMBER		Page	
Exhaust filter	●	11710001055	11720001055	40
Exhaust filter	●	11710001050	11720001050	40
Spare filter mats	5 pieces	18611600029	18611600030	41
Thermostat			17121000000	39
Hygrostat			17207000000	39
Rainhood in stainless steel			18102000014	39

For additional models, options and voltages visit [www.pfannenberg.com](http://www.pfannenberg.com) or contact us directly.



Performance curves on page 158.



Comprehensive technical documentation such as

- operating instruction, technical data, approvals
- cut-out drawing, CAD | EPLAN | Zuken | WSCAD data

can be retrieved by entering this webcode in the search window on [www.pfannenberg.com](http://www.pfannenberg.com)

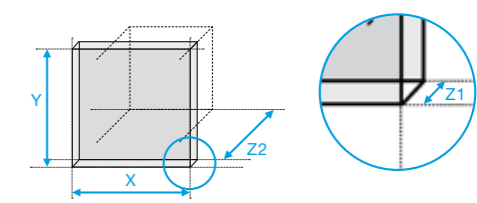

## FILTERFANS IP 54 98–247 m<sup>3</sup>/h



PRODUCT	PF 32.000		PF 42.500		PF 43.000		
ARTICLE NO.	● 11632101055	11632801055	11642101055	11642801055	11643101055	11643801055	Unit
ARTICLE NO.	● 11632101050	11632801050	11642101050	11642801050	11643101050	11643801050	

DATA							
Rated voltage ±10 %	AC 50   60 Hz	DC	AC 50   60 Hz	DC	AC 50   60 Hz	DC	V
	230	24	230	24	230	24	
Unimpeded airflow	98   108	98	125   138	125	223   247	223	m <sup>3</sup> /h
Airflow rate in combination with exhaust filter	73   80	73	93   102	93	201   223	201	
Power consumption	19   18	5	18   17	4.7	45   39	12	W
Current consumption	0.12   0.18	0.21	0.12   0.1	0.2	0.32   0.26	0.5	A
Type of connection	terminal strip	cable, 2-core, length 310 mm	spring type terminal				
Temperature range	-40 ... +55   -40 ... +131						°C   °F
Service life L <sub>10</sub> (+40 °C)	37500	62500	40000	70000	40000	80000	hrs
Dimensions (X x Y)	202 x 202		252 x 252				mm
Installation depth (Z2) + Construction height (Z1)	87 + 6	81 + 6	97 + 6	38 + 6	113 + 6	97 + 6	
Cut-out dimensions (W x H)	177 x 177		223 x 223				

ACCESSORIES	ARTICLE NUMBER		Page
Exhaust filter	● 11730001055	11740001055	40
Exhaust filter	● 11730001050	11740001050	40
Spare filter mats	5 pieces 18611600031	18611600032	41
Thermostat	17121000000		39
Hygrostat	17207000000		39
Rainhood in stainless steel	18102000017		39

For additional models, options and voltages visit [www.pfannenberg.com](http://www.pfannenberg.com) or contact us directly.



Performance curves on page 158–159.



Comprehensive technical documentation such as

- operating instruction, technical data, approvals
- cut-out drawing, CAD | EPLAN | Zuken | WSCAD data

can be retrieved by entering this webcode in the search window on [www.pfannenberg.com](http://www.pfannenberg.com)

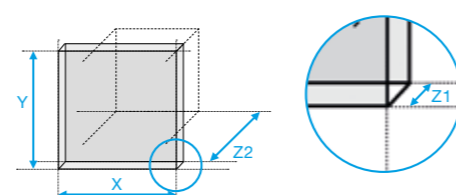

## FILTERFANS IP 54 480–875 m<sup>3</sup>/h



PRODUCT	PF 65.000	PF 66.000		PF 67.000		
ARTICLE NO.	● 11665102055	11666102055	11666022055	11667102055	11667022055	Unit
ARTICLE NO.	● 11665102050	11666102050	11666022050	11667102050	11667022050	

DATA							
Rated voltage ±10 %	AC 50   60 Hz					V	
	230	230	400/460 3 ~	230	400/460 3 ~		
Unimpeded airflow	480   480	640   653		845   875		m <sup>3</sup> /h	
Airflow rate in combination with exhaust filter	370   370	445   445		560   625			
Power consumption	80   100	120   160	120   155	140   197	140   170	W	
Current consumption	0.35   0.45	0.53   0.72	0.26   0.25	0.62   0.86	0.35   0.43	A	
Type of connection	spring type terminal						
Temperature range	-40 ... +55   -40 ... +131						°C   °F
Service life L <sub>10</sub> (+40 °C)	40000						hrs
Dimensions (X x Y)	320 x 320						mm
Installation depth (Z2) + Construction height (Z1)	150 + 7						
Cut-out dimensions (W x H)	292 x 292						

ACCESSORIES	ARTICLE NUMBER		Page
Exhaust filter	● 11760002055		40
Exhaust filter	● 11760002050		40
Spare filter mats	5 pieces 18611600033		41
Thermostat	17121000000		39
Hygrostat	17207000000		39
Rainhood in stainless steel	18102000020		39

For additional models, options and voltages visit [www.pfannenberg.com](http://www.pfannenberg.com) or contact us directly.



Performance curves on page 159–160.

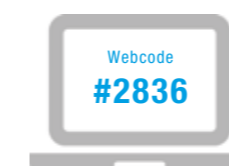

Comprehensive technical documentation such as

- operating instruction, technical data, approvals
- cut-out drawing, CAD | EPLAN | Zuken | WSCAD data

can be retrieved by entering this webcode in the search window on [www.pfannenberg.com](http://www.pfannenberg.com)

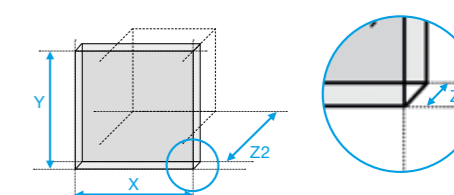

# Filterfans IP 55

56–950 m<sup>3</sup>/h

### Optimised airflow

Airflow optimised fins and rotor blades guarantee maximal airflow with minimal energy consumption.

### Efficiency

Filterfans 4.0 can be equipped with an optional thermostat – only operate when cooling is actually necessary.

### Reduced energy consumption

More air, less power consumption.

### Quick installation

The patented 4-corner fastening system allows for tool-free installation in seconds and guarantees a secure hold.

### IP 55 hose-proof;

suitable for wet, dusty and dirty ambient conditions.

### Easy maintenance

The click mechanism of the cover enables a filter mat replacement in seconds.

### Unrivalled airflow at IP 55

via fluted filter mat. Closed frame prevents unfiltered air from penetrating.

### Compatibility

Filterfans 4.0 can be integrated into existing applications easily since most of the housing cut-outs comply with the Pfannenberg standard.

### Extended life span

3 times longer life span with the fluted filter mats.

### UV resistant

against solar radiation damages.

### Neutral design

without colour irritations. Perfect harmony of colours with modern machines and plants.

### Multiple applications

Appropriate for most indoor and outdoor applications in industrial and rough conditions, i.e. Food & Beverage, Airport, Chemical Plant, Machinery, Wood Processing and many others.

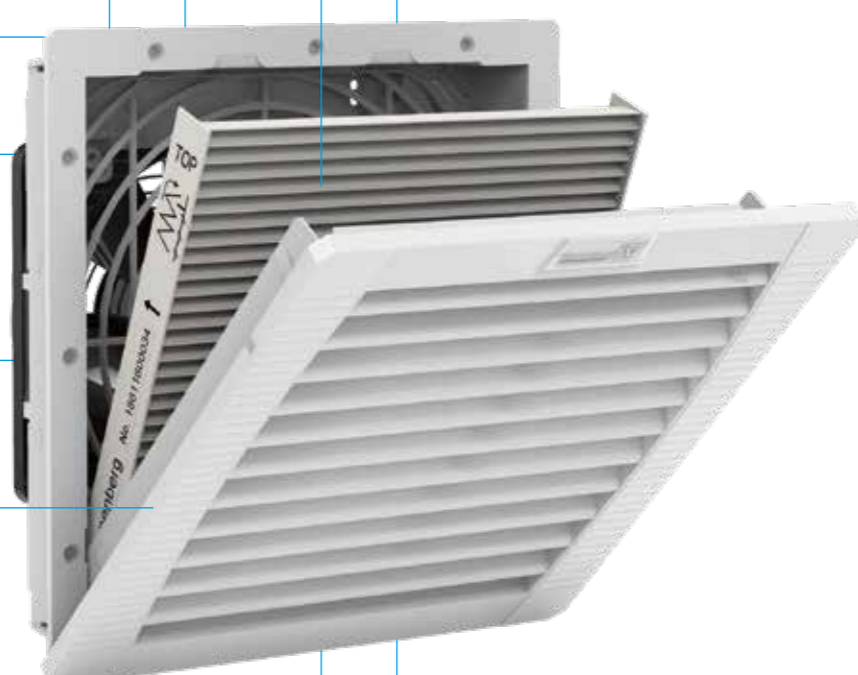

# FILTERFANS IP 55 56–265 m<sup>3</sup>/h

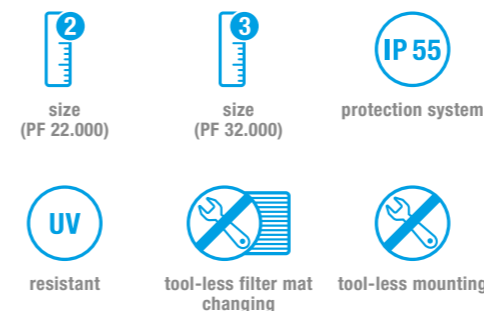

PRODUCT	PF 22.000		PF 32.000		
ARTICLE NO.	11622103055	11622803055	11632103055	11632803055	Unit

DATA					
Rated voltage ±10 %	AC 50   60 Hz	DC	AC 50   60 Hz	DC	
	230	24	230	24	V
Unimpeded airflow	56   64	56	100   110	100	m <sup>3</sup> /h
Airflow rate in combination with exhaust filter	40   46	40	55   64	55	
Power consumption	19   18	5	19   18	5	W
Current consumption	0.12   0.18	0.21	0.12   0.18	0.21	A
Type of connection	terminal strip	cable, 2-core, length 310 mm	terminal strip	cable, 2-core, length 310 mm	
Temperature range	-40 ... +55   -40 ... +131				°C   °F
Service life L <sub>10</sub> (+40 °C)	37500	62500	37500	62500	h
Dimensions (X x Y)	145 x 145		202 x 202		
Installation depth (Z2) + Construction height (Z1)	70 + 5	64 + 5	87 + 6	81 + 6	mm
Cut-out dimensions (W x H)	125 x 125		177 x 177		

ACCESSORIES	ARTICLE NUMBER		Page
Exhaust filter	11720003055	11730003055	40
Spare filter mats	5 pieces	18611600034	41
Thermostat	17121000000		39
Hygrostat	17207000000		39
Rainhood in stainless steel	18102000014	18102000017	39

For additional models, options and voltages visit [www.pfannenberg.com](http://www.pfannenberg.com) or contact us directly.



Performance curves on page 160–161.

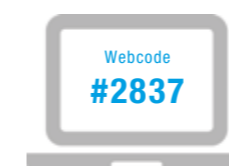

Comprehensive technical documentation such as

- operating instruction, technical data, approvals
- cut-out drawing, CAD | EPLAN | Zuken | WSCAD data

can be retrieved by entering this webcode in the search window on [www.pfannenberg.com](http://www.pfannenberg.com)

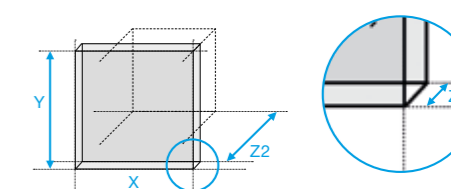

## FILTERFANS IP 55 145–265 m<sup>3</sup>/h



- size
- protection system
- resistant
- tool-less filter mat changing
- tool-less mounting

PRODUCT	PF 42.500		PF 43.000		
ARTICLE NO.	11642103055	11642803055	11643103055	11643803055	Unit

DATA					
Rated voltage ±10 %	AC 50   60 Hz	DC	AC 50   60 Hz	DC	V
	230	24	230	24	
Unimpeded airflow	145   160	145	233   265	233	m <sup>3</sup> /h
Airflow rate in combination with exhaust filter	109   113	109	180   207	180	
Power consumption	19   18	4,7	18   17	12	W
Current consumption	0.12   0.18	0.2	0.12   0.1	0.5	A
Type of connection	spring type terminal				
Temperature range	-40 ... +55   -40 ... +131				°C   °F
Service life L <sub>10</sub> (+40 °C)	40000	70000	40000		h
Dimensions (X x Y)	252 x 252				mm
Installation depth (Z2) + Construction height (Z1)	97 + 6		113 + 6	97 + 6	
Cut-out dimensions (W x H)	223 x 223				

ACCESSORIES	ARTICLE NUMBER	Page
Exhaust filter	11740003055	40
Spare filter mats 5 pieces	18611600036	41
Thermostat	17121000000	39
Hygrostat	17207000000	39
Rainhood in stainless steel	18102000017	39

For additional models, options and voltages visit [www.pfannenberg.com](http://www.pfannenberg.com) or contact us directly.



Performance curves on page 161.



Comprehensive technical documentation such as

- operating instruction, technical data, approvals
- cut-out drawing, CAD | EPLAN | Zuken | WSCAD data

can be retrieved by entering this webcode in the search window on [www.pfannenberg.com](http://www.pfannenberg.com)

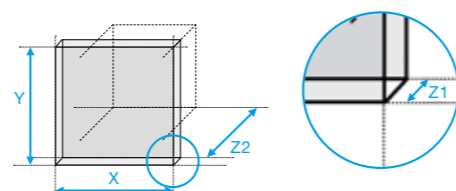

## FILTERFANS IP 55 505–950 m<sup>3</sup>/h



- size
- protection system
- resistant
- tool-less filter mat changing
- tool-less mounting
- cut-out compatible to DTFI 9021

PRODUCT	PF 65.000	PF 66.000		PF 67.000		
ARTICLE NO.	11665103055	11666103055	11666023055	11667103055	11667023055	Unit

DATA						
Rated voltage ±10 %	AC 50   60 Hz					V
	230	400/460 3 ~	230	400/460 3 ~		
Unimpeded airflow	505   505	770   785	925   950			m <sup>3</sup> /h
Airflow rate in combination with exhaust filter	380   380	490   501	570   625			
Power consumption	80   100	120   160	120   155	140   197	140   170	W
Current consumption	0.35   0.45	0.53   0.72	0.26   0.25	0.62   0.86	0.35   0.43	A
Type of connection	spring type terminal					
Temperature range	-40 ... +55   -40 ... +131					°C   °F
Service life L <sub>10</sub> (+40 °C)	40000					h
Dimensions (X x Y)	320 x 320					mm
Installation depth (Z2) + Construction height (Z1)	150 + 7					
Cut-out dimensions (W x H)	292 x 292					

ACCESSORIES	ARTICLE NUMBER	Page
Exhaust filter	11760003055	40
Spare filter mats 5 pieces	18611600037	41
Thermostat	17121000000	39
Hygrostat	17207000000	39
Rainhood in stainless steel	18102000020	39

For additional models, options and voltages visit [www.pfannenberg.com](http://www.pfannenberg.com) or contact us directly.



Performance curves on page 162.



Comprehensive technical documentation such as

- operating instruction, technical data, approvals
- cut-out drawing, CAD | EPLAN | Zuken | WSCAD data

can be retrieved by entering this webcode in the search window on [www.pfannenberg.com](http://www.pfannenberg.com)

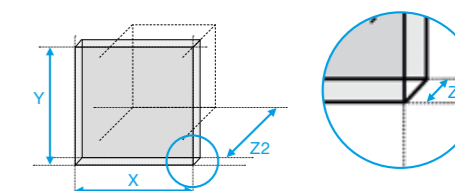

## SLIM LINE FILTERFANS 500–725 m<sup>3</sup>/h

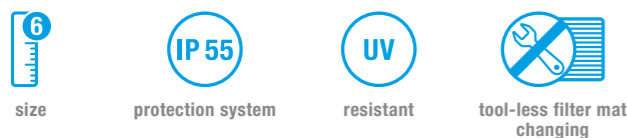

More space in the enclosure.  
High performance at low installation depth.  
No collision with built-in components.  
Life span  
4 times longer life span of filter mat.

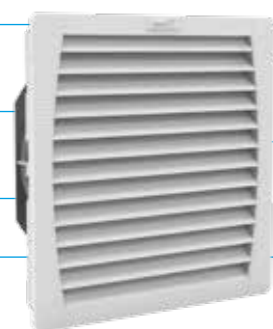

**Maintenance**  
Tool-less filter mat exchange in seconds.  
**IP 55 hose-proof**  
increased protection for humid environment.  
**UV resistant**  
for outdoor and indoor.

PRODUCT	PF 65.000 SL	PF 67.000 SL		
ARTICLE NO.	11675103055	11677103055	11677023055	Unit

DATA				
Rated voltage ±10 %	AC 50   60 Hz			V
	230		400/460 3 ~	
Unimpeded airflow	500   550	705   725		m <sup>3</sup> /h
Airflow rate in combination with exhaust filter	345   423	530   580		
Power consumption	64   80	115   165	110   165	W
Current consumption	0.29   0.35	0.51   0.7	0.2   0.23	A
Type of connection	screw terminal			
Temperature range	-40 ... +55   -40 ... +131			°C   °F
Service life L <sub>10</sub> (+ 40 °C)	40000			hrs
Dimensions (X x Y)	320 x 320			mm
Installation depth (Z2) + Construction height (Z1)	124 + 7	127 + 7		
Cut-out dimensions (W x H)	292 x 292			

ACCESSORIES	ARTICLE NUMBER		Page
Exhaust filter	11760003055		40
Spare filter mats	5 pieces	18611600037	41
Thermostat	17121000000		39
Hygrostat	17207000000		39
Rainhood in stainless steel	18102000020		39

For additional models, options and voltages visit [www.pfannenberg.com](http://www.pfannenberg.com) or contact us directly.

Performance curves on page 164.

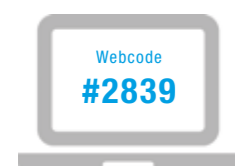

Comprehensive technical documentation such as

- operating instruction, technical data, approvals
- cut-out drawing, CAD | EPLAN | Zuken | WSCAD data

can be retrieved by entering this webcode in the search window on [www.pfannenberg.com](http://www.pfannenberg.com)

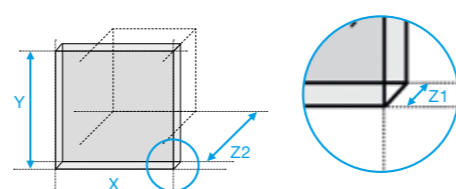

## TOP MOUNTING FILTERFANS 350–1035 m<sup>3</sup>/h



3 performance classes in only one installation cut-out.  
Natural air convection is supported.  
Tool-less mounting.



Can be operated with or without a filter mat according to the ambient conditions.  
Sucking fan for an even circulation in the whole electrical enclosure.

PRODUCT		PTF 60.500	PTF 60.700	PTF 61.000	PTFA 60.000	
ARTICLE NO.	IP 54	11685101055	11687102055	11681102055	11786001055	Unit
ARTICLE NO.	IP 33	11685100055	11687100055	11681100055	11786000055	

DATA						
Rated voltage ±10 %	AC 50   60 Hz					V
	230					
Unimpeded airflow	IP 54	310	646	1035	–	m <sup>3</sup> /h
Airflow rate in combination with exhaust filter	IP 54	210	360	570	–	
Power consumption		4 x 28   29	80   100	120   160	–	W
Current consumption		4 x 0.2   0.2	0.35   0.45	0.53   0.72	–	A
Type of connection	terminal strip					–
Temperature range	-15 ... +55   +5 ... +131					°C   °F
Service life L <sub>10</sub> (+25 °C)		approx. 50000	approx. 40000	–	–	h
Dimensions (X x Y)		436 x 436	470 x 470	436 x 436	–	mm
Installation depth (Z2) + Construction height (Z1)		34 + 72	57 + 95	34 + 72	–	
Cut-out dimension (W x D)		291 x 291			–	

ACCESSORIES	ARTICLE NUMBER			Page	
Spare filter mats	20 pieces	18611600124	18611600143	18611600124	41
Thermostat	17121000000			39	
Hygrostat	17207000000			39	

For additional models, options and voltages visit [www.pfannenberg.com](http://www.pfannenberg.com) or contact us directly.

Performance curves on page 163.

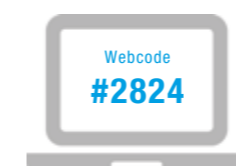

Comprehensive technical documentation such as

- operating instruction, technical data, approvals
- cut-out drawing, CAD | EPLAN | Zuken | WSCAD data

can be retrieved by entering this webcode in the search window on [www.pfannenberg.com](http://www.pfannenberg.com)

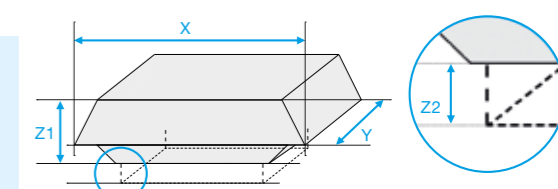

# EMC Filterfans

**In most cases, industrial control cabinets are made of sheet steel.** As a result of this choice of material, the control cabinet provides very good protection against electromagnetic radiation. This protection is compromised by the cut-out in the cabinet for the filterfan. Since the filterfan is usually made of plastic, electromagnetic waves can enter and escape in both directions through the opening. EMC filterfans “close” this hole.

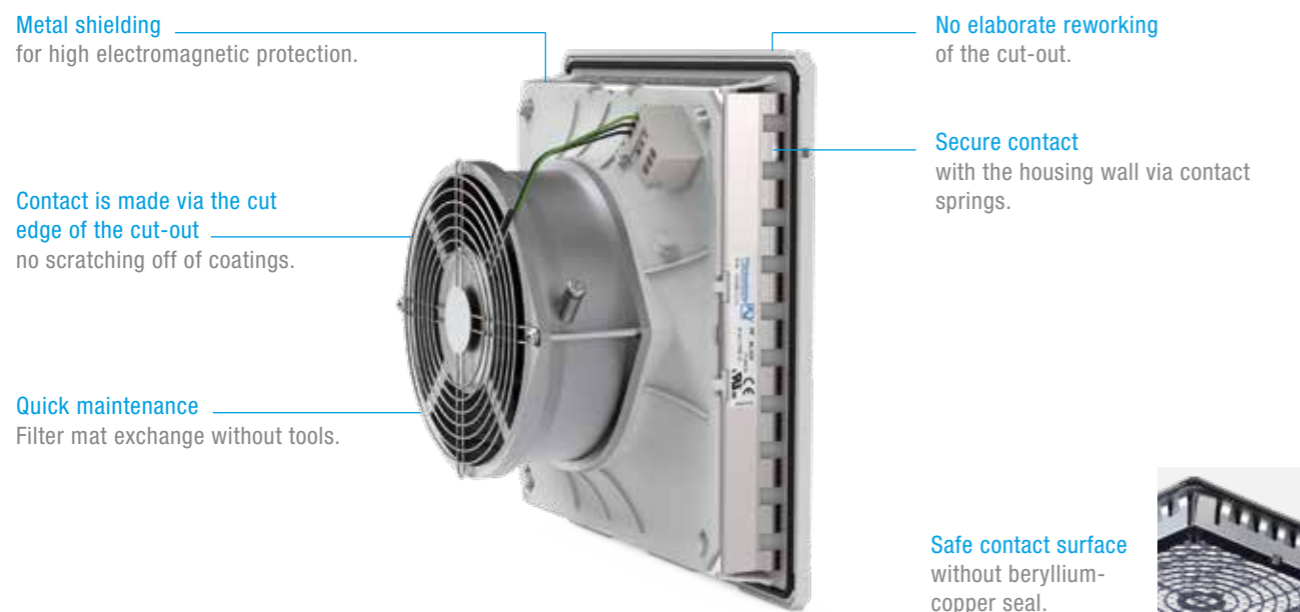

Pfannenberg uses a very effective, safe and environmentally friendly method for its EMC filterfan model. As a result, the protective effect of the control cabinet is restored even though filterfans are used. The EMC protection of the control cabinet is, as a result, guaranteed in both directions of the electromagnetic radiation. The components in the cabinet do not disturb the external environment and disturbance sources outside the cabinet do not disturb the components on the inside.

Pfannenberg's EMC filterfans reach the following attenuation values:  
 Damping at 30 MHz approx. 71 dB  
 Damping at 400 MHz approx. 57 dB

You can find the result charts of all shield attenuation measurements of Pfannenberg's filterfans and exhaust filters on [www.pfannenberg.com](http://www.pfannenberg.com); please enter Webcode #2314 in the search window.

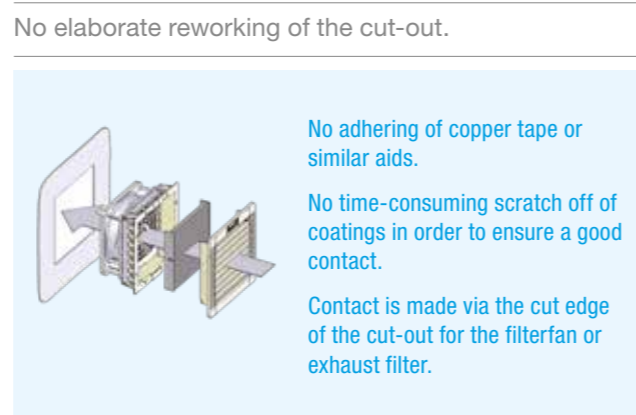

# EMC FILTERFANS 19–108 m<sup>3</sup>/h

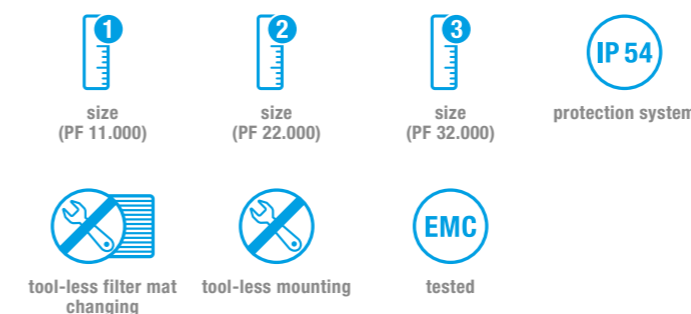

PRODUCT	PF 11.000 EMC		PF 22.000 EMC		PF 32.000 EMC		Unit
ARTICLE NO.	11811101055	11811801055	11822101055	11822801055	11832101055	11832801055	

DATA	PF 11.000 EMC		PF 22.000 EMC		PF 32.000 EMC		
Rated voltage ±10 %	AC 50   60 Hz 230	DC 24	AC 50   60 Hz 230	DC 24	AC 50   60 Hz 230	DC 24	V
Unimpeded airflow	19   24	19	61   70	61	98   108	98	m <sup>3</sup> /h
Airflow rate in combination with exhaust filter	12   14	12	38   42	38	73   80	73	
Power consumption	19   18	2.4	19   18	5	19   18	5	W
Current consumption	0.12   0.18	0.1	0.12   0.18	0.21	0.12   0.18	0.21	A
Type of connection	cable, 2-core, length 310 mm		terminal strip	cable, 2-core, length 310 mm	terminal strip	cable, 2-core, length 310 mm	
Temperature range	-40 ... +55   -40 ... +131						°C   °F
Service life L <sub>10</sub> (+40 °C)	52500	70000	37500	62500	37500	62500	h
Dimensions (X x Y)	109 x 109		145 x 145		202 x 202		
Installation depth (Z2) + Construction height (Z1)	62 + 4	49 + 4	70 + 5	64 + 5	87 + 6	81 + 6	mm
Cut-out dimensions (W x H)	93 x 93		126,5 x 126,5		178 x 178		

ACCESSORIES	ARTICLE NUMBER			Page
Exhaust filter	11910001055	11920001055	11930001055	40
Spare filter mats 5 pieces	18611600029	18611600030	18611600031	41
Thermostat	17121000000			39
Hygrostat	17207000000			39
Rainhood in stainless steel	18102000014		18102000017	39

For additional models, options and voltages visit [www.pfannenberg.com](http://www.pfannenberg.com) or contact us directly.



Performance curves on page 158.

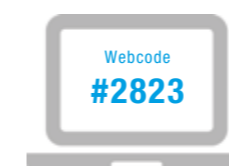

Comprehensive technical documentation such as  
 • operating instruction, technical data, approvals  
 • cut-out drawing, CAD | EPLAN | Zuken | WSCAD data  
 can be retrieved by entering this webcode in the search window on [www.pfannenberg.com](http://www.pfannenberg.com)

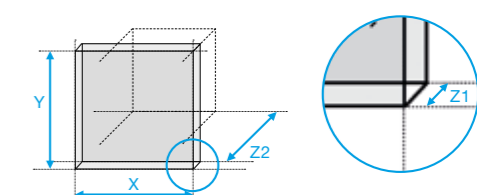

## EMV-FILTERLÜFTER 125–875 m<sup>3</sup>/h

size  
(PF 43.000)

size  
(PF 65.000)

protection system

tool-less filter mat  
changing

tool-less mounting

tested

cut-out compatible  
to DTFI 9021  
(PF 67.000)



PRODUCT	PF 42.500 EMC		PF 43.000 EMC		PF 67.000 EMC		
ARTICLE NO.	11842101055	11842801055	11843101055	11843801055	11867022055	11867102055	Unit
<b>DATA</b>							
Rated voltage ±10 %	AC 50   60 Hz 230	DC 24	AC 50   60 Hz 230	DC 24	AC 50   60 Hz 400 3~   460 3~ 230		V
Unimpeded airflow	125   138	125	223   247	223	845   875		m <sup>3</sup> /h
Airflow rate in combination with exhaust filter	93   102	93	201   223	201	560   625		
Power consumption	18   17	4.7	45   39	12	140   170	140   197	W
Current consumption	0.12   0.1	0.2	0.32   0.26	0.5	0.35   0.43	0.62   0.86	A
Type of connection	spring type terminal						
Temperature range	-40 ... +55   -40 ... +131						°C   °F
Service life L <sub>10</sub> (+40 °C)	40000	70000	40000	80000	40000		h
Dimensions (X x Y)	252 x 252				320 x 320		mm
Installation depth (Z2) + Construction height (Z1)	97 + 6		113 + 6	97 + 6	150 + 7		
Cut-out dimensions (W x H)	224 x 224				292 x 292		

ACCESSORIES	ARTICLE NUMBER		Page
Exhaust filter	11940001055		40
Spare filter mats 5 pieces	18611600032		41
Thermostat	17121000000		39
Hygrostat	17207000000		39
Rainhood in stainless steel	18102000017	18102000020	39

For additional models, options and voltages visit [www.pfannenberg.com](http://www.pfannenberg.com) or contact us directly.



Performance curves on page 159–160.



Comprehensive technical documentation such as

- operating instruction, technical data, approvals
- cut-out drawing, CAD | EPLAN | Zuken | WSCAD data

can be retrieved by entering this webcode in the search window on [www.pfannenberg.com](http://www.pfannenberg.com)

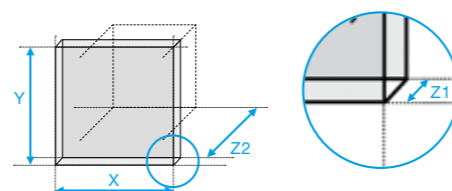

## Accessories

### INTERNAL ENCLOSURE FAN

- For long rows of electrical enclosures which are only cooled with one unit.
- Distribution of the cold air in the electrical enclosure.
- Robust – steel housing and bracket.
- Variable – air stream can with adjustable bracket be guided to any direction.
- Slim – even suitable for limited space.



PRODUCT	PEF 180		
ARTICLE NO.	18110000000	18110000002	Unit
<b>DATA</b>			
Rated voltage ±10 %	AC 50   60 Hz 230	DC 24	V

### WEATHER PROTECTION HOOD

- Weather protection hood NEMA 3R/4 in VA or powder-coated.
- The mounting bracket can easily be installed to the enclosure around the existing cut-out.



PRODUCT	WEATHER PROTECTION HOOD			
ARTICLE NO.	VA	18102000014	18102000017	18102000020
ARTICLE NO.	RAL 7035	18102000013	18102000016	18102000019
<b>SUITABLE FOR...</b>				
Installation size		1   2	3   4	6

### THERMOSTAT AND HYGROSTAT

In combination with thermostats and hygrometers from the FLZ series, Pfannenberg filterfans additionally achieve savings on energy, materials and time – plus a significantly longer service life. This results in an optimised environmental balance as well as greater reliability of your production process. Suitable for all Pfannenberg filterfans.



PRODUCT	FLZ 530	FLZ 543	FLZ 600	FLZ 610
ARTICLE NO.	17121000000	17143000000	17207000000	17218100000
<b>DATA</b>				
Version	Thermostat 0–60 °C	Twin Thermostat 0–60 °C	Hygrostat 40–90 % R.H.	Thermostat/Hygrostat 0–60 °C / 40–90 % R.H.

## Accessories

### EXHAUST FILTERS for all PF filterfans

- Same design as the PF series filterfans.
- Snap fastener developed and patented by Pfannenberg.
- Door mounting without screws in accordance with VDE 0113 (EN 60204).
- Simple filter mat exchange during operation.
- With integrated foam seal to enclosure.



#### EXHAUST FILTERS

Grey (RAL 7035) for all PF filterfans.

PRODUCT	CUT-OUT	ARTICLE NUMBER (IP 54)	ARTICLE NUMBER (IP 55)
PFA 10.000	92 x 92 mm	11710001055	–
PFA 20.000	125 x 125 mm	11720001055	11720003055
PFA 30.000	177 x 177 mm	11730001055	11730003055
PFA 40.000	223 x 223 mm	11740001055	11740003055
PFA 60.000	292 x 292 mm	11760002055	11760003055
PFA 10.000 EMC	93 x 93 mm	11910001055	
PFA 20.000 EMC	126.5 x 126.5 mm	11920001055	
PFA 30.000 EMC	178 x 178 mm	11910001055	
PFA 40.000 EMC	224 x 224 mm	11940001055	
PFA 60.000 EMC	292 x 292 mm	11960002055	

#### EXHAUST FILTERS

black (RAL 9011) for all PF filterfans.

PRODUCT	CUT-OUT	ARTICLE NUMBER (IP 54)
PFA 10.000	92 x 92 mm	11710001050
PFA 20.000	125 x 125 mm	11720001050
PFA 30.000	177 x 177 mm	11730001050
PFA 40.000	223 x 223 mm	11740001050
PFA 60.000	292 x 292 mm	11760002050



#### EXHAUST FILTERS

Grey (RAL 7035) for all PTF filterfans.

PRODUCT	CUT-OUT	ARTICLE NUMBER (IP 54)
PTFA 60.000	291 x 291 mm	11786001055



### FILTER MATS for filterfans and exhaust filters



IP 54



IP 55

#### SPARE FILTER MATS

for filterfans of the 4<sup>th</sup> Generation.

SUITABLE FOR...	ARTICLE NUMBER <sup>1</sup> (IP 54)	DIMENSIONS
Installation size 1	18611600029	87 x 87 mm
Installation size 2	18611600030	119 x 119 mm
Installation size 3	18611600031	170 x 170 mm
Installation size 4	18611600032	216 x 216 mm
Installation size 6	18611600033	284 x 284 mm

SUITABLE FOR...	ARTICLE NUMBER <sup>1</sup> (IP 55)	DIMENSIONS
Installation size 2	18611600034	116 x 108 mm
Installation size 3	18611600035	166 x 156 mm
Installation size 4	18611600036	212 x 200 mm
Installation size 6	18611600037	279 x 264 mm

<sup>1</sup> set with 5 pieces

#### SPARE FILTER MATS

for top mounting filterfans.

SUITABLE FOR...	ARTICLE NUMBER <sup>1</sup> (IP 54)	DIMENSIONS
PTF 60.500   PTFA 60.000	18611600124	290 x 70 mm
PTF 60.700   PTF 61.000	18611600143	290 x 95 mm

<sup>1</sup> package for 5 filterfans

#### SPARE FILTER MATS

for filterfans of the 3<sup>rd</sup> Generation.

SUITABLE FOR...	ARTICLE NUMBER <sup>1</sup> (IP 54)	DIMENSIONS
PF 1.000   PFA 1.000	18611600029	87 x 87 mm
PF 2.000   PFA 2.000	18611600066	115 x 115 mm
PF 2.500   3.000   3.000 SL   PFA 2.500/3.000	18611600074	210 x 210 mm
PF 5.000   6.000   7.000   6.000 SL2   6.500 SL1   PFA 5.000   6.000   7.000	18611600081	277 x 277 mm

<sup>1</sup> set with 5 pieces

# Efficient cooling.

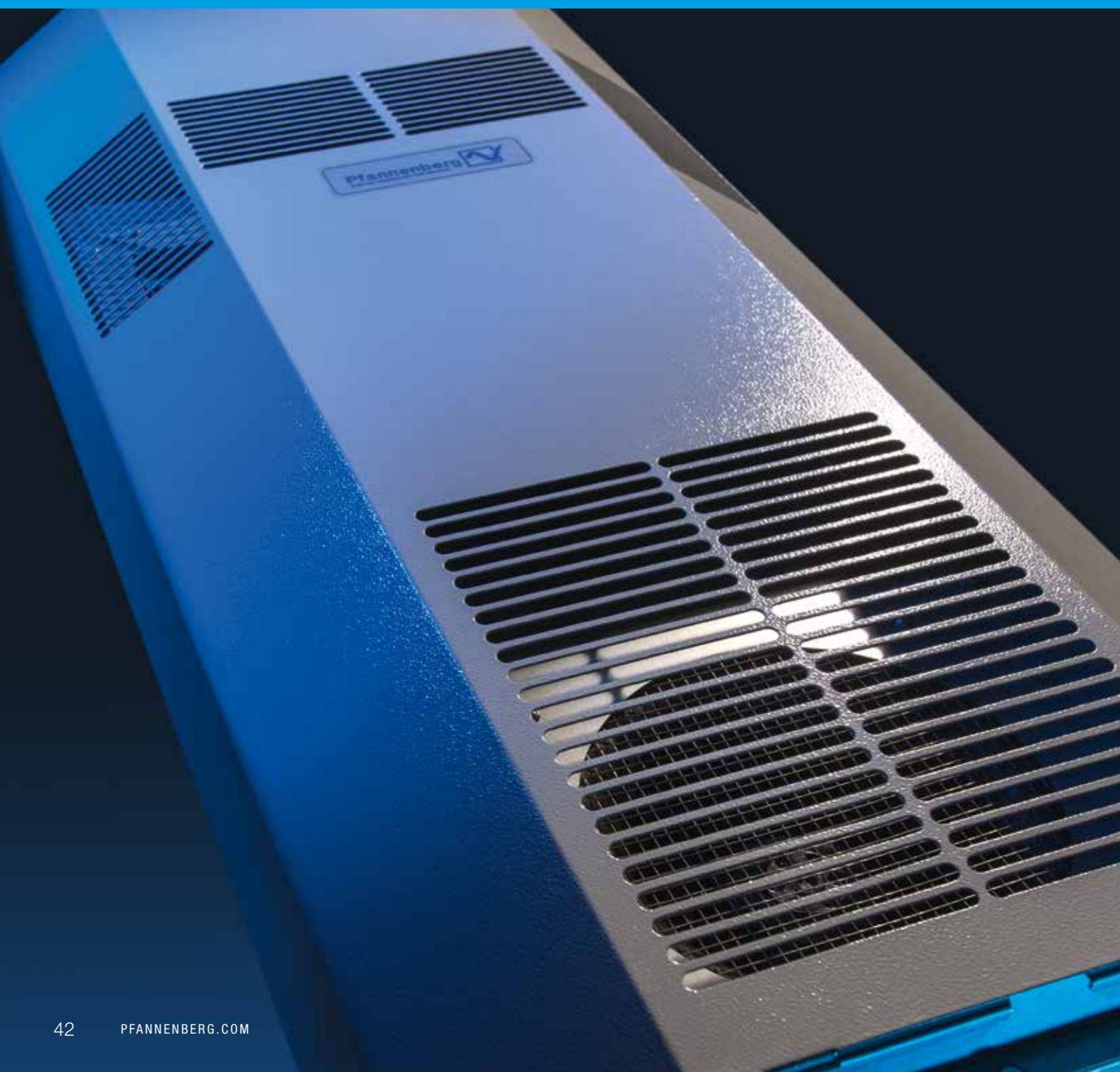

## ECOOL Air/Air Heat Exchangers from the PAS series.

Using the ambient air for the thermal management of the enclosure is the most economical and energy efficient type of cooling. In many applications the ambient air is contaminated by dust, liquid or gases, so that components which are integrated in the enclosure can be damaged when contact occurs. The use of a filterfan is therefore no longer possible.

The Pfannenberg air/air heat exchangers make the ideal solution for these application areas. Due to the integrated heat exchangers, a complete separation of the internal and external air flow is possible. The interior of the enclosure is thus hermetically separated from the atmosphere. Harmful dust and fluids can't cause any damage to the integrated components. The **ECOOL** air/air heat exchangers are thus an alternative to filterfans.

The robust steel construction of the air/air heat exchangers makes their operation in harsh industrial environments possible. According to our **ECOOL** motto, special focus has been placed on maintenance friendliness. Assembly and maintenance have been reduced to a uniquely low amount of time. Energy efficiency and maintenance friendliness form the optimal basis for process safety, reliability and cost advantages.

Protecting man, machine and the environment.

## Cut-out compatibility with active cooling units from the DTS series.

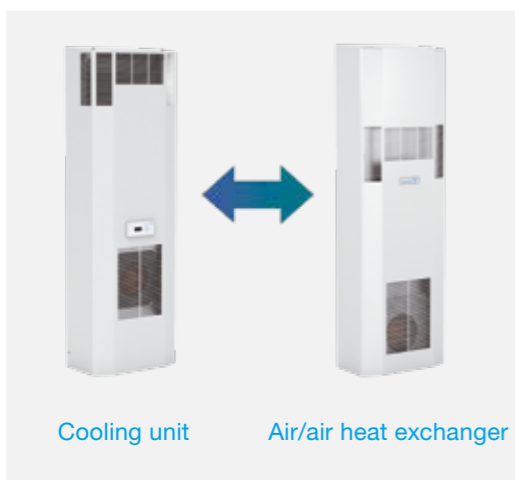

Components in the enclosure are often updated and the requirements to thermal management change. An air/air heat exchanger which was previously the optimal solution is not suitable any more. The refitting of an active **ECOOL** cooling unit can be carried out easily and without problems, because the units have the same cut-out dimensions. Thus, the process stability is also ensured after extensive modifications.

### The advantages at a glance:



- Tool-free retrofit of filter adapter.
- Tool-free filter change.
- Change filter in less than one minute.



- Temperature adjusting occurs via the mechanical thermostat.
- Additional alarm thermostat allows for the ideal regulation of the alarm limit.

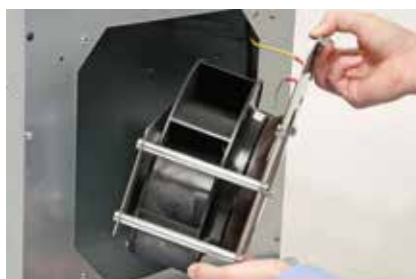

- Maintenance friendly.
- All fans are easily accessible from the outside.
- Not necessary to open the enclosure.
- Exchange of the fan in less than 6 minutes.
- Secure selection via PSS.

## ECOOL Air/Air Heat Exchangers at a glance

**PAS** for outer mounting on the door or side

TYPE	SPECIFIC COOLING CAPACITY	RATED VOLTAGE	DIMENSIONS (HxWxD)	APPROVALS	PAGE
				CE	
<b>PAS Air/Air Heat Exchangers</b>					
PAS 6043	20 W/K	230 V	618 x 380 x 212 mm	●	47
PAS 6133	65 W/K		937 x 410 x 199 mm	●	
PAS 6203	100 W/K		1555 x 485 x 252 mm	●	
<b>Accessories</b>					
Internal enclosure fan		230 V			39

For additional models, options and voltages visit [www.pfannenberg.com](http://www.pfannenberg.com) or contact us directly.

● available ○ pending



# PAS 6000

## ECOOL Air/Air Heat Exchangers

20–100 W/K

Door or side mounting; in the event of limited space in the cabinet; the routing of cold air to the important components in the cabinet is retained

**Highest variability**  
due to cut-out compatibility for 5 performance classes and to Pfannenberg cooling units and air/water heat exchangers.

**Large distance between intake and exhaust vents**  
for safe air circulation and elimination of hot spots.

**Optional pre-filter**  
upgradable with aluminium, fleece or fluted filter, for applications with heat exchangers in different ambient conditions.



**Integrated thermostat**  
for temperature control; additional thermostat for excessive temperature warning and maintenance-free.

**Service friendly**  
due to direct access to the fans, thus 80 % shorter repair times.

## AIR/AIR HEAT EXCHANGERS 20–100 W/K

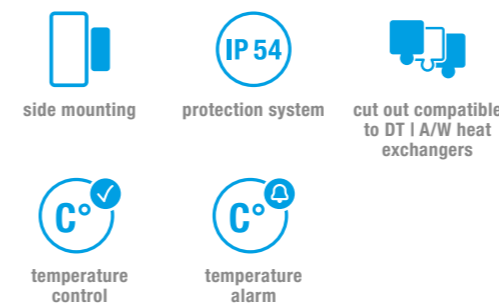

PRODUCT	PAS 6043	PAS 6133	PAS 6203	Unit
ARTICLE NO.	12981111055	12982411055	12983611055	

DATA					
Rated voltage ±10 %	AC 50   60 Hz				
	230			V	
Specific cooling capacity	20	65	100	W/K	
Power consumption	50   56	310   420		W	
Current consumption	0.25   0.26	1.3   1.8	1.3   1.7	A	
Starting current	0.7   0.8	3.6   3.7	3.5   3.3		
Unimpeded airflow (free flow)	internal	240   280	1175   1300	m³/h	
Type of connection	spring-type terminal included with plug				
Ambient temperature range	-25 ... +55				
Control range (adjustable)	control	+20 ... +55   factory setting +35			°C
	alarm	+30 ... +65   factory setting +45			
Dimensions (X x Y x Z)	380 x 618 x 212	410 x 937 x 199	485 x 1555 x 252	mm	
Weight (net)	15.5	24.9	46.3	kg	
Degrees of protection according to EN 60529	IP 54	towards the electrical enclosure if used as intended by the manufacturer			
Design	housing	galvanised sheet steel			
	cover	galvanised; electrostatically powder coated (200 °C)			
Colour (cover)	RAL 7035   different colours available on request				

ACCESSORIES	ARTICLE NUMBER			Page
Filter adapter (RAL 7035)	18060200000	18060200001	18310000151	83
Fleece filter (5 pieces)	18061600000	18061600001	18300000147	83
Internal enclosure fan	18110000000			39

For additional models, options and voltages visit [www.pfannenberg.com](http://www.pfannenberg.com) or contact us directly.



Performance curves on page 164–165.

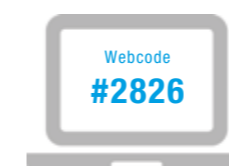

Comprehensive technical documentation such as

- operating instruction, technical data, approvals
- cut-out drawing, CAD | EPLAN | Zuken | WSCAD data

can be retrieved by entering this webcode in the search window on [www.pfannenberg.com](http://www.pfannenberg.com)

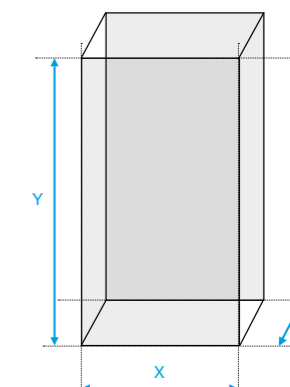

# Designed for the future.



Cooling units designed to meet all future requirements.

Being part of the process chain, we are well aware that our products also have to meet increasing expectations. This is why our active cooling units are compatible with all types of electrical enclosures and can be adapted to any system design. Worldwide, they deliver smooth process control sequences – with maximum reliability and ease of servicing plus innovative technologies.

#### **Product lines for all space conditions.**

The cooling units in our DTI and DTS product lines give you flexibility in the use of the available space. They satisfy all requirements for partially recessed (DTI) and side mounted (DTS) installation. Units in our DTT product line require even less space. Top-mounted cooling units provide the perfect solution for the most limited of spaces and 100 % protection against condensate.

#### **Units for every requirement.**

All three product lines include innovative units from our energy-efficient and powerful **ECOOL** series for you to choose from. We offer the proven compact series 9000 models in the DTI and DTS versions. The robust series 3000 provides side mounted units for the food industry, automotive and outdoor use.

Protecting man, machine and the environment.

## Selecting the right Cooling Unit series.

Pfannenberg's cooling units are available in 4 different series. The design concepts make it possible to select the appropriate cooling unit for the many different applications and ambient conditions.

### Mounting options: DTI, DTS and DTT.



#### DTI

Cooling unit for the partially recessed side or door mounting, extremely quick installation by one person in less than 3 minutes.

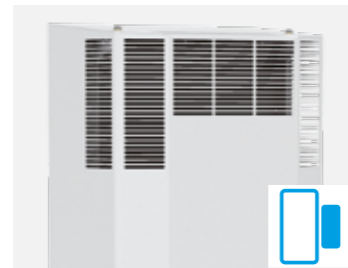

#### DTS

Cooling unit for side or door mounting. For cases when there is no available space for the cooling unit inside the control cabinet.



#### DTT

Cooling unit with 100 % condensate safety for the space-saving installation on the top of the control cabinet.



### 6000 DTT ECOOL series: for top mounted applications.

- Space-saving installation on top of the control cabinet. Emergency escape routes and logistic paths are kept clear. Expensive storage space is saved.
- Perfect protection against mechanical damage in running production operation because it is "out of reach" of fork lift trucks and other vehicles.
- DTT cooling units fit on cabinets of all manufacturers.
- 100 % protection against condensate due to patented "warped" construction.

More on page 66.



### 9000 DTI/DTS series: for basic applications.

- Cooling units in proven industrial version.
- Previous series to the latest 6000 units.
- Technically simple version with inexpensive standard controller.

More on page 70.



### 3000 DTS series: for extra harsh environments.

- The series has similar performances to the 6000 and 9000 series and is suitable for narrower cut-out dimensions. For example, at the side of less deep cabinets or on narrower doors.
- Robust US design with NEMA ratings 12, 3R/4 and 4/4x.
- Suitable for simple indoor and more demanding outdoor and wash-down applications.
- UL listed certification.

More on page 74.

### 6000 DTI/DTS ECOOL series: progressive and energy efficient.

- State of the art cooling unit series for side mounting according to the latest developments in technology.
- Especially energy efficient with a high EER (Energy Efficiency Ratio).
- Service friendly, easy to exchange fan and circuit board.
- Outside surface easy to clean.
- Optional filter adapter available for 3 different filter media for all industrial environments.
- Cut-out compatible to the older 9000 series.
- High air volume flow for the safe cooling of hot-spots.
- Cut-out compatible to 6000 air/water and air/air heat exchangers.
- In Multi Controller version:
  - equipped with a service interface for the integration in the machine control – ready for IoT: Machine to Machine.
  - 2nd temperature sensor enables the internal fan to be switched off safely.
  - Multi Master instead of the master/slave function: Cooling units continue cooling even when one breaks down.

More on page 60.



Small size

# Advantages of the **ECOOL** Cooling Unit Series.

## New Filter Adapter.



- Optional adapter for multiple use and all filter inserts.
- Optional filter inserts (aluminium, fleece or fluted filter inserts) depending on the environmental conditions/application.
- Patented fluted filter mats extend the service intervals by 300 %.
- Tool-less installation and tool-less filter replacement.
- Filter replacement in less than one minute.
- Filter adapter available in several colours.

## Controlled Energy Efficiency.



- Pfannenberg „Multi Controller“ (MC) has now been upgraded with the energy savings mode (ESM) as a standard feature (DTI/DTS 6000 series).
- Internal fan switches off when no temperature increase is registered; condensate evaporator will then be deactivated.
- Cooling mode starts automatically upon exceeding the required cabinet temperature.
- Additional temperature probe for precise measurement of the internal cabinet temperature and to ensure correct operation of the energy savings mode.
- No intermediate start-up of the internal fan necessary for temperature monitoring of the cabinet.
- Fan's length of life is significantly longer.

## New Energy Saving Mode with additional temperature probe

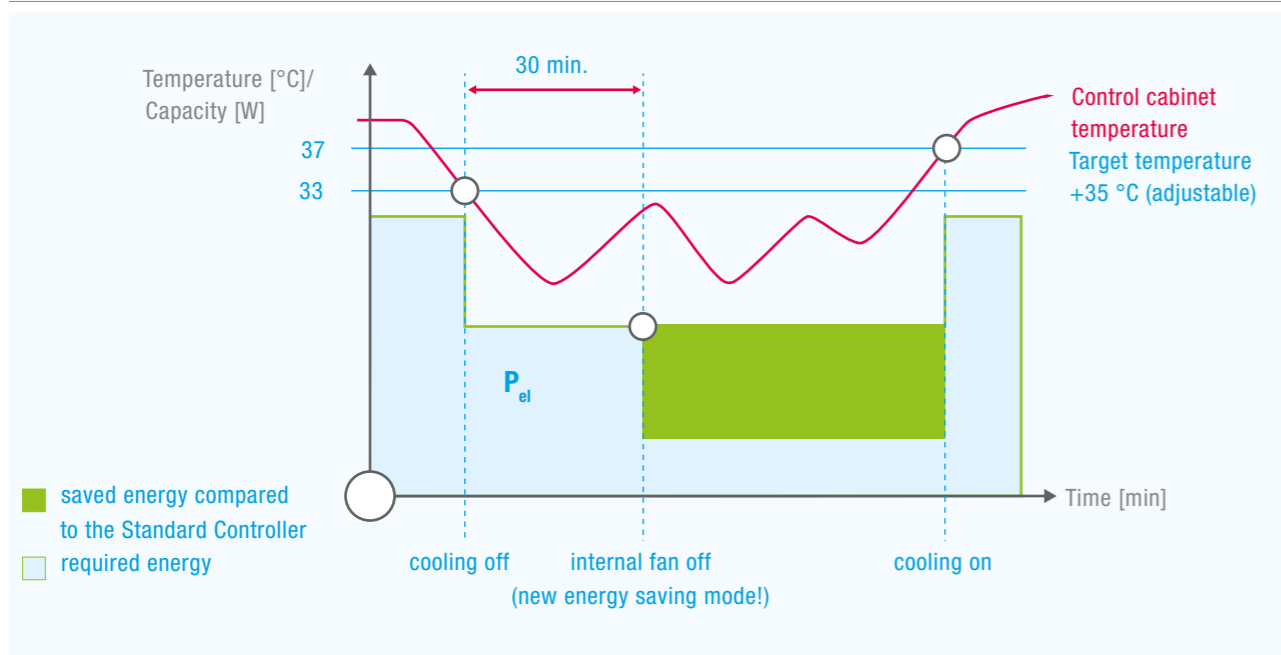

# Effective Cost Savings with Pfannenberg **ECOOL** Cooling Units.

Take a small business with 5 cooling units, which operate in two shifts as an example. In comparison to the **ECOOL** DTI 6401 with a 2,000 W cooling capacity and a comparable unit available on the market.

## Energy savings comparison

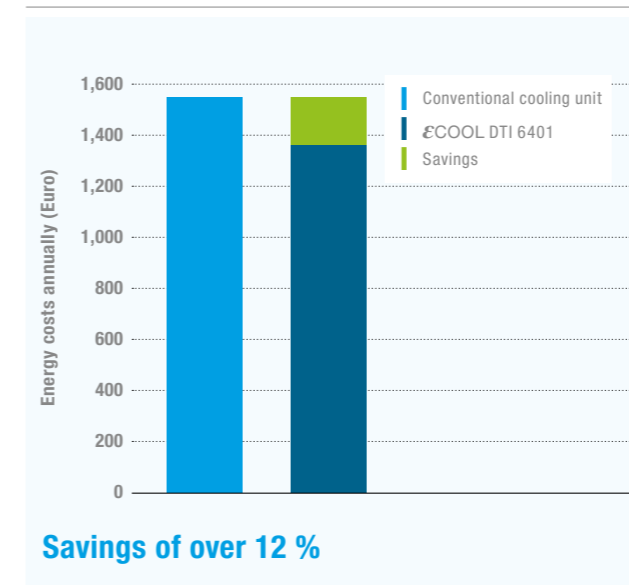

The **ECOOL** DTI 6401 saves 12 % in energy costs in comparison to conventional cooling units.

## Basic parameter for energy comparison

Uptime at full performance	70 %
Uptime at partial performance	30 %
Total uptime per day	16 hrs
Total uptime per year	240 days
Electricity price in Germany*	0.1233 €/kWh*
Number of units	5 pieces
Cooling capacity	2,000 W

\*0 electricity price 2012 according to BDEW

Energy costs	
Conventional cooling units	1,554.64 € annually
<b>ECOOL DTI 6401</b>	<b>1,359.61 € annually</b>
<b>Your savings</b>	<b>195.02 € annually</b>

## Assembly cost comparison



Another large potential for savings is the reduction of service and assembly time (MTTR).

## Assembly and service times (MTTR) [min]

	Conventional cooling units	<b>ECOOL</b> cooling units
Assembly	25	3
External fan change	6	6
Internal fan change	6	6
Fuse replacement	8	1
Filter change	2	1
Control board change	15	10
<b>Total</b>	<b>62</b>	<b>27</b>
Calculated hourly wage of technician	40 €	
Number of units	5	

Assembly costs	
Conventional cooling units	206.67 €
<b>ECOOL DTI 6401</b>	<b>90.00 €</b>
<b>Your savings</b>	<b>116.67 €</b>

**!** The **ECOOL** product family unites total savings potential in one unit.

## Easy Handling: Perfect service-friendliness decreases routine costs.

**Thought-out solutions for installation and service.** From the cut-out compatibility to the flexible software solutions: Pfannenberg's **ECOOL** series takes excellent accessibility and simple maintenance into consideration.



**Large fin spacing**



**Simple installation**



**Condensate evaporation system**



**Pfannenberg Sizing Software (PSS)**

- Large condenser fin spacing allow for longer maintenance periods, even without an additional Nano coating.
- One mounting cut-out for 5 different performances, 1,000–4,000 W.
- Mounting possible by 1 person in a few minutes.
- Simple accessibility to all the relevant components.
- Fast component replacement.
- Integration in established net-work possible.
- Versatile voltage supply of 380–460 V via built-in transformer.
- Integrated condensate evaporation system.



### Time-saving.

Tool-free patented mounting design allows for quick and efficient assembly that considerably reduces process costs. Don't just take our word for it! See our video demonstration on the web. Visit [www.pfannenberg.com](http://www.pfannenberg.com) to see how you can save time and money.



### Simple installation.

Pfannenberg offers cooling units with the world largest possible cut-out compatibility in order to be able to provide a unit replacement with the least possible installation work. Intelligent mounting systems minimise work during unit installation and replacement.



### Pfannenberg Sizing Software (PSS).

Pfannenberg's Sizing Software determines your cooling requirements, calculates the necessary cooling capacity and recommends the appropriate equipment components. Thus, you receive a tailor-made solution which provides you the security of a perfect dimensioning and prevents costly over dimensioning.

The PSS is online available at: [www.pfannenberg.com/pss](http://www.pfannenberg.com/pss)

## Our cooling concept provides unique flexibility.

One cut-out, all possibilities: Our active cooling units, our air/air and air/water heat exchangers have identical cut-out sizes and fit into the enclosures of all cabinet manufacturers. This makes it possible to exchange the cooling technology easily at any time, such as after an update of electrical enclosure components or another adjustment to changed temperature conditions.

Machine and plant constructors, end users and distributors enjoy this flexibility and profit from high cost savings when equipping and modifying electrical enclosures.

### 1 enclosure cut-out, 3 cooling technologies, 9 different devices – for unique flexibility and cost savings:

- Construction of one standardised enclosure cut-out.
- Selection of the appropriate cooling technology, also after completion of planning phase.
- Easy exchange of cooling technology when temperature conditions change.
- Easier to stock replacement devices for service cases.
- Less time and money needed for service and maintenance due to Plug & Play technology.

The cut-out compatibility of our solutions enables a change of cooling technology at any time.



**One enclosure cut-out for active cooling units air/air heat exchangers air/water heat exchangers**

# Do you have demanding environmental goals? We accompany you there.

Raising productivity, reducing CO<sub>2</sub> emissions and cutting costs – we are aware of the challenges companies are facing today. We offer a solution: **ECOOL** technology. Developed with the aim of maximum cost efficiency coupled with maximum performance, **ECOOL** technology represents a new standard for cost and energy savings in the thermal management of electrical enclosures. The result: it enables annual savings of over 35 % in energy costs alone.

**ECOOL** technology also sets records in ease of assembly and servicing, which brings further cost benefits. All units impress because they feature optimised MTTR\* and MTTF\*\* service factors, 1-person tool-less assembly in less than 3 minutes and a service and maintenance friendly plug & play system.

Produced out of robust sheet steel, Pfannenberg's cooling units are extremely resilient and long-lasting in testing industrial operating conditions. Depending on requirements, they are available for traditional mounting on the door or side, for partially recessed door or side mounting and the space-saving top-mounted position. Colours can easily be integrated as well because the covers can be painted or powder coated all over to suit the particular industrial design.

Whether they need filterfans, active cooling units, chillers or heaters as individual products or for combined use – leading companies around the world benefit from the advantages of Pfannenberg thermal management solutions. You, too, can contact us for a solution tailored to your needs like no other system.

\**MTTR: Mean Time To Repair.*  
\*\**MTTF: Mean Time To Failures.*

Cutting costs through energy efficiency.

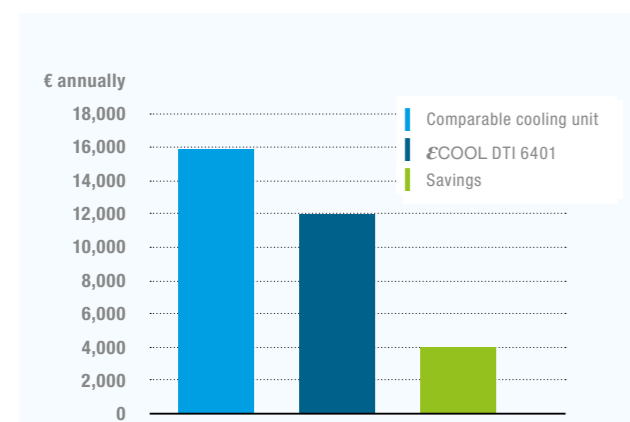

Annual savings of over 35 %

Energy costs (for 100 units):  
comparable cooling unit **approx. 16,000 € annually**  
ECOOL DTI 6401 **approx. 12,000 € annually**  
Savings **approx. 4,000 € annually**

Cutting costs through servicing ease.

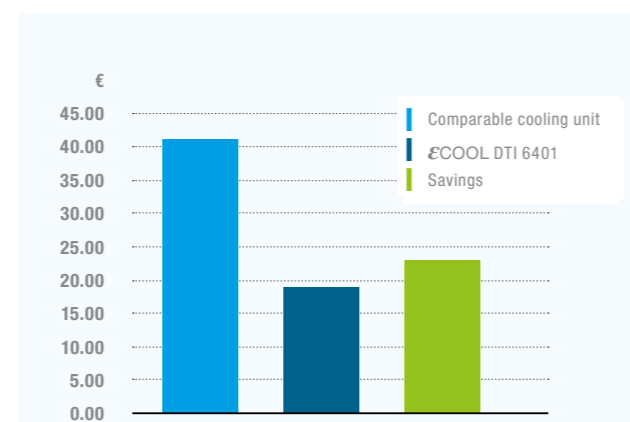

Savings of over 55 % per unit

Assembly costs (for 1 unit):  
conventional cooling unit **41.00 €**  
ECOOL DTI 6401 **18.00 €**  
Savings **23.00 €**

# Controller at a glance.



Standard Controller (SC)



Multi Controller (MC)

	SC	MC
Status LED	•	•
Main fault contact	•	•
Door contact	•	•
Integrated self test	•	•
Service interface	•	•
ECOOL-Plant V2 communication	•	•
Anti freeze control	• <sup>1)</sup>	• <sup>1)</sup>
Energy saving mode	—	•
Temperature display	—	•
Set buttons	—	•
Multi Master	—	•

<sup>1)</sup> available for top mounted cooling units (DTT) only

- Main fault contact**
- T<sub>max</sub> alert.
  - Cabinet door is open.
  - High pressure switch (e.g. high pressure in refrigerant circuit due to dirty heat exchanger or too high ambient temperature).
  - Wrong settings on the controller board.
  - Temperature sensor is broken.
- Temperature display**
- Set temperature (25–45 °C) and alarm temperature (45–60 °C) adjustable.
- Status LED**
- Ready.
  - User fault (e.g. cabinet door open).
  - System fault (e.g. high pressure switch).
  - Self test.
- Service interface at rear side of the cooling unit**
- Adjustment of set temperature and switch hysteresis.
  - Read outs and logging of temperature and error codes.
  - Converter to USB interface is available as an accessory (see page 82).
- Energy saving mode**
- Extended energy saving function and prolonged durability by switching the internal fan off.
- Multi Master**
- The possibility to combine up to 6 cooling units for simultaneous operating mode by a simple two wire connection. No complicated setting or programming of master and slave units.

## Cooling Units at a glance

- DTI** for partially recessed mounting in the door or side
- DTS** for outer mounting on the door or side
- DTT** for top mounting on the roof

TYPE	COOLING CAPACITY	RATED VOLTAGE	DIMENSIONS (HxWxD)	APPROVALS					PAGE	
				cURus	cULus	EAC	CE	Type 12		
<b>ECOOL Cooling Units</b>										
DTI 6201	1000 W	230 V   400 V 2~	1536 x 485 x 218 mm	●		●	●	●	61	
DTS 6201			1539 x 485 x 218 mm							
DTI 6301	1500 W		1536 x 485 x 218 mm	●		●	●	●		
DTS 6301			1539 x 485 x 218 mm							
DTI 6401	2000 W	400/460 V 3~	1536 x 485 x 278 mm	●		●	●	●	62	
DTS 6401			1543 x 485 x 278 mm							
DTI 6501	2500 W		1536 x 485 x 278 mm	●		●	●	●		
DTS 6501			1543 x 485 x 278 mm							
DTI 6801	4000 W		1539 x 485 x 372 mm	●		●	●	●		63
DTS 6801			1549 x 485 x 372 mm							
<b>ECOOL Cooling Units – Compact</b>										
DTI 6201C	1000 W	230 V   400 V 2~	962 x 410 x 253 mm	●		●	●	●	65	
DTS 6201C			968 x 410 x 253 mm							
DTI 6301C	1500 W		962 x 410 x 253 mm	●		●	●	●		
DTS 6301C			968 x 410 x 253 mm							
<b>ECOOL Cooling Units – Top Mounted</b>										
DTT 6101	640 W	230 V	451 x 588 x 393 mm	●		●	●	●	68	
DTT 6201	1000 W	230 V   400 V 2~		●		●	●	●		
DTT 6301	1500 W			●		●	●	●		
DTT 6401	2000 W	230 V   400/460 V 3~	435 x 595 x 495 mm	●		●	●	●	69	
DTT 6601	3000 W	400/460 V 3~	485 x 795 x 575 mm	●		●	●	●		
DTT 6801	4000 W			●		●	●	●		
<b>Cooling Units</b>										
DTS 9011H	300 W	230 V	300 x 495 x 140 mm	●		●			71	
DTI 9021	320 W		329 x 385 x 252 mm	●		●	●			
DTFI 9021	320 W		326 x 385 x 252 mm	●		●	●			
DTI 9031	510 W	230 V	562 x 310 x 212 mm	●		●	●		72	
DTS 9031			565 x 310 x 212 mm							
DTI 9041	870 W		599 x 380 x 231 mm	●		●	●			
DTS 9041			230 V   400 V 2~	604 x 380 x 231 mm						
DTI 9441	2000 W	400/460 V 3~	1536 x 485 x 240 mm	●		●	●		73	
DTS 9441			1543 x 485 x 240 mm							
DTI 9541	2500 W		1536 x 485 x 240 mm	●		●	●			
DTS 9541			1543 x 485 x 240 mm							

## Cooling Units at a glance

- DTS** for outer mounting on the door or side

TYP	COOLING CAPACITY	RATED VOLTAGE	DIMENSIONS (HxWxD)	APPROVALS					PAGE
				cURus	cULus	EAC	CE	Type 12	
<b>Outdoor Cooling Units</b>									
DTS 3031	306 W	230 V	394 x 178 x 229 mm		●	●	●		76
DTS 3061	694 W		512 x 254 x 274 mm		●	●	●		
DTS 3161	1235 W		748 x 395 x 294 mm		●	●	●		
DTS 3165	1948 W		914 x 305 x 305 mm		●	●	●		
DTS 3261	1900 W	400/460 V 3~	1209 x 395 x 326 mm		●	●	●		77
DTS 3265	3325 W		1347 x 406 x 301 mm		●	●	●		
DTS 3461	5490 W		1440 x 405 x 406 mm		●	●	●		
DTS 3661	5795 W		1665 x 485 x 520 mm		●	●	●		
<b>Outdoor Cooling Units – Stainless Steel</b>									
DTS 3031 VA	306 W	230 V	394 x 178 x 229 mm		●	●	●		78
DTS 3081	694 W		512 x 254 x 274 mm		●	●	●		
DTS 3181	1235 W	230 V   460 V 3~	748 x 395 x 294 mm		●	●	●		79
DTS 3185	1948 W	230 V	914 x 305 x 305 mm		●	●	●		
DTS 3281	1900 W	400/460 V 3~	1209 x 395 x 326 mm		●	●	●		
DTS 3285	3325 W		1347 x 406 x 301 mm		●	●	●		
DTS 3481	5490 W		1440 x 405 x 406 mm		●	●	●		
DTS 3681	5795 W		1665 x 485 x 520 mm		●	●	●		
<b>Outdoor Cooling Units – High Temperature</b>									
DTS 3061 HT	680 W	230 V	515 x 254 x 279 mm		●		●		80
DTS 3165 HT	1948 W		914 x 305 x 302 mm		●		●		
DTS 3265 HT	3040 W		1347 x 406 x 301 mm		●		●		
<b>Cooling Units – Indoor, NEMA Classification</b>									
DTS 3141	1235 W	400/460 V 3~	748 x 395 x 237 mm		●	○	●		81
DTS 3241	1900 W		1209 x 395 x 269 mm		●	○	●		
DTS 3245	3500 W		1347 x 406 x 301 mm		●	○	●		
<b>Accessories</b>									
Internal enclosure fan	230 V								39
External condensate evaporation system	230 V								82
External temperature probe									82
Condensate bottle									82
Premium TTL-USB converter									82
Air diverter internal									82
Air baffle internal									82
Filter solutions									83
Transport eye bolts									83
Quick installation frame									83
PAD air duct system									84

For additional models, options and voltages visit [www.pfannenberg.com](http://www.pfannenberg.com) or contact us directly.

● available ○ pending

# DTI/DTS 6000

## ECOOL Cooling Units

1000–4000 Watt

- DTI** Partially recessed in the side or door; elegantly integrated in the machine design; transport and escape routes are kept clear
- DTS** Door or side mounting; in the event of limited space in the cabinet; the routing of cold air to the important components in the cabinet is retained

**Tool-free mounting (DTI)**  
by 1 person is possible in less than 3 minutes with 55 % lower mounting costs.

**Integrated sealing (DTI)**, finished and perfectly mounted.

**High energy efficiency ratio (EER)** for up to 43 % energy savings and operating costs reduction.

**Condenser** with large fin spacing enables very long maintenance intervals even without additional Nano coating.

**Large distance between intake and exhaust vents** for safe air circulation and elimination of hot spots.

**Optional pre-filter** upgradable with aluminium, fleece or fluted filter, for the application of the cooling units in different ambient conditions.

**Mounting auxiliary edge** allows the cooling unit to stand freely when unpacking and before installing, and prevents the unit from slipping out uncontrollably during installation into the mounting cut-out by 1 person.



**Spring plate (DTI)** enables 1 person to install the cooling unit. This prevents it from falling out when unsupervised.

**Highest variability** due to cut-out compatibility for 5 performance classes and to Pfannenberg air/water and air/air heat exchangers.

**Additional temperature sensor** In the Multi Controller (MC) model allows the deactivation of the internal fan and condensate evaporation for additional 10 % energy savings and service life extension of the fan.

**Interface to use ECOOL-Plant software** at the Multi Controller (MC) model with operating hours counter and error history observation for preventive maintenance processes and exact error analysis.

**Service friendly** due to direct access to the PCB and the fans, thus 80 % shorter repair times.

**Integrated condensate evaporation;** no puddles of water under the device for increased operation safety.

## COOLING UNITS 1000–1500 W

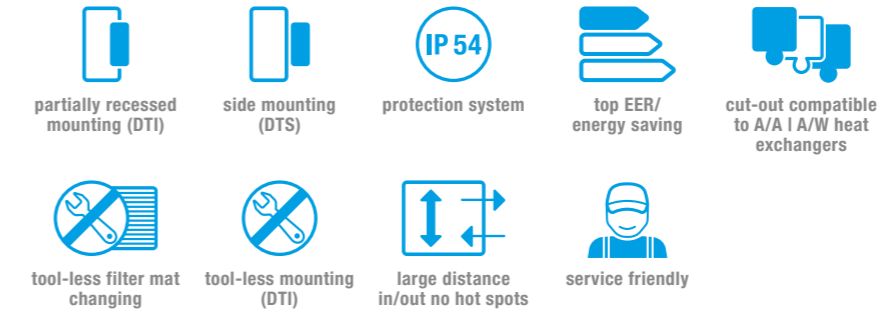

PRODUCT		DTI 6201   DTS 6201		DTI 6301   DTS 6301		Unit
ARTICLE NO.	DTI, SC	13896211055	13896219055	13896311055	13896319055	
ARTICLE NO.	DTI, MC	13896221055	13896229055	13896321055	13896329055	
ARTICLE NO.	DTS, SC	13886211055	13886219055	13886311055	13886319055	
ARTICLE NO.	DTS, MC	13886221055	13886229055	13886321055	13886329055	

DATA		AC 50   60 Hz				
Rated voltage ±10 %		230	400 2~	230	400 2~	V
Cooling capacity according to EN 14511	A35/A35	1000		1500		W
	A35/A50	780		1200		
Power consumption	A35/A35	454   567	490   570	727   868	786   863	A
Current consumption	A35/A35	3.08   3.65	2.33   2.54	5.08   5.17	3.65   3.35	
Starting current		9.1		19.7		
Pre fuse T		16	4	16	6	
Type of connection		spring-type terminal included with plug				
Unimpeded airflow (free flow)	internal	935				m <sup>3</sup> /h
Ambient temperature		+15 ... +55				°C
Control range (adjustable)	SC	+25 ... +45   factory setting +35				
	MC	+25 ... +50   factory setting +35				
Refrigerant	R134a	600				g
Condensate management		integrated condensate evaporation system with safety overflow				
Dimensions (X x Y)		485 x 1536   485 x 1539		485 x 1536   485 x 1539		mm
Installation depth (Z2) + height (Z1)		60 + 158   0 + 218		60 + 158   0 + 218		
Weight (net)		50   51	55   56	50   51	55   56	kg
Degrees of protection according to EN 60529	IP 54	towards the electrical enclosure if used as intended by the manufacturer				
	IP 34	towards the surroundings if used as intended by the manufacturer				
Design	housing	galvanised sheet steel				
	cover	electrostatically powder coated (200 °C)				
Colour	cover	RAL 7035   different colours available on request				

For additional models, options and voltages visit [www.pfannenberg.com](http://www.pfannenberg.com) or contact us directly.



Performance curves on page 165.



Comprehensive technical documentation such as

- operating instruction, technical data, approvals
- cut-out drawing, CAD | EPLAN | Zuken | WSCAD data

can be retrieved by entering this webcode in the search window on [www.pfannenberg.com](http://www.pfannenberg.com)

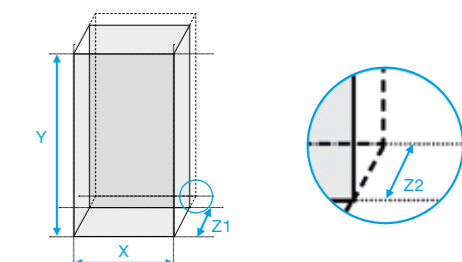

## COOLING UNITS 2000–2500 W



- partially recessed mounting (DTI)
- side mounting (DTS)
- protection system IP 54
- top EER/energy saving
- cut-out compatible to A/A | A/W heat exchangers
- tool-less filter mat changing
- tool-less mounting (DTI)
- large distance in/out no hot spots
- service friendly

PRODUCT		DTI 6401   DTS 6401		DTI 6501   DTS 6501		
ARTICLE NO.	SC	13896412055	13886412055	13896512055	13886512055	Unit
ARTICLE NO.	MC	13896422055	13886422055	13896522055	13886522055	

DATA		AC 50   60 Hz		
Rated voltage ±10 %		400/460 3~		V
Cooling capacity according to EN 14511	A35/A35	2000	2500	W
	A35/A50	1440	1800	
Power consumption	A35/A35	753   908	1048   1247	A
Current consumption	A35/A35	2.71   2.59	3.27   3.1	
Starting current		12	16	
Pre fuse T		16		
Type of connection		spring-type terminal included with plug		
Unimpeded airflow (free flow)	internal	935		m³/h
Ambient temperature		+15 ... +55		°C
Control range (adjustable)	SC	+25 ... +45   factory setting +35		
	MC	+25 ... +50   factory setting +35		
Refrigerant	R134a	1400		g
Condensate management		integrated condensate evaporation system with safety overflow		
Dimensions (X x Y)		485 x 1536   485 x 1543	485 x 1536   485 x 1543	mm
Installation depth (Z2) + height (Z1)		120 + 158   0 + 278	120 + 158   0 + 278	
Weight (net)		67   71	67   71	kg
Degrees of protection according to EN 60529	IP 54	towards the electrical enclosure if used as intended by the manufacturer		
	IP 34	towards the surroundings if used as intended by the manufacturer		
Design	housing	galvanised sheet steel		
	cover	electrostatically powder coated (200 °C)		
Colour	cover	RAL 7035   different colours available on request		

For additional models, options and voltages visit [www.pfannenberg.com](http://www.pfannenberg.com) or contact us directly.



Performance curves on page 165.



Comprehensive technical documentation such as

- operating instruction, technical data, approvals
- cut-out drawing, CAD | EPLAN | Zuken | WSCAD data

can be retrieved by entering this webcode in the search window on [www.pfannenberg.com](http://www.pfannenberg.com)

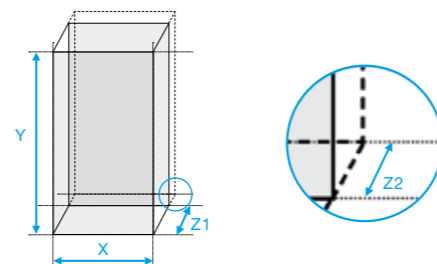

## COOLING UNITS 4000 W



- partially recessed mounting (DTI)
- side mounting (DTS)
- protection system IP 54
- top EER/energy saving
- cut-out compatible to A/A | A/W heat exchangers
- tool-less filter mat changing
- tool-less mounting (DTI)
- large distance in/out no hot spots
- service friendly

PRODUCT		DTI 6801   DTS 6801		
ARTICLE NO.	SC	13896812055	13886812055	Unit
ARTICLE NO.	MC	13896822055	13886822055	

DATA		AC 50   60 Hz		
Rated voltage ±10 %		400/460 3~		V
Cooling capacity according to EN 14511	A35/A35	4000		W
	A35/A50	3050		
Power consumption	A35/A35	1918   2369		A
Current consumption	A35/A35	4.5   4.6		
Starting current		28.3		
Pre fuse T		16		
Type of connection		spring-type terminal included with plug		
Unimpeded airflow (free flow)	internal	1450		m³/h
Ambient temperature		+15 ... +55		°C
Control range (adjustable)	SC	+25 ... +45   factory setting +35		
	MC	+25 ... +50   factory setting +35		
Refrigerant	R134a	2000		g
Condensate management		integrated condensate evaporation system with safety overflow		
Dimensions (X x Y)		485 x 1539   485 x 1549		mm
Installation depth (Z2) + height (Z1)		120 + 252   0 + 372		
Weight (net)		91   95		kg
Degrees of protection according to EN 60529	IP 54	towards the electrical enclosure if used as intended by the manufacturer		
	IP 34	towards the surroundings if used as intended by the manufacturer		
Design	housing	galvanised sheet steel		
	cover	electrostatically powder coated (200 °C)		
Colour	cover	RAL 7035   different colours available on request		

For additional models, options and voltages visit [www.pfannenberg.com](http://www.pfannenberg.com) or contact us directly.



Performance curves on page 166.



Comprehensive technical documentation such as

- operating instruction, technical data, approvals
- cut-out drawing, CAD | EPLAN | Zuken | WSCAD data

can be retrieved by entering this webcode in the search window on [www.pfannenberg.com](http://www.pfannenberg.com)

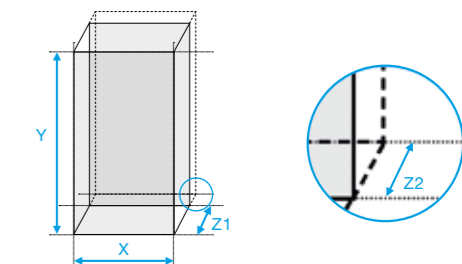

# DTI/DTS 6000C

## ECOOL Cooling Units

1000–1500 Watt

- DTI** Partially recessed in the side or door; elegantly integrated in the machine design; transport and escape routes are kept clear
- DTS** Door or side mounting; in the event of limited space in the cabinet; the routing of cold air to the important components in the cabinet is retained

- Compact design** for smaller cabinets or to cool hot spots.
- Tool-free mounting (DTI)** by 1 person is possible in less than 3 minutes with 55 % lower mounting costs.
- Very high energy efficiency ratio (EER)** for up to 43 % energy savings and operating costs reduction.
- Highest variability** due to cut-out compatibility for 2 performance classes and to Pfannenberg air/water and air/air heat exchangers.
- Service friendly** due to direct access to the PCB and the fans, thus 80 % shorter repair times.
- Integrated sealing (DTI)**, finished and perfectly mounted.
- Mounting auxiliary edge** allows the cooling unit to stand freely when unpacking and before installing, and prevents the unit from slipping out uncontrollably during installation into the mounting cut-out by 1 person.



- Spring plate (DTI)** enables 1 person to install the cooling unit. This prevents it from falling out when unsupervised.
- Additional temperature sensor** In the Multi Controller (MC) model allows the deactivation of the internal fan and condensate evaporation for additional 10 % energy savings and service life extension of the fan.
- Interface to use ECOOL-Plant software** at the Multi Controller (MC) model with operating hours counter and error history observation for preventive maintenance processes and exact error analysis.
- Optional pre-filter** upgradable with aluminium, fleece or fluted filter, for the application of the cooling units in different ambient conditions.
- Integrated condensate evaporation;** no puddles of water under the device for increased operation safety.

## COOLING UNITS 1000–1500 W



PRODUCT		DTI 6201C   DTS 6201C		DTI 6301C   DTS 6301C		Unit
ARTICLE NO.	DTI, SC	13895211055	13895219055	13895311055	13895319055	
ARTICLE NO.	DTI, MC	13895221055	13895229055	13895321055	13895329055	
ARTICLE NO.	DTS, SC	13885211055	13885219055	13885311055	13885319055	
ARTICLE NO.	DTS, MC	13885221055	13885229055	13885321055	13885329055	

DATA		AC 50   60 Hz				
Rated voltage ±10 %		230	400 2~	230	400 2~	V
Cooling capacity according to EN 14511	A35/A35	1000		1500		W
	A35/A50	590		850		
Power consumption	A35/A35	445   560	480   570	705   820	770   820	A
Current consumption	A35/A35	2.4   2.9	1.8   2.1	5   5.2	3.5   3.3	
Starting current		9.1		16		
Pre fuse T		6	4	6	4	
Type of connection		spring-type terminal included with plug				
Unimpeded airflow (free flow)	internal	885				m³/h
Ambient temperature		+15 ... +55				°C
Control range (adjustable)	SC	+25 ... +45   factory setting +35				
	MC	+25 ... +50   factory setting +35				
Refrigerant	R134a	580				g
Condensate management		integrated condensate evaporation system with safety overflow				
Dimensions (X x Y)		410 x 962   410 x 968		410 x 962   410 x 968		mm
Installation depth (Z2) + height (Z1)		62 + 181   0 + 253		62 + 181   0 + 253		
Weight (net)		40	45	40	45	kg
Degrees of protection according to EN 60529	IP 54	towards the electrical enclosure if used as intended by the manufacturer				
	IP 34	towards the surroundings if used as intended by the manufacturer				
Design	housing	galvanised sheet steel				
	cover	electrostatically powder coated (200 °C)				
Colour	cover	RAL 7035   different colours available on request				

For additional models, options and voltages visit [www.pfannenberg.com](http://www.pfannenberg.com) or contact us directly.



Performance curves on page 166.



Comprehensive technical documentation such as

- operating instruction, technical data, approvals
- cut-out drawing, CAD | EPLAN | Zuken | WSCAD data

can be retrieved by entering this webcode in the search window on [www.pfannenberg.com](http://www.pfannenberg.com)

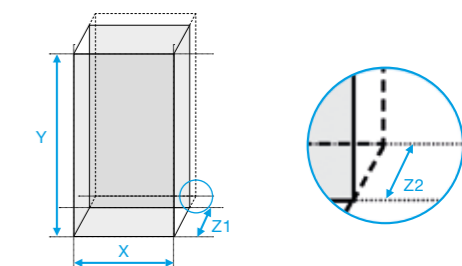

# DTT 6000

## ECOOL Cooling Units for Roof Mounting

### 500–4000 Watt

The DTT 6101–6201 cooling units use our 100 % patented condensate safety design. These cooling units are designed to be placed on top of the enclosure when there is a space shortage or aisles need to be kept clear.



**Zero sweat guarantee.**  
Condensate will not form in the cabinet where the cooling unit meets the enclosure.

**Managed water droplet control.**  
As the airflow passes through the evaporator, any condensate generated on the evaporator will not be carried into the enclosure.

**Eliminate the need for duct work.**  
Return air channels are engineered to increase the speed of the air leaving the cooling unit, ensuring cool air is effectively distributed moisture-free within the enclosure.

**One piece leak-proof moulded tub.**  
Industry's only seamless moulded condensate tray located at the top of the unit eliminates the ability for water to drip into the cabinet.

**Active condensate management**  
Condensate evaporator uses heat to eliminate condensate even when the system is not actively cooling.

**Compatible**  
with cabinets of every manufacturer.



**Energy efficient**  
Our optional Multi Controller (MC) connected to a sensor, automatically turns off the fan when it is not needed.

**Rugged steel cover**  
Powder coated or stainless steel cover designed for manufacturing environments. Easily painted to match enclosure or machine.

**Fast and easy maintenance**  
Removable cover allows for easy access to the front facing control components.

**Durable and reliable components**  
High quality compressor, fans and heat exchangers provide dependable cooling of electrical enclosure components.

**Reduced maintenance costs**  
Have a dirty environment? Use our optional tool-free quick release filter mat mounting frame and a standard Pfannenberg filter to extend the life of the unit and reduce maintenance costs.

## The DTT condensate management. Revolutionary and patented.

Main feature of the DTT's innovative condensate management is the repositioning of the cooling circuits. Moving the cold area up prevents the cold bridge to the electrical enclosure and also enables a problem-free drainage of condensate. A widespread airflow in the evaporator stops the formation of condensate buildup. And finally, the integrated air outlet nozzles make the use of conventional air hoses unnecessary; these are at risk of condensation.

### DTT – security with 4-fold condensate protection!

1. No cold bridge to the ceiling of the electrical enclosure
2. No overflow of condensate into the electrical enclosure
3. No droplets that are stirred up in the airflow
4. No air hoses that are at risk of condensation

#### 1. Cold bridge.

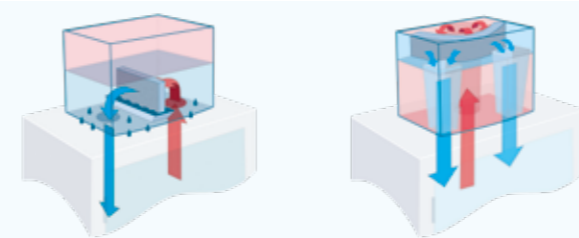

**The challenge:**  
The lower, cold area of the cooling unit has direct contact with the ceiling of the warm electrical enclosure. As a result of the cold bridge, condensate can form on the inside ceiling of the electrical enclosure and drop into the inside.

**The Pfannenberg solution:**  
Changing the position of the air-conditioning circuits. When the cold area of the cooling unit is at the top and the warm area at the bottom, a cold bridge to the electrical enclosure and the danger of condensate forming is avoided.

#### 3. Condensate buildup.

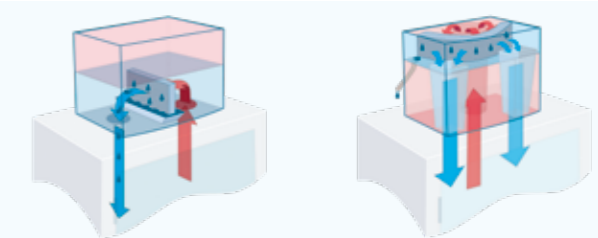

**The challenge:**  
Concentrated warm air hits the evaporator. Parts of the condensate water formed there can be carried away by the airflow and can get into the electrical enclosure with the cold air.

**The Pfannenberg solution:**  
The warm air spreads out over a large evaporator. The reduced air speed at the evaporator reduces the twirling and guarantees a condensate-free airflow in the direction of the electrical enclosure.

#### 2. Overflow of condensate.

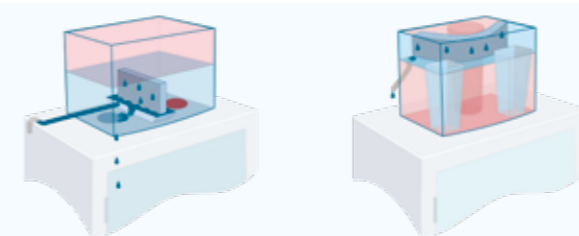

**The challenge:**  
The horizontal condensate discharge which runs along the unit's floor makes the condensate drainage more difficult. Part of the condensate water that has accumulated in the cooling unit can overflow into the electrical enclosure via the air outlet opening.

**The Pfannenberg solution:**  
Vertical drainage of the condensate. The positioning of the evaporator unit in the top part of the cooling unit makes a problem-free drainage of the condensate water without contact to the electrical enclosure possible.

#### 4. Air hoses.

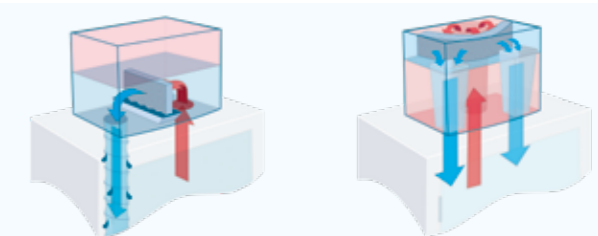

**The challenge:**  
The hoses conducting the cold air are surrounded by warm air of the electrical enclosure. As a result, condensate can form on the surface of the hose.

**The Pfannenberg solution:**  
Integrated nozzles instead of air hoses. Air outlet nozzles are positioned on both sides of the cooling unit which accelerate the cold air and conduct it condensate-free down to the bottom of the electrical enclosure.

## TOP MOUNTING COOLING UNITS 640–1500 W



PRODUCT		DTT 6101	DTT 6201	DTT 6301			
ARTICLE NO.	SC	13256141055	13256241055	13256249055	13256341055	13256349055	Unit
ARTICLE NO.	MC	13256171055	13256271055	13256279055	13256371055	13256379055	

DATA		AC 50   60 Hz									
Rated voltage ±10 %		230		400 2~		230		400 2~		V	
Cooling capacity according to EN 14511	A35/A35	640   680		1000   1080		1500   1620				W	
	A35/A50	370   400		600   640		1000   1160					
Power consumption	A35/A35	450   540		440   570		530   660		980   1140		962   1150	
Current consumption	A35/A35	2.1   2.3		2.4   2.7		1.6   1.7		5.73   7		3.75   3.6	
Starting current		19.7   23		9.1   11.5		5.2   6.2		19.7   23.2		9.8   11.6	
Pre fuse T		6		10		6		10		6	
Type of connection		spring-type terminal included with plug									
Unimpeded airflow (free flow)	internal	570/590				885/990				m³/h	
Ambient temperature		+15 ... +55									
Control range (adjustable)	SC	+25 ... +45   factory setting +35									
	MC	+25 ... +50   factory setting +35									
Refrigerant	R134a	400			725						g
Condensate management		integrated condensate evaporation system with safety overflow									
Dimensions (X x Y x Z)		588 x 451 x 393			595 x 435 x 495						mm
Weight (net)		33	35	41	45	50.5				kg	
Degrees of protection according to EN 60529	IP 54	towards the electrical enclosure if used as intended by the manufacturer									
	IP 34	towards the surroundings if used as intended by the manufacturer									
Design	housing	galvanised sheet steel									
	cover	electrostatically powder coated (200 °C)									
Colour	cover	RAL 7035   different colours available on request									

For additional models, options and voltages visit [www.pfannenberg.com](http://www.pfannenberg.com) or contact us directly.

NEMA Type 12 Performance curves on page 167.



Comprehensive technical documentation such as

- operating instruction, technical data, approvals
- cut-out drawing, CAD | EPLAN | Zuken | WSCAD data

can be retrieved by entering this webcode in the search window on [www.pfannenberg.com](http://www.pfannenberg.com)

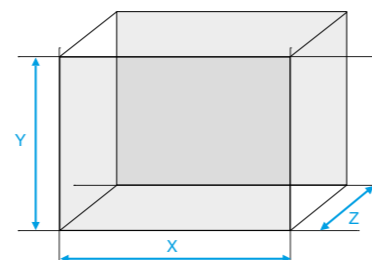

## TOP MOUNTING COOLING UNITS 2000–4000 W



PRODUCT		DTT 6401	DTT 6601	DTT 6801		
ARTICLE NO.	SC	13256441055	13256432055	13256632055	13256832055	Unit
ARTICLE NO.	MC	13256471055	13256462055	13256662055	13256862055	

DATA		AC 50   60 Hz					
Rated voltage ±10 %		230		400/460 3~		V	
Cooling capacity according to EN 14511	A35/A35	2000   2100		3000   3200		4000   4250	W
	A35/A50	1540   1600		2000   2250		3260   3495	
Power consumption	A35/A35	1049   1275		1300   1598		1700   2100	1618   2050
Current consumption	A35/A35	6.2   7		3   3,3		3.16   4.5	7.07   5
Starting current		16.80   20		10   12		8.9   9.9	17.1   19.5
Pre fuse T		6		10			
Type of connection		spring-type terminal included with plug					
Unimpeded airflow (free flow)	internal	885/990		1420/1530		m³/h	
Ambient temperature		+15 ... +55					
Control range (adjustable)	SC	+25 ... +45   factory setting +35					
	MC	+25 ... +50   factory setting +35					
Refrigerant	R134a	750		1250		g	
Condensate management		integrated condensate evaporation system with safety overflow					
Dimensions (X x Y x Z)		595 x 435 x 495		795 x 485 x 575		mm	
Weight (net)		46	51	75	77		kg
Degrees of protection according to EN 60529	IP 54	towards the electrical enclosure if used as intended by the manufacturer					
	IP 34	towards the surroundings if used as intended by the manufacturer					
Design	housing	galvanised sheet steel					
	cover	electrostatically powder coated (200 °C)					
Colour	cover	RAL 7035   different colours available on request					

For additional models, options and voltages visit [www.pfannenberg.com](http://www.pfannenberg.com) or contact us directly.

NEMA Type 12 Performance curves on page 168.

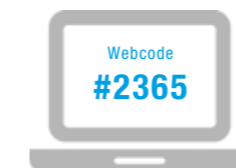

Comprehensive technical documentation such as

- operating instruction, technical data, approvals
- cut-out drawing, CAD | EPLAN | Zuken | WSCAD data

can be retrieved by entering this webcode in the search window on [www.pfannenberg.com](http://www.pfannenberg.com)

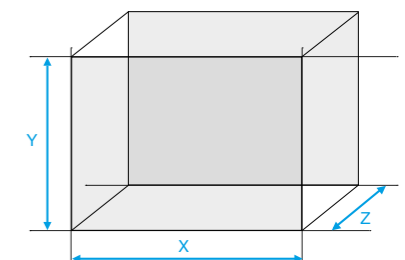

# DTI/DTS 9000

## Cooling Units

### 300–2500 Watt

- DTI** Partially recessed in the side or door; elegantly integrated in the machine design; transport and escape routes are kept clear
- DTS** Door or side mounting; in the event of limited space in the cabinet; the routing of cold air to the important components in the cabinet is retained

**Standard cooling unit** with an attractive price-performance ratio for safe cooling of industrial switch cabinets.

**Tool-free mounting (DTI)** by 1 person is possible in less than 3 minutes with 55 % lower mounting costs.

**Condenser** with large fin spacing enables very long maintenance intervals even without additional Nano coating.

**Large distance between intake and exhaust vents** for safe air circulation and elimination of hot spots.

**Mounting auxiliary edge** allows the cooling unit to stand freely when unpacking and before installing, and prevents the unit from slipping out uncontrollably during installation into the mounting cut-out by 1 person.



**Spring plate (DTI)** enables 1 person to install the cooling unit. This prevents it from falling out when unsupervised.

**Highest variability** due to cut-out compatibility for up to 4 performance classes.

**Integrated sealing (DTI),** finished and perfectly mounted.

**Integrated door and failure contact** for automatic stand-by mode, if the door is open and opening of a relay as a centralised fault indication, in the event of no voltage supply, temperature too high or too low, temperature sensor is defect or short circuit in the air circuit for example.

## COOLING UNITS 300–320 W

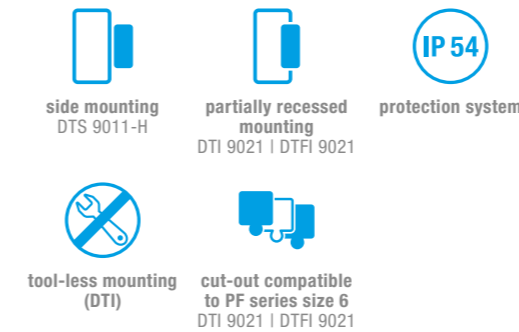

PRODUCT		DTS 9011-H	DTI 9021	DTFI 9021	
ARTICLE NO.	SC	13242541055	13293041055	13293141055	Unit

DATA				
Rated voltage ±10 %		AC 50   60 Hz		
		230		V
Cooling capacity according to EN 14511	A35/A35	300	320   340	W
	A35/A45	180	300   330	
Power consumption	A35/A35	275   290	230   240	
Current consumption	A35/A35	1.52   1.56	1.6	A
Starting current		4.52   4.66	11.7   10.9	
Pre fuse T		2	4	
Type of connection		spring-type terminal included with plug		
Unimpeded airflow (free flow)	internal	160	282	m³/h
Ambient temperature		+15 ... +45		°C
Control range (adjustable)		+25 ... +45   factory setting +35		
Refrigerant	R134a	130	350	g
Condensate management		condensate drain		
Dimensions (X x Y)		495 x 300	385 x 329	385 x 326
Installation depth (Z2) + height (Z1)		0 + 140	67 + 178	170 + 75
Weight (net)		15	17	16
Degrees of protection according to EN 60529	IP 54	towards the electrical enclosure if used as intended by the manufacturer		
	IP 34	towards the surroundings if used as intended by the manufacturer		
Design	housing	galvanised sheet steel		
	cover	electrostatically powder coated (200 °C)		
Colour	cover	RAL 7035   different colours available on request		

For additional models, options and voltages visit [www.pfannenberg.com](http://www.pfannenberg.com) or contact us directly.



Performance curves on page 166.



Comprehensive technical documentation such as  
 • operating instruction, technical data, approvals  
 • cut-out drawing, CAD | EPLAN | Zuken | WSCAD data  
 can be retrieved by entering this webcode in the search window on [www.pfannenberg.com](http://www.pfannenberg.com)

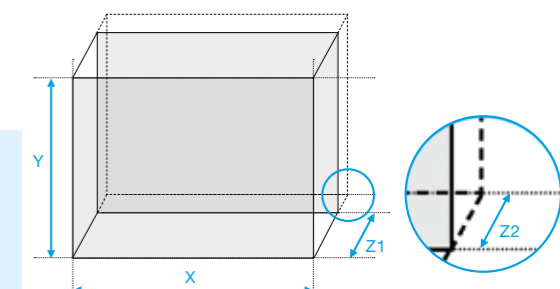

## COOLING UNITS 510–870 W

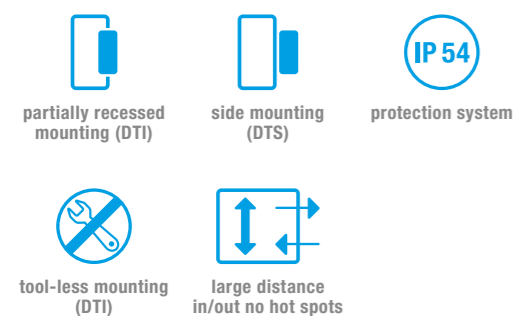

PRODUCT		DTI 9031   DTS 9031		DTI 9041   DTS 9041		DTS 9041	
ARTICLE NO.	SC	13295041055	13245041055	13299041055	13249041055	13249049055	Unit

DATA		AC 50   60 Hz			
Rated voltage ±10 %		230		400 2~	V
Cooling capacity according to EN 14511	A35/A35	510   580	870	810	W
	A35/A50	365   395	580	483	
Power consumption	A35/A35	283   337	524   634	580   702	A
Current consumption	A35/A35	1.58   1.64	3.06   3.34	3.2   3.49	
Starting current		14.31   13.8	22.16   24.15	22.2   22.02	
Pre fuse T		6	10	4	
Type of connection		spring-type terminal included with plug			
Unimpeded airflow (free flow)	internal	280	570		m³/h
Ambient temperature		+15 ... +55			°C
Control range (adjustable)		+25 ... +45   factory setting +35			
Refrigerant	R134a	250	400		g
Condensate management		condensate drain			
Dimensions (X x Y)		310 x 562   310 x 565	380 x 599   380 x 604	380 x 604	mm
Installation depth (Z2) + height (Z1)		67 + 145   0 + 212	60 + 171   0 + 231	0 + 363	
Weight (net)		21   22	29.5	37	kg
Degrees of protection according to EN 60529	IP 54	towards the electrical enclosure if used as intended by the manufacturer			
	IP 34	towards the surroundings if used as intended by the manufacturer			
Design	housing	galvanised sheet steel			
	cover	electrostatically powder coated (200 °C)			
Colour	cover	RAL 7035   different colours available on request			

For additional models, options and voltages visit [www.pfannenberg.com](http://www.pfannenberg.com) or contact us directly.



Performance curves on page 166–167.

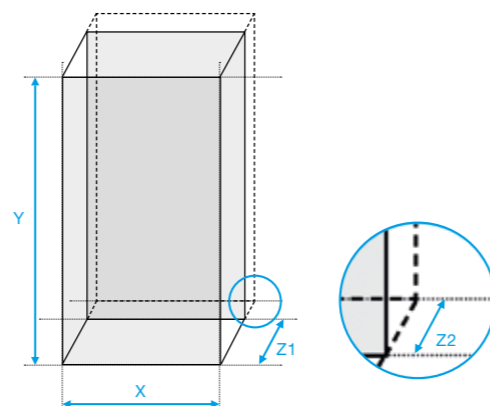

Comprehensive technical documentation such as

- operating instruction, technical data, approvals
- cut-out drawing, CAD | EPLAN | Zuken | WSCAD data

can be retrieved by entering this webcode in the search window on [www.pfannenberg.com](http://www.pfannenberg.com)

## COOLING UNITS 2000–2500 W

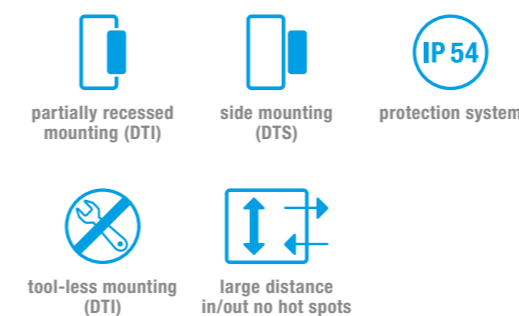

PRODUCT		DTI 9441   DTS 9441		DTI 9541   DTS 9541		
ARTICLE NO.	SC	13269432055	13289432055	13269532055	13289532055	Unit

DATA		AC 50   60 Hz			
Rated voltage ±10 %		400/460 3~			V
Cooling capacity according to EN 14511	A35/A35	2000	2500		W
	A35/A50	1440	1800		
Power consumption	A35/A35	880   1250	1140   1450		A
Current consumption	A35/A35	3.2   3.7	3.5   3.9		
Starting current		10.5   11.2	10.9   11.8		
Pre fuse T		16			
Type of connection		spring-type terminal included with plug			
Unimpeded airflow (free flow)	internal	890			m³/h
Ambient temperature		+15 ... +55			°C
Control range (adjustable)		+25 ... +45   factory setting +35			
Refrigerant	R134a	1000			g
Condensate management		condensate drain			
Dimensions (X x Y)		485 x 1536   485 x 1543	485 x 1536   485 x 1543		mm
Installation depth (Z2) + height (Z1)		120 + 120   0 + 240	120 + 120   0 + 240		
Weight (net)		67   71	67   71		kg
Degrees of protection according to EN 60529	IP 54	towards the electrical enclosure if used as intended by the manufacturer			
	IP 34	towards the surroundings if used as intended by the manufacturer			
Design	housing	galvanised sheet steel			
	cover	electrostatically powder coated (200 °C)			
Colour	cover	RAL 7035   different colours available on request			

For additional models, options and voltages visit [www.pfannenberg.com](http://www.pfannenberg.com) or contact us directly.



Performance curves on page 167.

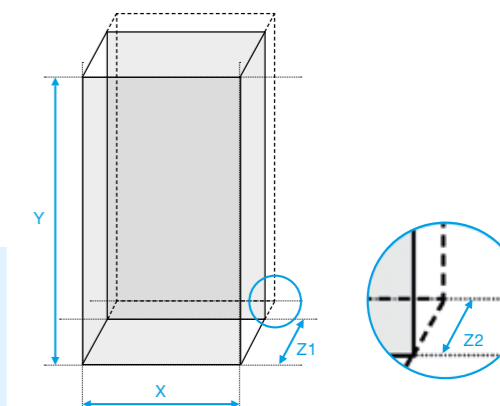

Comprehensive technical documentation such as

- operating instruction, technical data, approvals
- cut-out drawing, CAD | EPLAN | Zuken | WSCAD data

can be retrieved by entering this webcode in the search window on [www.pfannenberg.com](http://www.pfannenberg.com)

# DTS 3000

## Cooling Units

306–5795 Watt

Door or side mounting; in the event of limited space inside the cabinet; the routing of cold air to the important components in the cabinet is retained.

**Compact design**

Robust cooling unit in compact design for smaller cabinets or to cool hot spots.

**Stainless steel**

In stainless steel or powder coated with IP 56 particularly suitable for outdoor applications.

**Robust design**

using tested and energy efficient components.

**Stainless steel – wash-down**

particularly suitable for the food and beverage industry.

**Condenser**

with large fin spacing enables very long maintenance intervals even without additional Nano coating.

**Optional pre-filter**

for even greater protection for oily air.

**Coated components**

in the external circuit actively prevent corrosion caused by aggressive media (copper pipe | solder joints | heat exchanger).

**Integrated condensate evaporation;**

no puddles of water under the device for increased operation safety.



## Introducing the outdoor cooling units.

**We have a standard answer for your specific needs:**

- Outdoor applications.
- Ambient temperature up to +60 °C (HT models, see page 80).
- Harsh environment.
- Food & Beverage.
- UL listed.



**What is NEMA?**

National Electrical Manufacturers Association (NEMA) is the association of U.S. manufacturers of electrical equipment that defines the main set of construction standard for the United States and Canada.

Adherence to these standards is guaranteed by the UL certification. NEMA coding (Type 1, 3R, 12, 13, 4, 4X) can be compared with the IP coding (IP 23, 54, 56) but compared to the latter is more comprehensive and includes other factors such as protection against corrosion.

Pfannenberg cooling units from outdoor series are UL listed.

NEMA PROTECTION	1	3R	12	13	4	4X
Contact with internal contents	•	•	•	•	•	•
Falling dirt	•	•	•	•	•	•
Dripping or splashing water		•	•	•	•	•
Dust			•	•	•	•
Oils and coolants				•		
Sleet and ice		•				
Water jets					•	•
Corrosion						•
<b>IP EQUIVALENT</b>	<b>IP 23</b>	<b>IP 56</b>	<b>IP 54</b>	<b>IP 54</b>	<b>IP 56</b>	<b>IP 56</b>

## COOLING UNITS 306–1948 W

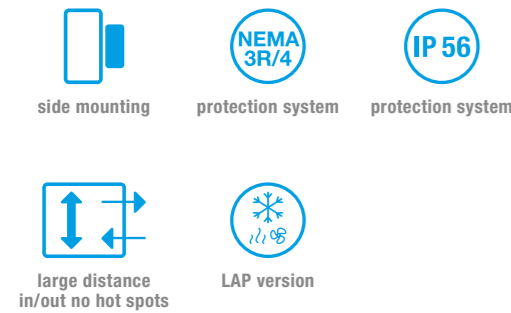

PRODUCT	DTS 3031	DTS 3061	DTS 3161	DTS 3165	
ARTICLE NO.	13383141355				Unit
ARTICLE NO. SC		13382341355	13385441355	13383639355	
ARTICLE NO. LAP <sup>1</sup>		13382341375	13385441375	13383639375	

DATA						
Rated voltage ±10 %	AC 50   60 Hz					
	230				V	
Cooling capacity according to EN 14511	A35/A35	306	694	1235	1948	W
	A35/A50	–	428	570	1045	
Power consumption	A35/A35	253	663	795	1020	A
Current consumption	A35/A35	1.2	4.1	4	6.2	
Starting current		3.5	14.4	14.9	10	
Pre fuse T		5.6	2.8	8	10	
Type of connection	spring-type terminal included with plug					
Unimpeded airflow (free flow)	internal	64	325	595	580	m <sup>3</sup> /h
Ambient temperature		+8 ... +45	+8 ... +55	0 ... +55		°C
Control range (adjustable)		+10 ... +40   factory setting +35		+25 ... +45   factory setting +35		
Refrigerant	R134a	145–150	400	400	750	g
Condensate management	integrated condensate evaporation system with safety overflow					
Dimensions (X x Y x Z)		178 x 394 x 229	254 x 512 x 274	395 x 748 x 294	305 x 918 x 305	mm
Weight (net)		14	23	40	49	kg
Degrees of protection according to NEMA	Type 3R/4					
	towards the electrical enclosure if used as intended by the manufacturer					
	Type 1 towards the surroundings if used as intended by the manufacturer					
Design	housing	galvanised sheet steel				
	cover	electrostatically powder coated (200 °C)				
Colour	cover	RAL 7035   different colours available on request				

For additional models, options and voltages visit [www.pfannenberg.com](http://www.pfannenberg.com) or contact us directly.

<sup>1</sup> LAP (Low Ambient Package): includes 900 W enclosure heater and a thermostat to be placed inside the enclosure



Performance curves on page 168–169.



Comprehensive technical documentation such as

- operating instruction, technical data, approvals
- cut-out drawing, CAD | EPLAN | Zuken | WSCAD data

can be retrieved by entering this webcode in the search window on [www.pfannenberg.com](http://www.pfannenberg.com)

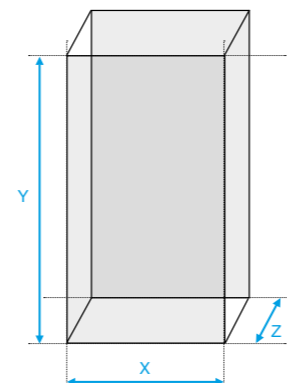

## COOLING UNITS 1900–5795 W

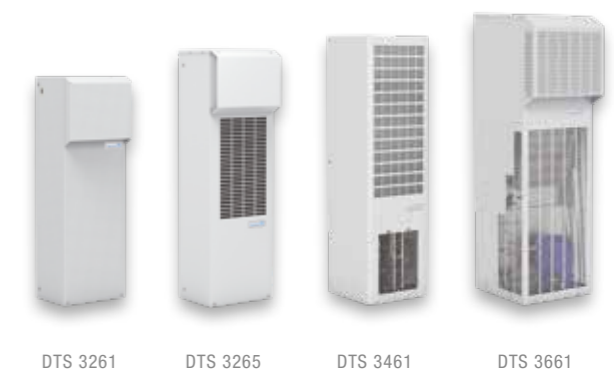
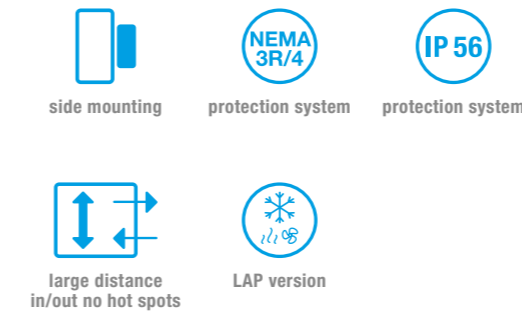

PRODUCT	DTS 3261	DTS 3265	DTS 3461	DTS 3661	
ARTICLE NO. SC	13385736355	13383836355	13385036355	13383936355	Unit
ARTICLE NO. LAP	13385736375 <sup>1</sup>	13383836375 <sup>1</sup>		13383936365 <sup>1</sup>	

DATA						
Rated voltage ±10 %	AC 50   60 Hz					
	400/460 3~				V	
Cooling capacity according to EN 14511	A35/A35	1900	3325	5490	5795	W
	A35/A50	1758	2280	4431	4678	
Power consumption	A35/A35	1400	1700	1979	2920	A
Current consumption	A35/A35	2	2.6	2.5	6.3	
Starting current		16	8	3.6	25	
Pre fuse T		5	6	7	10	
Type of connection		internal connection	spring-type terminal included with plug		internal connection	
Unimpeded airflow (free flow)	internal	765	1200	2157	2740	m <sup>3</sup> /h
Ambient temperature		0 ... +55		-4 ... +55	0 ... +55	°C
Control range (adjustable)		+25 ... +45   factory setting +35				
Refrigerant	R134a	700	1200	400	1300	g
Condensate management	integrated condensate evaporation system with safety overflow					
Dimensions (X x Y x Z)		395 x 1209 x 326	411 x 1347 x 365.2	406 x 1440 x 484.5	485 x 1665 x 520	mm
Weight (net)		67	68	79	108	kg
Degrees of protection according to NEMA	Type 3R/4					
	towards the electrical enclosure if used as intended by the manufacturer					
	Type 1 towards the surroundings if used as intended by the manufacturer					
Design	housing	galvanised sheet steel				
	cover	electrostatically powder coated (200 °C)				
Colour	cover	RAL 7035   different colours available on request				

For additional models, options and voltages visit [www.pfannenberg.com](http://www.pfannenberg.com) or contact us directly.

<sup>1</sup> LAP (Low Ambient Package): includes 900 W enclosure heater and a thermostat to be placed inside the enclosure



Performance curves on page 169.



Comprehensive technical documentation such as

- operating instruction, technical data, approvals
- cut-out drawing, CAD | EPLAN | Zuken | WSCAD data

can be retrieved by entering this webcode in the search window on [www.pfannenberg.com](http://www.pfannenberg.com)

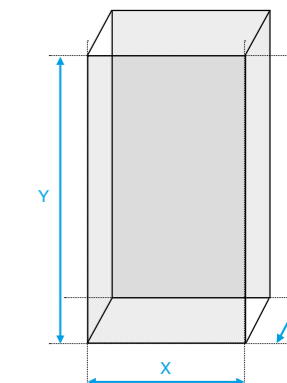

## COOLING UNITS 306–1948 W

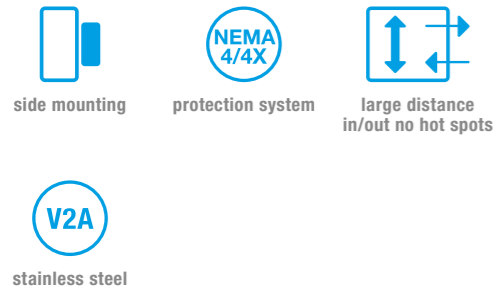

PRODUCT	DTS 3031 VA	DTS 3081	DTS 3181	DTS 3185			
ARTICLE NO.	SC	13383141158	13382341300	13385436158	13385441158	13383639158	Unit

DATA		AC 50   60 Hz					
Rated voltage ±10 %		230		460 3~	230		V
Cooling capacity according to EN 14511	A35/A35	306	694	1140   1200	1235	1948	W
	A35/A50	–	428	350	570	1045	
Power consumption	A35/A35	253	663	1200	795	1020	A
Current consumption	A35/A35	1.2	4.1	2	4	6.2	
Starting current			10.4	15	10	26	
Pre fuse T		5.6	2.8	4	8	10	
Type of connection		spring-type terminal included with plug					
Unimpeded airflow (free flow)	internal	64	150	300	190	580	m³/h
Ambient temperature		+8 ... +45	+8 ... +55	0 ... +55			°C
Control range (adjustable)		+10 ... +40   factory setting +35		+25 ... +45   factory setting +35			
Refrigerant	R134a	145–150	400		750		g
Condensate management		integrated condensate evaporation system with safety overflow					
Dimensions (X x Y x Z)		178 x 394 x 229	254 x 512 x 274	395 x 748 x 237	395 x 748 x 294	305 x 914 x 305	mm
Weight (net)		14	25	44	42	49	kg
Degrees of protection according to NEMA		Type 4/4X					
		towards the electrical enclosure if used as intended by the manufacturer					
		Type 1 towards the surroundings if used as intended by the manufacturer					
Design	housing	galvanised sheet steel					
	cover	stainless steel 304					

For additional models, options and voltages visit [www.pfannenberg.com](http://www.pfannenberg.com) or contact us directly.



Performance curves on page 168–169.



Comprehensive technical documentation such as

- operating instruction, technical data, approvals
- cut-out drawing, CAD | EPLAN | Zuken | WSCAD data

can be retrieved by entering this webcode in the search window on [www.pfannenberg.com](http://www.pfannenberg.com)

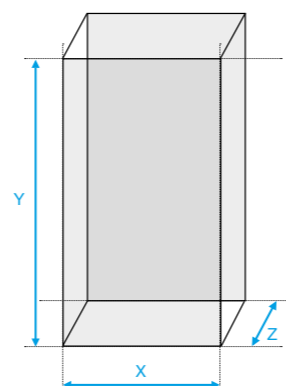

## COOLING UNITS 1900–5795 W

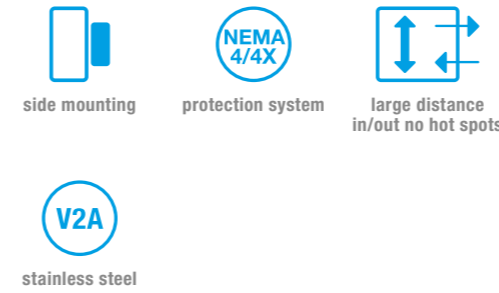

PRODUCT	DTS 3281	DTS 3285	DTS 3481	DTS 3681		
ARTICLE NO.	SC	13385736158	13383836158	13385036158	13383936158	Unit

DATA		AC 50   60 Hz				
Rated voltage ±10 %		400/460 3~				V
Cooling capacity according to EN 14511	A35/A35	1900	3325	5490	5795	W
	A35/A50	1758	2280	4431	4678	
Power consumption	A35/A35	1400	1700	1979	2920	A
Current consumption	A35/A35	2	2.6	2.5	6.3	
Starting current		16	8	3.6	25	
Pre fuse T		5	6	7	10	
Type of connection		internal connection	spring-type terminal included with plug		internal connection	
Unimpeded airflow (free flow)	internal	765	1200	2157	2740	m³/h
Ambient temperature		0 ... +55		–4 ... +55	0 ... +55	°C
Control range (adjustable)		+25 ... +45   factory setting +35				
Refrigerant	R134a	700	1200	400	1300	g
Condensate management		integrated condensate evaporation system with safety overflow				
Dimensions (X x Y x Z)		395 x 1209 x 326	411 x 1347 x 365.2	406 x 1440 x 484.5	485 x 1665 x 520	mm
Weight (net)		67	68	79	109	kg
Degrees of protection according to NEMA		Type 4/4X				
		towards the electrical enclosure if used as intended by the manufacturer				
		Type 1 towards the surroundings if used as intended by the manufacturer				
Design	housing	galvanised sheet steel				
	cover	stainless steel 304				

For additional models, options and voltages visit [www.pfannenberg.com](http://www.pfannenberg.com) or contact us directly.



Performance curves on page 169.



Comprehensive technical documentation such as

- operating instruction, technical data, approvals
- cut-out drawing, CAD | EPLAN | Zuken | WSCAD data

can be retrieved by entering this webcode in the search window on [www.pfannenberg.com](http://www.pfannenberg.com)

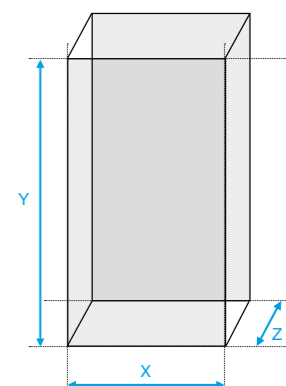

## COOLING UNITS 680–3040 W

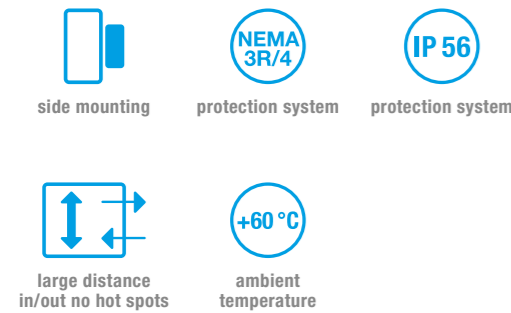

PRODUCT	DTS 3061 HT	DTS 3165 HT	DTS 3265 HT	
ARTICLE NO.	13392341005	13393641001	13393841001	Unit

DATA					
Rated voltage ±10 %		AC 50   60 Hz			
		230			V
Cooling capacity according to EN 14511	A35/A35	680	1948	3040	W
	A40/A60	265	845	1405	
Power consumption	A35/A35	360	860	1360	
Current consumption	A35/A35	1.9	7.8	7	
Starting current		6.5	26	38	A
Pre fuse T		10	10	15	
Type of connection		spring-type terminal included with plug			
Unimpeded airflow (free flow)	internal	325	1200	1200	m³/h
Ambient temperature		0 ... +60			°C
Control range (adjustable)		+25 ... +45   factory setting +35			
Refrigerant	R134a	400	900	1200	g
Condensate management		integrated condensate evaporation system with safety overflow			
Dimensions (X x Y x Z)		254 x 515 x 279	305 x 914 x 302	406 x 1347 x 301	mm
Weight (net)		23	49	68	kg
Degrees of protection according to NEMA		Type 3R/4			
		towards the electrical enclosure if used as intended by the manufacturer			
		Type 1 towards the surroundings if used as intended by the manufacturer			
Design	housing	galvanised sheet steel			
	cover	electrostatically powder coated (200 °C)			
Colour	cover	RAL 7035   different colours available on request			

For additional models, options and voltages visit [www.pfannenberg.com](http://www.pfannenberg.com) or contact us directly.



Performance curves on page 170.

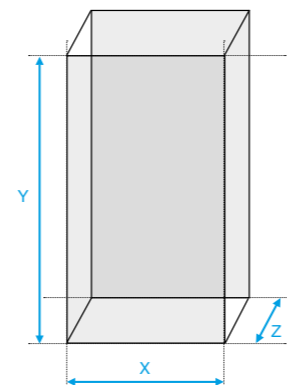

Comprehensive technical documentation such as

- operating instruction, technical data, approvals
- cut-out drawing, CAD | EPLAN | Zuken | WSCAD data

can be retrieved by entering this webcode in the search window on [www.pfannenberg.com](http://www.pfannenberg.com)

## COOLING UNITS 1235–1900 W

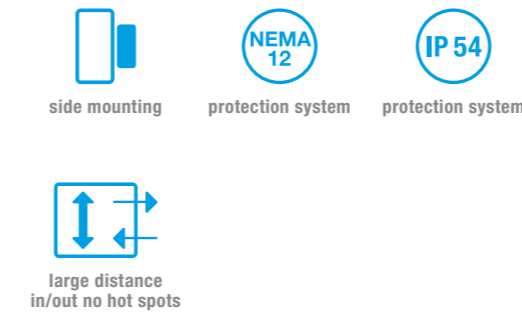

PRODUCT		DTS 3141	DTS 3241	DTS 3245	
ARTICLE NO.	SC	13385436255	13385736255	13383836255	Unit

DATA						
Rated voltage ±10 %		AC 50   60 Hz				
		400/460 3~				V
Cooling capacity according to EN 14511	A35/A35	1235	1900	3500	W	
	A35/A50	570	1758	2400		
Power consumption	A35/A35	795	1400	1700		
Current consumption	A35/A35	4	2	2.6		
Starting current		10	16	8	A	
Pre fuse T		4	5	6		
Type of connection		spring-type terminal included with plug				
Unimpeded airflow (free flow)	internal	985		1200	m³/h	
Ambient temperature		+15 ... +55				°C
Control range (adjustable)		+25 ... +45   factory setting +35				
Refrigerant	R134a	400	700	1200	g	
Condensate management		integrated condensate evaporation system with safety overflow				
Dimensions (X x Y x Z)		395 x 748 x 237	395 x 1209 x 269	406 x 1347 x 301	mm	
Weight (net)		38	54	68	kg	
Degrees of protection according to NEMA		Type 12				
		towards the electrical enclosure if used as intended by the manufacturer				
		Type 1 towards the surroundings if used as intended by the manufacturer				
Design	housing	galvanised sheet steel				
	cover	electrostatically powder coated (200 °C)				
Colour	cover	RAL 7035   different colours available on request				

For additional models, options and voltages visit [www.pfannenberg.com](http://www.pfannenberg.com) or contact us directly.



Performance curves on page 168–170.

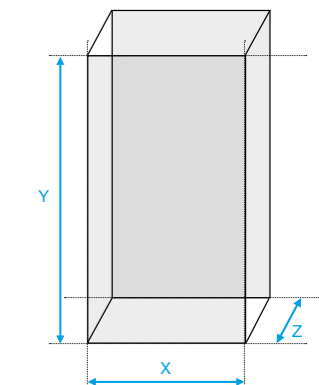

Comprehensive technical documentation such as

- operating instruction, technical data, approvals
- cut-out drawing, CAD | EPLAN | Zuken | WSCAD data

can be retrieved by entering this webcode in the search window on [www.pfannenberg.com](http://www.pfannenberg.com)

# Accessories

PRODUCT	SUITABLE FOR ...	ARTICLE NUMBER
External condensate evaporation system	all units	18314000001
External condensate evaporator (230 V 50/60 Hz) for the accumulated condensed water.		



External temperature probe	DTI/DTS 6000 with Multi Controller	18310000153
For positioning of the energy saving mode temperature probe inside the enclosure. Cable length 2.9 m.		



Condensate bottle	all units	18314000100
External container for collecting the accumulating condensed water (1 l)		



Premium TTL-USB converter	DTI/DTS 6000	18310000004
Interface-adaptor to connect Pfannenberg cooling units with the PC. For communication <b>ECOOL</b> -Plant V2.0 or higher is required. Free download on <a href="http://pfannenberg.com/en/partner-lounge/">pfannenberg.com/en/partner-lounge/</a>		



Air diverter internal	DTI/DTS 6201-6801	18300000201
For diverting the cold air downwards,		



Air baffle internal	DTI/DTS 6201-6801	18300000141
	DTI 9041   DTI 9441   DTI 9541	18300000205
For diverting the cold air optionally to the right or to the left.		



PRODUCT	SUITABLE FOR ...	ARTICLE NUMBER
<b>ECOOL</b> filter	DTI/DTS 6201-6801   DTI/DTS 6201C-6301C   DTT units produced since 2016	
Fleece filter (standard, dust)		18300000147
Fluted filter (longer service life, dust)		18300000148
Aluminium filter (oily air)		18300000149
Filter adapter <sup>1</sup> (RAL 7035, different colours available on request)		18310000151



<sup>1</sup> filter adapter only needed one time, all filters fits to the adapter

Filter kit (aluminium mesh)	DTS 3031	18881500008
	DTS 3061	18881500005
	DTS 3161   3181	18881500000
	DTS 3165   3185 <sup>2</sup>	18380000025
	DTS 3261   3281	18881500001
	DTS 3265   3285	18881500007
	DTS 3661   3681	18881500004



<sup>2</sup> for HT variants only

Transport eye bolts	all units of the 6000 series	18310000154
---------------------	------------------------------	-------------



Quick installation frame	DTT 6101   DTT 6201 produced since 2016	18310000007
	DTT 6101   DTT 6201	18300000144
	DTT 6301   DTT 6401	18300000145
	DTT 6601   DTT 6801	18300000146



For quick and easy installation or replacement.

# Accessories

PRODUCT	SUITABLE FOR ...	ARTICLE NUMBER
<b>PAD air duct system</b>		
1	PAD frame	DTT 6301   DTT 6401 1831500000
		DTT 6601   DTT 6801 1831500001
2	PAD system (air hose and 1 m tube)	DTT 6301   DTT 6401 2x 1831500002
		DTT 6601   DTT 6801 2x 1831500002
3	PAD optional tube extension (1 m)	DTT 6301   DTT 6401 1831500004
		DTT 6601   DTT 6801

Pfannenberg Air Duct System in combination with top mounted cooling units is designed to serve applications with limited space in the enclosure.

**Installation frame**

Sturdy frame for quick and easy installation of top mounted cooling units.

**Industrial standard**

The frame is made of steel with powder coating to meet industrial standards.

**Long air tube**

Allows easy delivery of cool air to the very bottom of the electrical enclosure, if the free airstream to the bottom is blocked.

**Flexible**

Air hose offers very flexible positioning of exhaust.

**Improved convection**

Cooling from bottom to top supports the natural convection of warm air.

**Optimal cooling**

The system provides an optimal air distribution in the whole enclosure.

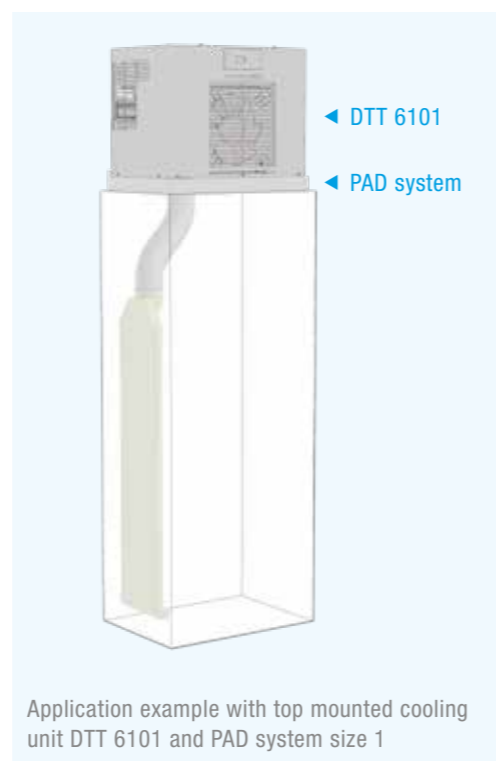

Application example with top mounted cooling unit DTT 6101 and PAD system size 1

## Pfannenberg Air Duct System for top mounted cooling units

### Application example

Even though our top mounted DTT units do not need any air ducts to cool down an electrical enclosure, there are special applications which might get challenging, such as:

Enclosures with a lot of components, several intermediate floors and also IT server usually have no sufficient space for perfect cooling air distribution. This can lead to local hot spots in the lower parts of enclosure, thus effecting negatively the life span of components.

To counter this issue Pfannenberg Air Duct system has been developed. The system consists of a metal frame, air hoses and sturdy plastic air tubes, which provide secure and efficient air distribution to any place inside the enclosure.

The system is used to provide cool air directly to the bottom of the enclosure and makes it possible to focus the air stream on specific electrical components, which have exceptionally high heat emission.

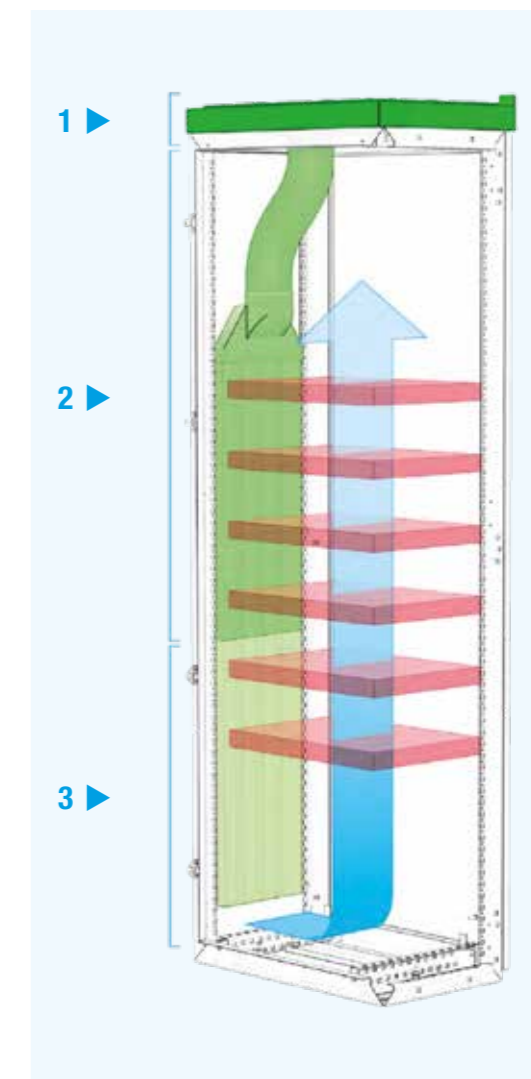

# Process reliability.

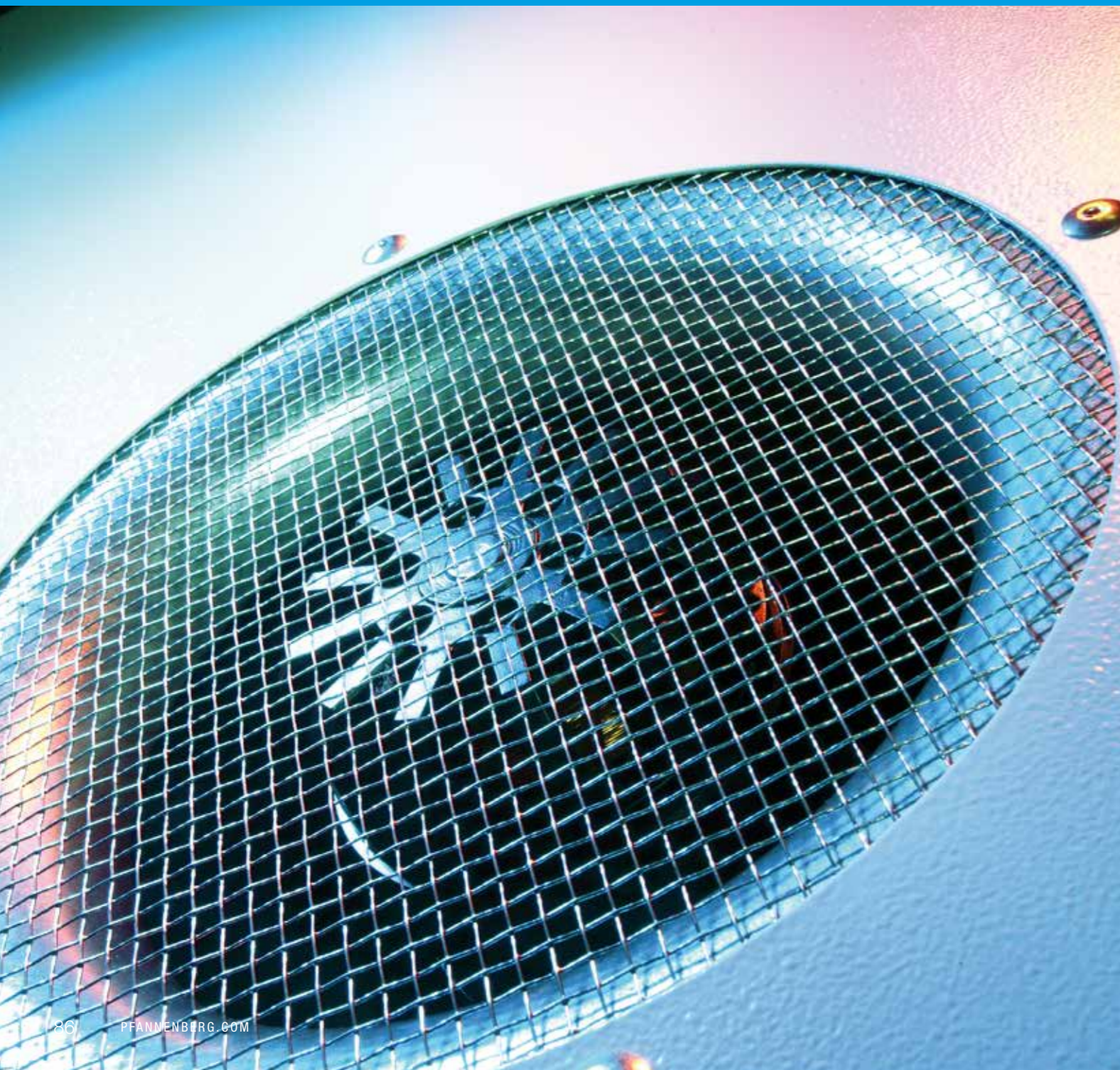

Air/Water Heat Exchangers from the PWI, PWS and PWD series.

The use of Pfannenberg air/water heat exchangers is particularly suitable where ambient temperatures are high or the atmosphere proves to be particularly oily or aggressive. Their main advantages over other air conditioner units for control cabinets are their maintenance-free operation and extremely low noise emission.

Ideal areas of use for air/water heat exchangers are wherever machines or production processes are cooled by tempered water – thus water is already available.

Protecting man, machine and the environment.

## Selecting the right air/water heat exchanger series.

Pfannenberg's air/water heat exchangers are available in 3 different series. The three design concepts make it possible to select the appropriate air/water heat exchanger for different requirements.

### Mounting options: PWI, PWS and PWD.



#### PWI

Air/water heat exchanger for partially recessed side or door mounting, extremely quick installation by one person in less than 3 minutes.



#### PWS

Air/water heat exchanger for side or door mounting. For cases when there is no available space for the air/water heat exchanger inside the control cabinet.

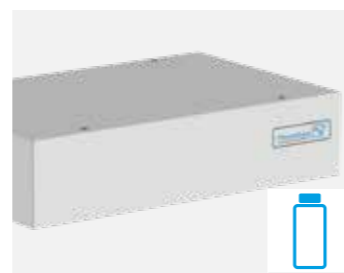

#### PWD

Air/water heat exchanger for space-saving top mounting.

### 6000 PWI/PWS series:

- Cutting edge air/water heat exchanger series for side mounting according to the latest developments in technology with strong air volume flow!
- More energy efficient than the 7000 series and partially integrated solution can be mounted in less than 3 minutes.
- Service friendly, easy to exchange fan.
- Cut-out compatible and harmonises in machine design with the 6000 cooling units and air/air heat exchangers.
- Identical airflow as the 6000 cooling units enables a problem-free cooling concept exchange.
- Modern industry design, which fits in to the machine design and includes a steel cover to endure the hard industrial day-to-day routine.

### 7000 PWS series:

- Air/water heat exchanger in proven, simple industrial version.
- This series is suitable for narrower control cabinets. Especially for mounting on the side of less deep cabinets or on narrower doors in 200 mm and 400 mm versions.
- For high performance requirements, units in 7,000 or 10,000 Watts are available.

### 5000 PWD series:

- Space-saving mounting on top of the control cabinet. Emergency escape routes and logistic paths are kept clear. Expensive storage space is saved.
- Perfect protection against mechanical damage in running production operation because it is "out of reach" of fork lift trucks and other vehicles.
- PWD air/water heat exchangers fit on cabinets of all manufacturers.

## Air/Water Heat Exchangers at a glance

**PWI** for partially recessed mounting of the heat exchanger in the door or side

**PWS** for outer mounting of the heat exchanger on the door or side

**PWD** for top-mounting of the heat exchanger on the roof

TYPE	COOLING CAPACITY	RATED VOLTAGE	DIMENSIONS (HxWxD)	APPROVALS			PAGE
				cURus	EAC	CE	

### PWI/PWS Air/Water Heat Exchangers

PWI 6102	1000 W	230 V	615 x 380 x 142 mm	•	•	•	91
PWS 6102			622.5 x 380 x 142 mm				
PWI 6152	1500 W	230 V	938 x 410 x 142 mm	•	•	•	92
PWS 6152			945.5 x 410 x 142 mm				
PWI 6302C	3000 W	400 V	938 x 410 x 142 mm	•	•	•	93
PWS 6302C			945.5 x 410 x 142 mm				
PWI 6302	3000 W	400 V	1549 x 485 x 142 mm	•	•	•	94
PWS 6302			1556 x 485 x 142 mm				
PWI 6502	5000 W	400 V	1544 x 485 x 186 mm	•	•	•	94
PWS 6502			1556 x 485 x 186 mm				
PWS 7062	600 W	230 V	500 x 200 x 100 mm	•	•	•	97
PWS 7102	950 W		500 x 200 x 150 mm	•	•	•	
PWS 7152	1500 W		950 x 400 x 115 mm	•	•	•	98
PWS 7332	3150 W		950 x 400 x 190 mm	•	•	•	
PWS 7502	5200 W	230 V	1400 x 460 x 235 mm	•	•	•	99
PWS 7702	7000 W	230 V   400 V 3~	1800 x 460 x 310 mm	•	•	•	
PWS 71002	10000 W		1800 x 600 x 315 mm	•	•	•	

### PWI T Air/Water Heat Exchangers – Water Connection on Top

PWI 6302 T	3000 W	230 V	1549 x 485 x 142 mm	•		•	95
PWI 6502 T	5000 W	230 V	1549 x 485 x 186 mm	•		•	
		400 V 2~	1544 x 485 x 186 mm	•		•	

### PWD Air/Water Heat Exchangers – Top Mounted

PWD 5302	2150 W	230 V	140 x 600 x 390 mm		•	•	101
PWD 5402	3400 W		190 x 720 x 465 mm	•	•	•	

### Accessories

Internal enclosure fan	230 V		39
External condensate evaporation system	230 V		82
Condensate bottle			82

For additional models, options and voltages visit [www.pfannenberg.com](http://www.pfannenberg.com) or contact us directly.

• available ○ pending

Further information can be found on the Internet: [www.pfannenberg.com](http://www.pfannenberg.com)

Keep up to date. Subscribe to our newsletter now: [newsletter.pfannenberg.com](http://newsletter.pfannenberg.com)

# PWI/PWS 6000

## ECOOL Air/Water Heat Exchangers

1000–5000 Watt

- PWI** Partially recessed in the side or door; elegantly integrated in the machine design; transport and escape routes are kept clear
- PWI T** Device version with water inlet and outlet from above
- PWS** Door or side mounting; in the event of limited space in the cabinet; the routing of cold air to the important components in the cabinet is retained

### Process reliability

- High airflow rate and cooling capacity.
- The heat load will not be transferred to the ambient air.
- Integrated temperature monitoring with alarm contact.

### High resilience

- Very high IP protection.
- Independent from the ambient temperature at the place of installation.

### Service and mounting-friendly

- Compact design.
- Seal requires no elaborate reworking of the mounting cut-out.
- Maintenance-free.

### Easy mounting

with tool-less clamps system for partially sunk-in version PWI.



### High efficiency

Offers the highest degree of safety and energy efficiency.

### Cut-out compatible

with ECOOL system e.g. for air/air heat exchangers and cooling units.

### Steel cover

The cover is made of sheet steel and can therefore be coloured easily.

### Economic

- System-compatible with chillers.
- Can be integrated in existing cooling circuits.
- Integrated thermostat and solenoid valve for energy-efficient temperature control.

## AIR/WATER HEAT EXCHANGERS 1000 W



PRODUCT	PWI 6102   PWS 6102		
ARTICLE NO.	12891401055	12881401055	Unit

DATA			
Rated voltage ±10 %	AC 50   60 Hz		
	230		V
Cooling capacity @ 200 l/h	W10/A35	1000	W
Power consumption	W10/A35	68   78	
Current consumption	W10/A35	0.3   0.34	A
Starting current	W10/A35	0.4	
Unimpeded airflow (free flow)	internal	520	m³/h
Cooling water connection	G 3/8" internal thread   appropriate hose nozzle in accessory pack		
Ambient temperature	+1 ... +70		
Control range (adjustable)	+8 ... +50   factory setting +35		°C
Water inlet temperature	> +2 ... +35		
Permissible operating pressure	max. 10		bar
Dimensions (X x Y)	380 x 615   380 x 622.5		mm
Installation depth (Z2) + height (Z1)	60 + 82   0 + 142		
Weight (net)	10.5   11		kg
Degrees of protection according to EN 60529	IP 55	towards the electrical enclosure if used as intended by the manufacturer	
Design	housing	galvanised sheet steel   electrostatically powder coated (200 °C)	
	heat exchanger	copper pipe with aluminium fins	
Type of connection	electro	spring-type terminal included with plug	
Colour	cover	RAL 7035   different colours available on request	

ACCESSORIES	ARTICLE NUMBER	Page
Hose extension 0.5 m	18312000002	
External condensate evaporation system	18314000001	82
Condensate bottle	18314000100	82

For additional models, options and voltages visit [www.pfannenberg.com](http://www.pfannenberg.com) or contact us directly.



Performance curves on page 170.



Comprehensive technical documentation such as

- operating instruction, technical data, approvals
- cut-out drawing, CAD | EPLAN | Zuken | WSCAD data

can be retrieved by entering this webcode in the search window on [www.pfannenberg.com](http://www.pfannenberg.com)

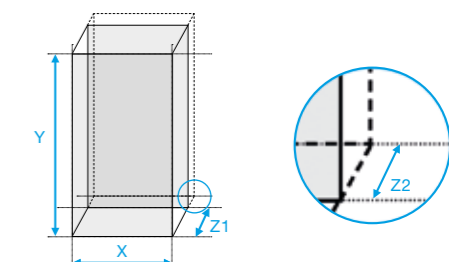

## AIR/WATER HEAT EXCHANGERS 1500 W

- partially recessed mounting (PWI)
- side mounting (PWS)
- IP 55
- top EER/energy saving
- cut out compatible to DT | A/A heat exchangers
- tool-less mounting (PWI)
- large distance in/out no hot spots
- temperature control
- temperature alarm



PRODUCT	PWI 6152   PWS 6152		
ARTICLE NO.	12892301055	12882301055	Unit

DATA			
Rated voltage ±10 %		AC 50   60 Hz	
		230	V
Cooling capacity	W10/A35	1500 @ 200 l/h	W
Power consumption	W10/A35	91   122	
Current consumption	W10/A35	0.47   0.54	A
Starting current	W10/A35	0.6	
Unimpeded airflow (free flow)	internal	850	m³/h
Cooling water connection	G 3/8" internal thread   appropriate hose nozzle in accessory pack		
Ambient temperature	+1 ... +70		
Control range (adjustable)	+8 ... +50   factory setting +35		
Water inlet temperature	> +2 ... +35		
Permissible operating pressure	max. 10		
Dimensions (X x Y)	410 x 938   410 x 945.5		
Installation depth (Z2) + height (Z1)	60 + 82   0 + 142		
Weight (net)	15   16		
Degrees of protection according to EN 60529	IP 55	towards the electrical enclosure if used as intended by the manufacturer	
Design	housing	galvanised sheet steel   electrostatically powder coated (200 °C)	
	heat exchanger	copper pipe with aluminium fins	
Type of connection	electro	spring-type terminal included with plug	
Colour	cover	RAL 7035   different colours available on request	

ACCESSORIES	ARTICLE NUMBER	Page
Hose extension 0.5 m	18312000002	
External condensate evaporation system	18314000001	82
Condensate bottle	18314000100	82

For additional models, options and voltages visit [www.pfannenberg.com](http://www.pfannenberg.com) or contact us directly.



Performance curves on page 171.



Comprehensive technical documentation such as

- operating instruction, technical data, approvals
- cut-out drawing, CAD | EPLAN | Zuken | WSCAD data

can be retrieved by entering this webcode in the search window on [www.pfannenberg.com](http://www.pfannenberg.com)

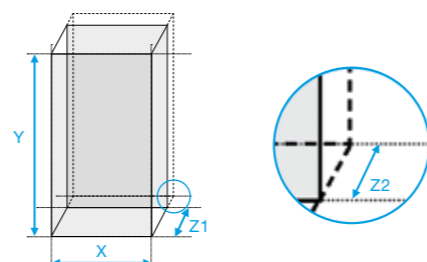

## AIR/WATER HEAT EXCHANGERS 3000 W

- partially recessed mounting (PWI)
- side mounting (PWS)
- IP 55
- top EER/energy saving
- cut out compatible to DT | A/A heat exchangers
- tool-less mounting (PWI)
- large distance in/out no hot spots
- temperature control
- temperature alarm



PRODUCT	PWI 6302C   PWS 6302C		
ARTICLE NO.	12892609055	12882609055	Unit

DATA			
Rated voltage ±10 %		AC 50   60 Hz	
		400	V
Cooling capacity	W10/A35	3000 @ 400 l/h	W
Power consumption	W10/A35	78   78	
Current consumption	W10/A35	0.36   0.35	A
Starting current	W10/A35	0.8	
Unimpeded airflow (free flow)	internal	940	m³/h
Cooling water connection	G 3/8" internal thread   appropriate hose nozzle in accessory pack		
Ambient temperature	+1 ... +70		
Control range (adjustable)	+8 ... +50   factory setting +35		
Water inlet temperature	> +2 ... +35		
Permissible operating pressure	max. 10		
Dimensions (X x Y)	410 x 938   410 x 945.5		
Installation depth (Z2) + height (Z1)	60 + 82   0 + 142		
Weight (net)	20   21		
Degrees of protection according to EN 60529	IP 55	towards the electrical enclosure if used as intended by the manufacturer	
Design	housing	galvanised sheet steel   electrostatically powder coated (200 °C)	
	heat exchanger	copper pipe with aluminium fins	
Type of connection	electro	spring-type terminal included with plug	
Colour	cover	RAL 7035   different colours available on request	

ACCESSORIES	ARTICLE NUMBER	Page
Hose extension 0.5 m	18312000002	
External condensate evaporation system	18314000001	82
Condensate bottle	18314000100	82

For additional models, options and voltages visit [www.pfannenberg.com](http://www.pfannenberg.com) or contact us directly.



Performance curves on page 171.

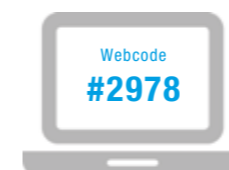

Comprehensive technical documentation such as

- operating instruction, technical data, approvals
- cut-out drawing, CAD | EPLAN | Zuken | WSCAD data

can be retrieved by entering this webcode in the search window on [www.pfannenberg.com](http://www.pfannenberg.com)

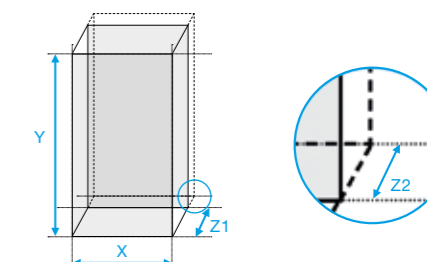

## AIR/WATER HEAT EXCHANGERS 3000–5000 W

- partially recessed mounting (PWI)
- side mounting (PWS)
- protection system
- top EER/energy saving
- cut out compatible to DT | A/A heat exchangers
- tool-less mounting (PWI)
- large distance in/out no hot spots
- temperature control
- temperature alarm



PRODUCT	PWI 6302   PWS 6302		PWI 6502   PWS 6502		
ARTICLE NO.	12893309055	12883309055	12893509055	12883509055	Unit

DATA					
Rated voltage ±10 %		AC 50   60 Hz			
		400/460 2~			V
Cooling capacity @ 400 l/h	W10/A35	3000	5000		W
Power consumption	W10/A35	53   75	79   130		A
Current consumption	W10/A35	0.47   0.49	0.69   0.83		
Starting current	W10/A35	0.6	1.6		
Unimpeded airflow (free flow)	internal	830	1410		m³/h
Cooling water connection	G 3/8" internal thread   appropriate hose nozzle in accessory pack				
Ambient temperature	+1 ... +70				
Control range (adjustable)	+8 ... +50   factory setting +35				
Water inlet temperature	> +2 ... +35				
Permissible operating pressure	max. 10				
Dimensions (X x Y)	485 x 1549   485 x 1556		485 x 1544   485 x 1556		mm
Installation depth (Z2) + height (Z1)	60 + 82   0 + 142		100 + 86   0 + 186		
Weight (net)	26   28		36.5   31.5		
Degrees of protection according to EN 60529	IP 55	towards the electrical enclosure if used as intended by the manufacturer			
Design	housing	galvanised sheet steel   electrostatically powder coated (200 °C)			
	heat exchanger	copper pipe with aluminium fins			
Type of connection	electro	spring-type terminal included with plug			
Colour	cover	RAL 7035   different colours available on request			

ACCESSORIES	ARTICLE NUMBER	Page
Hose extension 0.5 m	18312000002	
External condensate evaporation system	18314000001	82
Condensate bottle	18314000100	82

For additional models, options and voltages visit [www.pfannenberg.com](http://www.pfannenberg.com) or contact us directly.



Performance curves on page 171–172.

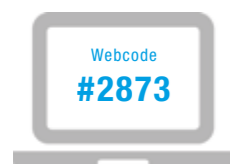

Comprehensive technical documentation such as

- operating instruction, technical data, approvals
- cut-out drawing, CAD | EPLAN | Zuken | WSCAD data

can be retrieved by entering this webcode in the search window on [www.pfannenberg.com](http://www.pfannenberg.com)

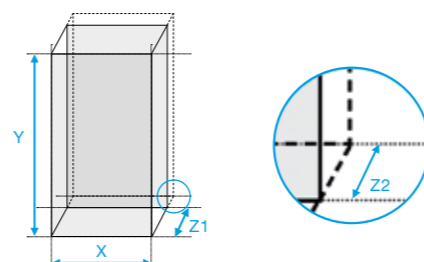

## AIR/WATER HEAT EXCHANGERS 3000–5000 W

- partially recessed mounting
- water connection on top
- protection system
- top EER/energy saving
- cut out compatible to DT | A/A heat exchangers
- tool-less mounting
- large distance in/out no hot spots
- temperature control
- temperature alarm



PRODUCT	PWI 6302 T		PWI 6502 T		
ARTICLE NO.	12893301155	12893501155	12893509155		Unit

DATA					
Rated voltage ±10 %		AC 50   60 Hz			
		230	230	400 2~	V
Cooling capacity @ 400 l/h	W10/A35	3000	5000		W
Power consumption	W10/A35	152   170	209   292	79   130	A
Current consumption	W10/A35	0.58   0.6	0.94   1.2	0.69   0.8	
Starting current	W10/A35	0.49   0.59	1.16   1.56		
Unimpeded airflow (free flow)	internal	885	1425		m³/h
Cooling water connection	hose nozzle in accordance with DIN 8542 R 1/2" (13 mm)				
Ambient temperature	+1 ... +70				
Control range (adjustable)	+8 ... +50   factory setting +35				
Water inlet temperature	10 (> +1 ... +35)				
Permissible operating pressure	max. 10				
Dimensions (X x Y)	485 x 1549	485 x 1549	485 x 1544		mm
Installation depth (Z2) + height (Z1)	60 + 82	100 + 86			
Weight (net)	24.5	31.5	36.5		
Degrees of protection according to EN 60529	IP 55	towards the electrical enclosure if used as intended by the manufacturer			
Design	housing	galvanised sheet steel   electrostatically powder coated (200 °C)			
	heat exchanger	copper pipe with aluminium fins			
Type of connection	electro	spring-type terminal included with plug			
Colour	cover	RAL 7035   different colours available on request			

ACCESSORIES	ARTICLE NUMBER	Page
Hose extension 0.5 m	18312000002	
External condensate evaporation system	18314000001	82
Condensate bottle	18314000100	82

For additional models, options and voltages visit [www.pfannenberg.com](http://www.pfannenberg.com) or contact us directly.



Performance curves on page 171–172.

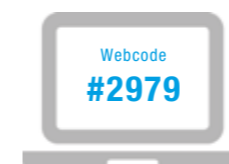

Comprehensive technical documentation such as

- operating instruction, technical data, approvals
- cut-out drawing, CAD | EPLAN | Zuken | WSCAD data

can be retrieved by entering this webcode in the search window on [www.pfannenberg.com](http://www.pfannenberg.com)

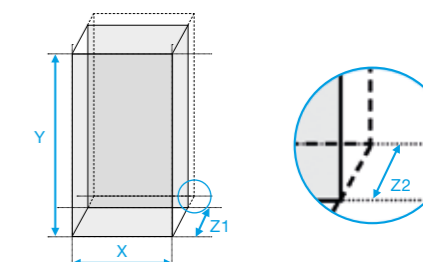

# PWS 7000

## Air/Water Heat Exchangers

600–5200 Watt

For door or side mounting; in the event of limited space, in the cabinet; the routing of cold air to the important components in the cabinet is retained.

### Process reliability

- High airflow rate and cooling capacity.
- The heat load will not be transferred to the ambient air.
- Integrated temperature monitoring with alarm contact.

### High resilience

- Very high IP protection (up to IP 65).
- Usable under aggressive environmental conditions.
- Independent from the ambient temperature at the place of installation.



### Service and mounting-friendly

- Compact design.
- Seal requires no elaborate reworking of the mounting cut-out.
- Maintenance-free.

### Robust

design, to be used under toughest ambient conditions.

### Economic

- System-compatible with chillers.
- Can be integrated in existing cooling circuits.
- Integrated thermostat and solenoid valve for energy-efficient temperature control.

## AIR/WATER HEAT EXCHANGERS 600–950 W

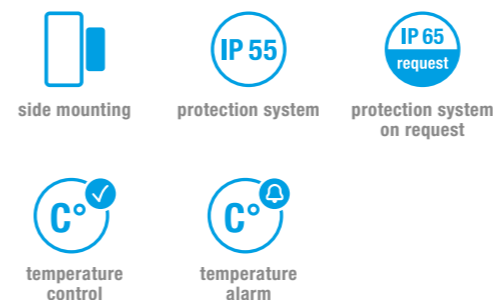

PRODUCT		PWS 7062	PWS 7102	
ARTICLE NO.	IP 55	12050610055	12051010055	Unit
ARTICLE NO.	IP 65		12051010190	

DATA				
Rated voltage ±10 %		AC 50   60 Hz		
		230		V
Cooling capacity @ 200 l/h	W10/A35	600	950	W
Power consumption	W10/A35	68   70	82   84	
Current consumption	W10/A35	0.35   0.38	0.35   0.4	A
Starting current	W10/A35	1.5   1.8	1.7   1.95	
Unimpeded airflow (free flow)	internal	440	570	m³/h
Cooling water connection	13 mm hose nozzle			
Ambient temperature	+1 ... +70			°C
Control range (adjustable)	+8 ... +50   factory setting +35			
Water inlet temperature	+1 ... +35			
Permissible operating pressure	max. 10			bar
Dimensions (X x Y x Z)		200 x 500 x 100	200 x 500 x 150	mm
Weight (net)		6	7.5	kg
Degrees of protection (EN 60529)	IP 55 towards the electrical enclosure if used as intended by the manufacturer   IP 65 on request			
Design	housing	galvanised sheet steel   electrostatically powder coated (200 °C)		
	heat exchanger	copper pipe with aluminium fins		
Type of connection	electro	spring-type terminal included with plug		
Colour	cover	RAL 7035   different colours available on request		
ACCESSORIES	ARTICLE NUMBER			Page
Hose extension 0.5 m	18312000002			
External condensate evaporation system	18314000001			82
Condensate bottle	18314000100			82

For additional models, options and voltages visit [www.pfannenberg.com](http://www.pfannenberg.com) or contact us directly.



Performance curves on page 172.

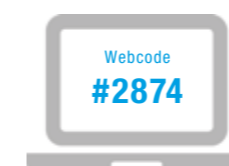

Comprehensive technical documentation such as

- operating instruction, technical data, approvals
- cut-out drawing, CAD | EPLAN | Zuken | WSCAD data

can be retrieved by entering this webcode in the search window on [www.pfannenberg.com](http://www.pfannenberg.com)

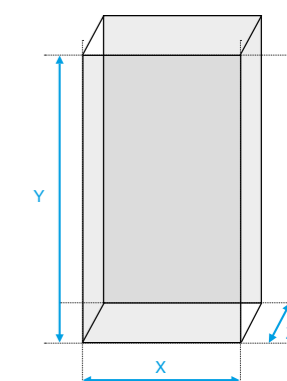

## AIR/WATER HEAT EXCHANGERS 1500–5200 W

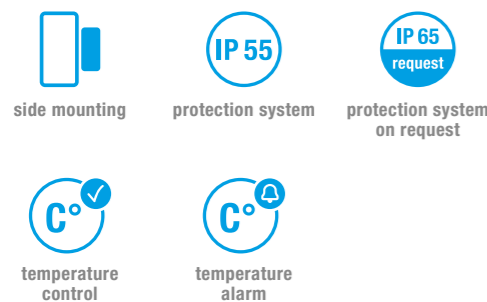

PRODUCT		PWS 7152	PWS 7332	PWS 7502	
ARTICLE NO.	IP 55	12051510055	12053010055	12055010055	Unit
ARTICLE NO.	IP 65	12051510190	12053010190		

DATA					
Rated voltage ±10 %		AC 50   60 Hz			
		230			V
Cooling capacity @ 200 l/h	W10/A35	1500	3150	5200	W
Power consumption	W10/A35	125   182	295   385	295   385	A
Current consumption	W10/A35	0.55   0.75	1.3   1.7	1.3   1.7	
Starting current	W10/A35	2   2	5.8   6.6	5.8   6.6	A
Unimpeded airflow (free flow)	internal	850	1670	1670	m³/h
Cooling water connection	13 mm hose nozzle   connections with G 3/8" internal thread on request				
Ambient temperature	+1 ... +70				
Control range (adjustable)	+8 ... +50   factory setting +35				
Water inlet temperature	+1 ... +35				
Permissible operating pressure	max. 10				
Dimensions (X x Y x Z)		400 x 950 x 115	400 x 950 x 190	460 x 1400 x 239	mm
Weight (net)		21	23	39	kg
Degrees of protection (EN 60529)	IP 55 towards the electrical enclosure if used as intended by the manufacturer   IP 65 on request				
Design	housing	galvanised sheet steel   electrostatically powder coated (200 °C)			
	heat exchanger	copper pipe with aluminium fins			
Type of connection	electro	spring-type terminal included with plug			
Colour	cover	RAL 7035   different colours available on request			
ACCESSORIES		ARTICLE NUMBER			Page
Hose extension 0.5 m		18312000002			
External condensate evaporation system		18314000001			82
Condensate bottle		18314000100			82

For additional models, options and voltages visit [www.pfannenberg.com](http://www.pfannenberg.com) or contact us directly.



Performance curves on page 173.

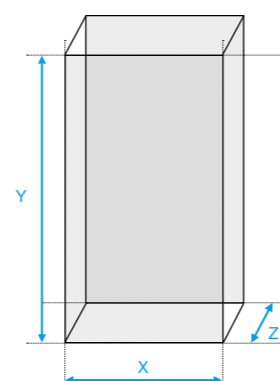

Comprehensive technical documentation such as

- operating instruction, technical data, approvals
- cut-out drawing, CAD | EPLAN | Zuken | WSCAD data

can be retrieved by entering this webcode in the search window on [www.pfannenberg.com](http://www.pfannenberg.com)

## AIR/WATER HEAT EXCHANGERS 7000–10000 W

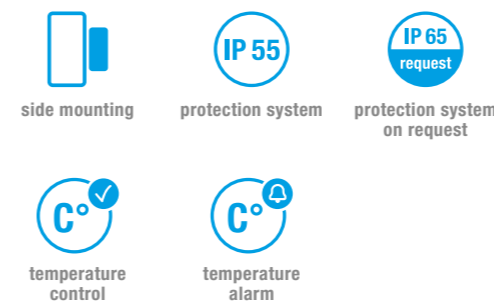

PRODUCT		PWS 7702		PWS 71002		
ARTICLE NO.		12057702055	12057710055	12057802055	12057810055	Unit

DATA						
Rated voltage ±10 %		AC 50   60 Hz				
		400 3~	230	400 3~	230	V
Cooling capacity @ 200 l/h	W10/A35	7000		10000		W
Power consumption	W10/A35	550   790	520   680	1050   1450	820   1200	A
Current consumption	W10/A35	0.8   0.95	2.4   3.2	1.9   2.2	3.8   5.2	
Starting current	W10/A35	3   3.8	9.2   12	8.3   9.4	13.5   18.8	A
Unimpeded airflow (free flow)	internal	3630	4600	5900	6250	m³/h
Cooling water connection	13 mm hose nozzle   connections with G 3/8" internal thread on request					
Ambient temperature	+1 ... +70					
Control range (adjustable)	+8 ... +50   factory setting +35					
Water inlet temperature	+1 ... +35					
Permissible operating pressure	max. 10					
Dimensions (X x Y x Z)		460 x 1800 x 310		600 x 1800 x 315		mm
Weight (net)		58		73	75	kg
Degrees of protection according to EN 60529	IP 55	towards the electrical enclosure if used as intended by the manufacturer				
Design	housing	galvanised sheet steel   electrostatically powder coated (200 °C)				
	heat exchanger	copper pipe with aluminium fins				
Type of connection	electro	spring-type terminal included with plug				
Colour	cover	RAL 7035   different colours available on request				
ACCESSORIES		ARTICLE NUMBER				Page
Hose extension 0.5 m		18312000002				
External condensate evaporation system		18314000001				82
Condensate bottle		18314000100				82

For additional models, options and voltages visit [www.pfannenberg.com](http://www.pfannenberg.com) or contact us directly.



Performance curves on page 174–175.

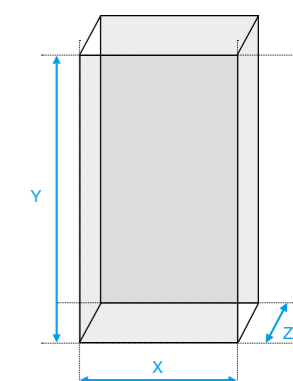

Comprehensive technical documentation such as

- operating instruction, technical data, approvals
- cut-out drawing, CAD | EPLAN | Zuken | WSCAD data

can be retrieved by entering this webcode in the search window on [www.pfannenberg.com](http://www.pfannenberg.com)

# PWD 5000

## Air/Water Heat Exchangers for Roof Mounting

### 2150–3400 Watt

The concept of top-mounting saves storage space, keeps emergency escape routes clear and protects from mechanical damage when in operation.

#### Process reliability

- High airflow rate and cooling capacity.
- The heat load will not be transferred to the ambient air.
- Integrated temperature monitoring with alarm contact.

#### Surface seal

to protect against the penetration of water via the roof surface of the control cabinet.

#### Service and mounting-friendly

- Compact design.
- Seal requires no elaborate reworking of the mounting cut-out.
- Maintenance-free.

#### Water circuit

- Pressure-tested to 30 bar.
- 10 bar maximum operating pressure.

#### Economic

- System-compatible with chillers.
- Can be integrated in existing cooling circuits.
- Integrated thermostat and solenoid valve for energy-efficient temperature control.

#### High resilience

- Very high IP protection.
- Independent from the ambient temperature at the place of installation.

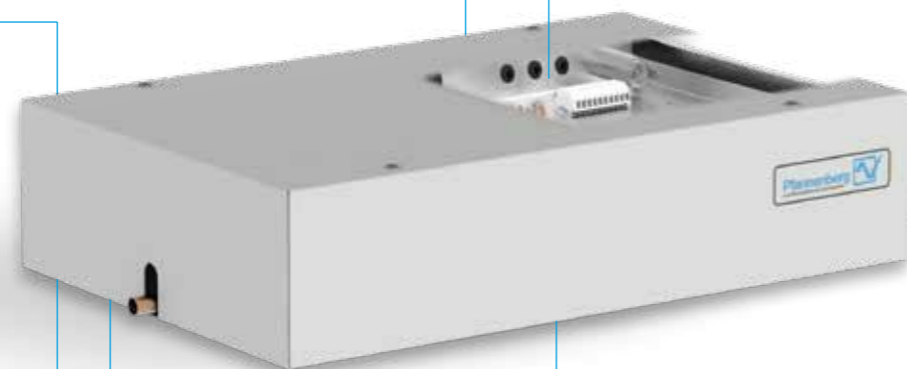

## TOP MOUNTING AIR/WATER HEAT EXCHANGERS 2150–3400 W

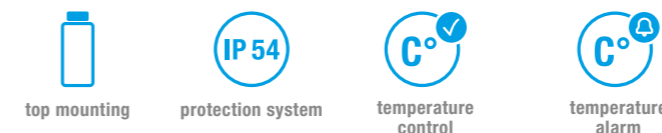

PRODUCT	PWD 5302	PWD 5402	
ARTICLE NO.	12065310055	12065410055	Unit

DATA				
Rated voltage ±10 %	AC 50   60 Hz		230	V
Cooling capacity @ 400 l/h	W10/A35	2150	3400	W
Power consumption	W10/A35	85   100	115   165	A
Current consumption	W10/A35	0.4	0.84	A
Starting current	W10/A35	3	4	A
Unimpeded airflow (free flow)	internal	500	720	m³/h
Cooling water connection	13 mm hose nozzle   connections with G 3/8" internal thread on request			
Ambient temperature	+1 ... +70			°C
Control range (adjustable)	+8 ... +50   factory setting +35			°C
Water inlet temperature	+1 ... +35			°C
Permissible operating pressure	max. 10			bar
Dimensions (X x Y x Z)	600 x 140 x 390	720 x 190 x 465		mm
Weight (net)	21	30		kg
Degrees of protection according to EN 60529	IP 54	towards the electrical enclosure if used as intended by the manufacturer		
Design	housing	galvanised sheet steel   electrostatically powder coated (200 °C)		
	heat exchanger	copper pipe with aluminium fins		
Type of connection	electro	3.5 m of cable 3 x 0.75 mm²		
Colour	cover	RAL 7035   different colours available on request		

ACCESSORIES	ARTICLE NUMBER	Page
Hose extension 0.5 m	1831200002	
External condensate evaporation system	1831400001	82
Condensate bottle	1831400010	82

For additional models, options and voltages visit [www.pfannenberg.com](http://www.pfannenberg.com) or contact us directly.



Performance curves on page 174.



Comprehensive technical documentation such as

- operating instruction, technical data, approvals
- cut-out drawing, CAD | EPLAN | Zuken | WSCAD data

can be retrieved by entering this webcode in the search window on [www.pfannenberg.com](http://www.pfannenberg.com)

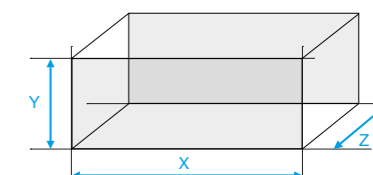

# Process efficiency.



Closing the loop for all industrial liquid cooling applications.

Rack, CCE, PC, EB and PWW series – air and liquid cooled chillers.

With manufacturing space at minimum, machine designs have become smaller and liquid cooling has emerged as the most efficient and economical means of removing process heat. Liquid cooling is especially well adapted to hot and dirty environments where it provides a method of removing the heat not only from the machines, but also from the factory itself.

Pfannenberg standard chillers reflect many years of experience in numerous areas of industry. Our customised devices are developed for a wide range of applications.

Our knowledgeable applications staff is always on hand to discuss the application and to make sure that a proper selection is made. Use our service range, too (see page 202). Especially for chillers, the professional commissioning by trained service technicians from Pfannenberg is crucial for a long term and fail-safe cooling.

Protecting man, machine and the environment.

## Whatever the application ...

Heat dissipation, temperature control and reliability of processes are mission critical for today's manufacturing machines that include the advanced automation technology required for high speed operation and high precision. Components such as spindle motors, variable frequency drives, laser and x-ray equipment all require cooling for proper operation and reliably – sometimes in harsh manufacturing environments.



## ...the perfect solution.

Pfannenberg's extensive background providing cooling for a wide variety of machines including machining centres, printing presses, wood working machines, welding systems, packaging machines and food processing machines – allows us to apply proven cooling technology to new applications as well. Our application engineering team works to match our standard products with as many applications as possible and also works closely with our product engineers to offer custom solutions when required. This continuous interaction allows continuous product development that is always in keeping with the needs of the market.



## Product expertise.

### Design.

Whether our products are cooling oil or water, Pfannenberg has well-developed global expertise in the design and manufacture of packaged refrigeration products for industrial environments. Pfannenberg process chillers optimise 3 basic areas to perform as one: the refrigeration circuit, the hydraulic circuit and controls.



### Refrigeration circuit.

Given the fact that heat can only be transferred from higher temperature to lower temperature, active chillers must make use of the Carnot cycle to lift the heat from the cooling fluid to a temperature level at that it can be transferred to ambient air or process water. Pfannenberg engineers carefully select the components of this system to maximise performance, efficiency & serviceability. Industrial compressors & fans, extended surface evaporators & condensers, along with the right refrigerant for the application, are seamlessly integrated to achieve the optimum result.

### Hydraulic circuit.

Circulating and storing the chilled water, or coolant, is the function of the hydraulic circuit. Our standard chillers include high-quality hydraulic components that are selected to for a wide range of applications. Pumps provide flexibility in terms of both flow rate and pressure capabilities.

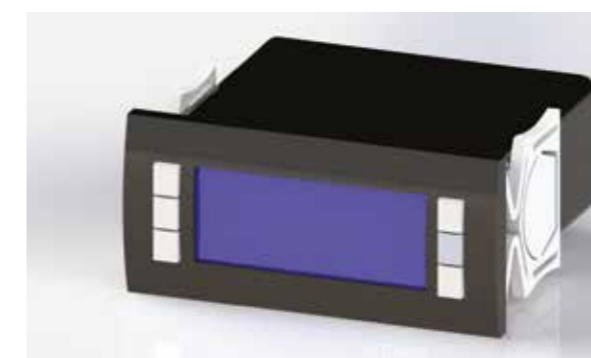

### Controls.

Proven & effective controls allow the mechanical components to work together to meet various operating requirements. Digital controllers, connected to sensors that measure temperature and switches that confirm pressure, flow and level, make the continuous logical decisions needed to provide reliable liquid cooling & circulation. Options are also available to provide remote monitoring and/or control.

## Product expertise.

### Service friendliness.

Minimum MTTR (Mean Time To Repair) and the shortest time needed to replace units thanks to perfect accessibility, standardised parts and a carefully thought-through plug-and-play concept minimise your repair costs and downtimes.



### Microchannel technology.

Microchannel heat exchanger (MCHX) for condenser coil design represents a more efficient and compact technology for air cooled chiller applications.

Benefits are:

- Reduced weight and size.
- Lower content of refrigerant.
- Increased component life.



## Pfannenbergs Protect.

Water/glycol-mixture in different concentrations and for several applications.

PRODUCT	GLYCOL CONTENT	QUANTITY	ARTICLE NO.
Pfannenbergs Protect 20P (PP20P)	20 % Propyleneglycol	20 kg	45783000123
Pfannenbergs Protect 30P (PP30P)	30 % Propyleneglycol	20 kg	45783000124
Pfannenbergs Protect 50P (PP50P)	50 % Propyleneglycol	20 kg	45783000128
		200 kg	45783000130
Pfannenbergs Protect 20E (PP20E)	20 % Ethyleneglycol	20 kg	45783000125
Pfannenbergs Protect 30E (PP30E)	30 % Ethyleneglycol	20 kg	45783000126
Pfannenbergs Protect 50E (PP50E)	50 % Ethyleneglycol	20 kg	45783000127
		200 kg	45783000129

## Performance with different cooling fluids.

MEDIUM	GLYCOL CONTENT	CORRECTION FACTOR
H <sub>2</sub> O	0 %	1.00
PP20E	20 % Ethyleneglycol	0.99
PP30E	30 % Ethyleneglycol	0.98
PP40E	40 % Ethyleneglycol	0.97
PP50E	50 % Ethyleneglycol	0.96

To calculate the cooling capacity (H<sub>2</sub>O) with different glycol concentration multiply the nominal cooling capacity by the correction factor.

## Why choose a compact chiller?

Pfannenbergs ready-to-connect chillers are versatile and ideal for applications with cooling requirements of 1.1 kW up to 150 kW. Pfannenbergs CCE Chillers are ideal for quick setup and trouble free operation.

**Coolant tank to compensate rapid changes in heat load**  
Large coolant tanks allow efficient cycling-based capacity control. Poly tanks are included for all CCE, EB and HK models. EB models can be operated as either vented or pressurised systems.

**Controls support safe and efficient operation**  
High refrigerant pressure switch and freeze protection is included as standard. Low refrigerant pressure switch, flow and/or level monitoring are some of the many control components available from the comprehensive option list suitable for almost every application. IP 54 rated enclosure to protect electrical devices.

**Designed to handle tough environments**  
Large, finned-tube condensers provide high energy efficiency and fouling resistance. Cleanable, mesh-type condenser air filters and filter monitoring are available. If process water is available, a water cooled condenser could be an option.

**High airflow and efficient operation**  
Axial type condenser fans offer high airflow to reduce condensing temperatures and increase refrigeration efficiency. The optional low ambient package includes fan cycling control. Fan speed control is available on EB and HK models to provide condensing pressure control and to save energy.

**Continuous display info and remote operation**  
A plug-in, parametric controller with digital display provides a central processing and interface point. Chiller operating information is continuously available in the display, as are warning and alarm indications. General alarm output is included as standard. Remote start/stop input as well as customised single alarms are available upon request.

**High efficiency, long life compressors**  
Industrial reciprocating type or scroll compressors provide long service life and high efficiency.

**Long service life and wider range of performance**  
High performance peripheral type pumps provide a wide range of flow and pressure capabilities to meet most application requirements. For higher pressure requirements we also offer special pumps with higher performance.

**Polyester powder coated to resist the elements**  
Galvanised steel panel construction with a polyester powder-coat finish in light grey (RAL 7035). Channel bases are included to facilitate lift truck handling and permanent foundation mounting. Optional casters are available.

**Extra surface area for lower energy usage**  
Compact and efficient, brazed plate type evaporators. The evaporators providing large heat transfer surface, low coolant pressure loss and a compact design. All evaporators are fed by externally equalised thermal expansion valves that continuously manage refrigerant flow based on load.

# Selecting the correct Pfannenberg Chiller.

Use the chart below to help you select the proper chiller for your application. For questions please consult with the factory or visit our website for the latest charts, diagrams, drawings and sizing materials and PSS software.

**STEP 1**  
WHAT IS THE HEAT LOAD?

**Determine the heat load.** There are several ways to determine the heat load depending on the application. Understanding the process is essential to calculating an accurate heat load.

**STEP 2**  
COOLANT TYPE, TEMPERATURE AND FLOW RATE

**Determine the coolant, its target temperature and the flow rate** that the chiller must provide to the process. This is determined by the method from which the heat is transferred from the process to the coolant and the type of coolant being used. For example, water has different characteristics than oil.

**STEP 3**  
IDENTIFY INSTALLATION ENVIRONMENT

**In what environment will the chiller be installed?** Indoor applications for example can see high temperatures and dirty atmospheres, while outdoor installations can experience both low and high ambient temperatures. This can effect chiller sizing and require accessories such as air filters, crank-case heaters, etc.

**STEP 4**  
USE CHILLER PERFORMANCE CURVES

**Now use the chiller performance curves** available\* to select a chiller model that meets or exceeds the required capacity based on the chilled water supply temperature and the highest expected ambient air temperature. Consideration should be given to the safety margin of the application with respect to available frame sizes to maximise the value of the chiller selection.

\*Consult factory or website for current curve data.

**STEP 5**  
CHECK PUMP PERFORMANCE CURVES

**Check the pump performance curves** available\* to ensure that the pump will provide enough pressure at the design flow rate to satisfy the application. Some liquid cooled systems have small coolant flow paths or longer distances that can have higher than average pressure losses.

\*Consult factory or website for current curve data.

**STEP 6**  
FINAL SELECTION

**Finally,** consider that the remaining application requirements such as power characteristics, control options, footprint, distributors, colour, etc. are met by the selected standard Pfannenberg chiller. Choosing a standard chiller will bring you greater reliability, easier service with common spare parts and global support.

## Chillers at a glance

TYPE	COOLING CAPACITY	RATED VOLTAGE	DIMENSIONS (HxWxD)	APPROVALS			PAGE
				cUL	EAC	CE	
<b>Rack</b>							
Rack 1100	1.1 kW	50 Hz   60 Hz 230 V	395 x 480 x 450 mm	• <sup>1</sup>	•	•	111
Rack 1700	1.7 kW			• <sup>1</sup>	•	•	
<b>PC</b>							
PC 2500	2.5 kW	50 Hz 230 V	473 x 708 x 654			•	113
<b>CCE</b>							
CCE 6101	1.1 kW	50 Hz   60 Hz 230 V	634 x 600 x 495 mm			•	117
CCE 6201	1.7 kW					•	
CCE 6301	2.4 kW					•	
CCE 6401	3.5 kW	50 Hz   60 Hz 400 V 3~   460 V 3~	983 x 600 x 676 mm			•	118
CCE 6501	5.0 kW					•	
CCE 6601	6.5 kW					•	
						•	
<b>EB 2.0 WT</b>							
EB 32 WT	3.2 kW	50 Hz 400 V 3 ~	1225 x 600 x 760 mm	⊙ <sup>2</sup>		•	121
EB 44 WT	4.4 kW			⊙ <sup>2</sup>		•	
EB 65 WT	6.5 kW	50 Hz   60 Hz 400 V 3~   460 V 3~		⊙ <sup>2</sup>		•	
EB 80 WT	8.0 kW			⊙ <sup>2</sup>		•	
EB 95 WT	9.5 kW			⊙ <sup>2</sup>		•	
EB 140 WT	14 kW		1400 x 855 x 800 mm	⊙ <sup>2</sup>		•	122
EB 160 WT	16 kW			⊙ <sup>2</sup>		•	
<b>EB 2.0 L</b>							
EB L 210 WT	21 kW	50 Hz   60 Hz 400 V 3~   460 V 3~	1410 x 1230 x 790 mm	• <sup>2</sup>	•	•	125
EB L 260 WT	26 kW			• <sup>2</sup>	•	•	
EB L 310 WT	31 kW		1410 x 1680 x 790 mm	• <sup>2</sup>	•	•	126
EB L 360 WT	36 kW			• <sup>2</sup>	•	•	
EB L 410 WT	41 kW			• <sup>2</sup>	•	•	
EB L 440 WT	44 kW			• <sup>2</sup>	•	•	127
<b>EB XT</b>							
EB XT 400 WT	37 kW	50 Hz 400 V 3 ~	2030 x 830 x 1240 mm			•	129
EB XT 500 WT	47 kW					•	
EB XT 600 WT	59 kW		2030 x 830 x 1840 mm			•	130
EB XT 700 WT	67 kW					•	
EB XT 800 WT	74 kW					•	
EB XT 900 WT	82 kW		2030 x 1200 x 2665 mm			•	131
EB XT 1000 WT	95 kW					•	
EB XT 1200 WT	116 kW				•		
EB XT 1600 WT	149 kW				•		
<b>EB 2.0 OL</b>							
EB 32 OL	3.2 kW	50 Hz 400 V 3 ~	1254 x 606 x 764 mm	⊙ <sup>2</sup>	•	•	133
EB 44 OL	4.4 kW			⊙ <sup>2</sup>	•	•	
EB 65 OL	6.5 kW	50 Hz   60 Hz 400 V 3~   460 V 3~		⊙ <sup>2</sup>	•	•	134
EB 80 OL	8.0 kW			⊙ <sup>2</sup>	•	•	
EB 95 OL	9.5 kW			⊙ <sup>2</sup>	•	•	
EB 140 OL	14 kW		1435 x 856 x 761 mm	⊙ <sup>2</sup>	•	•	135
EB 160 OL	16 kW			⊙ <sup>2</sup>	•	•	
<b>PWW (passive units)</b>							
PWW 9.000	9.0 kW	50 Hz   60 Hz 230 V	475 x 580 x 580 mm	⊙ <sup>2</sup>	•	•	137
PWW 12.000	12 kW			⊙ <sup>2</sup>	•	•	
PWW 18.000	18 kW	50 Hz   60 Hz 400 V 3~   460 V 3~		⊙ <sup>2</sup>	•	•	
PWW 24.000	24 kW			⊙ <sup>2</sup>	•	•	

For additional models, options and voltages visit [www.pfannenberg.com](http://www.pfannenberg.com) or contact us directly.

<sup>1</sup> ETL certification based on UL1995      • available   ⊙ pending   ⊕ upon request  
<sup>2</sup> ETL certification based on UL508A

# Rack Chillers

## 1.1–1.7 kW

Rugged and compact, the Rack series chillers offer a convenient and economical solution for liquid chilling applications with relatively small heat loads. Tool machines, production sites, and packaging industry are a few of the many applications to which the Rack chiller is easily applied.

**Robust standard**  
used in the field of laboratory equipment and industrial automation. Comes in 2 performance classes.

**Anodised aluminium**  
Housing cover made of anodised aluminium. Basic housing made of powder-coated sheet steel.

**Immersed evaporator**  
to ensure compact outer dimensions.

**Small size**  
Ideal for small plants with space constraints. The compact design of the unit allows it to be attached to a wide variety of machine types.

**Centrifugal pump**  
for fluid cooling with water | water/glycol mixtures.

**Microprocessor Controller**  
with digital display providing continuous operating information.

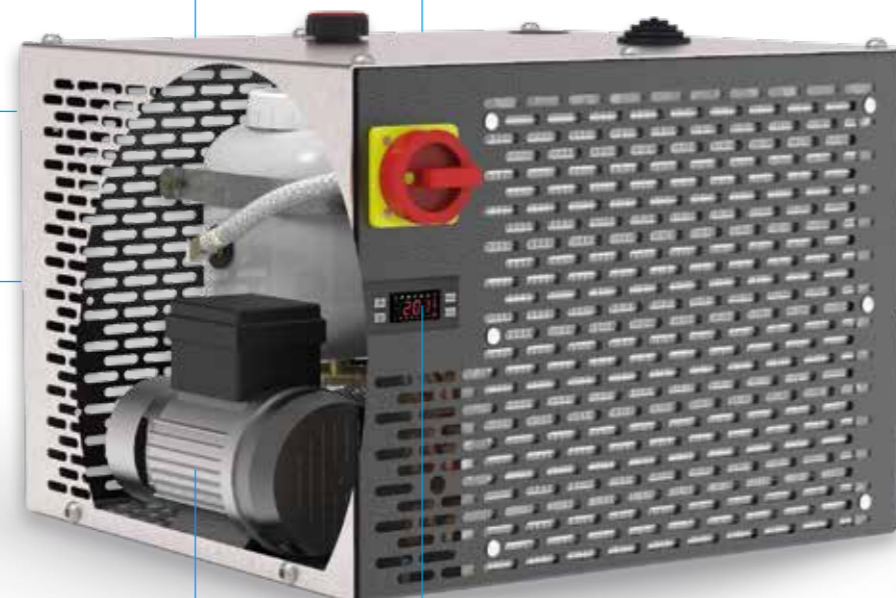

# CHILLERS 1.1–1.7 kW



PRODUCT	Rack 1100	Rack 1700	Unit	
ARTICLE NO.	42010110008	42010170011		
<b>DATA</b>				
Rated voltage	50   60		Hz ±1 %	
	230 1~		V ±10 %	
Cooling capacity (with pump)	W18/A32	1.1   1.4	1.7   2.1	kW
Flow rate (pump) <sup>1</sup>	12		l/min	
Pump pressure	2		bar	
Ambient temperature	+15 ... +45		°C	
Medium	water   water/glycol			
Medium temperature (outlet)	+13 ... +35   factory setting +18		°C	
Target value tolerance	±2		K	
Refrigerant	R134a			
Max power consumption	1.3   1.5	1.3   1.5	kW	
Max current consumption	7.4   7.6	7.4   7.6	A	
Starting current	28.2   27.7	28.2   27.7		
Control voltage	AC 230		V	
Airflow <sup>1</sup>	external	806	1182	m³/h
Tank volume	5		l	
Connections (medium)	IG	3/8"	BSP	
Dimensions (X x Y x Z)	480 x 395 x 450		mm	
Weight (net)	42		kg	
Degrees of protection of electrical equipment (EN 60529)	IP 20			
Colour	RAL 9005   cover: aluminium			

For additional models, options and voltages visit [www.pfannenberg.com](http://www.pfannenberg.com) or contact us directly.

<sup>1</sup> performance data based on 50 Hz operation

Performance curves on page 175.

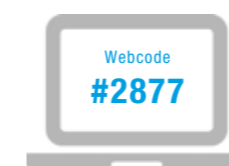

Comprehensive technical documentation such as

- operating instruction, technical data, approvals
- cut-out drawing, CAD | EPLAN | Zuken | WSCAD data

can be retrieved by entering this webcode in the search window on [www.pfannenberg.com](http://www.pfannenberg.com)

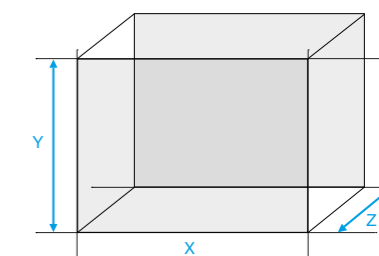

# PC 2500 Chiller 2.5 kW

Compact and ready to use air cooled water/glycol chiller. Highly recommended for applications characterised by high ambient temperature. It has been designed to ideally match your requirements in applications such as tool machines, manufacturing, industrial x-ray, induction, optical diagnostics.

### Ambient temperature up to +50 °C

Thanks to our thoughtful design, our unit operates effectively in ambient temperatures between +10 °C and +50 °C.

### Powerful low-noise pump

An energy efficient pump with reduced operating noise increases efficiency and provides better conditions for workers.

### Low content of refrigerant

With as little as 0.8 kg of R134a – far less than 5 tonnes of CO<sub>2</sub> equivalent – there is no mandatory requirement for manually leak checks or fixed leak detection systems<sup>1</sup>.



### Micro-channel condenser

Using modern microchannel heat exchangers for condenser coil design allows more efficient and compact solutions.

### Reduced maintenance costs

The optional tool-free quick release filter mat mounting frame and a standard Pfannenberg PFA exhaust filter extend the life of the unit and reduce maintenance costs.

<sup>1</sup> see EU F-gas Regulation.

## CHILLER 2.5 kW



protection system



water | water/glycol



RAL 7021



PRODUCT		PC 2500				
CONFIGURATION		Basic	H	HS	HSP	Unit
ARTICLE NO.		42160256001	42160253003	42160253004	42160253005	
<b>DATA</b>						
Rated voltage		50				Hz ±1 %
		230 1~				V ±10 %
Cooling capacity (with pump)	W15/A32	2.5				kW
Flow rate (pump)		7.5				l/min
Pump pressure		3				bar
Ambient temperature		+10 ... +50				°C
Medium		water   water/glycol				
Medium temperature (outlet)		+13 ... +30   factory setting +18				°C
Target value tolerance		±2		±1		K
Refrigerant		R134a				
Max power consumption		1.6				kW
Max current consumption		7.5				A
Starting current		26.5				
Control voltage		AC 230				V
Airflow	external	1290				m <sup>3</sup> /h
Tank volume		10				l
Connections (medium)	IG	2x G3/8"				BSP
Dimensions (X x Y x Z)		708 x 473 x 654				mm
Weight (net)		65				kg
Degrees of protection of electrical equipment (EN 60529)		IP 22				
Colour		RAL 7021				

For additional models, options and voltages visit [www.pfannenberg.com](http://www.pfannenberg.com) or contact us directly.



Performance curves on page 176.

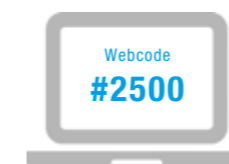

Comprehensive technical documentation such as

- operating instruction, technical data, approvals
- cut-out drawing, CAD | EPLAN | Zuken | WSCAD data

can be retrieved by entering this webcode in the search window on [www.pfannenberg.com](http://www.pfannenberg.com)

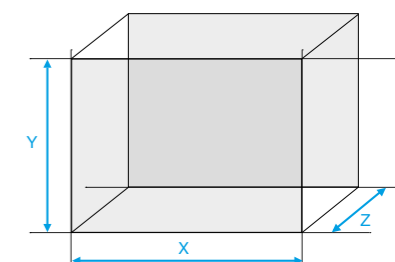

## PC 2500 – Configurations

Easily find the right product.

PRODUCT CHARACTERISTIC	CONFIGURATION					
	BASIC	H	S	HS	SP	HSP
Hydraulic Protection H (1)	–	+	/	+	/	+
Smart Cooling S (2)	–	–	/	+	/	+
Precision Cooling P (3)	–	–	/	–	/	+

1. Pump protection available in all PC 2500 chiller configurations.
2. Temperature difference control not available.
3. Fan control not available.

## PC 2500 – Product characteristics

### Product characteristic Hydraulic Protection (H)

Provides additional hydraulic features for protection of the system.

- Adjustable flow switch provides an alarm if volume flow is too low.
- Water level check protects pump from damage caused by dry running.
- Hydraulic bypass: protects pump by ensuring minimum flow and protects the application by limiting the system pressure.

*Please note: A control of the water level in the tank is standard on the PC 2500.*

### Product characteristic Smart Cooling (S)

Offers advanced temperature control and error detection.

- Temperature alarm  $T_{min}/T_{max}$  detects an unexpected increase or drop in temperature of the cooling fluid.
- Error message panel: very important for service and troubleshooting. Provides differentiated error codes (on common alarm signal).

*Please note: For single alarm messages and communication with a superior external control an additional RS 485 interface is needed.*

Some errors occur if the chiller needs service: error code and data logging helps to achieve fast and effective elimination of faults and preventive maintenance. Some errors can occur in your system even if the chiller is working properly:

- Flow alarm – volume flow of the cooling fluid of the application is out of range.
- Temperature alarm – chiller detects irregularities in the temperature profile.

### Product characteristic Precision Cooling (P)

Limits deviation from target temp to  $\pm 1$  K (must be combined with product characteristic S).

- Hot gas bypass: Improves accuracy of temperature control without stressing the compressor by frequent on/off switching (operation >50 % of nominal power required).

*Please note: For PC 2500 fan control is not available.*

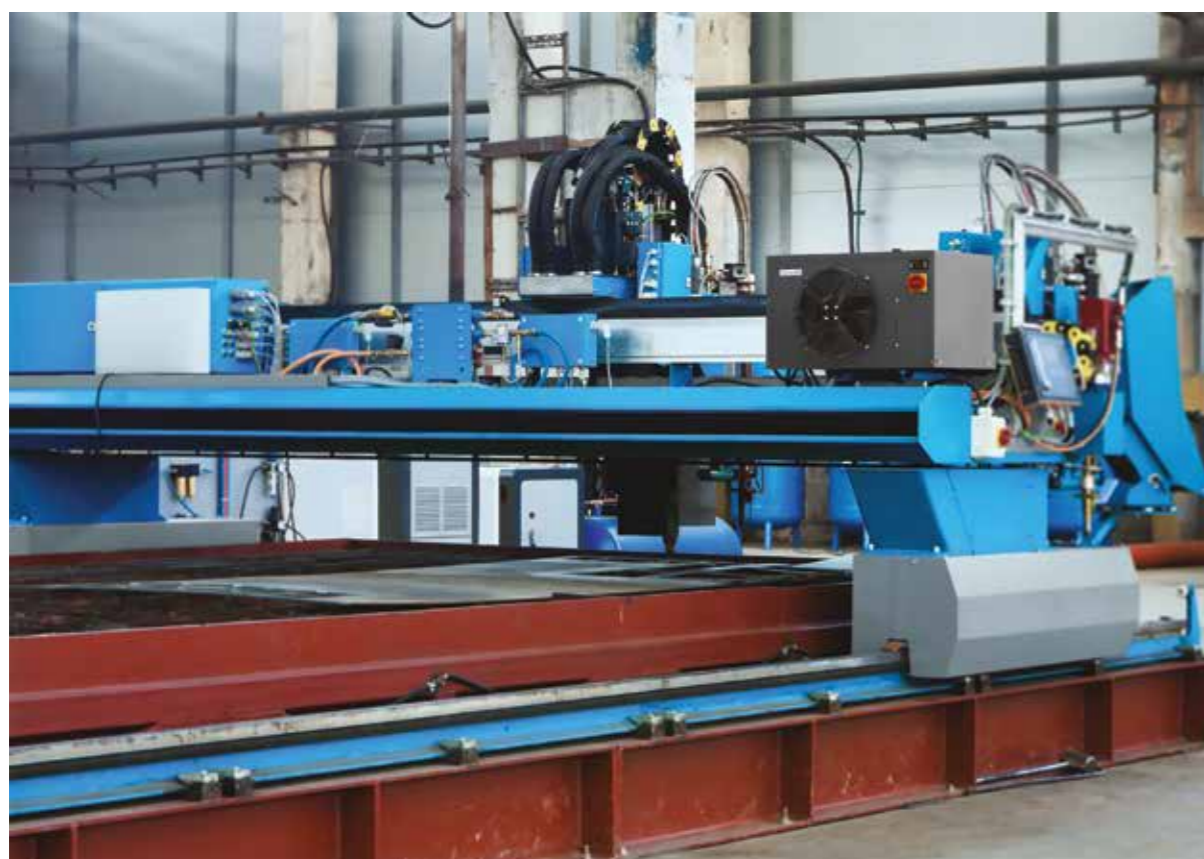

# CCE Line Chillers 1.1–6.5 kW

The compact units of series CCE 6101, CCE 6201 and CCE 6301 offer many features often found only in larger models. These chillers are a top choice for applications with increased demands regarding hydraulic system, process control and precision such as tool machines, energy systems and laboratory equipment. Due to single phase power requirements they can easily be installed in most commercial and industrial settings. The powerful units of series CCE 6401, CCE 6501, and CCE 6601 provide higher capacities up to 6.5 kW completing the portfolio of the CCE series.

**6 compact chiller models in two sizes**  
covering cooling capacities from 1.1 kW to 6.5 kW. All units are available with configurations designed for needs of industrial applications.

**Secure and simple handling**  
4 pre-assembled eyebolts provide well defined lifting points for secure handling of the unit.

**Corrosion protection as a standard**  
Hydraulic circuit made with non-ferrous components.

**Various coolant applicable**  
water and water-glycol-mixtures can be used.

**Reduced maintenance costs and extended life time**  
For use in polluted environment quick release filter mats and mounting frames are available.

**Constructed for easy maintenance**  
Removable side and front panels and a well thought-out inner structure offer a full and quick access to internal components.



**Reliable easy to read tank level**  
Improved level indication on the coolant tank.

## CHILLERS 1.1–2.4 kW



PRODUCT	CCE 6101 S	CCE 6201 S	CCE 6301 S	Unit	
ARTICLE NO.	42130115003	42130175003	42130245005		
<b>DATA</b>					
Rated voltage	50   60			Hz ±1 %	
	230 1~			V ±10 %	
Cooling capacity (with pump)	W18/A32	1.1	1.7	2.4	kW
Flow rate (pump) <sup>1</sup>	7.5			l/min	
Pump pressure	3.5			bar	
Ambient temperature	+15 ... +45			°C	
Medium	water   water/glycol				
Medium temperature (outlet)	+13 ... +35   factory setting +18			°C	
Target value tolerance	±2			K	
Refrigerant	R134a				
Max power consumption	1.2   1.4	1.3   1.5	1.5   1.7	kW	
Current consumption	7.0   7.5	6.5   7.5	7.5   8.0	A	
Starting current	40   49	40   49	45   54		
Control voltage	AC 230			V	
Airflow <sup>1</sup>	external	1300		m³/h	
Tank volume	10			l	
Connections (medium)	IG	1/2"		BSP	
Dimensions (X x Y x Z)	600 x 634 x 495			mm	
Weight (net)	67	72		kg	
Degrees of protection of electrical equipment (EN 60529)	IP 54				
Colour	RAL 7035				

For additional models, options and voltages visit [www.pfannenberg.com](http://www.pfannenberg.com) or contact us directly.

<sup>1</sup> performance data based on 50 Hz operation



Performance curves on page 176.



Comprehensive technical documentation such as

- operating instruction, technical data, approvals
- cut-out drawing, CAD | EPLAN | Zuken | WSCAD data

can be retrieved by entering this webcode in the search window on [www.pfannenberg.com](http://www.pfannenberg.com)

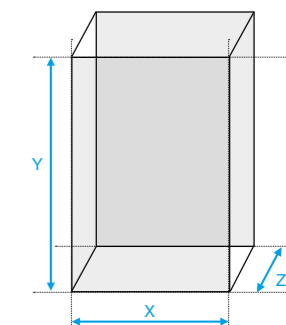

## CHILLERS 3.5–6.5 kW



PRODUCT	CCE 6401 S	CCE 6501 S	CCE 6601 S	Unit	
ARTICLE NO.	42130355004	42130505003	42130655003		
<b>DATA</b>					
Rated voltage	50   60			Hz ±1 %	
	400 3~   460 3~			V ±10 %	
Cooling capacity (with pump)	W18/A32	3.5	5	6.5	kW
Flow rate (pump) <sup>1</sup>		17			l/min
Pump pressure		2.6			bar
Ambient temperature		+15 ... +45			°C
Medium		water   water/glycol			
Medium temperature (outlet)		+13 ... +35   factory setting +18			°C
Target value tolerance		±2			K
Refrigerant		R134a			
Max power consumption	2.5   3.1	3.4   4.2	4.1   5.0		kW
Current consumption	6.5   7.0	8.0   8.5	9.5   10		A
Starting current	33   35	41   44	52   48		
Control voltage		AC 24			V
Airflow <sup>1</sup>	external	2300			m <sup>3</sup> /h
Tank volume		26			l
Connections (medium)	IG	3/4"			BSP
Dimensions (X x Y x Z)		600 x 983 x 676			mm
Weight (net)	109	111	114		kg
Degrees of protection of electrical equipment (EN 60529)		IP 54			
Colour		RAL 7035			

For additional models, options and voltages visit [www.pfannenberg.com](http://www.pfannenberg.com) or contact us directly.

<sup>1</sup> performance data based on 50 Hz operation



Performance curves on page 176–177.



Comprehensive technical documentation such as

- operating instruction, technical data, approvals
- cut-out drawing, CAD | EPLAN | Zuken | WSCAD data

can be retrieved by entering this webcode in the search window on [www.pfannenberg.com](http://www.pfannenberg.com)

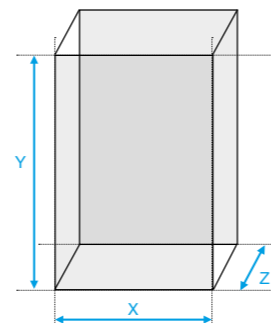

## CCE – Configurations

Easily find the right product.

PRODUCT CHARACTERISTIC	CONFIGURATION					
	BASIC	H	S	HS	SP	HSP
Hydraulic Protection H	–	+	–	+	–	+
Smart Cooling S	–	–	+	+	+	+
Precision Cooling P	–	–	–	–	+	+

### Product characteristic Hydraulic Protection (H)

Provides additional hydraulic features for protection of the system.

- Adjustable flow switch provides an alarm if volume flow is too low.
- Water level check protects pump from damage caused by dry running.
- Hydraulic bypass: protects pump by ensuring minimum flow and protects the application by limiting the system pressure.

### Product characteristic Smart Cooling (S)

Offers advanced temperature control and error detection.

- Optional differential temperature control: takes into account ambient temperature when the application has increased requirements regarding condensation and elongation.
- Temperature alarm  $T_{min}/T_{max}$  detects an unexpected increase or drop in temperature of the cooling fluid.
- Error message panel: very important for service and troubleshooting. Provides differentiated error codes (on common alarm signal).

*Please note: For single alarm messages and communication with a superior external control an additional RS 485 interface is needed.*

Some errors occur if the chiller needs service: error code and data logging helps to achieve fast and effective elimination of faults and preventive maintenance. Some errors can occur in your system even if the chiller is working properly:

- Flow alarm** – volume flow of the cooling fluid of the application is out of range.
- Temperature alarm** – chiller detects irregularities in the temperature profile.

### Product characteristic Precision Cooling (P)

Limits deviation from target temp to ±1 K (must be combined with product characteristic S).

- Hot gas bypass: Improves accuracy of temperature control without stressing the compressor by frequent on/off switching (operation >50 % of nominal power required).
- Fan on/off: improves accuracy of temperature control by influencing the performance of the condenser unit.

*Please note: Variable fan speed is only available for customised chillers with EC fans.*

# EB 2.0 WT Chillers 3.2–16 kW

The EB 2.0 series offers pre-configured units in 7 cooling capacities as well as many options to easily meet a wide range of applications such as tool machines, automotive industry, inspection technologies, packaging industry, laser applications, textile treatment, and many more. The design of these chillers takes into account requirements of high availability as well as possibility of good access for service and inspection.

### MCHX technology

Using microchannel heat exchangers for condenser coil design allows more efficient and compact solutions. The additional air filter provides greater maintenance intervals.

### Industrial design

Multi-functional basis (anti-vibration, adjustable feet, palletisable, wheels), 2 removable side panels for easy access to components, threaded inserts on top allowing 4 eye bolts lifting.

### High efficiency

Eco-design and careful selection of the main components (compressors, pumps and fans) according to ErP 2018 ensures maximum efficiency without lowering the performances.

### Ambient conditions

Suitable for environment temperatures up to +45 °C.

### Smart hydraulic circuit

Entirely non-ferrous, it may be used with deionised water. Big tank volume with water refilling, level indicator and pressure gauge on the front panel. Hydraulic connections and tank draining on the back. Horizontal centrifugal pump as a standard offering compact design, high reliability and wide performance range.



6 standard configurations plus options help finding the right chiller for many applications.

Environment friendly due to high efficiency refrigerant R410A (R407C for smaller units).

## CHILLERS 3.2–9.5 kW

protection system	water   water/glycol	microchannel technology	small hysteresis
large tank	RAL 7035	different RAL available	enhanced pump
inverter technology available	service friendly	top EER/energy saving	laser applications



PRODUCT		EB 32 WT	EB 44 WT	EB 65 WT	EB 80 WT	EB 95 WT	
ARTICLE NO.	BASIC	42030325001	42030445001	42030655001	42030805001	42030955001	Unit
<b>DATA</b>							
Rated voltage		50		50   60			Hz ±1 %
		400 3~		400 3~   460 3~			V ±10 %
Cooling capacity (with pump)	W18/A32	3.2	4.4	6.5   7.2	8.0   8.8	9.5   10.6	kW
Flow rate (pump) <sup>1</sup>		8.6	12.3	17.2	21.5	25.8	l/min
Pump pressure		2.5		3.0			bar
Ambient temperature		+15 ... +45					°C
Medium		water   water/glycol					
Medium temperature (outlet)		+13 ... +35   factory setting +18					°C
Target value tolerance		±2					K
Refrigerant		R407C		R410A			
Max power consumption		2.1	2.8	2.8   3.95	3.3   4.6	3.8   5.2	kW
Max current consumption		4.7	6.7	6.8   7.6	7.6   8.4	8.5   9.8	A
Starting current		19   21	21   23	24   27	28   31	33   36	
Control voltage		AC 24					V
Airflow <sup>1</sup>	external	2500   2750		4000   4400		5000   5500	m³/h
Tank volume		50					l
Connections (medium)	IG	1/2"		3/4"			BSP
Dimensions (X x Y x Z)		600 x 1225 x 760					mm
Weight (net)		120	125	140	150	160	kg
Degrees of protection of electrical equipment (EN 60529)		IP 54					
Colour		RAL 7035   different colours available on request					

For additional models, options and voltages visit [www.pfannenberg.com](http://www.pfannenberg.com) or contact us directly.

<sup>1</sup> performance data based on 50 Hz operation

Performance curves on page 177.

The performance curves do include standard pump losses and refer to 50 Hz and 20 % glycol mixtures. For a 40 °C ambient temperature you can expect capacity values shown for 32 °C to decrease by 20 %. For a 45 °C ambient temperature you can expect capacity values shown for 32 °C to decrease by 30 %.

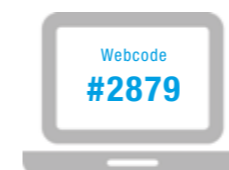

Comprehensive technical documentation such as

- operating instruction, technical data, approvals
- cut-out drawing, CAD | EPLAN | Zuken | WSCAD data

can be retrieved by entering this webcode in the search window on [www.pfannenberg.com](http://www.pfannenberg.com)

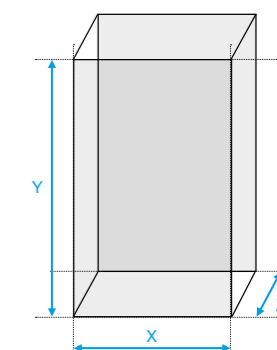

## CHILLERS 14–16 kW



PRODUCT	EB 140 WT		EB 160 WT		Unit
ARTICLE NO.	42031405001		42031605001		Unit
<b>DATA</b>					
Rated voltage	50   60				Hz ±1 %
	400 3~   460 3~				V ±10 %
Cooling capacity (with pump)	W18/A32	14   15.4	16   17.6		kW
Flow rate (pump) <sup>1</sup>		37.3	43		l/min
Pump pressure		3.0			bar
Ambient temperature		+15 ... +45			°C
Medium		water   water/glycol			
Medium temperature (outlet)		+13 ... +35   factory setting +18			°C
Target value tolerance		±2			K
Refrigerant		R410A			
Max power consumption		5.3   11.3	7.1   14.1		kW
Max current consumption		6.8   11.9	18.9   15.1		A
Starting current		46   47	46   47		
Control voltage		AC 24			V
Airflow <sup>1</sup>	external	7500   8250			m <sup>3</sup> /h
Tank volume		70			l
Connections (medium)	IG	1"			BSP
Dimensions (X x Y x Z)		855 x 1435 x 761			mm
Weight (net)		180	190		kg
Degrees of protection of electrical equipment (EN 60529)		IP 54			
Colour		RAL 7035   different colours available on request			

For additional models, options and voltages visit [www.pfannenberg.com](http://www.pfannenberg.com) or contact us directly.

<sup>1</sup> performance data based on 50 Hz operation



**Performance curves on page 178.**

The performance curves do include standard pump losses and refer to 50 Hz and 20 % glycol mixtures. For a 40 °C ambient temperature you can expect capacity values shown for 32 °C to decrease by 20 %. For a 45 °C ambient temperature you can expect capacity values shown for 32 °C to decrease by 30 %.



Comprehensive technical documentation such as

- operating instruction, technical data, approvals
- cut-out drawing, CAD | EPLAN | Zuken | WSCAD data

can be retrieved by entering this webcode in the search window on [www.pfannenberg.com](http://www.pfannenberg.com)

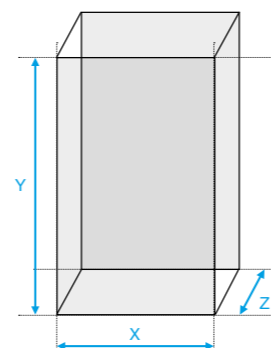

## EB 2.0 WT – Configurations

Easily find the right product.

PRODUCT CHARACTERISTIC	CONFIGURATION					
	BASIC	H	S	HS	SP	HSP
Hydraulic Protection H	–	+	–	+	–	+
Smart Cooling S	–	–	+	+	+	+
Precision Cooling P	–	–	–	–	+	+

### Product characteristic Hydraulic Protection (H)

Provides additional hydraulic features for protection of the system.

- Adjustable flow switch provides an alarm if volume flow is too low.
- Water level check protects pump from damage caused by dry running.
- Hydraulic bypass: protects pump by ensuring minimum flow and protects the application by limiting the system pressure.

### Product characteristic Smart Cooling (S)

Offers advanced temperature control and error detection.

- Optional differential temperature control: takes into account ambient temperature when the application has increased requirements regarding condensation and elongation.
- Temperature alarm  $T_{min}/T_{max}$  detects an unexpected increase or drop in temperature of the cooling fluid.
- Error message panel: very important for service and troubleshooting. Provides differentiated error codes (on common alarm signal).

*Please note: For single alarm messages and communication with a superior external control an additional RS 485 interface is needed.*

Some errors occur if the chiller needs service: error code and data logging helps to achieve fast and effective elimination of faults and preventive maintenance. Some errors can occur in your system even if the chiller is working properly:

- Flow alarm – volume flow of the cooling fluid of the application is out of range.
- Temperature alarm – chiller detects irregularities in the temperature profile.

### Product characteristic Precision Cooling (P)

Limits deviation from target temp to ±1 K (must be combined with product characteristic S).

- Hot gas bypass: Improves accuracy of temperature control without stressing the compressor by frequent on/off switching (operation >50 % of nominal power required).
- Fan on/off: improves accuracy of temperature control by influencing the performance of the condenser unit.

*Please note: Variable fan speed is only available for customised chillers with EC fans.*

# EB 2.0 L Chillers 21–44 kW

**NEW**

Specifically developed to meet the demanding requirements of today's industrial applications, the EB 2.0 L chillers allow higher cooling capacities in the smallest possible footprint. With a long list of standard features and many available options, Pfannenberg's EB series provides the best choice for cooling of machinery of any kind.

**Powerful basic equipment**

High-quality controllers enable numerous additional functions and error detection.

**Numerous options**

Many optional features including advanced sensors, communication and industrial connectors.

**Flexible power supply**

Possible use in different voltages. E.g. 400 V 50 Hz and 460 V 60 Hz.

**Environmentally friendly**

Thanks to microchannel technology the content of refrigerants is kept to a minimum in the refrigeration circuit.

**CE and UL certification**

Certified to CE and UL508a as a standard.

**Cooling medium**

Water | water/glycol mixtures.

**Robust industry standard**

Steel housing with thick powder coating.



**High performance fans**

Huge airflow to guarantee operation even at high ambient conditions.

## CHILLERS 21–26 kW

protection system	water   water/glycol	small hysteresis	microchannel technology
RAL 7035	different RAL available	enhanced pump	service friendly



PRODUCT	EB L 210 WT	EB L 260 WT	Unit	
ARTICLE NO.	42032105001	42032605001		
<b>DATA</b>				
Rated voltage	50   60		Hz ±1 %	
	400 3~   460 3~		V ±10 %	
Cooling capacity (with pump)	W18/A32	21.3   23.4	25.7   28.5	kW
Flow rate (pump) <sup>1</sup>		54   64	70   84	l/min
Pump pressure		2.5		bar
Ambient temperature		+15 ... +45	+15 ... +43	°C
Medium		water   water/glycol		
Medium temperature (outlet)		+13 ... +30   factory setting +18		°C
Target value tolerance		±2		K
Refrigerant		R407C		
Max power consumption		9.9   12.6	12.1   14.2	kW
Max current consumption		20   22	22   22.5	A
Starting current		72.8   80.5	89.9   98.7	
Control voltage		AC 24		V
Airflow <sup>1</sup>	external	7000		m³/h
Tank volume		70		l
Connections (medium)	IG	1 1/4"		BSP
Dimensions (X x Y x Z)		1230 x 1410 x 790		mm
Weight (net)		389	403	kg
Degrees of protection of electrical equipment (EN 60529)		IP 54		
Colour		RAL 7035   different colours available on request		

For additional models, options and voltages visit [www.pfannenberg.com](http://www.pfannenberg.com) or contact us directly.

<sup>1</sup> performance data based on 50/60 Hz operation



Performance curves on page 178.



Comprehensive technical documentation such as

- operating instruction, technical data, approvals
- cut-out drawing, CAD | EPLAN | Zuken | WSCAD data

can be retrieved by entering this webcode in the search window on [www.pfannenberg.com](http://www.pfannenberg.com)

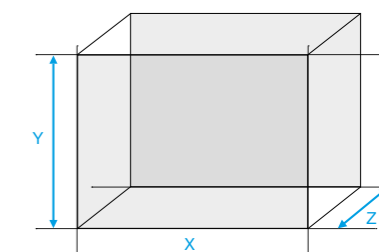

### CHILLERS 31–36 kW

- protection system
- water | water/glycol
- small hysteresis
- microchannel technology
- RAL 7035
- different RAL available
- enhanced pump
- service friendly



PRODUCT	EB L 310 WT	EB L 360 WT	
ARTICLE NO.	42033105001	42033605001	Unit
DATA			
Rated voltage	50   60		Hz ±1 %
	400 3~   460 3~		V ±10 %
Cooling capacity (with pump)	W18/A32 30.6   36.7	35.6   42.7	kW
Flow rate (pump) <sup>1</sup>	82   98	90   107	l/min
Pump pressure	2.5		bar
Ambient temperature	+15 ... +45		°C
Medium	water   water/glycol		
Medium temperature (outlet)	+13 ... +30   factory setting +18		°C
Target value tolerance	±2		K
Refrigerant	R407C		
Max power consumption	17.4   22.2	17.9   20.6	kW
Max current consumption	31   33	30   31	A
Starting current	127   132	123   126	
Control voltage	AC 24		V
Airflow <sup>1</sup>	external	12000	m <sup>3</sup> /h
Tank volume	200		l
Connections (medium)	IG	1 1/2"	BSP
Dimensions (X x Y x Z)	1680 x 1410 x 790		mm
Weight (net)	434	448	kg
Degrees of protection of electrical equipment (EN 60529)	IP 54		
Colour	RAL 7035   different colours available on request		

For additional models, options and voltages visit [www.pfannenberg.com](http://www.pfannenberg.com) or contact us directly.

<sup>1</sup> performance data based on 50/60 Hz operation

Performance curves on page 178.



Comprehensive technical documentation such as

- operating instruction, technical data, approvals
- cut-out drawing, CAD | EPLAN | Zuken | WSCAD data

can be retrieved by entering this webcode in the search window on [www.pfannenberg.com](http://www.pfannenberg.com)

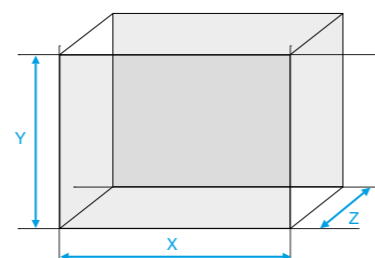

### CHILLERS 41–44 kW

- protection system
- water | water/glycol
- small hysteresis
- microchannel technology
- RAL 7035
- different RAL available
- enhanced pump
- service friendly



PRODUCT	EB L 410 WT	EB L 440 WT	
ARTICLE NO.	42034105001	42034405001	Unit
DATA			
Rated voltage	50   60		Hz ±1 %
	400 3~   460 3~		V ±10 %
Cooling capacity (with pump)	W18/A32 40.5   48.5	43.5   52.2	kW
Flow rate (pump) <sup>1</sup>	105   125	105   125	l/min
Pump pressure	2.5		bar
Ambient temperature	+15 ... +43		°C
Medium	water   water/glycol		
Medium temperature (outlet)	+13 ... +30   factory setting +18		°C
Target value tolerance	±2		K
Refrigerant	R407C		
Max power consumption	18.1   21.8	19.1   23	kW
Max current consumption	31.5   33	34.5   35	A
Starting current	131   135	143   147	
Control voltage	AC 24		V
Airflow <sup>1</sup>	external	12000	m <sup>3</sup> /h
Tank volume	200		l
Connections (medium)	IG	1 1/2"	BSP
Dimensions (X x Y x Z)	1680 x 1410 x 790		mm
Weight (net)	476	500	kg
Degrees of protection of electrical equipment (EN 60529)	IP 54		
Colour	RAL 7035   different colours available on request		

For additional models, options and voltages visit [www.pfannenberg.com](http://www.pfannenberg.com) or contact us directly.

<sup>1</sup> performance data based on 50/60 Hz operation

Performance curves on page 179.



Comprehensive technical documentation such as

- operating instruction, technical data, approvals
- cut-out drawing, CAD | EPLAN | Zuken | WSCAD data

can be retrieved by entering this webcode in the search window on [www.pfannenberg.com](http://www.pfannenberg.com)

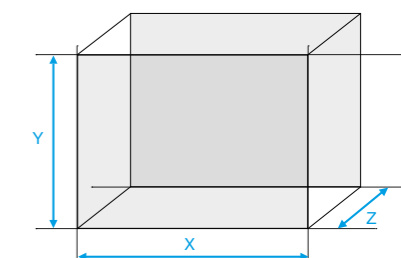

# EB XT Chillers 36–150 kW

Pfannenberg introduced a new product series to extend our portfolio with a new extreme performance range up to 150 kW in cooling capacity. The EB XT consists of nine units in three different housing sizes following our high-level standards in efficiency, compact design and innovation in chiller technology.

**Extreme cooling capacities**  
extending our range of chillers up to new high cooling capacities.

**EC fans**  
Variable speed control, EC motor technology, further increasing energy savings.

**Scroll compressor**  
Lower noise level and 20 % decreased power consumption than comparable piston compressors.

**Cooling medium**  
Water | water/glycol mixtures.



**Microchannel technology**  
Using microchannel heat exchangers (MCHX) for condenser coil design allows more efficient and compact solution.

**Controller and sensor technology**  
Controller system and digital display of temperature, pressure, tank level and status values.

**Electronic expansion valve**  
Operates with a much more sophisticated design allowing a superior control resolution in high peak/low peak applications.

**Reduced emissions**  
due to high efficiency refrigerant R410A.

## CHILLERS 36.5–58.6 kW

protection system	water   water/glycol	microchannel technology	small hysteresis	extreme T conditions
large tank	RAL 7035	different RAL available	enhanced pump	service friendly
top EER/energy saving	laser applications	EC fan		



PRODUCT	EB XT 400 WT	EB XT 500 WT	EB XT 600 WT	Unit	
ARTICLE NO.	42144005001	42145005001	42146005001		
<b>DATA</b>					
Rated voltage	50			Hz ±1 %	
	400 3~			V ±10 %	
Cooling capacity (with pump)	W15/A32	36.5	47.3	58.6	kW
Flow rate (pump)		117	150	183	l/min
Pump pressure		3.0			bar
Ambient temperature		+5 ... +50			°C
Medium		water   water/glycol			
Medium temperature (outlet)		+8 ... +30			°C
Target value tolerance		±1			K
Refrigerant		R410A			
Power consumption (with pump)	W15/A32	12.8	15.7	21	kW
Full load amperage		23.1	28.3	37.9	A
Airflow	external	9350	12600	20000	m³/h
Tank volume		300			l
Connections (medium)	IG	1 1/2"			BSP
Dimensions (X x Y x Z)		830 x 2030 x 1240			mm
Weight (net)		540	550	620	kg
Degrees of protection of electrical equipment (EN 60529)		IP 54			
Colour		RAL 7035   different colours available on request			

For additional models, options and voltages visit [www.pfannenberg.com](http://www.pfannenberg.com) or contact us directly.



Performance curves on page 179.

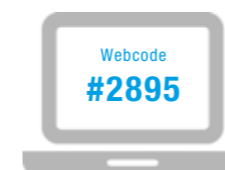

Comprehensive technical documentation such as

- operating instruction, technical data, approvals
- cut-out drawing, CAD | EPLAN | Zuken | WSCAD data

can be retrieved by entering this webcode in the search window on [www.pfannenberg.com](http://www.pfannenberg.com)

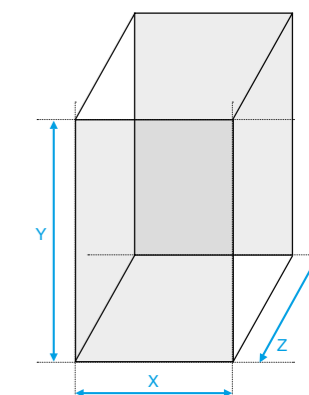

## CHILLERS 66.5–94.9 kW

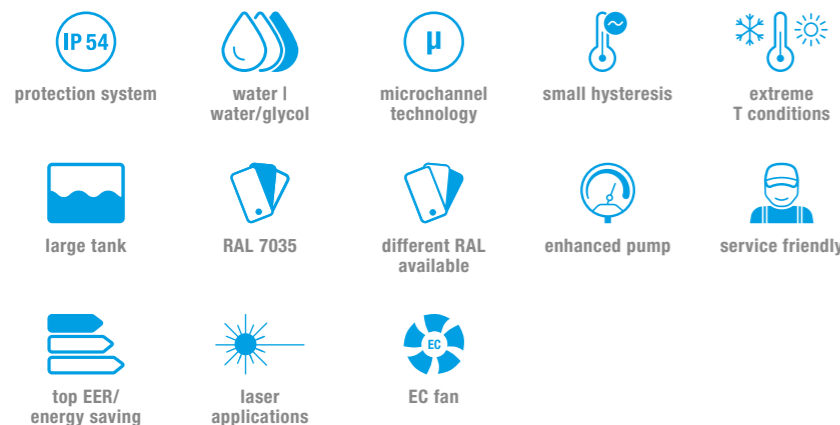

PRODUCT	EB XT 700 WT	EB XT 800 WT	EB XT 900 WT	EB XT 1000 WT	
ARTICLE NO.	42147005001	42148005001	42149005001	42151005001	Unit

DATA						
Rated voltage		50				Hz ±1 %
		400 3~				V ±10 %
Cooling capacity (with pump)	W15/A32	66.5	74.2	82.1	94.9	kW
Flow rate (pump)		200	233	267	300	l/min
Pump pressure		3.0				bar
Ambient temperature		+5 ... +50				°C
Medium		water   water/glycol				
Medium temperature (outlet)		+8 ... +30				°C
Target value tolerance		±1				K
Refrigerant		R410A				
Power consumption (with pump)	W15/A32	20.3	25.2	28	32.5	kW
Full load amperage		36.6	45.5	50.5	58.6	A
Airflow	external	23270				m³/h
Tank volume		500				l
Connections (medium)	IG	2"				BSP
Dimensions (X x Y x Z)		830 x 2030 x 1840				mm
Weight (net)		650	650	700	720	kg
Degrees of protection of electrical equipment (EN 60529)		IP 54				
Colour		RAL 7035   different colours available on request				

For additional models, options and voltages visit [www.pfannenberg.com](http://www.pfannenberg.com) or contact us directly.



Performance curves on page 179–180.



Comprehensive technical documentation such as

- operating instruction, technical data, approvals
- cut-out drawing, CAD | EPLAN | Zuken | WSCAD data

can be retrieved by entering this webcode in the search window on [www.pfannenberg.com](http://www.pfannenberg.com)

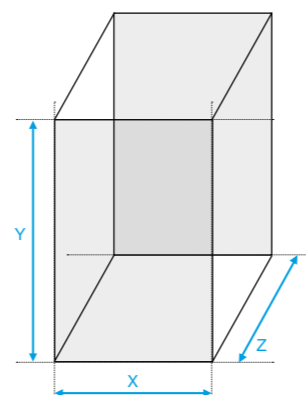

## CHILLERS 115.8–148.8 kW

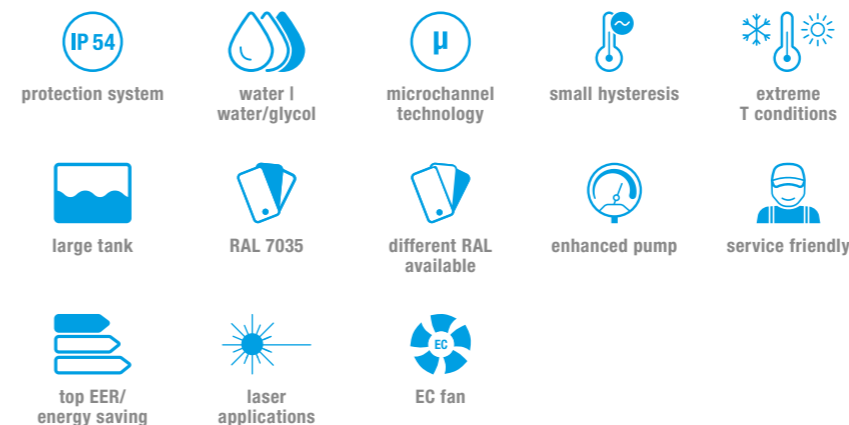

PRODUCT	EB XT 1200 WT	EB XT 1600 WT	
ARTICLE NO.	42151205001	42151605001	Unit

DATA					
Rated voltage		50			Hz ±1 %
		400 3~			V ±10 %
Cooling capacity (with pump)	W15/A32	115.8	148.8		kW
Flow rate (pump)		333	367		l/min
Pump pressure		3.0			bar
Ambient temperature		+5 ... +50			°C
Medium		water   water/glycol			
Medium temperature (outlet)		+8 ... +30			°C
Target value tolerance		±1			K
Refrigerant		R410A			
Power consumption (with pump)	W15/A32	36.6	47.1		kW
Full load amperage		66	85		A
Airflow	external	45550			m³/h
Tank volume		700			l
Connections (medium)	IG	DN 65			BSP
Dimensions (X x Y x Z)		1200 x 2030 x 2665			mm
Weight (net)		1100	1200		kg
Degrees of protection of electrical equipment (EN 60529)		IP 54			
Colour		RAL 7035   different colours available on request			

For additional models, options and voltages visit [www.pfannenberg.com](http://www.pfannenberg.com) or contact us directly.



Performance curves on page 180.



Comprehensive technical documentation such as

- operating instruction, technical data, approvals
- cut-out drawing, CAD | EPLAN | Zuken | WSCAD data

can be retrieved by entering this webcode in the search window on [www.pfannenberg.com](http://www.pfannenberg.com)

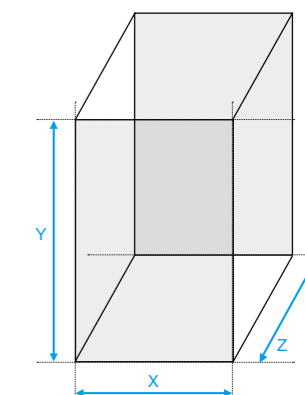

# EB 2.0 OL Chillers 3.2–16 kW

Technology flexibility and performance common to all EB series are available also to all the applications in which the cooling liquid is oil or an emulsion with high viscosity, mainly in tool machine industry. Taking into account the typical market requirements, the units are available also without pumps as standard units.

**Microchannel technology**  
Using microchannel heat exchangers (MCHX) for condenser coil design allows more efficient and compact solution.

**Highly customisable**  
Many optional features including hot gas bypass, flow switch and aluminium filter.

**Cooling medium**  
Oils | high viscosity mixtures from 22 to 68 cSt @ +40 °C.

**Ambient conditions**  
Suitable for environment temperatures up to +45 °C.



**Robust industry standard**  
Steel housing with thick powder coating, for indoor use.

**Environment friendly**  
due to high efficiency refrigerant R410A (R407C for smaller units).

**Extremely versatile**  
Units for operation with external pump (on site).

**Fast available solution**  
Units with standard pumps included.

## CHILLERS 3.2–4.4 kW

protection system	oil	high viscosity oil	small hysteresis
RAL 7035	different RAL available	enhanced pump available	service friendly



PRODUCT		EB 32 OL	EB 44 OL	
ARTICLE NO.	NO PUMP	43030325001	43030445001	Unit
ARTICLE NO.	WITH PUMP	43030325002	43030445002	

DATA				
Rated voltage		AC 50		Hz ±1 %
		400 3~		V ±10 %
Cooling capacity (with pump)	O26/A32	3.2	4.4	kW
Required flow rate (pump) <sup>2</sup>		10	16	l/min
Max. pump pressure		10		bar
Ambient temperature		+15 ... +45		°C
Medium		oil (viscosity 22 cSt to 68 cSt @ +40 °C)		
Medium temperature (outlet)		+20 ... +35   factory setting +26		°C
Target value tolerance		±2		K
Refrigerant	R407C	1100	1200	g
Max power consumption		1.8		kW
Max current consumption	no pump	4.5		A
Starting current		18.9		
Max. power consumption		1.9	2.4	kW
Max. current consumption	with pump	5.0	6.0	A
Starting current		21	25.2	
Control voltage		AC 24		V
Airflow <sup>1</sup>	external	2500		m <sup>3</sup> /h
Connections (medium)	IG	1/2"		BSP
Dimensions (X x Y x Z)		606 x 1254 x 764		mm
Weight (net)		120	125	kg
Degrees of protection of electrical equipment (EN 60529)		IP 54		
Colour		RAL 7035   different colours available on request		

For additional models, options and voltages visit [www.pfannenberg.com](http://www.pfannenberg.com) or contact us directly.

<sup>1</sup> performance data based on 50 Hz operation  
<sup>2</sup> required flow rate – standard unit without pump



Performance curves on page 180–181.



Comprehensive technical documentation such as

- operating instruction, technical data, approvals
- cut-out drawing, CAD | EPLAN | Zuken | WSCAD data

can be retrieved by entering this webcode in the search window on [www.pfannenberg.com](http://www.pfannenberg.com)

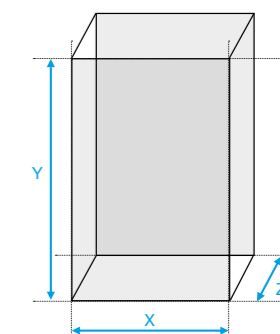

## CHILLERS 6.5–9.5 kW



PRODUCT		EB 65 OL	EB 80 OL	EB 95 OL	
ARTICLE NO.	NO PUMP	43030655001	43030805001	43030955001	Unit
ARTICLE NO.	WITH PUMP	43030655002	43030805002	43030955002	

DATA					
Rated voltage	no pump	AC 50   60 400 3~   460 3~			Hz ±1 % V ±10 %
	with pump	AC 50 400 3~			Hz ±1 % V ±10 %
Cooling capacity (with pump)	026/A32	6.5	8.0	9.5	kW
Required flow rate (pump) <sup>2</sup>		25	25	45	l/min
Max. pump pressure		10			bar
Ambient temperature		+15 ... +45			°C
Medium		oil (viscosity 22 cSt to 68 cSt @ +40 °C)			
Medium temperature (outlet)		+20 ... +35   factory setting +26			°C
Target value tolerance		±2			K
Refrigerant	R410A	2150	2500		g
Max power consumption	no pump	2.6   3.3	3.1   3.9	3.5   4.5	kW
Max current consumption		5.5   6.0	6.5   7.0	7.0   7.5	A
Starting current	with pump	23.1   25.2	27.3   25.2	29.4   31.5	A
Max. power consumption		4.1	4.6	5.0	kW
Max. current consumption	with pump	9.5	10	11	A
Starting current		39.9	42	46.2	A
Control voltage		AC 24			V
Airflow <sup>1</sup>	external	4000		5000	m <sup>3</sup> /h
Connections (medium)	IG	3/4"			BSP
Dimensions (X x Y x Z)		606 x 1254 x 764			mm
Weight (net)		140	150	160	kg
Degrees of protection of electrical equipment (EN 60529)		IP 54			
Colour		RAL 7035   different colours available on request			

For additional models, options and voltages visit [www.pfannenberg.com](http://www.pfannenberg.com) or contact us directly.

<sup>1</sup> performance data based on 50 Hz operation  
<sup>2</sup> required flow rate – standard unit without pump



Performance curves on page 181.



Comprehensive technical documentation such as

- operating instruction, technical data, approvals
- cut-out drawing, CAD | EPLAN | Zuken | WSCAD data

can be retrieved by entering this webcode in the search window on [www.pfannenberg.com](http://www.pfannenberg.com)

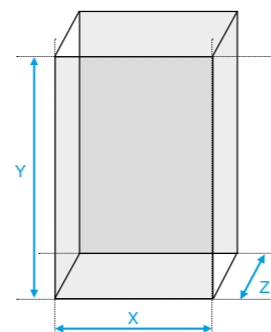

## CHILLERS 14–16 kW



PRODUCT		EB 140 OL	EB 160 OL	
ARTICLE NO.	NO PUMP	43031405002	43031605001	Unit
ARTICLE NO.	WITH PUMP	43031405003	43031605002	

DATA					
Rated voltage	no pump	AC 50   60 400 3~   460 3~			Hz ±1 % V ±10 %
	with pump	AC 50 400 3~			Hz ±1 % V ±10 %
Cooling capacity (with pump)	026/A32	14	16		kW
Required flow rate (pump) <sup>2</sup>		65			l/min
Max. pump pressure		10			bar
Ambient temperature		+15 ... +45			°C
Medium		oil (viscosity 22 cSt to 68 cSt @ +40 °C)			
Medium temperature (outlet)		+20 ... +35   factory setting +26			°C
Target value tolerance		±2			K
Refrigerant	R410A	3300	6100		g
Max power consumption	no pump	5.4   5.1	6.5   7.8		kW
Max current consumption		9.5   9.5	12   13		A
Starting current	with pump	39.9   39.9	52.5   54		A
Max. power consumption		7.6	9.7		kW
Max. current consumption	with pump	15	18		A
Starting current		63	75.6		A
Control voltage		AC 24			V
Airflow <sup>1</sup>	external	7500		7500	m <sup>3</sup> /h
Connections (medium)	IG	1"			BSP
Dimensions (X x Y x Z)		856 x 1435 x 761			mm
Weight (net)		180	190		kg
Degrees of protection of electrical equipment (EN 60529)		IP 54			
Colour		RAL 7035   different colours available on request			

For additional models, options and voltages visit [www.pfannenberg.com](http://www.pfannenberg.com) or contact us directly.

<sup>1</sup> performance data based on 50 Hz operation  
<sup>2</sup> required flow rate – standard unit without pump



Performance curves on page 181.



Comprehensive technical documentation such as

- operating instruction, technical data, approvals
- cut-out drawing, CAD | EPLAN | Zuken | WSCAD data

can be retrieved by entering this webcode in the search window on [www.pfannenberg.com](http://www.pfannenberg.com)

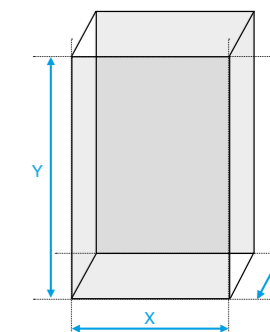

# PWW

## Passive Cooling System

### 9–24 kW

Because PWW chillers are cooling with process water instead of active refrigeration circuit they are used in applications like automotive production where process water is available. The units are designed for operation at water temperatures up to 30 °C.

#### Passive cooling system

Due to the smart design of the closed loop circuit PWW units can be easily adapted to the existing water supply.

#### Service friendly design

Easy removable panels allow quick access to internal components and reduced service cost.

#### 3-way valve for primary water regulation

Means the highest reliability, complete accuracy, wide temperature control range and programmable set-point.

#### Plate heat exchanger

made of stainless steel to prevent corrosion and grant high performance.

#### Centrifugal pump

Multi stage pump for high flow rates even at high pressure resistance.

#### Expansion vessel

A properly sized thermal expansion tank will accommodate the additional volume of water created through expansion during the heating cycle.

#### Digital controller

with clear error message and easily editable set point.



## PUMP PRESSURE

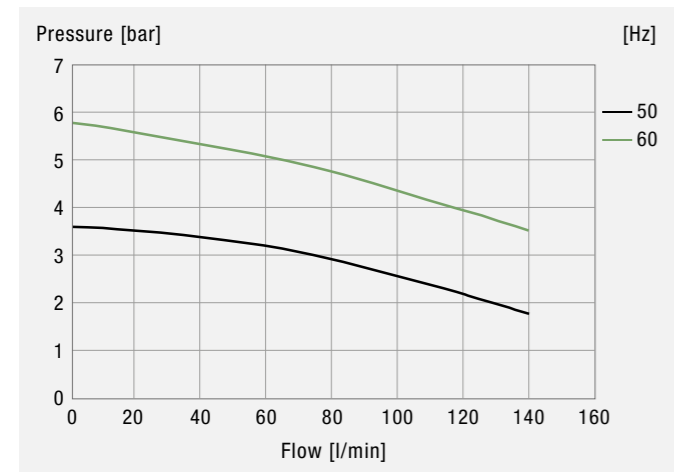

## CHILLERS 9–24 kW

- protection system
- water | water/glycol
- passive cooling system
- closed loop
- RAL 7035
- different RAL available
- service friendly
- top EER/energy saving



PRODUCT	PWW 9.000	PWW 12.000	PWW 18.000	PWW 24.000		
ARTICLE NO.	42120905001	42121205001	42121805001	42122405001	Unit	
<b>DATA</b>						
Rated voltage	50   60				Hz ±1 %	
	230 1~		400 3~   460 3~		V ±10 %	
Cooling capacity	WP15/WS20	9.0	12	18	24	kW
	WP15/WS25	18	24	36	48	
Primary water inlet	temperature	+5 ... +30			°C	
	flow rate	min. 15	min. 18	min. 25	min. 35	l/min
	pressure	min. 1.5				bar
Secondary water outlet	temperature	+10 ... +35   factory setting +20			°C	
	flow rate	22	22	27	45	l/min
	pressure	3.0				bar
Ambient temperature	+10 ... +45		+10 ... +50		°C	
Target value tolerance	±2				K	
Max power consumption	1720   2610				W	
Max current consumption	4.4   4.4				A	
Starting current	18   18					
Connections (medium)	IG	3/4"		1"	BSP	
Dimensions (X x Y x Z)	580 x 475 x 580				mm	
Weight (net)	50	53	60	65	kg	
Degrees of protection of electrical equipment (EN 60529)	IP 54					
Colour	RAL 7035   different colours available on request					

For additional models, options and voltages visit [www.pfannenberg.com](http://www.pfannenberg.com) or contact us directly.

Cooling capacity included power loss in the pump; WP: primary water inlet temperature | WS: secondary water outlet temperature; capacity calculated at standard flow rate for secondary and minimum flow rate for primary side. Water inlet temperature in the primary circuit must be minimum 5 °C below the water outlet temperature in the secondary circuit.

EAC CE

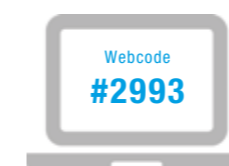

Comprehensive technical documentation such as

- operating instruction, technical data, approvals
- cut-out drawing, CAD | EPLAN | Zuken | WSCAD data

can be retrieved by entering this webcode in the search window on [www.pfannenberg.com](http://www.pfannenberg.com)

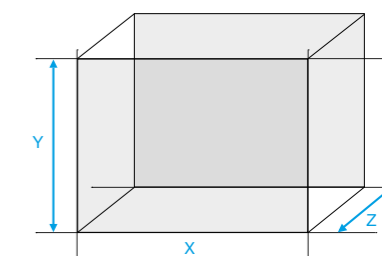

# Life insurance.

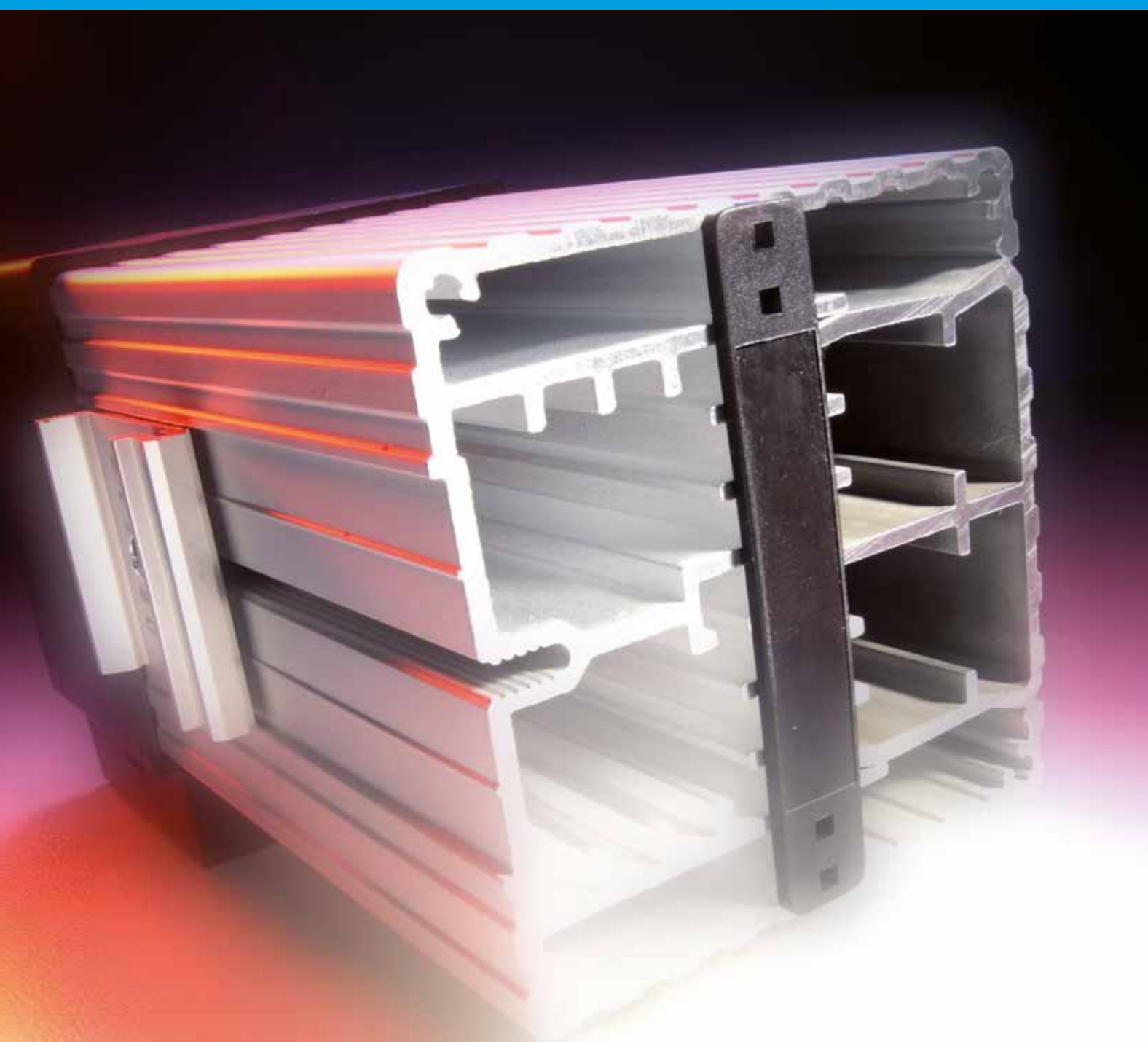

## Heaters, Thermostats and Hygrostats.

The formation of condensation is one of the largest dangers for electrical enclosures. As long as they are working under load, the heat dissipation from the components will prevent any condensation from forming within the enclosure. When there is no longer any heat load due to system downtime, there is a potential danger that components within the cabinet will form condensation. And this is precisely where the function of the Pfannenberg control cabinet heaters begins (radiant heaters and fan heaters). With the addition of the PFH-T series, which is a collection of fan heaters with an internal thermostat for the regulation of the fan and heater, prevention of condensation in the cabinet is guaranteed.

Various performance classes of FLH control cabinet heaters are ideally complemented by thermostats and hygrostats from the FLZ series. Combined, they ensure that the temperature inside the control cabinet is always correct and that the formation of condensation is prevented.

The control of 4th generation filterfans by thermostats from the FLZ series represents an intelligent use of filterfans for control cabinet air conditioning to suit individual needs. It increases energy efficiency and reduces CO<sub>2</sub> emissions. Accordingly, the combination with thermostats and hygrostats offers a better environmental balance through higher energy efficiency. It also results in greater reliability of your production process.

Pfannenberg's heaters, thermostats and hygrostats perfectly complement Pfannenberg's filterfans, heat exchangers and cooling units.

Protecting man, machine and the environment.

## 6 different heating series: Always the right solution.



### PRH-M – Mini-Radiant Heaters.

- For very compact housings.
- Heating at certain points.
- For small heating requirements.



### FLH – Radiant Heaters.

- Standard radiant heating for all applications.
- Wide performance range according to the application.
- Various connection possibilities.
- Ideal for small housings.



### FLH LST – Surface temperature-limited Radiant Heaters.

- Radiant heaters with temperature limitation of the radiator surface.
- Wide performance range according to the application.
- Ideal for small housings.



### FLH SL – Fan Heaters.

- With railway certification for all sectors with increased shock and vibration requirements, (wind energy, mobile).
- Ideal also for outdoor applications; starts up to  $-40\text{ }^{\circ}\text{C}$ .
- With classical screw fastening.



### FLH-T – Fan Heaters with integrated Thermostat.

- With railway certification for all sectors with increased shock and vibration requirements (wind, telecom, train).
- Integrated thermostat for automatic control.
- Ball bearing fan for long service life.
- Plastic housing for safe operation.



### PFH – Compact Fan Heaters.

- New fan heater; standard solution with PTC for all electrical enclosures.
- Very compact construction, especially for smaller housings.
- Due to quick heating-up, especially where the plant needs to start up quickly (wind).
- Plastic housing for safe operation.



### PFH-T – Compact Fan Heaters with integrated Thermostat.

- Like PFH, but with integrated thermostat.
- Same application – but no additional space for thermostat necessary.
- Energy-saving automatic temperature control.
- Plastic housing for safe operation.

## 3 different thermostat and hygrostat series: For every application.



### FLZ 510–530 – Thermostats.

- The standard solution to control heaters and filterfans.
- All applications in industry.
- Protects heating and fan.



### FLZ 541–543 – Twin Thermostats.

- Combination for reduced space requirements.
- All applications in industry.
- Switching units in various temperature ranges.



### FLZ 600–610 – Hygrostats.

- Humidity control, all applications in industry.
- Best for environments with high air humidity.
- Protection against condensate before it occurs.

## Heaters at a glance

TYPE	HEATING PERFORMANCE	RATED VOLTAGE	DIMENSIONS (HxWxD)	APPROVALS					PAGE
				cURus	UR	EAC	CSA	CE	
<b>FLH Radiant Heaters</b>									
FLH 015	15 W	230 V AC <sup>1</sup>	100 x 70 x 50 mm	●		●		●	145
FLH 030	30 W			●		●		●	
FLH 045	45 W			●		●		●	
FLH 060	60 W			●		●		●	
FLH 075	75 W		175 x 70 x 50 mm	●		●		●	
FLH 100	100 W			●		●		●	
FLH 150	150 W			●		●		●	
				250 x 70 x 50 mm	●		●		
<b>FLH LST Surface temperature-limited Radiant Heaters</b>									
FLH 020 LST	20 W	230 V AC <sup>1</sup>	132 x 70 x 50	●		●		●	146
FLH 030 LST	30 W		177 x 70 x 50	●		●		●	
FLH 050 LST	50 W		252 x 70 x 50	●		●		●	
<b>PRH-M Mini-Radiant Heaters</b>									
PRH 010-M	10 W	230 V AC <sup>1</sup>	45 x 75 x 29.5 mm		●	●		●	147
PRH 020-M	20 W			●	●		●		
PRH 030-M	30 W			●	●		●		
<b>FLH Fan Heaters</b>									
FLH 250	250 W	230 V AC	186.5 x 85 x 104 mm	●		●		●	148
FLH 400	400 W		226.5 x 85 x 104 mm	●		●		●	
FLH 250 SL	250 W		170.5 x 126 x 105 mm	●				●	
<b>FLH-T Fan Heaters with integrated thermostat</b>									
FLH-T 250	250 W	230 V AC	100 x 150 x 164 mm		●	●		●	150
FLH-T 400	400 W			●	●		●		
FLH-T 600	600 W			●	●		●		
FLH-T 800	800 W			●	●		●	151	
FLH-T 1000	1000 W			●	●		●		
<b>PFH Compact Fan Heaters</b>									
PFH 200	200 W	230 V AC	142 x 88 x 126 mm	●		●	○	●	152
PFH 300	300 W			●		●	○	●	
PFH 400	400 W			●		●	○	●	
PFH 500	500 W			●		●	○	●	
PFH 650	650 W			●		●	○	●	
PFH 800	800 W			●		●	○	●	
PFH 1000	1000 W			●		●	○	●	
PFH 1200	1200 W			●		●	○	●	
<b>PFH-T Compact Fan Heaters with integrated thermostat</b>									
PFH-T 200	200 W	230 V AC	142 x 88 x 139 mm	●		○	○	●	153
PFH-T 300	300 W			●		○	○	●	
PFH-T 400	400 W			●		○	○	●	
PFH-T 500	500 W			●		○	○	●	
PFH-T 650	650 W			●		○	○	●	
PFH-T 800	800 W			●		○	○	●	
PFH-T 1000	1000 W			●		○	○	●	
PFH-T 1200	1200 W			●		○	○	●	

For additional models, options and voltages visit [www.pfannenberg.com](http://www.pfannenberg.com) or contact us directly.

<sup>1</sup> voltage range 110–250 V AC

● available ○ pending

## Thermostats and Hygrostats at a glance

TYPE	RATED VOLTAGE	DIMENSIONS (HxWxD)	APPROVALS				PAGE
			cURus	EAC	CSA	CE	
<b>FLZ Thermostats</b>							
FLZ 510	AC/DC	59.5 x 37 x 47.5 mm	●	●		●	154
FLZ 520		72 x 40 x 36 mm	●	●	●	●	
FLZ 530			●	●	●	●	
<b>FLZ Twin Thermostats</b>							
FLZ 541	AC/DC	80.5 x 59 x 38 mm	●	●		●	155
FLZ 542			●	●		●	
FLZ 543			●	●		●	
<b>FLZ Hygrostats</b>							
FLZ 600	AC/DC	60 x 37 x 47 mm	●	●		●	156
FLZ 610		80.5 x 59 x 38 mm	●	●		●	

For additional models, options and voltages visit [www.pfannenberg.com](http://www.pfannenberg.com) or contact us directly.

● available ○ pending

# FLH Radiant Heaters

## 15–150 Watt

Radiant heaters are built very compactly and cover a wide operating range.

**Mounting**  
Integrated snap fastening for 35 mm DIN-rail.

**Long life**  
and robust construction without fan.

**Applications**  
Predominantly used in control cabinets for the avoidance of excessively low temperatures or excessively high relative humidity.



**Safe protection**  
against condensate forming in the cabinet by means of fast heating due to PTC technology.

**Different performance ratings**  
ensure that the correct heating power is always available. The total heat necessary can be distributed according to the needs.

**Electrical connection**  
Depending on the existing connecting conditions, options are available with a 500 mm connecting cable or a plug terminal connector.

## RADIANT HEATERS 30–150 W

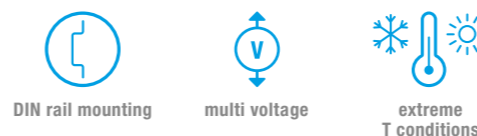

PRODUCT	FLH 015	FLH 030	FLH 045	FLH 060	
ARTICLE NO.	17001505007	17003005007	17004505007	17006005007	Unit
DATA					
Heating performance (Ta = +20 °C)	15	30	45	60	W
Rated voltage ±10 %	AC 50   60 Hz				
	230				V
Functional range	110–250 V AC 50   60 Hz				
Max. starting current	1.1	1.2	1.8	2.5	A
Max. surface temperature	65	90	105	105	°C
Operating temperature	–40 ... +70				
Type of mounting	snap fastening for 35 mm profile bars according to EN 60715				
Type of connection	plug terminal connector				
Dimensions (X x Y x Z)	70 x 100 x 50			70 x 175 x 50	mm

PRODUCT	FLH 075	FLH 100	FLH 150	
ARTICLE NO.	17007505007	17010005007	17015005007	Unit
DATA				
Heating performance (Ta = +20 °C)	75	100	150	W
Rated voltage ±10 %	AC 50   60 Hz			
	230			V
Functional range	110–250 V AC 50   60 Hz			
Max. starting current	4.5	5	7.5	A
Max. surface temperature	120	130	150	°C
Operating temperature	–40 ... +70			
Type of mounting	snap fastening for 35 mm profile bars according to EN 60715			
Type of connection	plug terminal connector			
Dimensions (X x Y x Z)	70 x 175 x 50		70 x 250 x 50	mm

ACCESSORIES	ARTICLE NUMBER	Page
Thermostat	17111000000	154
Hygostat	17207000000	156
Internal enclosure fan	18110000000	39

For additional models, options and voltages visit [www.pfannenberg.com](http://www.pfannenberg.com) or contact us directly.

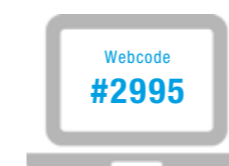

Comprehensive technical documentation such as

- operating instruction, technical data, approvals
- cut-out drawing, CAD | EPLAN | Zuken | WSCAD data

can be retrieved by entering this webcode in the search window on [www.pfannenberg.com](http://www.pfannenberg.com)

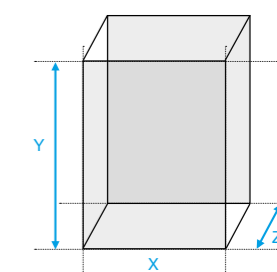

## SURFACE TEMPERATURE-LIMITED RADIANT HEATERS 20–50 W

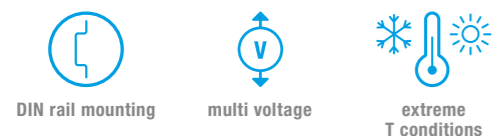

PRODUCT	FLH 020 LST	FLH 030 LST	FLH 050 LST	
ARTICLE NO.	17002105007	17003105007	17005105007	Unit

DATA				
Heating performance (Ta = +20 °C)	20	30	50	W
Rated voltage ±10 %	AC 50   60 Hz			
	230			V
Functional range	110–250 V AC 50   60 Hz			
Max. starting current	1.1	1.2	2.3	A
Max. surface temperature	55 <sup>1</sup>			°C
Operating temperature	–40 ... +70			
Type of mounting	snap fastening for 35 mm profile bars according to EN 60715			
Type of connection	plug terminal connector			
Dimensions (X x Y x Z)	70 x 132 x 50	70 x 177 x 50	70 x 252 x 50	mm

ACCESSORIES	ARTICLE NUMBER	Page
Thermostat	17111000000	154
Hygostat	17207000000	156
Internal enclosure fan	18110000000	39

For additional models, options and voltages visit [www.pfannenberg.com](http://www.pfannenberg.com) or contact us directly.

<sup>1</sup> surface temperature by a max. internal enclosure temperature of +35 °C



Comprehensive technical documentation such as

- operating instruction, technical data, approvals
- cut-out drawing, CAD | EPLAN | Zuken | WSCAD data

can be retrieved by entering this webcode in the search window on [www.pfannenberg.com](http://www.pfannenberg.com)

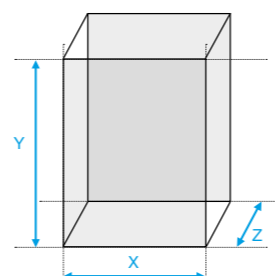

## MINI-RADIANT HEATERS 10–30 W

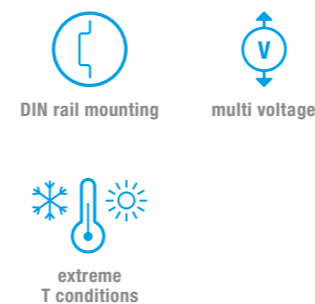

3 different performance ratings are available. The total heat necessary can be distributed according to the needs.

**Applications**  
For the avoidance of low temperatures or excessively high relative humidity.

**Electrical connection**  
via a 300 mm connecting cable.

**Snap fastening**  
for 35 mm DIN-rail is integrated.

**Suitable**  
for use in small housings or to heat isolated spots in sensitive areas.

**Long life**  
and robust construction without fan.



PRODUCT	PRH 010-M	PRH 020-M	PRH 030-M	
ARTICLE NO.	17000105317	17000205317	17000305317	Unit

DATA				
Heating performance (Ta = +20 °C)	10	20	30	W
Rated voltage ±10 %	AC 50   60 Hz			
	230			V
Functional range	110–250 V AC 50   60 Hz			
Max. starting current	1	1.1	1.2	A
Max. surface temperature	95	115	140	°C
Operating temperature	–40 ... +70			
Type of mounting	snap fastening for 35 mm profile bars according to EN 60715			
Type of connection	connecting cable (300 mm)			
Dimensions (X x Y x Z)	29.5 x 45 x 75			mm

ACCESSORIES	ARTICLE NUMBER	Page
Thermostat	17111000000	154
Hygostat	17207000000	156
Internal enclosure fan	18110000000	39

For additional models, options and voltages visit [www.pfannenberg.com](http://www.pfannenberg.com) or contact us directly.

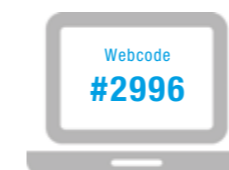

Comprehensive technical documentation such as

- operating instruction, technical data, approvals
- cut-out drawing, CAD | EPLAN | Zuken | WSCAD data

can be retrieved by entering this webcode in the search window on [www.pfannenberg.com](http://www.pfannenberg.com)

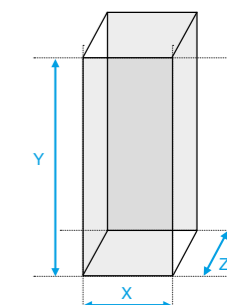

## FAN HEATERS 250–400 W



DIN rail mounting



extreme T conditions

**Heat distribution**  
The fan and the powerful heat output ensure quick and even distribution of heat.

**Long life**  
and robust construction with integrated fan which supports the natural convection.

**Electrical connection**  
via plug terminal connector.



**Applications**  
Predominantly used in larger control cabinets for the avoidance of low temperatures or high relative humidity.

**Mounting**  
Integrated snap fastening for 35 mm DIN-rail.

PRODUCT	FLH 250	FLH 400	
ARTICLE NO.	17025010007	17040010007	Unit
ARTICLE NO. with 2 <sup>nd</sup> protective grille	17025010107	17040010107	

DATA			
Heating performance (Ta = +20 °C)	250	400	W
Rated voltage ±10 %	AC 50   60 Hz		
	230		V
Functional range	207–258 V AC 50   60 Hz		
Max. starting current	1.1	1.8	A
Max. surface temperature	70	85	°C
Operating temperature	–40 ... +70		
Type of mounting	snap fastening for 35 mm profile bars according to EN 60715		
Type of connection	plug terminal connector		
Dimensions (X x Y x Z)	85 x 186.5 x 104	85 x 226.5 x 104	mm

ACCESSORIES	ARTICLE NUMBER	Page
Thermostat	17111000000	154
Hygostat	17207000000	156
Internal enclosure fan	18110000000	39

For additional models, options and voltages visit [www.pfannenberg.com](http://www.pfannenberg.com) or contact us directly.



Comprehensive technical documentation such as

- operating instruction, technical data, approvals
- cut-out drawing, CAD | EPLAN | Zuken | WSCAD data

can be retrieved by entering this webcode in the search window on [www.pfannenberg.com](http://www.pfannenberg.com)

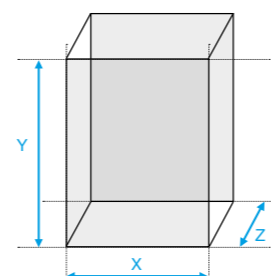

## FAN HEATER 250 W



shock resistancy



extreme T conditions

**Fan design**  
with ball bearing guarantees long service life.

**The compact design**  
make it ideal for use in enclosures with limited space.

**All tests**  
were performed according to European Norms; EN 60068-2-6 | 60068-2-27 | 60068-2-29 Railway applications | Rolling stock equipment | Shock and vibration tests.

**Electrical connection**  
via plug terminal connector.



**Applications**  
Predominantly used in larger control cabinets for the avoidance of low temperatures or high relative humidity.

**High volume flow**  
created by the powerful fan means a quick and even distribution of heat.

**Mounting**  
Integrated galvanised fixing support with 4 slot holes M6.

PRODUCT	FLH 250 SL	
ARTICLE NO.	17025110007	Unit

DATA		
Heating performance (Ta = +20 °C)	250	W
Rated voltage ±10 %	AC 50   60 Hz	
	230	
Functional range	207–258 V AC 50   60 Hz	
Max. starting current	2.4	A
Max. surface temperature	70	°C
Operating temperature	–40 ... +70	
Type of mounting	M6 screw fastening	
Type of connection	plug terminal connector	
Dimensions (X x Y x Z1 + Z2)	126 x 170.5 x 75 + 105	

ACCESSORIES	ARTICLE NUMBER	Page
Thermostat	17111000000	154
Hygostat	17207000000	156
Internal enclosure fan	18110000000	39

For additional models, options and voltages visit [www.pfannenberg.com](http://www.pfannenberg.com) or contact us directly.

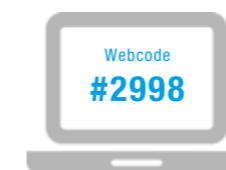

Comprehensive technical documentation such as

- operating instruction, technical data, approvals
- cut-out drawing, CAD | EPLAN | Zuken | WSCAD data

can be retrieved by entering this webcode in the search window on [www.pfannenberg.com](http://www.pfannenberg.com)

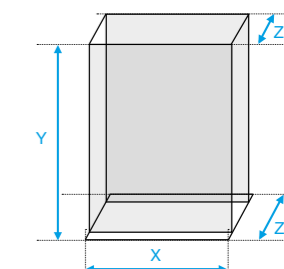

## FAN HEATERS WITH INTEGRATED THERMOSTAT 250–400 W



shock resistancy



extreme T conditions



integrated thermostat

### High volume flow

created by the powerful fan means a quick and even distribution of heat.

### Long life

Fan design with ball bearing guarantees long service life.

### Electrical connection

via 2-pole terminal strip.

### All tests

were performed according to European Norms; EN 60068-2-6 | 60068-2-27 | 60068-2-29  
Railway applications | Rolling stock equipment | Shock and vibration tests.



### Applications

Predominantly used in larger control cabinets for the avoidance of low temperatures or high relative humidity.

### Integrated thermostat

regulates the operation of the heater automatically. Therefore provides safe protection against condensate forming or energy waste.

### Specifically developed

for demanding environments, e.g. wind turbines and telecommunications sector.

PRODUCT	FLH-T 250	FLH-T 400	
ARTICLE NO.	17025310007	17040310007	Unit

DATA			
Heating performance (Ta = +20 °C)	250	400	W
Rated voltage ±10 %	AC 50   60 Hz		
	230		V
Functional range	207–253 V AC 50   60 Hz		
Max. starting current	0.7	2.6	A
Temperature setting range	–20 ... +40		°C
Operating temperature	–40 ... +70		
Type of mounting	4x M5 screws (not included)		
Type of connection	2-pole terminal strip		
Dimensions (X x Y x Z)	150 x 100 x 164		mm

ACCESSORIES	ARTICLE NUMBER	Page
Hygostat	17207000000	156
Internal enclosure fan	18110000000	39

For additional models, options and voltages visit [www.pfannenberg.com](http://www.pfannenberg.com) or contact us directly.



Comprehensive technical documentation such as

- operating instruction, technical data, approvals
- cut-out drawing, CAD | EPLAN | Zuken | WSCAD data

can be retrieved by entering this webcode in the search window on [www.pfannenberg.com](http://www.pfannenberg.com)

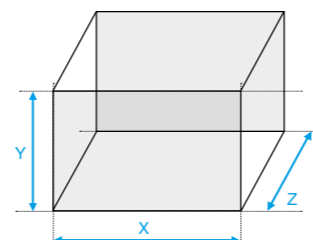

## FAN HEATERS WITH INTEGRATED THERMOSTAT 600–1000 W



shock resistancy



extreme T conditions



integrated thermostat

### High volume flow

created by the powerful fan means a quick and even distribution of heat.

### Long life

Fan design with ball bearing guarantees long service life.

### Electrical connection

via 2-pole terminal strip.

### All tests

were performed according to European Norms; EN 60068-2-6 | 60068-2-27 | 60068-2-29  
Railway applications | Rolling stock equipment | Shock and vibration tests.



### Applications

Predominantly used in larger control cabinets for the avoidance of low temperatures or high relative humidity.

### Integrated thermostat

regulates the operation of the heater automatically. Therefore provides safe protection against condensate forming or energy waste.

### Specifically developed

for demanding environments, e.g. wind turbines and telecommunications sector.

PRODUCT	FLH-T 600	FLH-T 800	FLH-T 1000	
ARTICLE NO.	17060310007	17080310007	17099310007	Unit

DATA				
Heating performance (Ta = +20 °C)	600	800	1000	W
Rated voltage ±10 %	AC 50   60 Hz			
	230			V
Functional range	207–253 V AC 50   60 Hz			
Max. starting current	3.4	4.3	5.2	A
Temperature setting range	–20 ... +40			°C
Operating temperature	–40 ... +70			
Type of mounting	4x M5 screws (not included)			
Type of connection	2-pole terminal strip			
Dimensions (X x Y x Z)	150 x 100 x 164			mm

ACCESSORIES	ARTICLE NUMBER	Page
Hygostat	17207000000	156
Internal enclosure fan	18110000000	39

For additional models, options and voltages visit [www.pfannenberg.com](http://www.pfannenberg.com) or contact us directly.

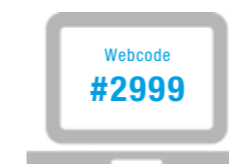

Comprehensive technical documentation such as

- operating instruction, technical data, approvals
- cut-out drawing, CAD | EPLAN | Zuken | WSCAD data

can be retrieved by entering this webcode in the search window on [www.pfannenberg.com](http://www.pfannenberg.com)

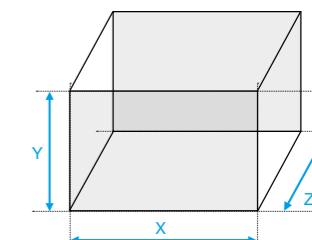

## COMPACT FAN HEATERS 200–1200 W



DIN rail mounting



extreme T conditions

**Variable mounting options** directly on the wall with screws or snap fastener on DIN rail.

**Safe protection** against condensate forming in the cabinet by means of fast heating due to PTC technology.

**Wide range** of heating capacities from 200 to 1,200 W in one slim compact housing.

**Electrical connection** via plug terminal connector.



**Finger guard** at air inlet and outlet as well as a low surface temperature ensure secure handling.

**Predominantly used** in larger control cabinets for the avoidance of low temperatures or high relative humidity.

**Fixed-value thermostat** for the automatic regulation of the cabinet's minimum temperature can be easily integrated.

PRODUCT	PFH 200	PFH 300	PFH 400	PFH 500	
ARTICLE NO.	17020610030	17030610030	17040610030	17050610030	Unit

DATA					
Heating performance (Ta = +10 °C)	200	300	400	500	W
Max. starting current	9	12	15	20	A
Max. pre fuse T	6		10		
Max. surface temperature	55				°C

PRODUCT	PFH 650	PFH 800	PFH 1000	PFH 1200	
ARTICLE NO.	17065610030	17080610030	17099610030	17099910030	Unit

DATA					
Heating performance (Ta = +10 °C)	650	800	1000	1200	W
Max. starting current	25	31	25	31	A
Max. pre fuse T	10				
Max. surface temperature	70				°C
Operating temperature	-40 ... +70				
Rated voltage ±10 %	AC 50   60 Hz				
	230				V
Functional range	207–253 V AC 50   60 Hz				
Type of mounting	snap fastening for 35 mm profile bars according to EN 60715   4x M5 screws (not included)				
Type of connection	plug terminal connector				
Dimensions (X x Y x Z)	88 x 142 x 126				mm

ACCESSORIES	ARTICLE NUMBER	Page
Hygostat	17207000000	156
Internal enclosure fan	18110000000	39
Plug-in fixed-point thermostat	5 °C	18413000000
	15 °C	18413000001
	25 °C	18413000002

For additional models, options and voltages visit [www.pfannenberg.com](http://www.pfannenberg.com) or contact us directly.



Comprehensive technical documentation such as

- operating instruction, technical data, approvals
- cut-out drawing, CAD | EPLAN | Zuken | WSCAD data

can be retrieved by entering this webcode in the search window on [www.pfannenberg.com](http://www.pfannenberg.com)

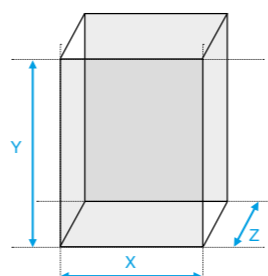

## COMPACT FAN HEATERS WITH INTEGRATED THERMOSTAT 200–1200 W



DIN rail mounting



extreme T conditions



integrated thermostat

**Variable mounting options** directly on the wall with screws or snap fastener on DIN rail.

**Safe protection** against condensate forming in the cabinet by means of fast heating due to PTC technology.

**Wide range** of heating capacities from 200 to 1,200 W in one slim compact housing.

**Electrical connection** via plug terminal connector.



**Finger guard** at air inlet and outlet as well as a low surface temperature ensure secure handling.

**Predominantly used** in larger control cabinets for the avoidance of excessively low temperatures or excessively high relative humidity.

**Integrated adjustable thermostat** for the automatic regulation of the cabinet's minimum temperature.

PRODUCT	PFH-T 200	PFH-T 300	PFH-T 400	PFH-T 500	
ARTICLE NO.	17020710034	17030710034	17040710034	17050710034	Unit

DATA					
Heating performance (Ta = +10 °C)	200	300	400	500	W
Max. starting current	9	12	15	20	A
Max. pre fuse T	6		10		
Max. surface temperature	55				°C

PRODUCT	PFH-T 650	PFH-T 800	PFH-T 1000	PFH-T 1200	
ARTICLE NO.	17065710034	17080710034	17099710034	17099810034	Unit

DATA					
Heating performance (Ta = +10 °C)	650	800	1000	1200	W
Max. starting current	25	31	25	31	A
Max. pre fuse T	10				
Max. surface temperature	70				°C
Operating temperature	-40 ... +70				
Rated voltage ±10 %	AC 50   60 Hz				
	230				V
Functional range	207–258 V AC 50   60 Hz				
Type of mounting	snap fastening for 35 mm profile bars according to EN 60715   4x M5 screws (not included)				
Type of connection	plug terminal connector				
Dimensions (X x Y x Z)	88 x 142 x 139				mm

ACCESSORIES	ARTICLE NUMBER	Page
Hygostat	17207000000	156
Internal enclosure fan	18110000000	39

For additional models, options and voltages visit [www.pfannenberg.com](http://www.pfannenberg.com) or contact us directly.

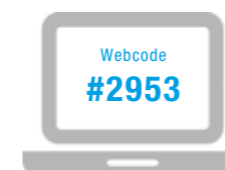

Comprehensive technical documentation such as

- operating instruction, technical data, approvals
- cut-out drawing, CAD | EPLAN | Zuken | WSCAD data

can be retrieved by entering this webcode in the search window on [www.pfannenberg.com](http://www.pfannenberg.com)

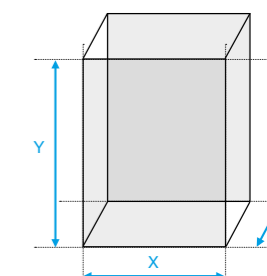

## THERMOSTATS



switch point tolerance (FLZ 510)



switch point tolerance (FLZ 510)



changeover spring contact (FLZ 510)



normally closed spring contact (FLZ 520)



normally open spring contact (FLZ 530)

The FLZ series of thermostats consists of three versions. They are available with normally closed | normally open and changeover contacts.

In combination with filterfans, they provide for additional savings on energy, materials and time – for a better environmental balance.

Electrical connection using screw terminals, and fast snap fastening on DIN rail.

In combination with control cabinet heaters they regulate the temperature inside the control cabinet.

Using thermostats you can achieve greater reliability in the production process, reduced energy consumption due to need-based use and an improvement in the efficiency of the controlled heaters and filterfans.



PRODUCT		FLZ 510		FLZ 520	FLZ 530	
ARTICLE NO.	-20 ... +40 °C	17103000003	17105000003	17111000003	17121000003	Unit
ARTICLE NO.	0 ... +60 °C	17103000000	17105000000	17111000000	17121000000	
ARTICLE NO.	+20 ... +80 °C	17103000004	17105000004	17111000004	17121000004	

DATA						
Type of contact	changeover with spring contact		N.C. with spring contact	N.O. with spring contact		
Switching temperature difference	1	3	< 7			K
Switching point tolerance	±3		±4			
Max. switching power value in brackets: inductive load at cos φ = 0.6	N.C.	100–250 V AC / 10 (2)		240 V AC / 10 (2)		A
	N.O.	100–250 V AC / 5 (2)		120 V AC / 15 (2)		W
	DC	max. 30		max. 30		°C
Operating temperature	-40 ... +80		-20 ... +80			
Suitable for the operation of	fan and heater		heater	fan		
Type of mounting	snap fastening for 35 mm profile bars according to EN 60715					
Type of connection	screw terminal for cable cross-section 0.5 to 2.5 mm <sup>2</sup>					
Dimensions (X x Y x Z)	37 x 59.5 x 47.5		40 x 72 x 36			mm
Colour	RAL 7035					

ACCESSORIES	ARTICLE NUMBER	Page
Hygostat	17207000000	156
Internal enclosure fan	18110000000	39

For additional models, options and voltages visit [www.pfannenberg.com](http://www.pfannenberg.com) or contact us directly.



FLZ 520  
FLZ 530



Comprehensive technical documentation such as

- operating instruction, technical data, approvals
- cut-out drawing, CAD | EPLAN | Zuken | WSCAD data

can be retrieved by entering this webcode in the search window on [www.pfannenberg.com](http://www.pfannenberg.com)

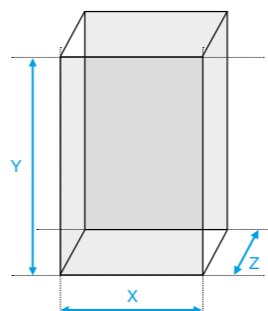

## TWIN THERMOSTATS



N.C./N.O. spring contact (FLZ 541)



N.C./N.C. spring contact (FLZ 542)



N.O./N.O. spring contact (FLZ 543)

The FLZ series twin thermostats integrate three independently switchable thermostats. They are available with normally closed/normally open, normally closed/normally closed and normally open/normally open contacts.

Using thermostats you can achieve greater reliability in the production process, reduced energy consumption due to need-based use and an improvement in the efficiency of the controlled heaters and filterfans.

In combination with filterfans, they provide for additional savings on energy, materials and time and – for a better environmental balance.

In combination with control cabinet heaters they regulate the temperature inside the control cabinet.

Electrical connection using screw terminals, and fast snap fastening on DIN rail.



PRODUCT		FLZ 541	FLZ 542	FLZ 543	
ARTICLE NO.	0 ... +60 °C	17141000000	17142000000	17143000000	Unit

DATA					
Type of contact	N.C./N.O. with spring contact		N.C./N.C. with spring contact	N.O./N.O. with spring contact	
Switching temperature difference	< 7				K
Switching point tolerance	±4				
Max. switching power value in brackets: inductive load at cos φ = 0.6	N.C.	240 V AC / 10 (2)			A
	N.O.	120 V AC / 15 (2)			W
	DC	max. 30			°C
Setting range	0 ... +60				
Operating temperature	-20 ... +80				
Suitable for the operation of	fan and heater		heater	fan	
Type of mounting	snap fastening for 35 mm profile bars according to EN 60715				
Type of connection	screw terminal for cable cross-section 0.5 to 2.5 mm <sup>2</sup>				
Dimensions (X x Y x Z)	59 x 80.5 x 38				mm
Colour	RAL 7035				

ACCESSORIES	ARTICLE NUMBER	Page
Hygostat	17207000000	156
Internal enclosure fan	18110000000	39

For additional models, options and voltages visit [www.pfannenberg.com](http://www.pfannenberg.com) or contact us directly.



Comprehensive technical documentation such as

- operating instruction, technical data, approvals
- cut-out drawing, CAD | EPLAN | Zuken | WSCAD data

can be retrieved by entering this webcode in the search window on [www.pfannenberg.com](http://www.pfannenberg.com)

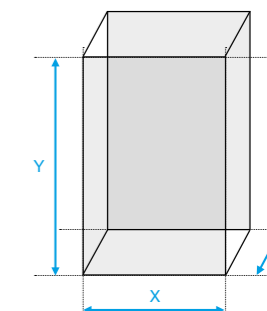

## HYGROSTATS



changeover spring contact



240V 8A max load (FLZ 610)

**Hygrostats** control cabinet heaters or filterfans when a preset relative humidity is exceeded.

**The relative humidity** is kept above the dew point and the condensation of water onto electrical components and the corrosion of unprotected sheet metal is prevented.

**In combination** with filterfans, they provide for additional savings on energy, materials and time and, hence, for a better environmental balance.

**Electrical connection** using screw terminals, and fast snap fastening on DIN rail.



**In combination** with control cabinet heaters, they serve for temperature control inside the control cabinet.

**Using hygrostats** you can achieve greater reliability in the production process, reduced energy consumption due to need-based use and an improvement in the efficiency of the controlled heaters and filterfans.

**The electronic combination device FLZ 610** unites thermostat and hygrostat in one housing and, at the same time, monitors the relative humidity and the temperature independently of each other.

PRODUCT	FLZ 600	FLZ 610	
ARTICLE NO.	17207000000	17218100000	Unit

DATA			
Device implementation	mechanical hygrostat		electronic hygrostat-thermostat combination device
Type of contact	changeover with spring contact		changeover/relay
Switching difference	approx. 5 %		approx. 2 K ±1 K / approx. 4 % R.H. ±1 %
Contact resistance	-		< 10
Max. switching power value in brackets: inductive load at cos φ = 0.6	N.C.	24–250 V AC / 5 (0.2) A – min. 100 mA	240 V AC, 8 (3) A or 120 V AC, 8 (3) A
	N.O.	24–250 V AC / 5 (0.2) A – min. 100 mA	24 V DC, 4 A
	DC	50 V, 1 A   75 V, 0.5 A   min. 100 mA	-
Setting range	40–90 % R.H.		0 ... +60
Operating temperature	0 ... +60		-20 ... +60
Suitable for the operation of	fan and heater		
Type of mounting	snap fastening for 35 mm profile bars according to EN 60715		
Type of connection	screw terminal for cable cross-section 0.5 to 2.5 mm <sup>2</sup>		
Dimensions (X x Y x Z)	37 x 60 x 55	59 x 80.5 x 38	
Colour	RAL 7035		

ACCESSORIES	ARTICLE NUMBER	Page
Thermostat	17207000000	154
Internal enclosure fan	18110000000	39

For additional models, options and voltages visit [www.pfannenber.com](http://www.pfannenber.com) or contact us directly.



Comprehensive technical documentation such as

- operating instruction, technical data, approvals
- cut-out drawing, CAD | EPLAN | Zuken | WSCAD data

can be retrieved by entering this webcode in the search window on [www.pfannenber.com](http://www.pfannenber.com)

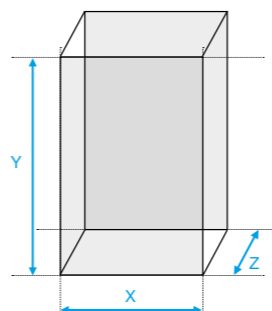

## STANDARD LAMP SYSTEMS – LED

Slim, maintenance free LED switch cabinet lamp. Simple connection with connecting adapter. On/off switch integrated. Including mounting clips and screws, and including magnet self-adhesive mounting film.



PRODUCT	PLS 008 MINI LED	PLS 013 MINI LED	
ARTICLE NO.	17308210020	17313210020	Unit
DATA			
Rated voltage ±10 %	AC 50   60 Hz		
	230		V
Current consumption	0.020	0.033	A
Light source	LED		
Light intensity	324	612	Lm
Type of connection	mains cable (1.8 m) with plug included		
Dimensions (L x H x D)	300 x 28 x 23.9	530 x 28 x 23.9	mm

## SOCKETS



PRODUCT	PPS D	PPS F	PPS USA	
ARTICLE NO.	17401000000	17402000000	17403000000	Unit

DATA			
Rated voltage ±10 %	AC 250		AC 125
Nominal current	10 A DC / 16 A AC		15 A AC
Mounting	snap fastening for 35 mm profile bars according to EN 60715		
Insulation stripping length	single wire: 0.2–4 mm <sup>2</sup> / fine wire: 0.2–2.5 mm <sup>2</sup> / AWG 24–AWG 12		
Standards/approvals	IEC 83, DIN 49440-1		UL   NEMA 5-15

## PRESSURE COMPENSATION DEVICE



## MOUNTING SUPPORT



PRODUCT	PPC	PRODUCT	PDR	
ARTICLE NO.	5 PIECES 17410050000	ARTICLE NO.	17411000000	Unit

DATA		DATA	
Thread	M12 x 1.5–10 mm	Fastening	self-adhesive
Material	polyamide 6, O ring: perbunan	Material	sheet steel, galvanised
Colour	RAL 7035	Dimensions (HxWxD)	35 x 70 x 7
Degrees of protection	IP 66   IP 68   IP 69K	Load capacity after 24hrs waiting period	500
			g

# Performance curves – Filterfans 4.0

## COOLING CAPACITY

## STATIC PRESSURE

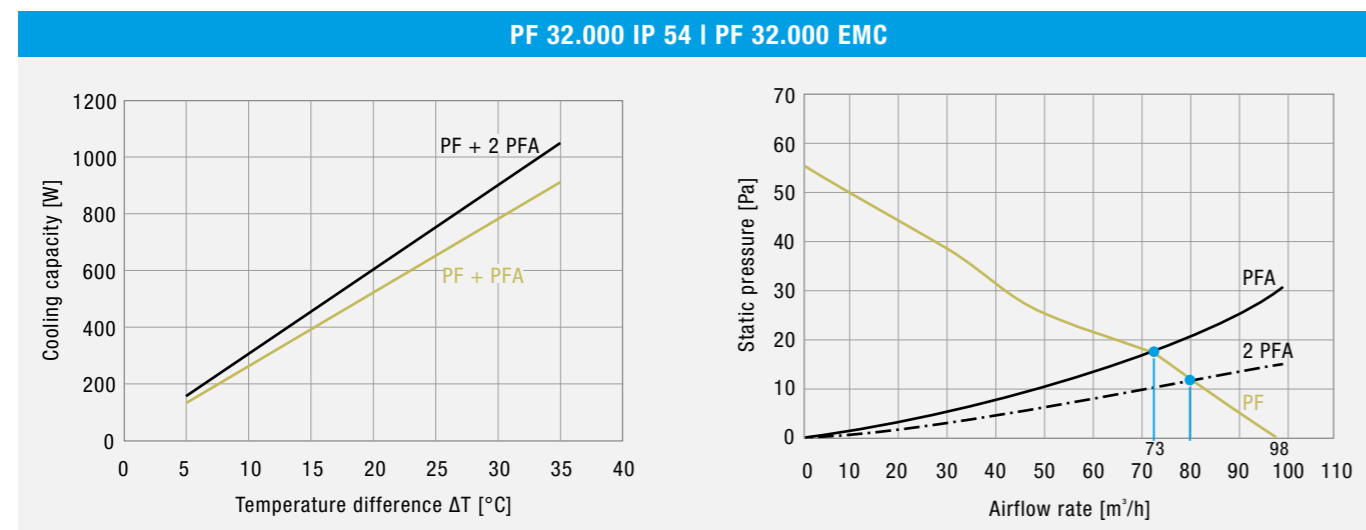
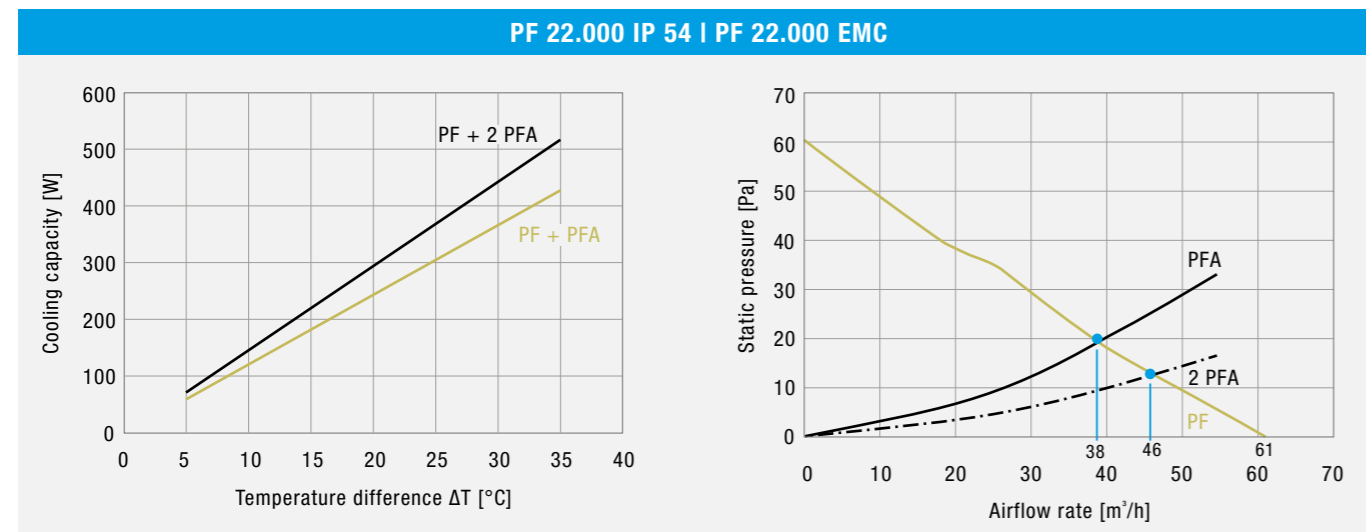
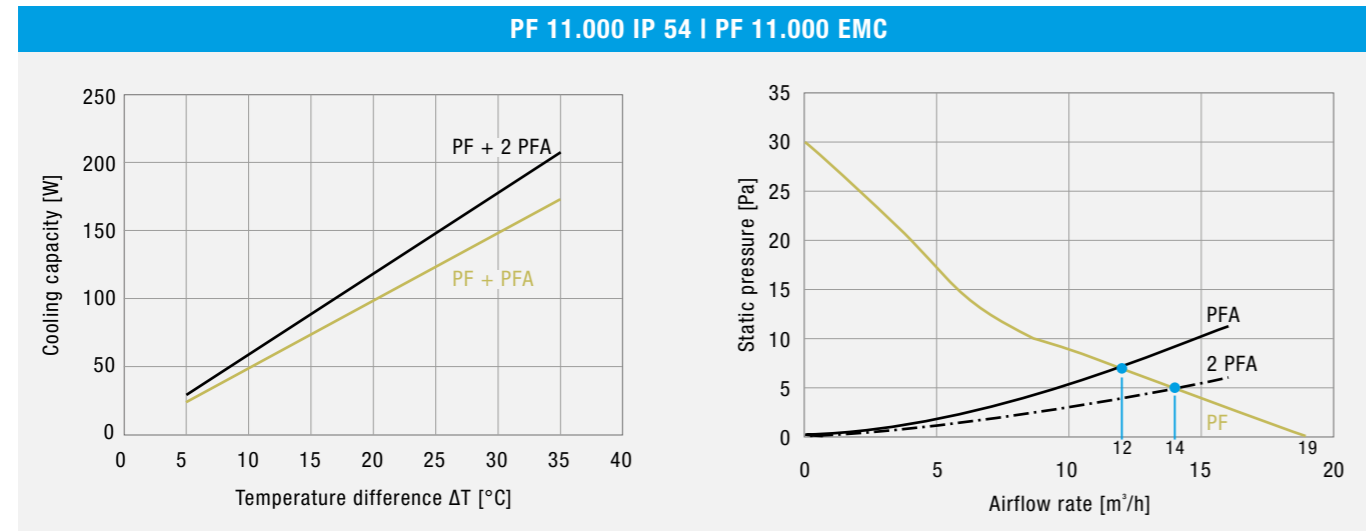

## COOLING CAPACITY

## STATIC PRESSURE

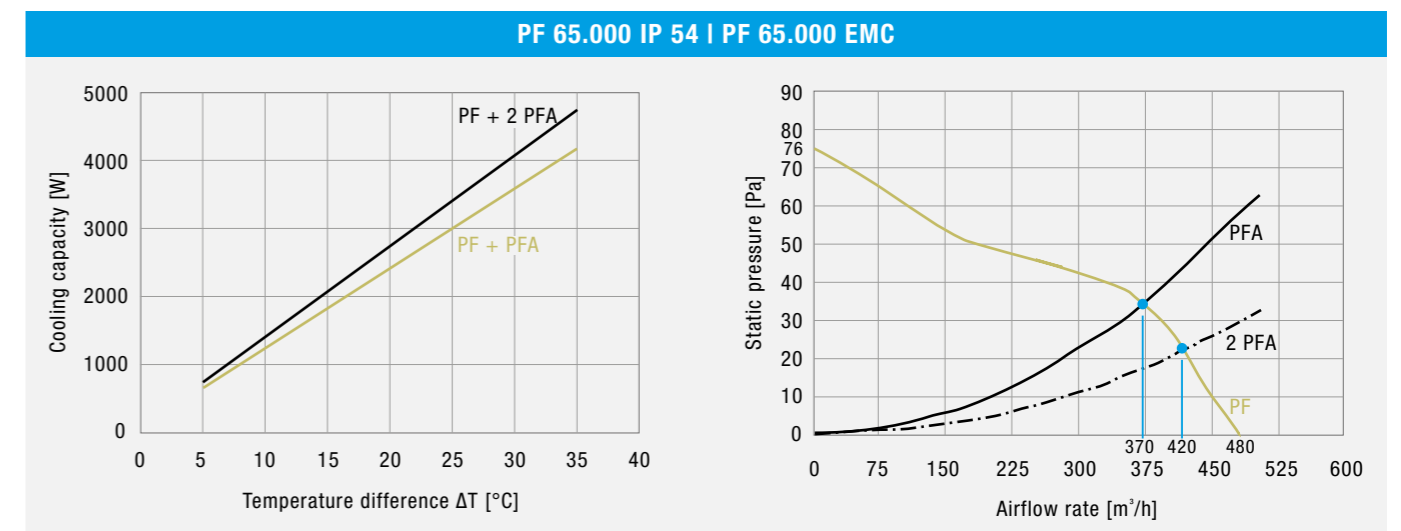
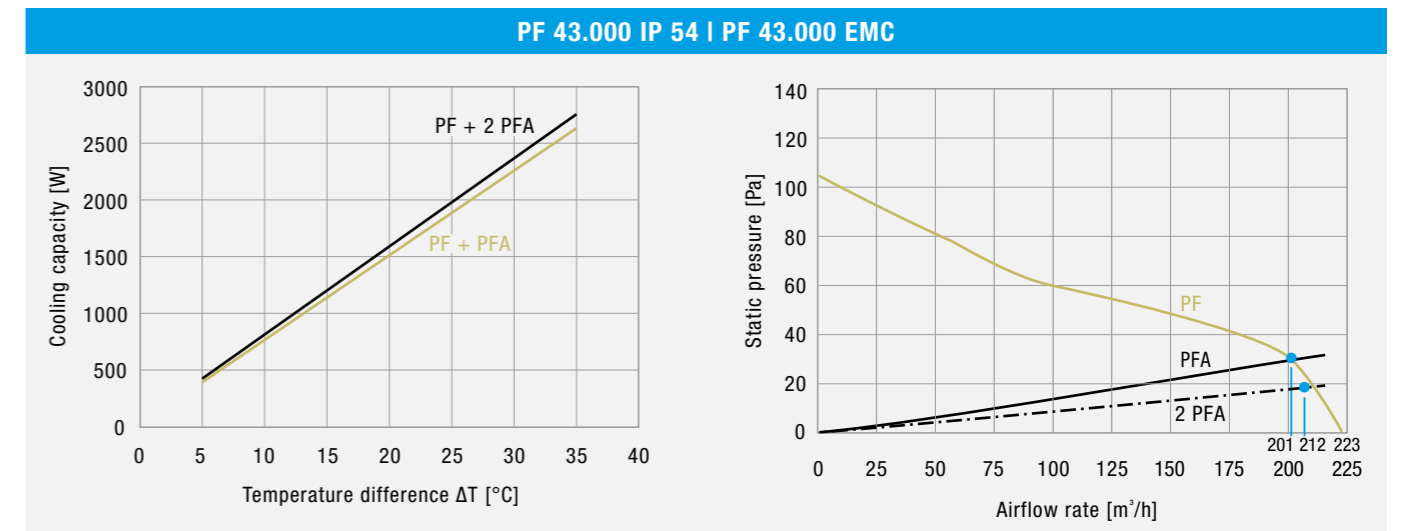
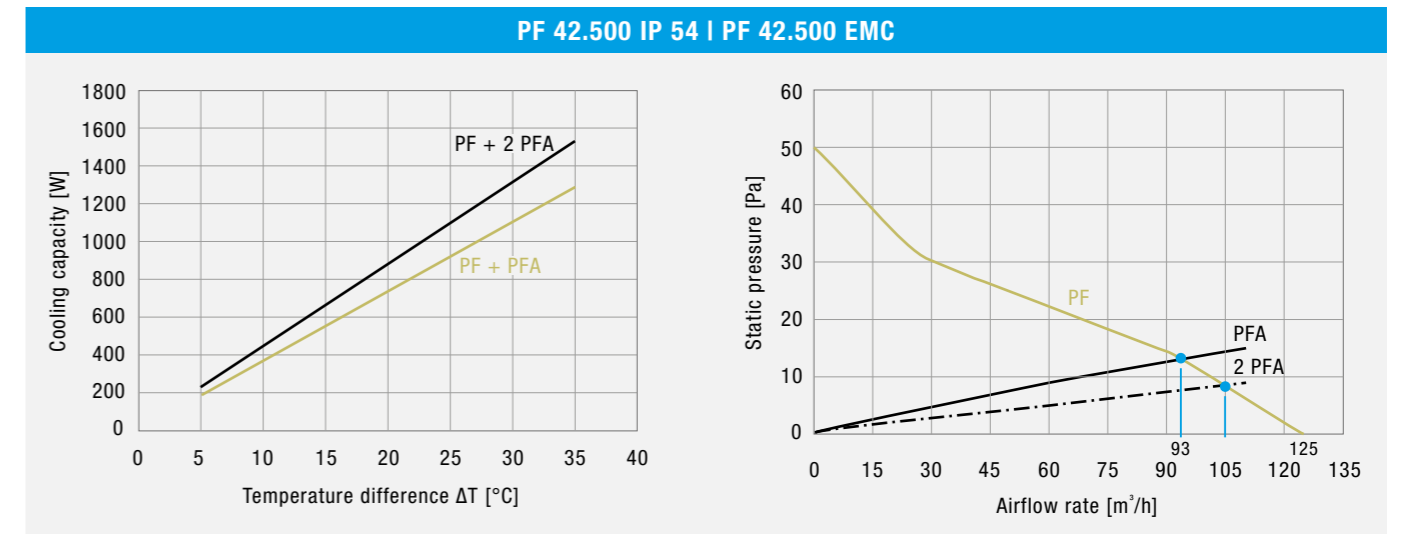

## COOLING CAPACITY

## STATIC PRESSURE

PF 66.000 IP 54 | PF 66.000 EMC

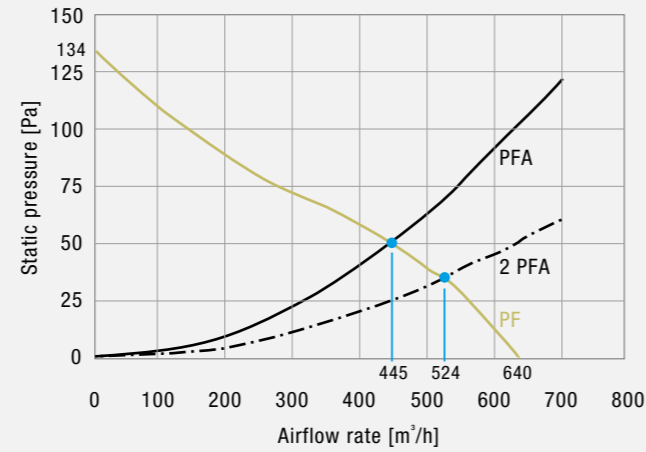
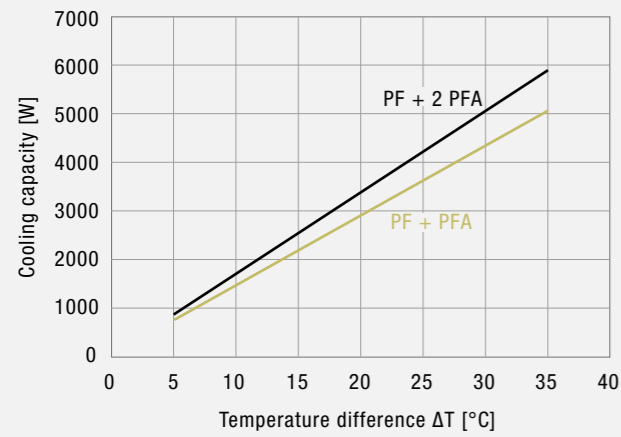

## COOLING CAPACITY

## STATIC PRESSURE

PF 32.000 IP 55

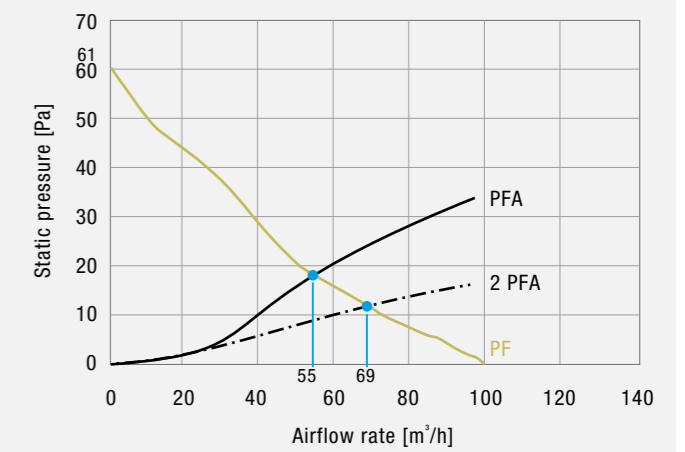
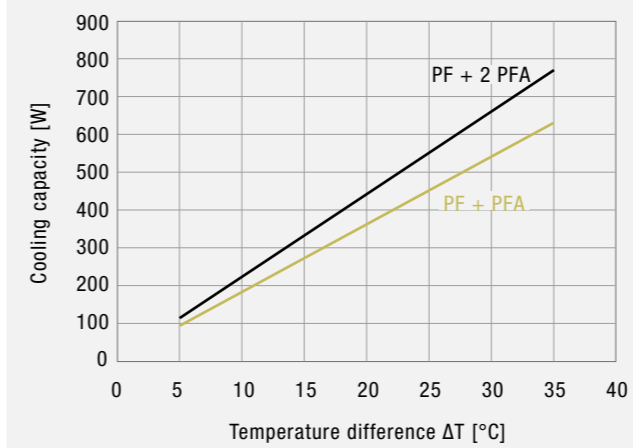

PF 67.000 IP 54 | PF 67.000 EMC

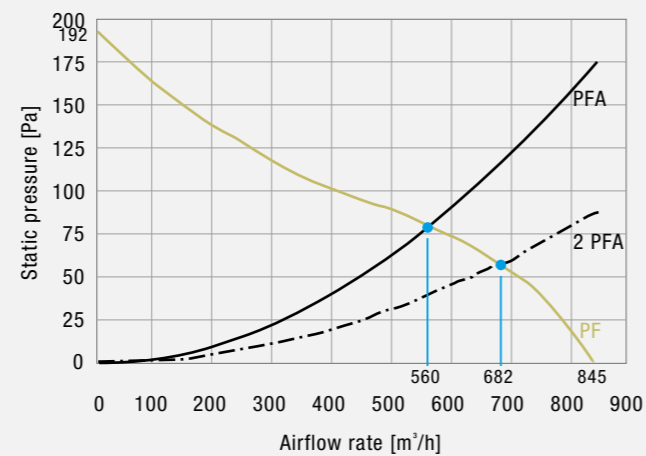
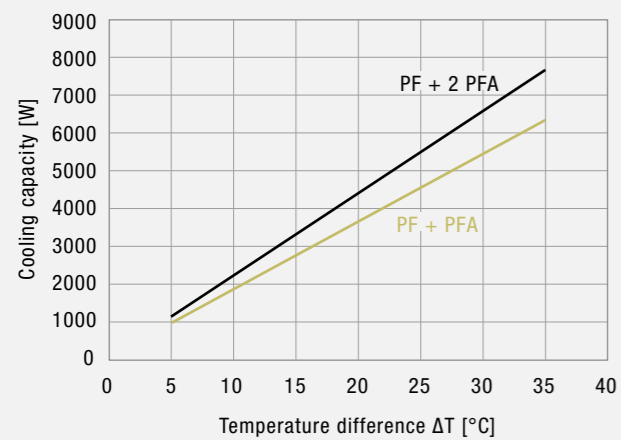

PF 42.500 IP 55

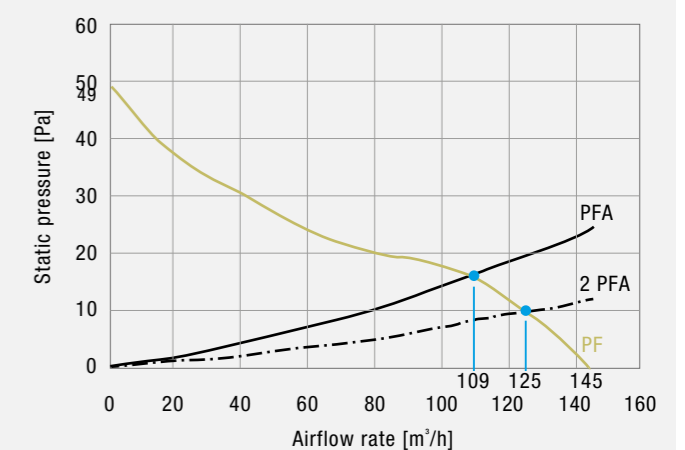
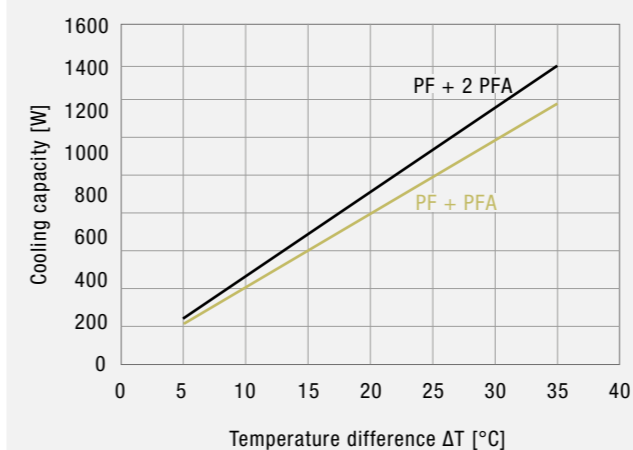

PF 22.000 IP 55

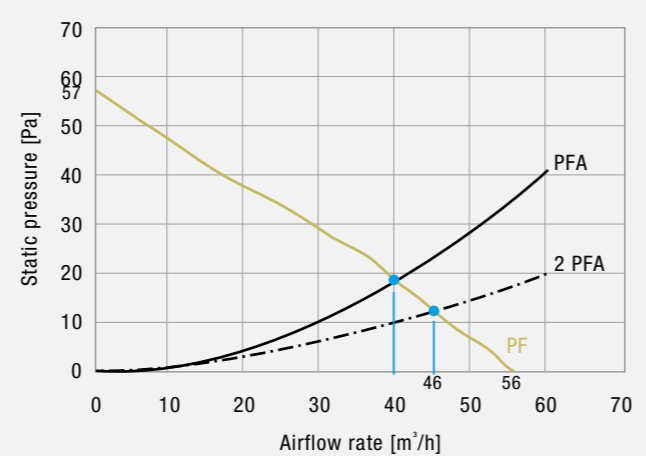
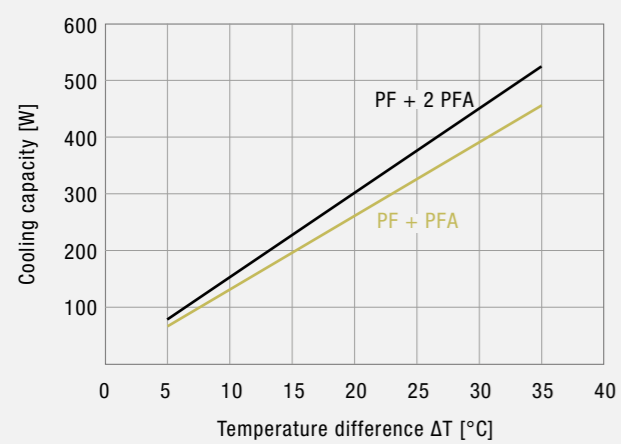

PF 43.000 IP 55

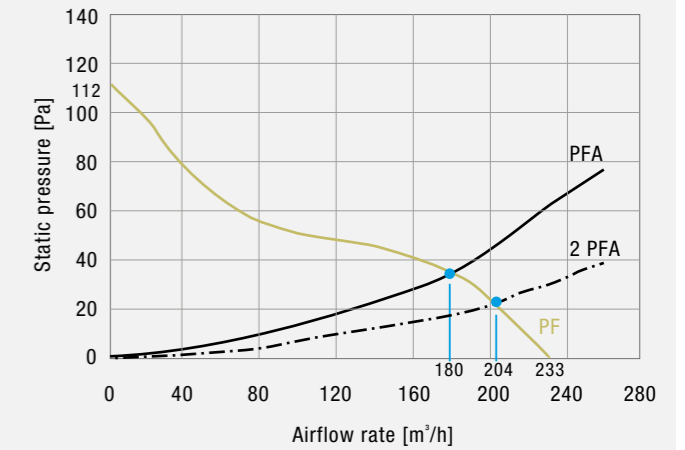
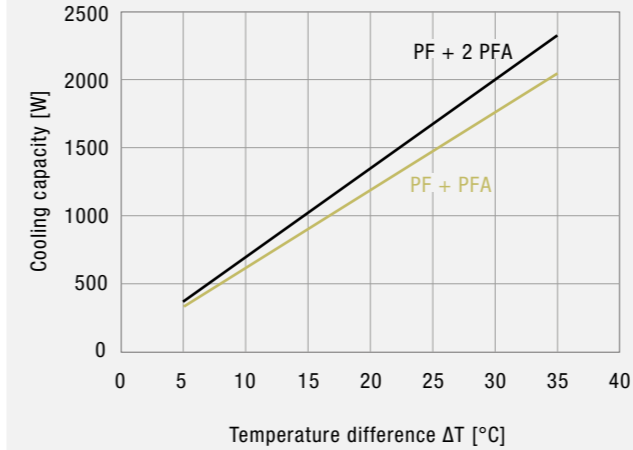

## COOLING CAPACITY

## STATIC PRESSURE

PF 65.000 IP 55

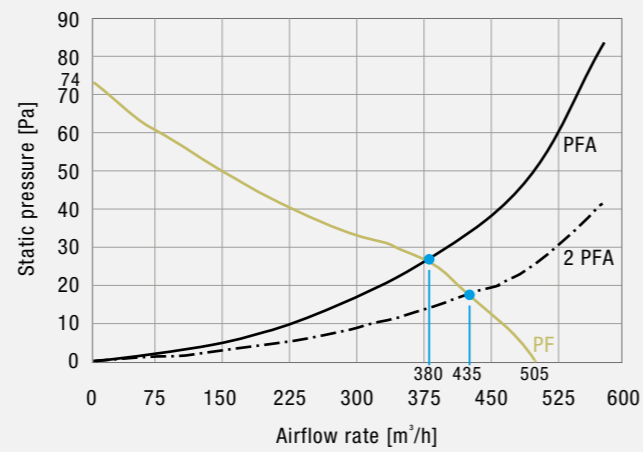
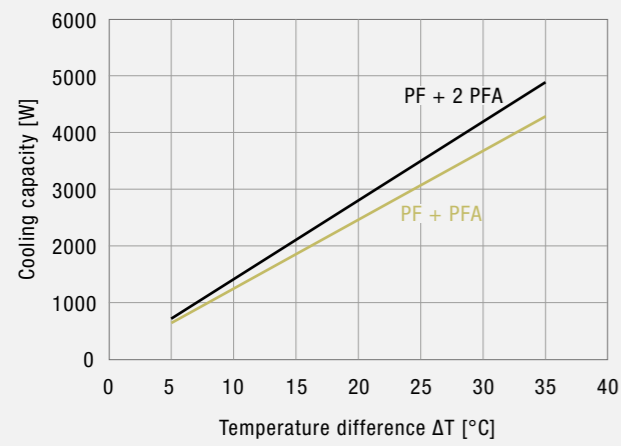

## COOLING CAPACITY

## STATIC PRESSURE

PTF 60.500 IP 54

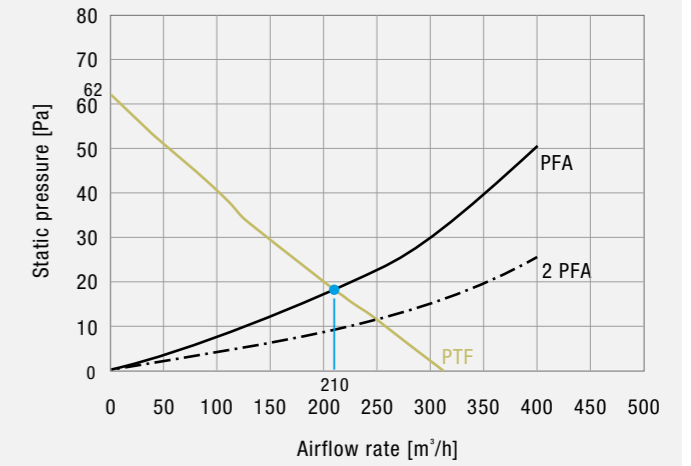
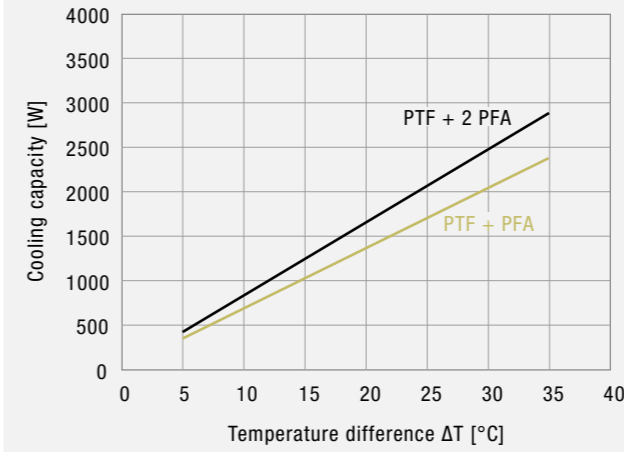

PF 66.000 IP 55

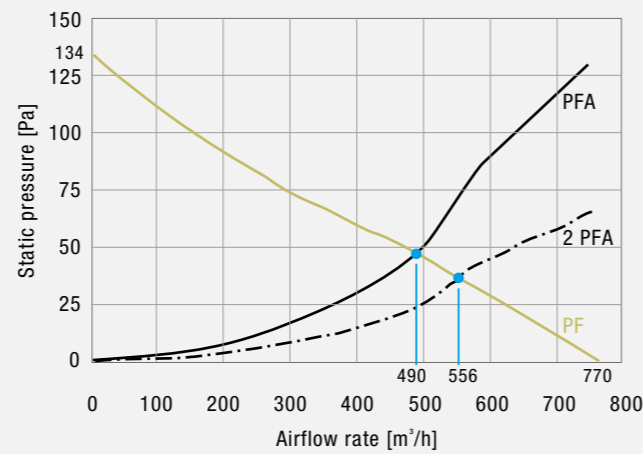
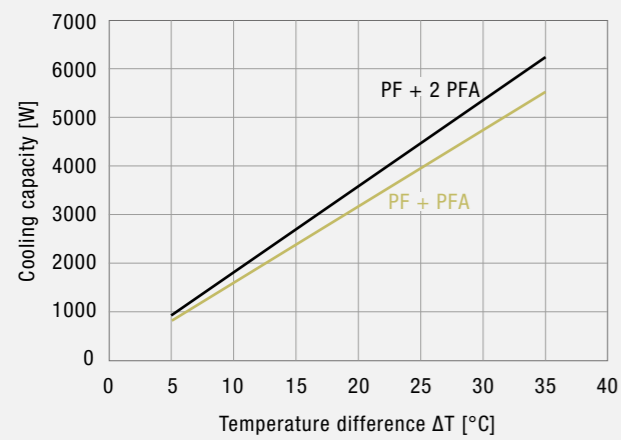

PTF 60.700 IP 54

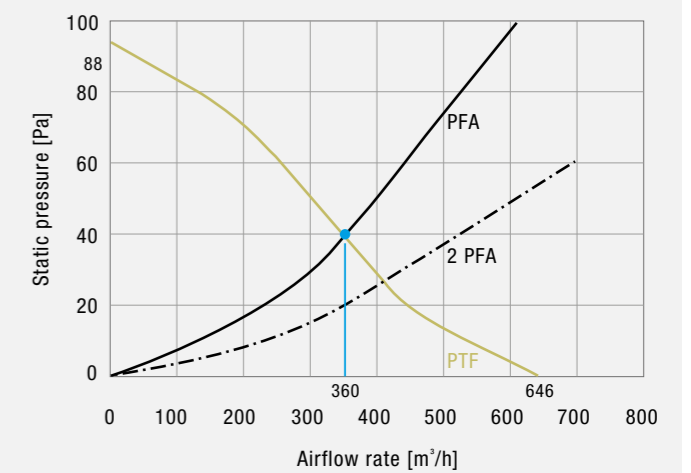
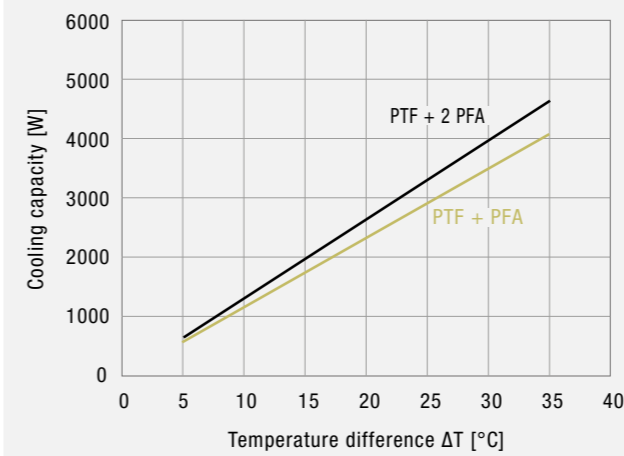

PF 67.000 IP 55

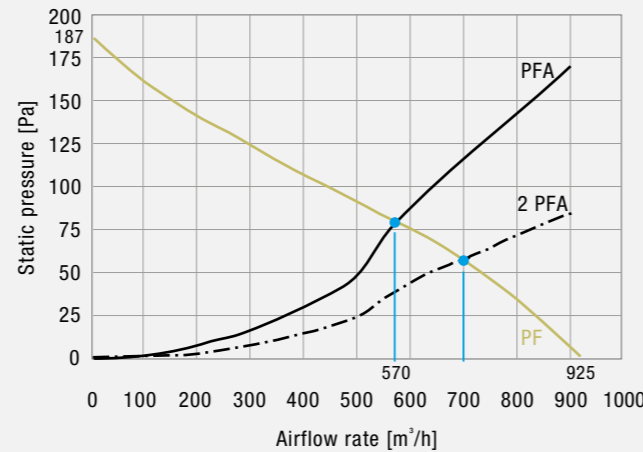
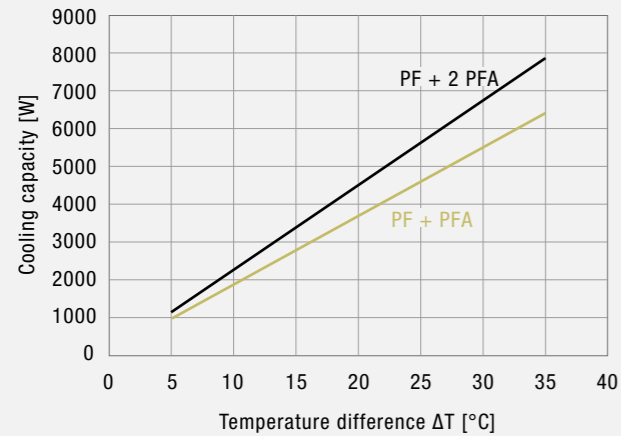

PTF 61.000 IP 54

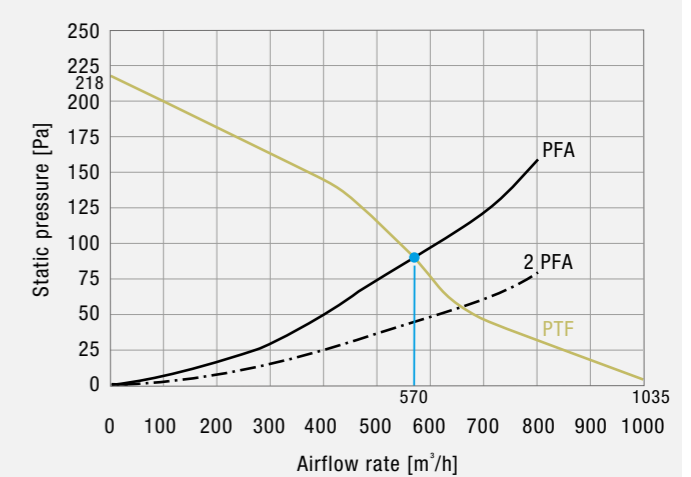
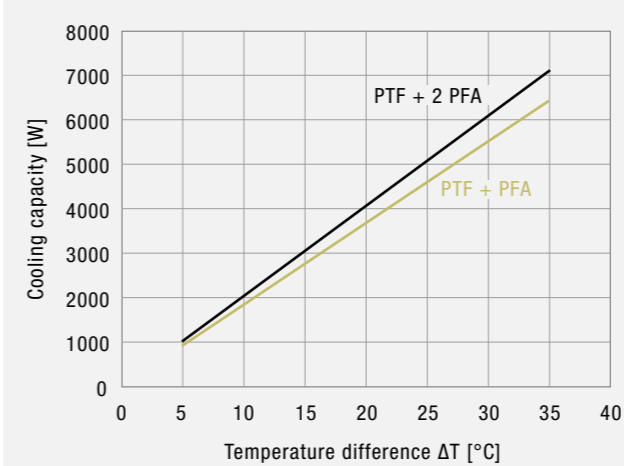

## COOLING CAPACITY

## STATIC PRESSURE

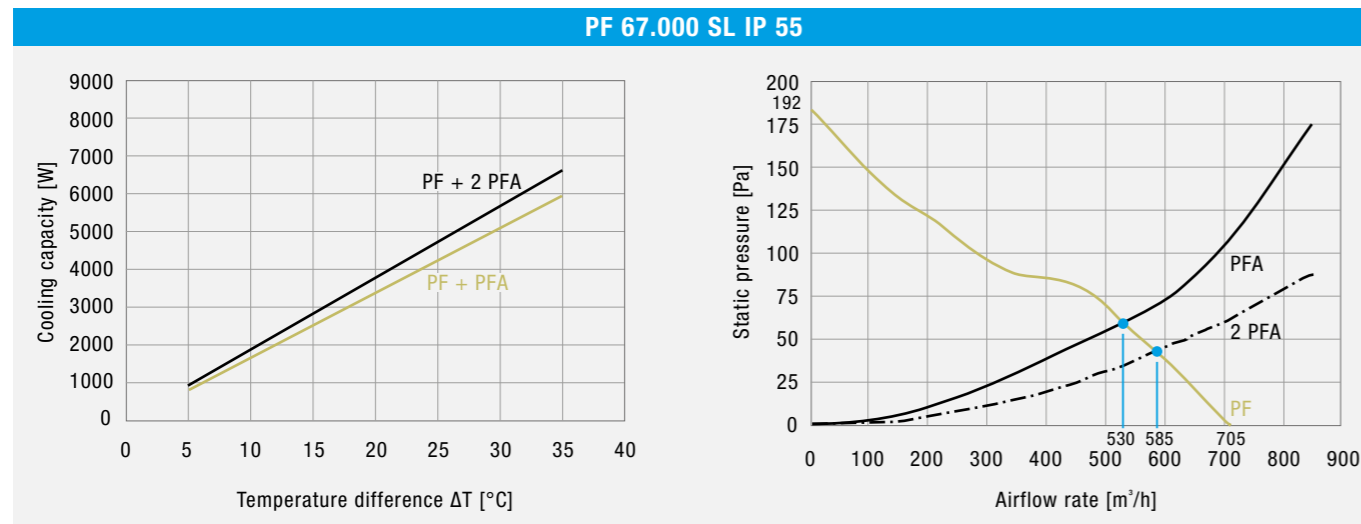
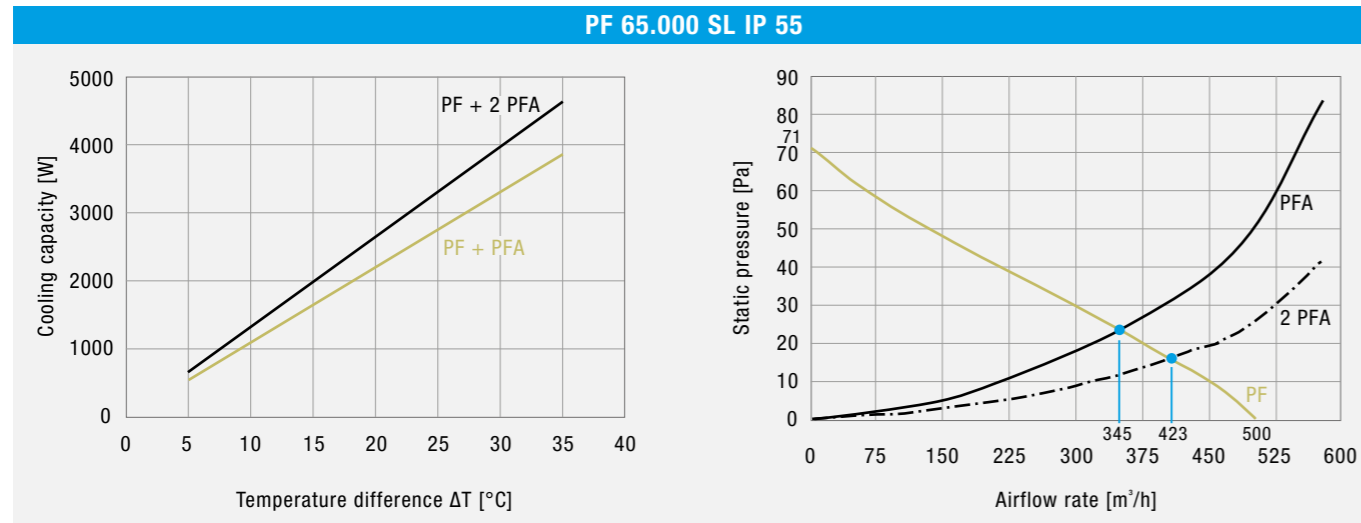

## Performance curves – Air/Air Heat Exchangers

## COOLING CAPACITY

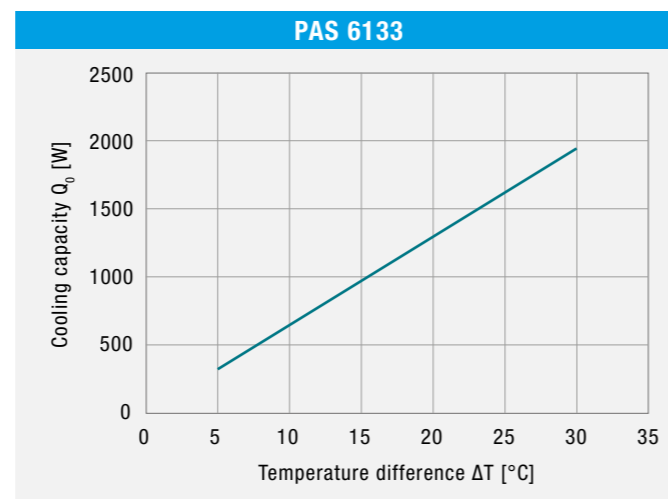
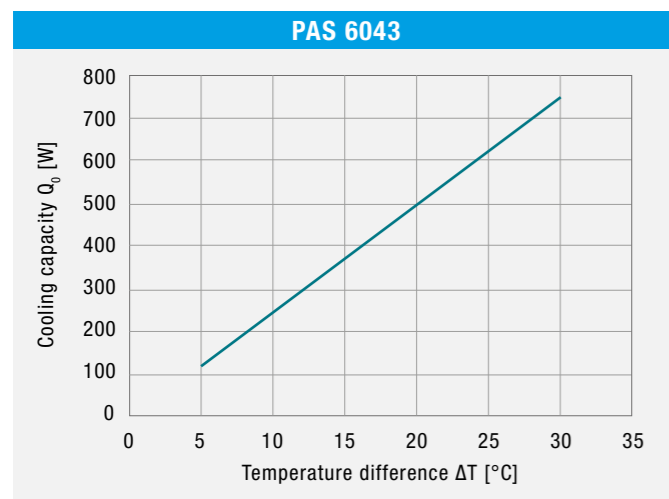

## COOLING CAPACITY

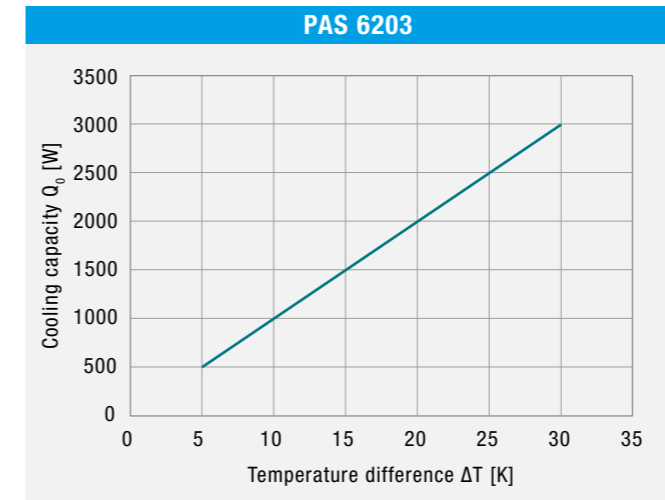

## Performance curves – Cooling Units

## COOLING CAPACITY

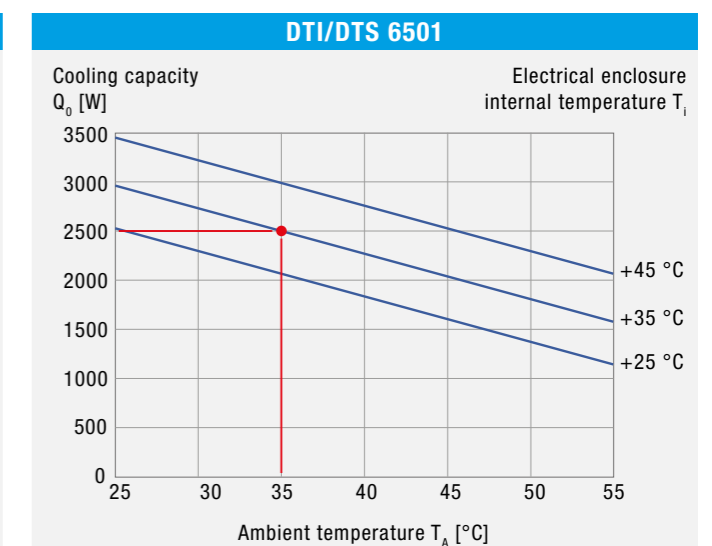
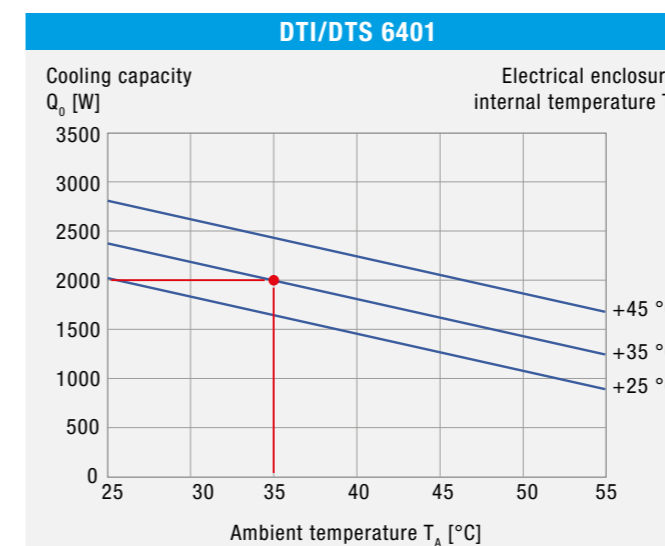
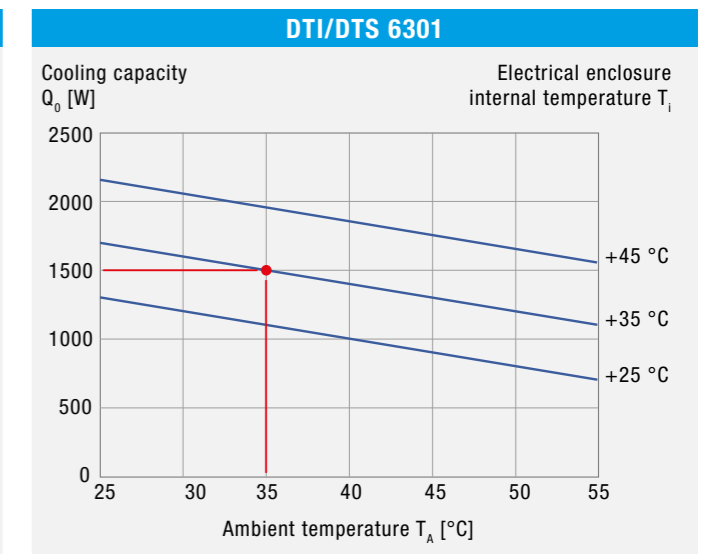
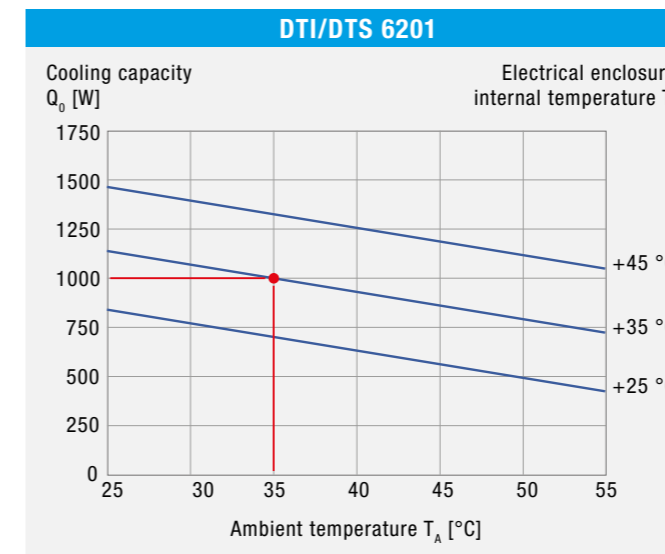

# COOLING CAPACITY

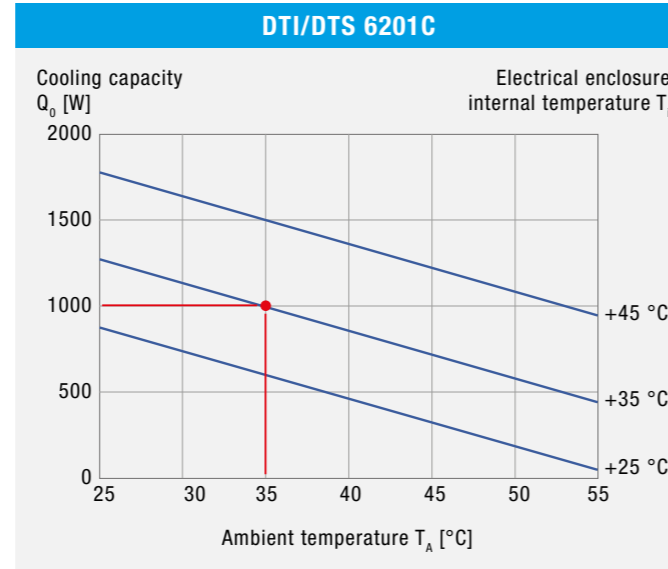
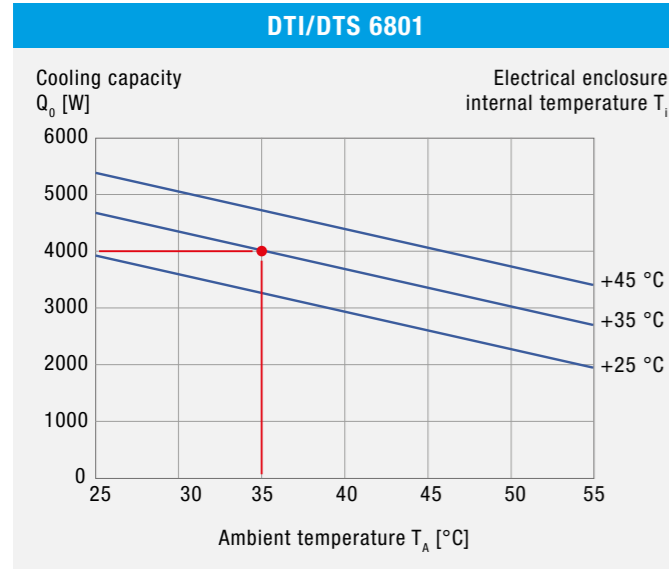

# COOLING CAPACITY

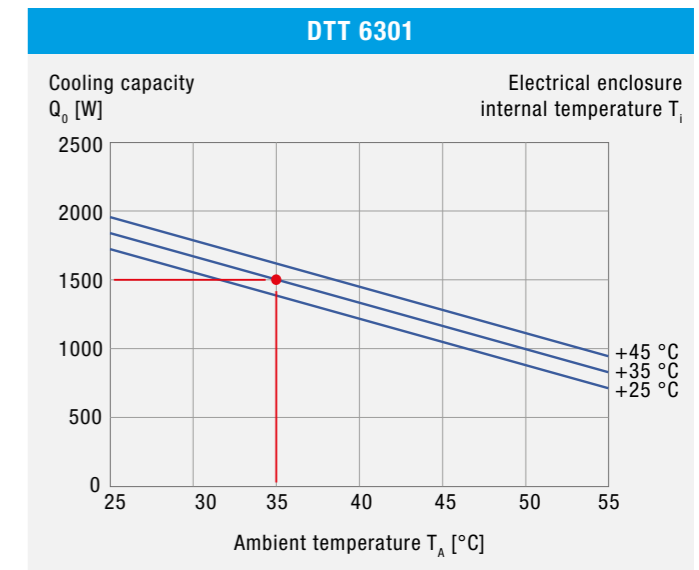
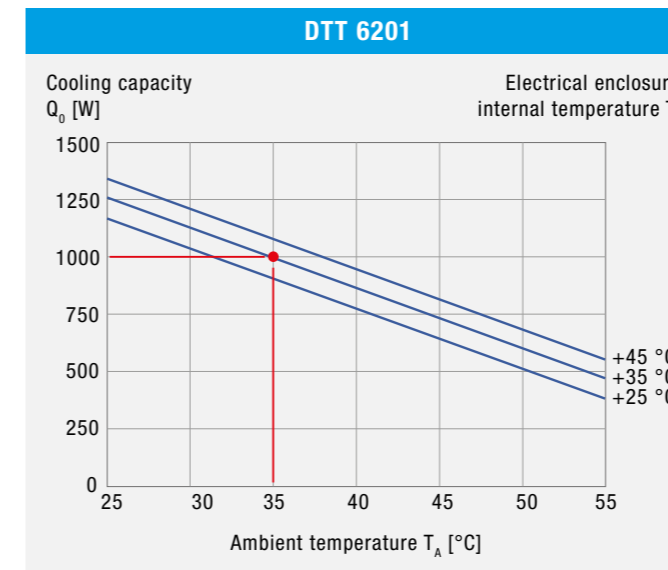
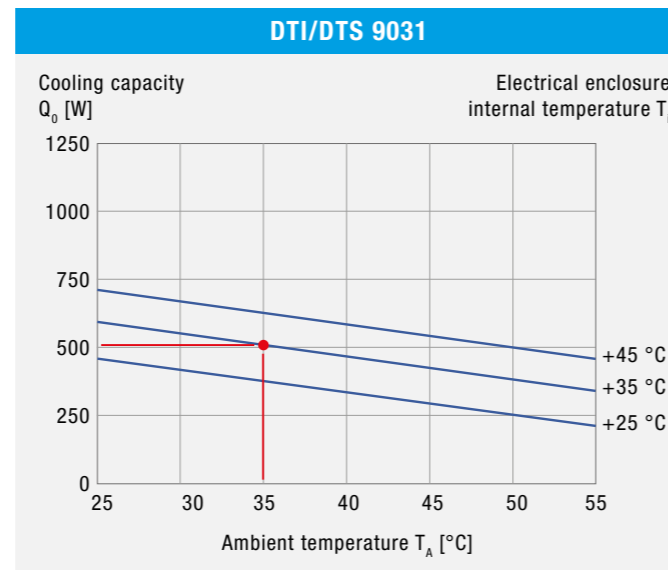
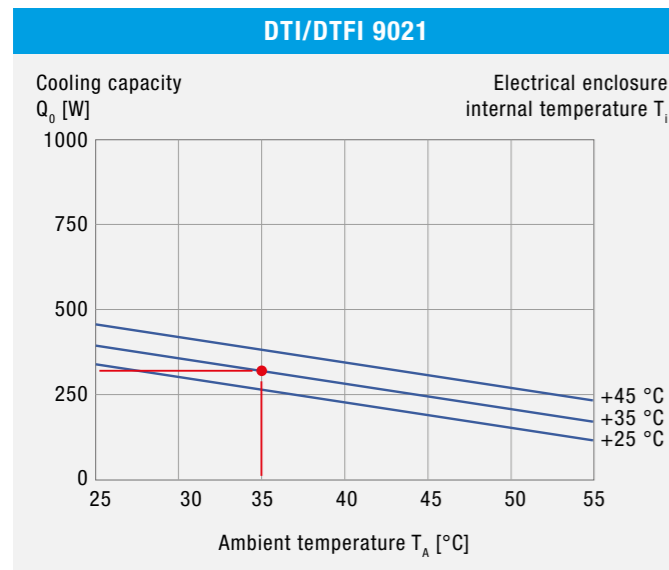
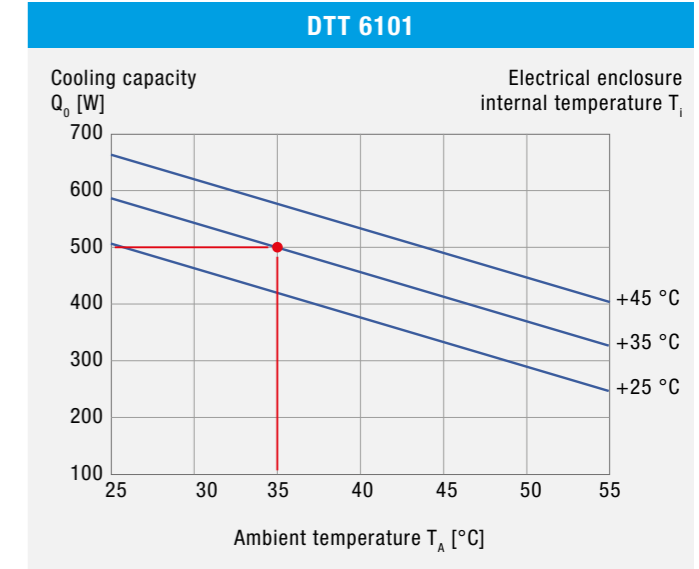
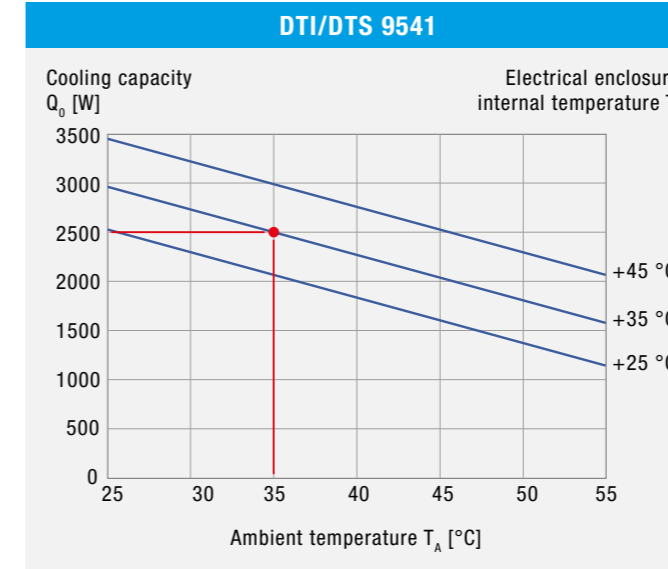
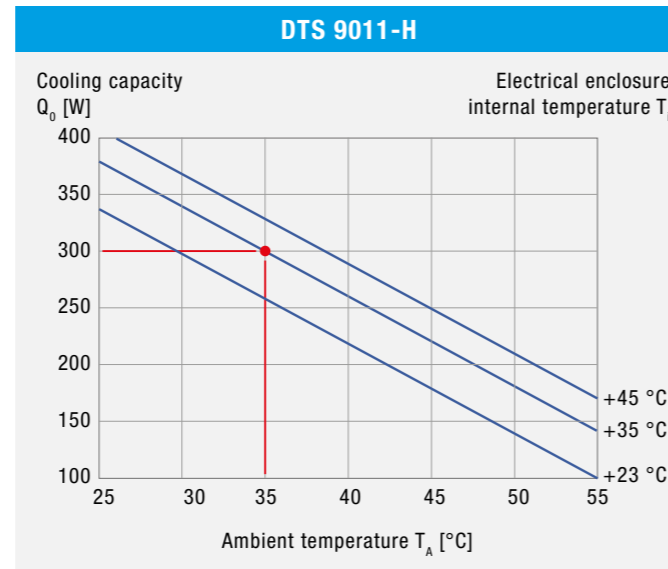
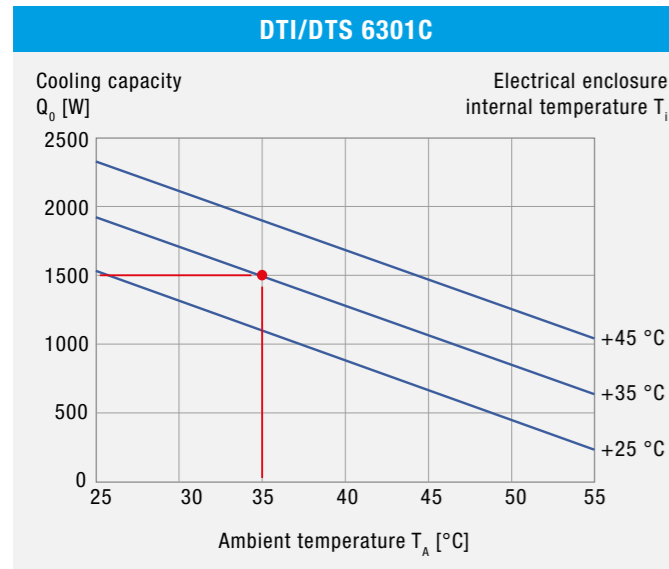
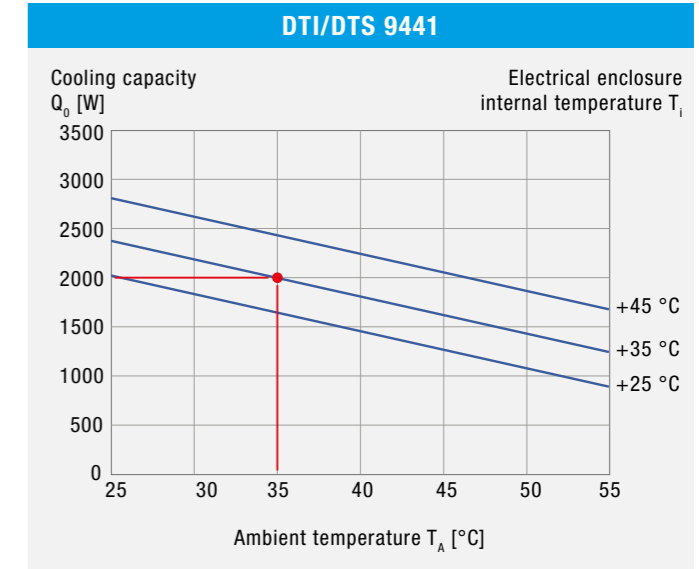
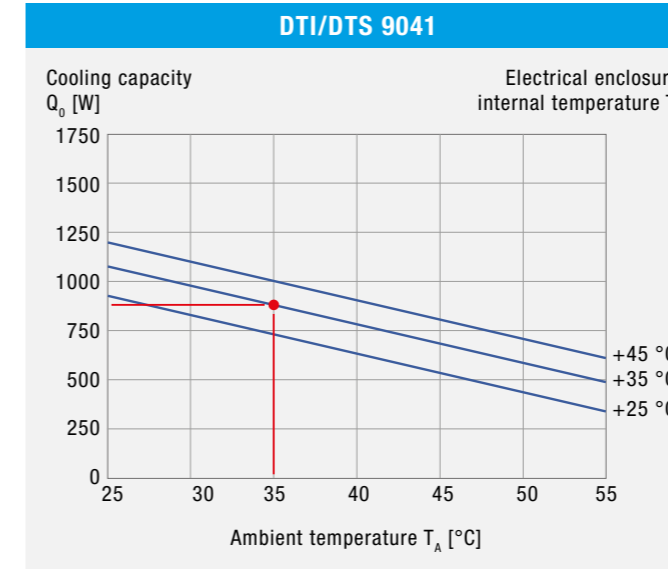

# COOLING CAPACITY

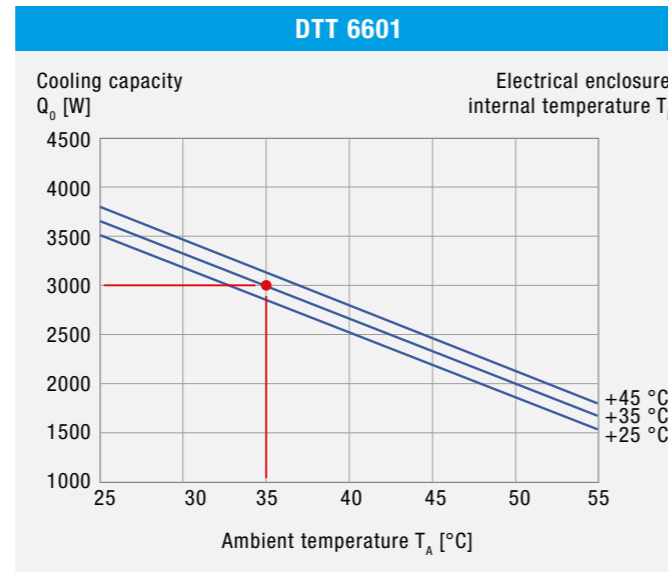
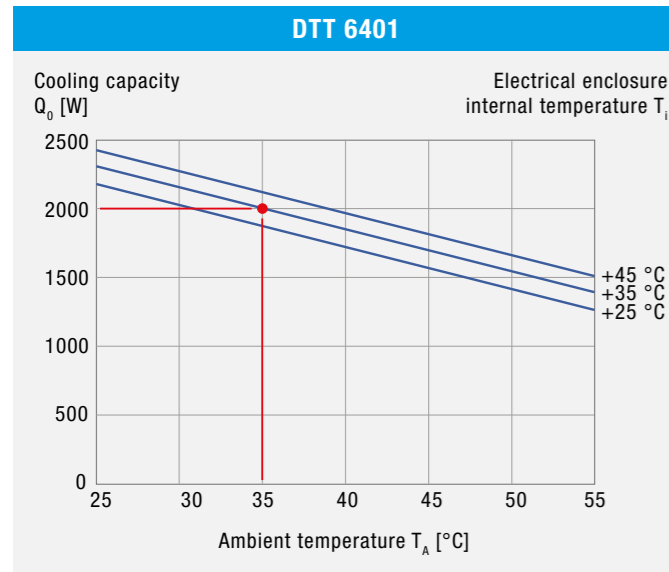

# COOLING CAPACITY

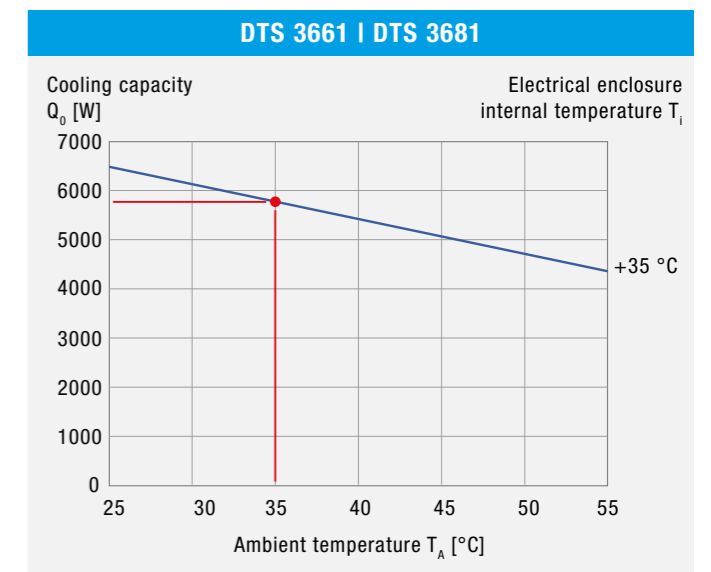
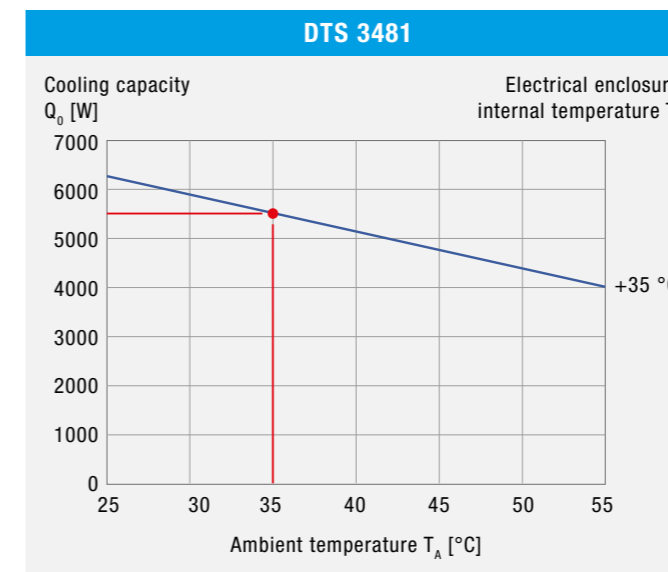
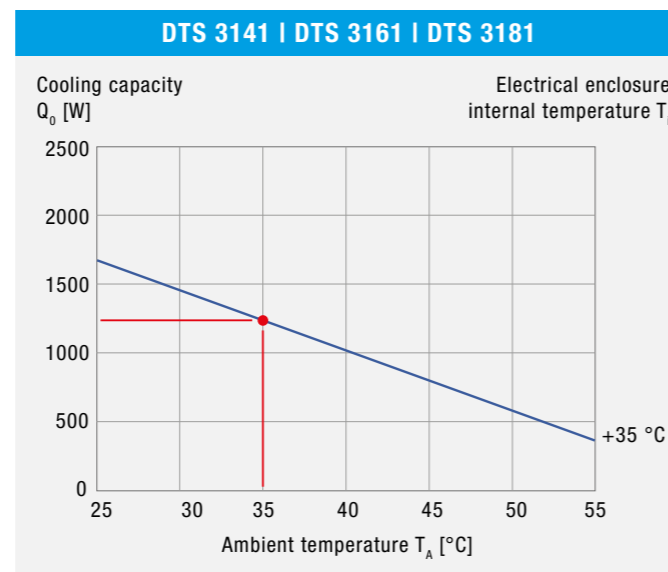
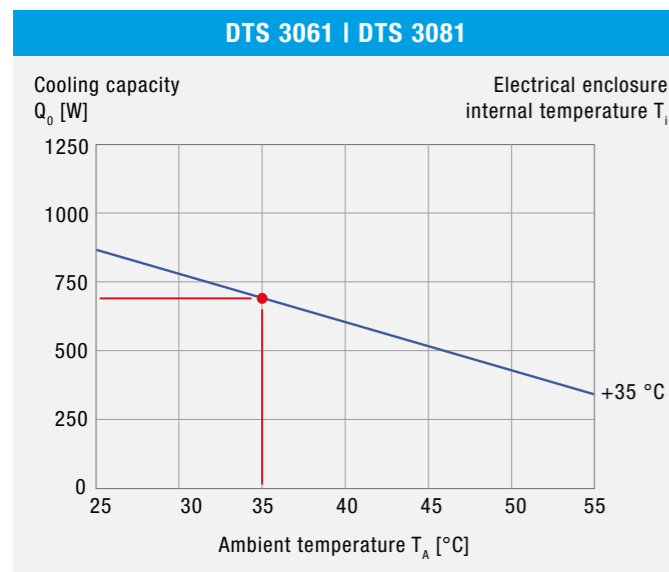
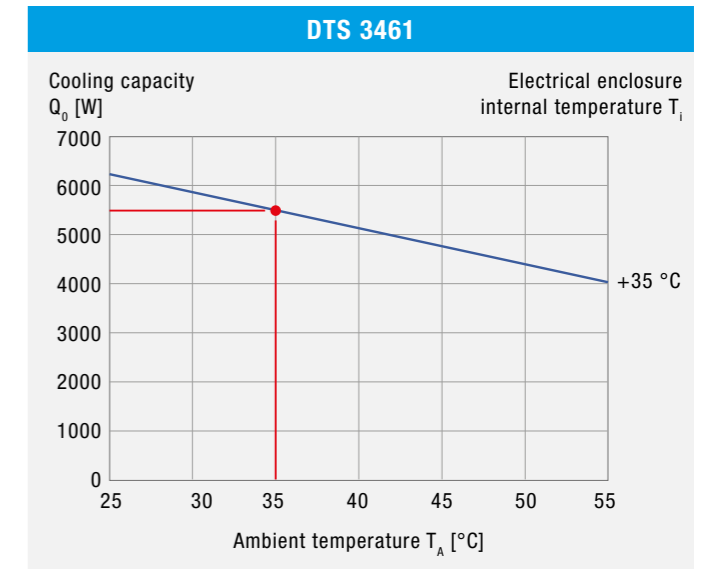
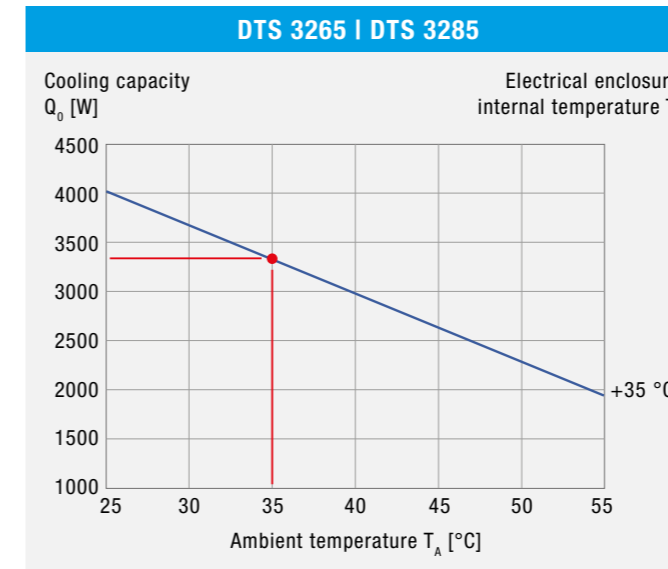
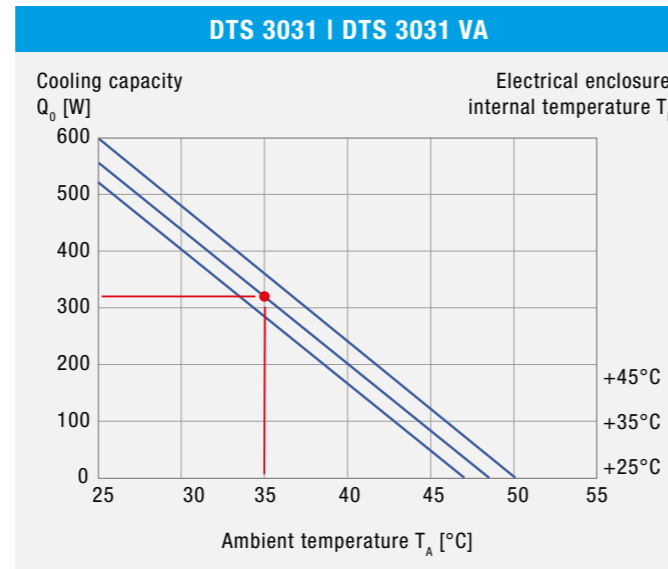
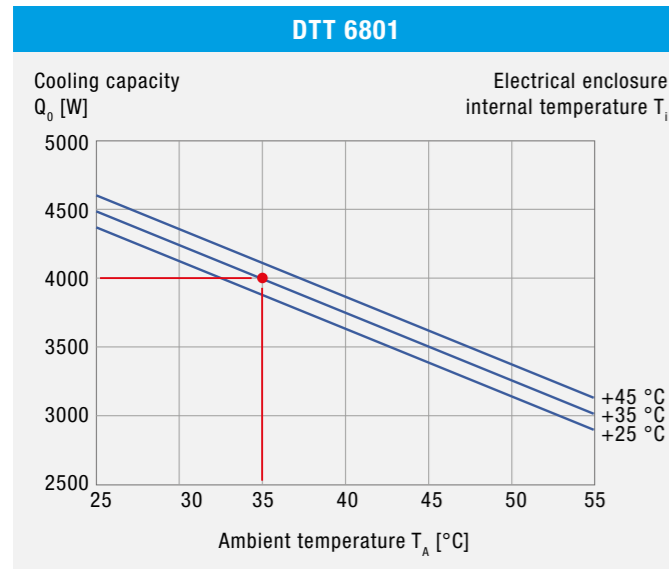
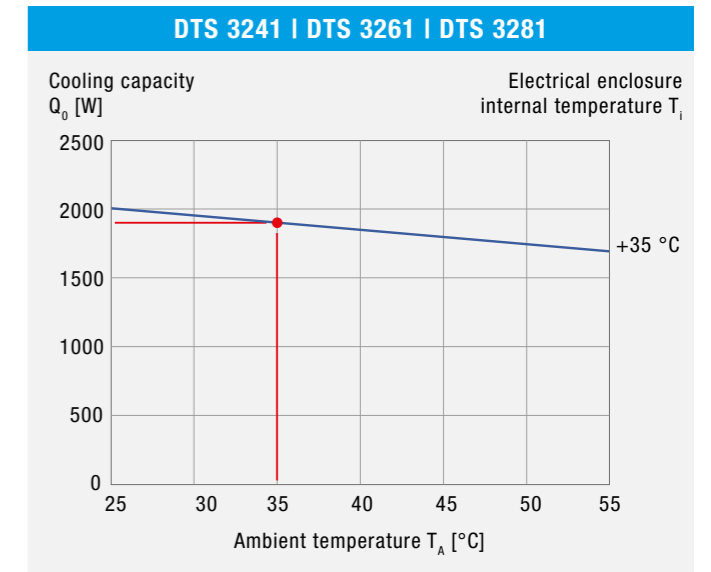
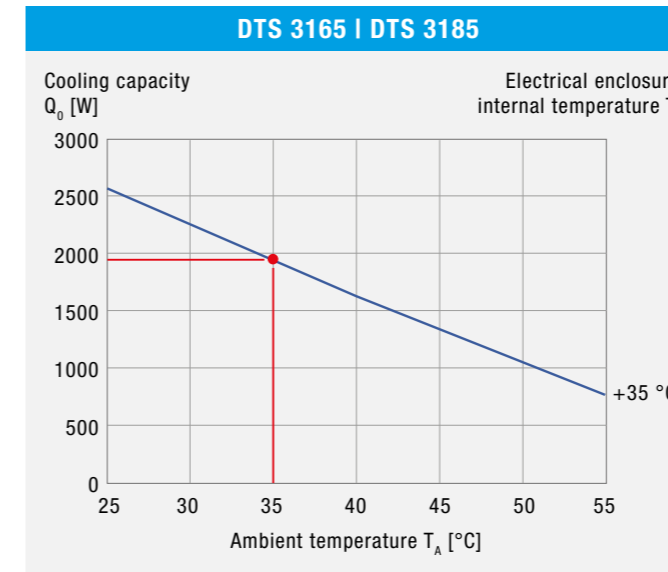

## COOLING CAPACITY

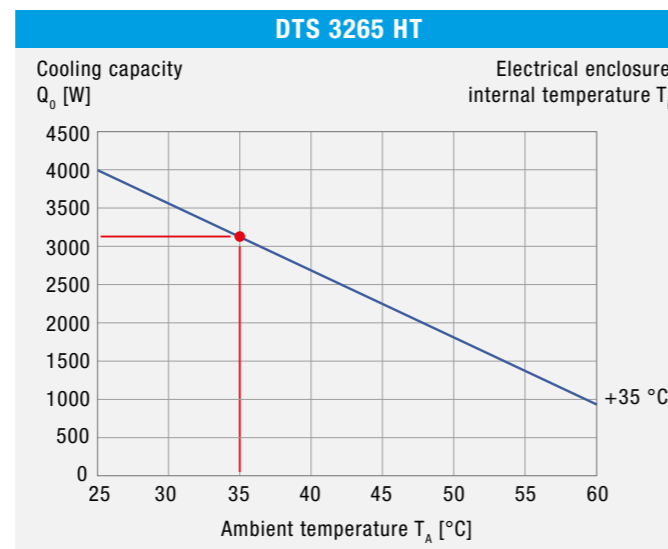
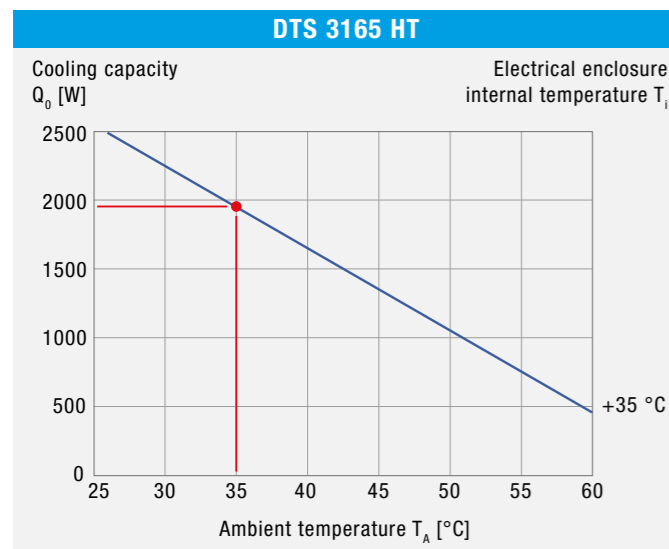
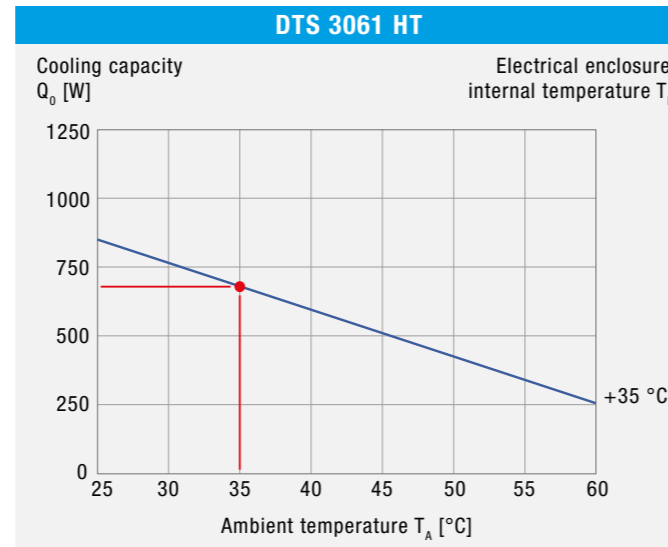
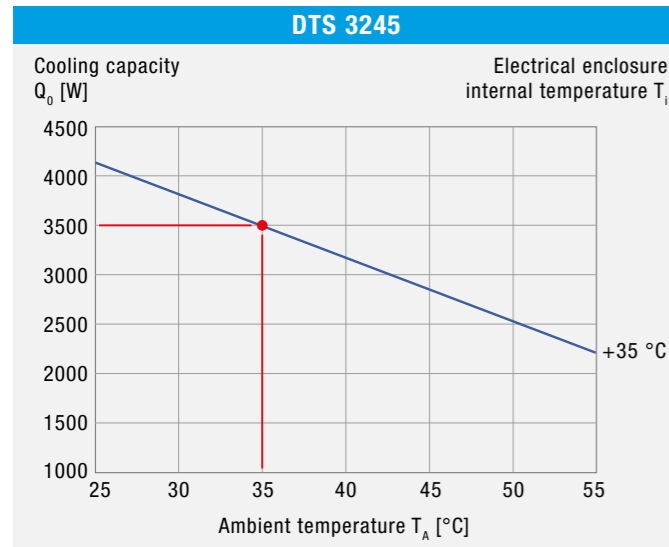

## COOLING CAPACITY

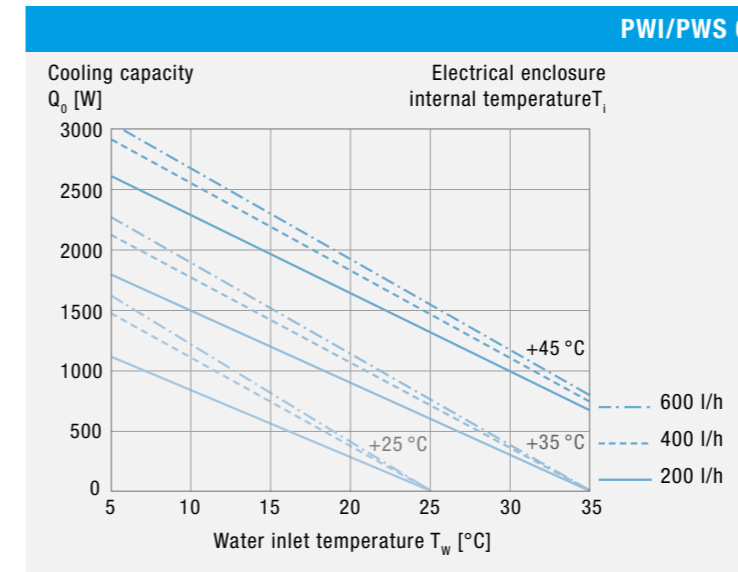

## PRESSURE LOSS

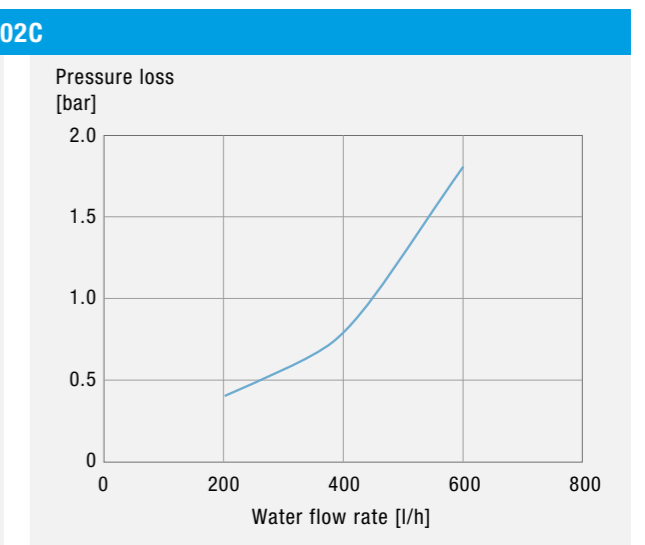
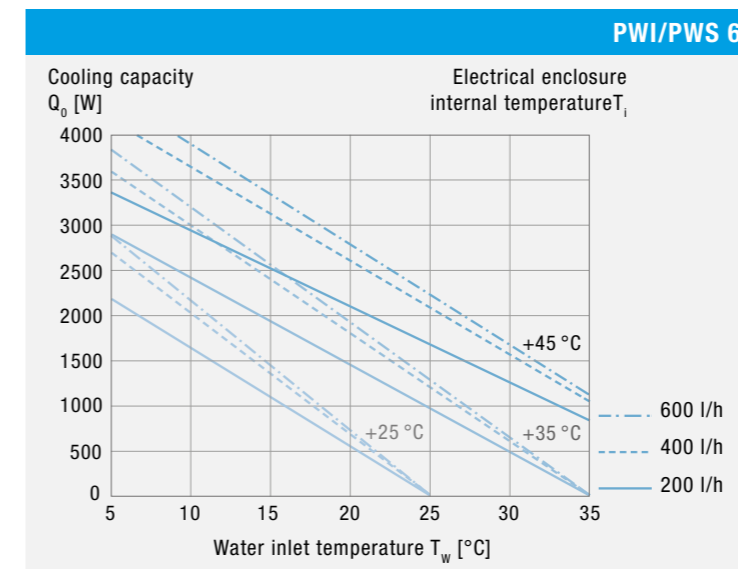
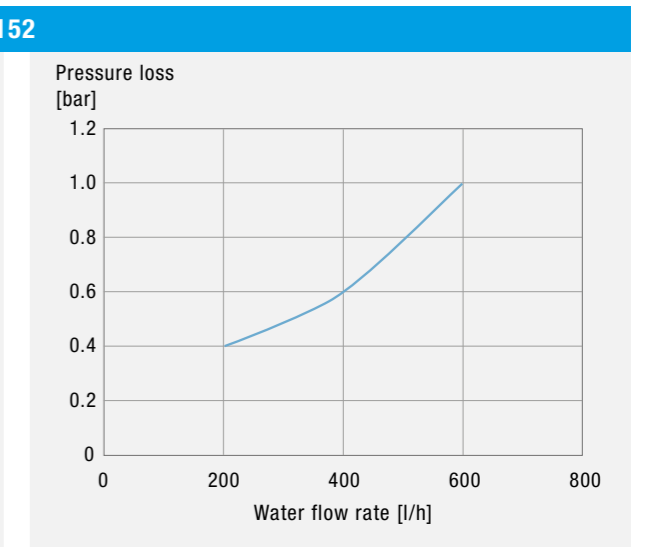

## Performance curves – Air/Water Heat Exchangers

### COOLING CAPACITY

### PRESSURE LOSS

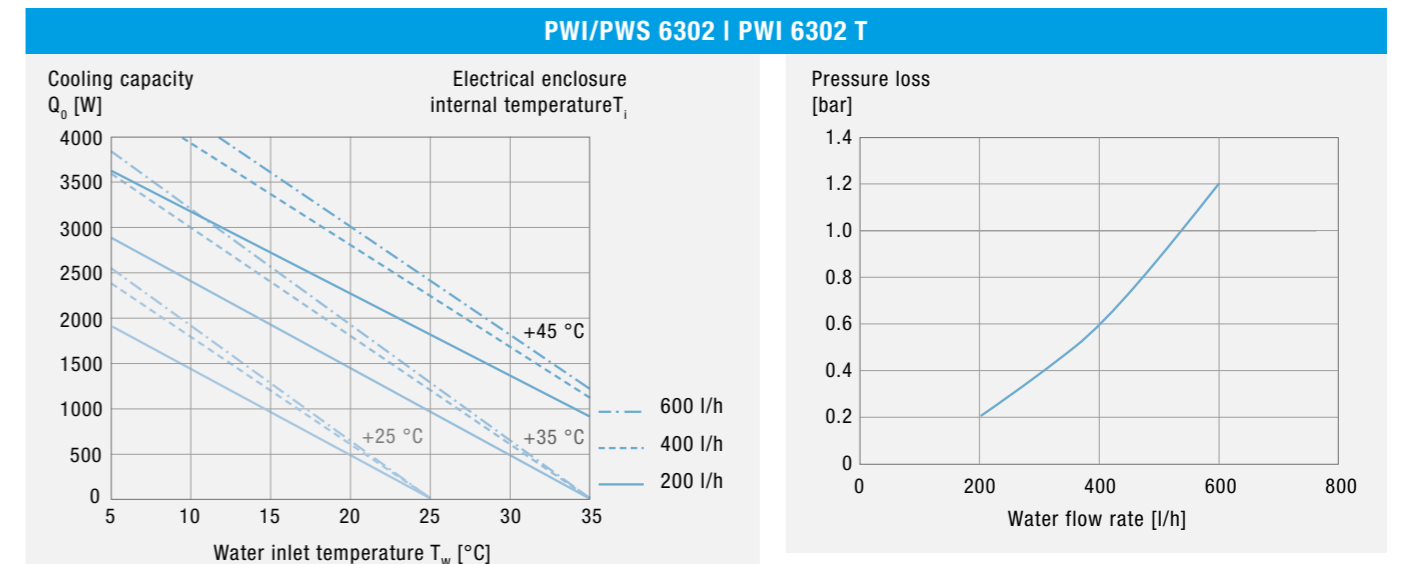
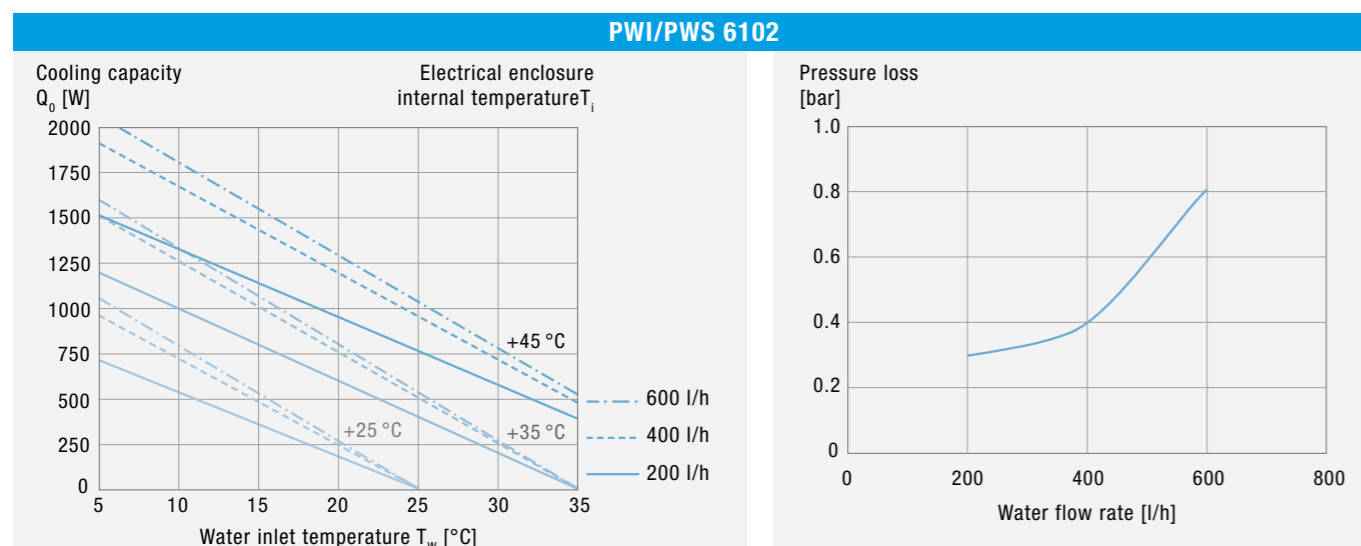

## COOLING CAPACITY

## PRESSURE LOSS

PWI/PWS 6502 | PWI 6502 T

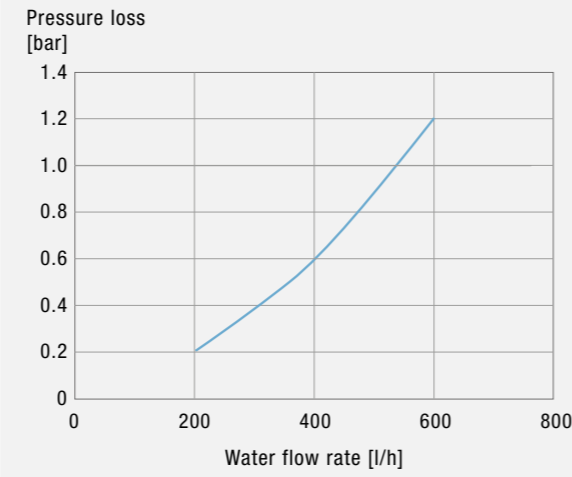
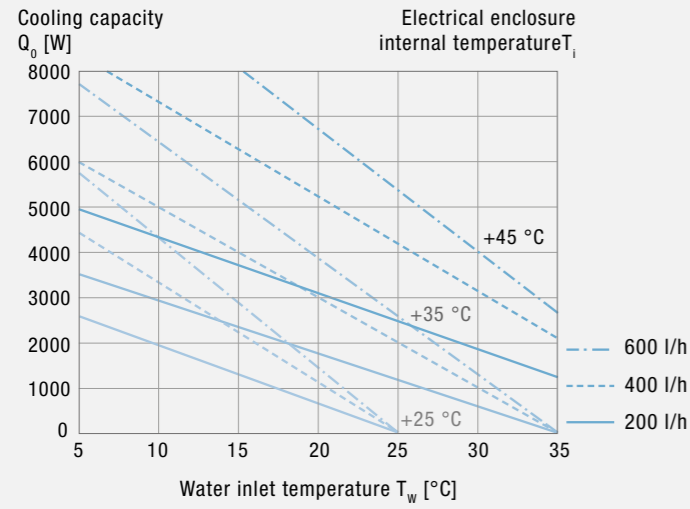

## COOLING CAPACITY

## PRESSURE LOSS

PWS 7152

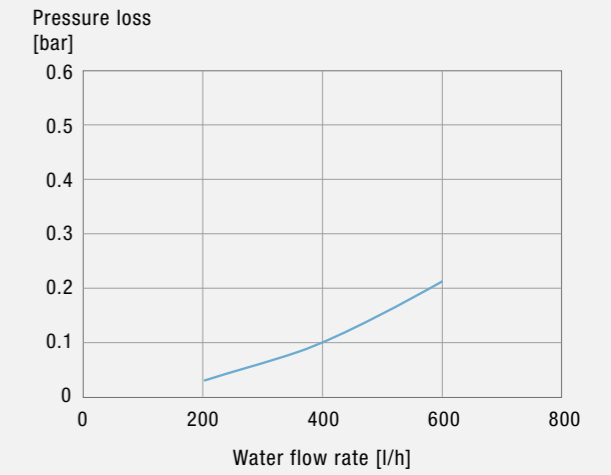
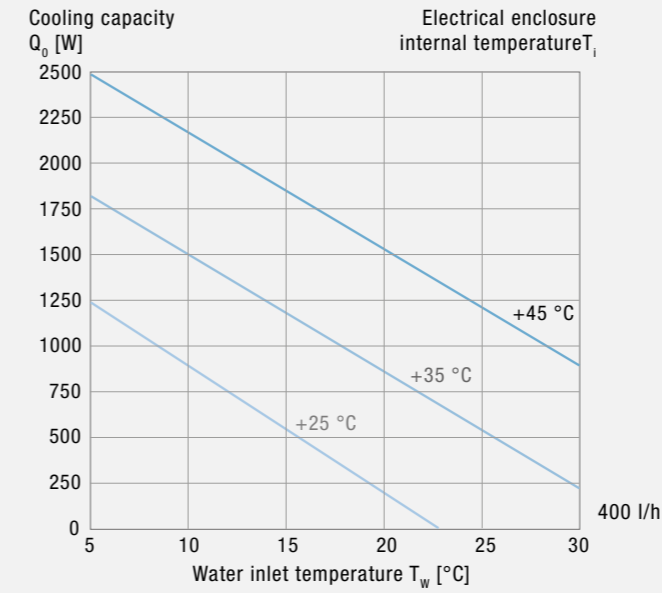

PWS 7062

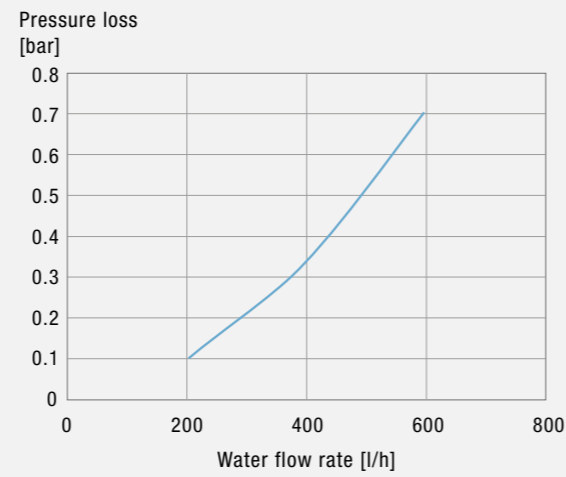
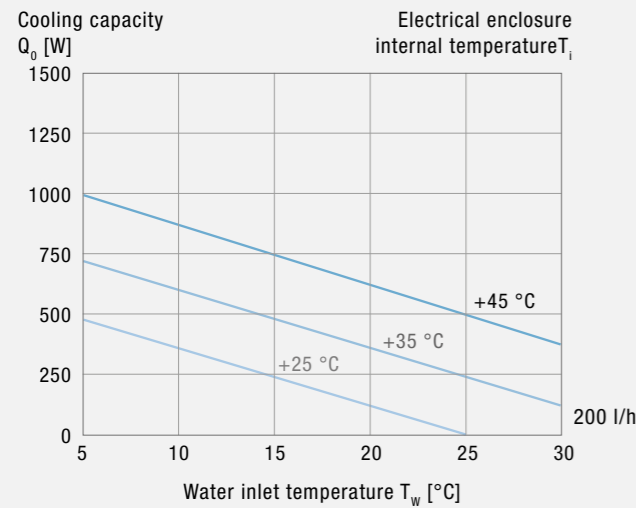

PWS 7332

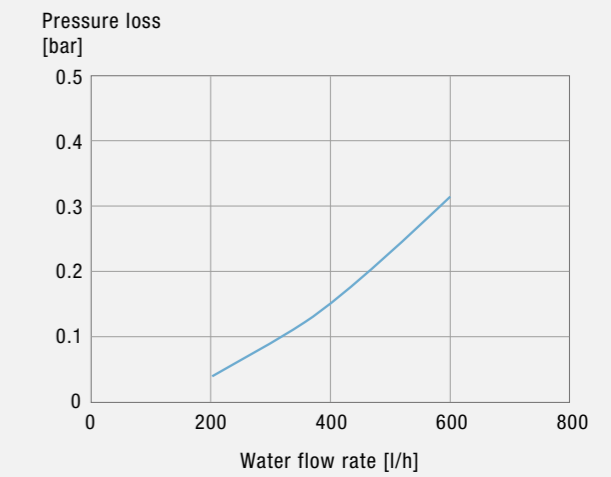
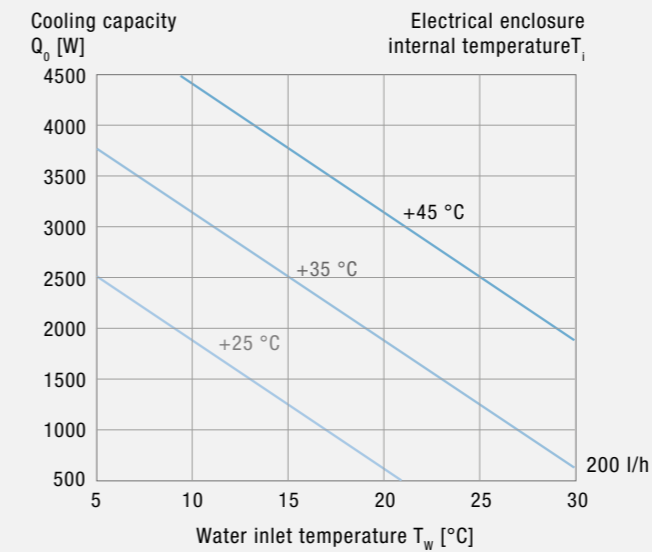

PWS 7102

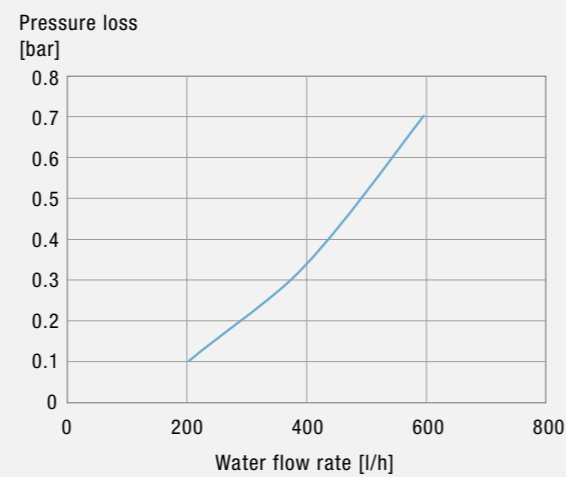
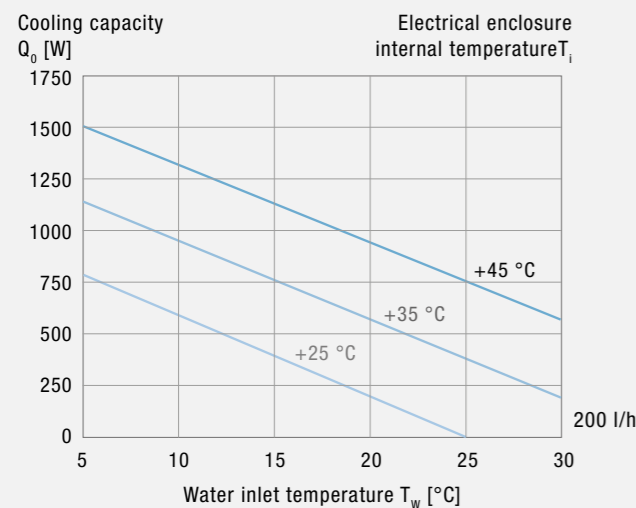

PWS 7502

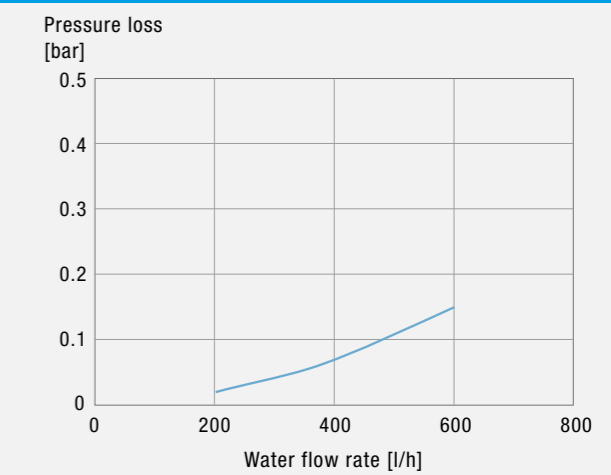
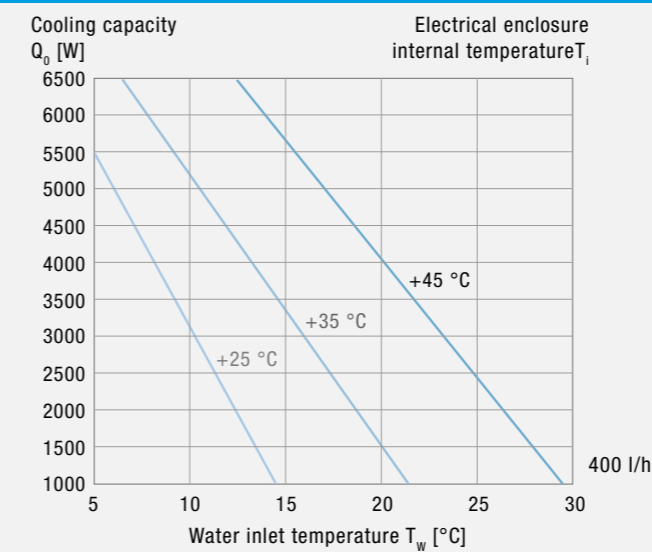

## COOLING CAPACITY

## PRESSURE LOSS

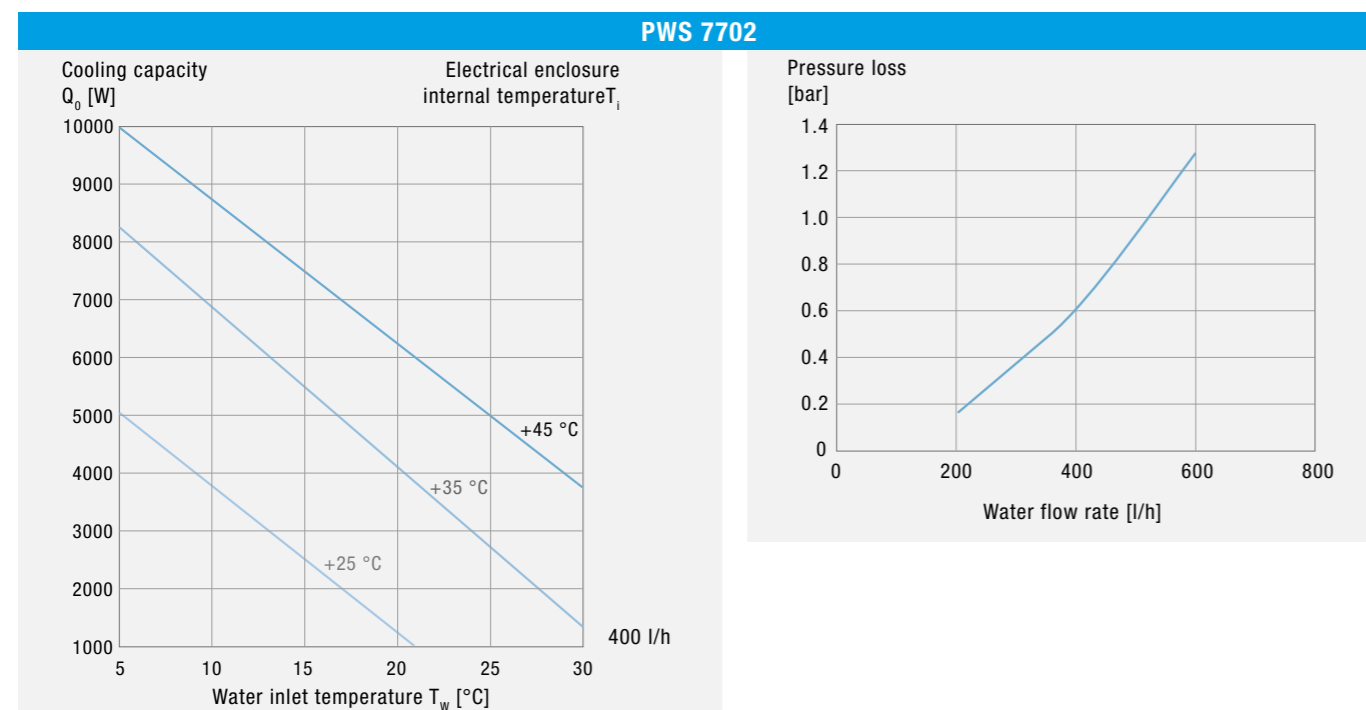
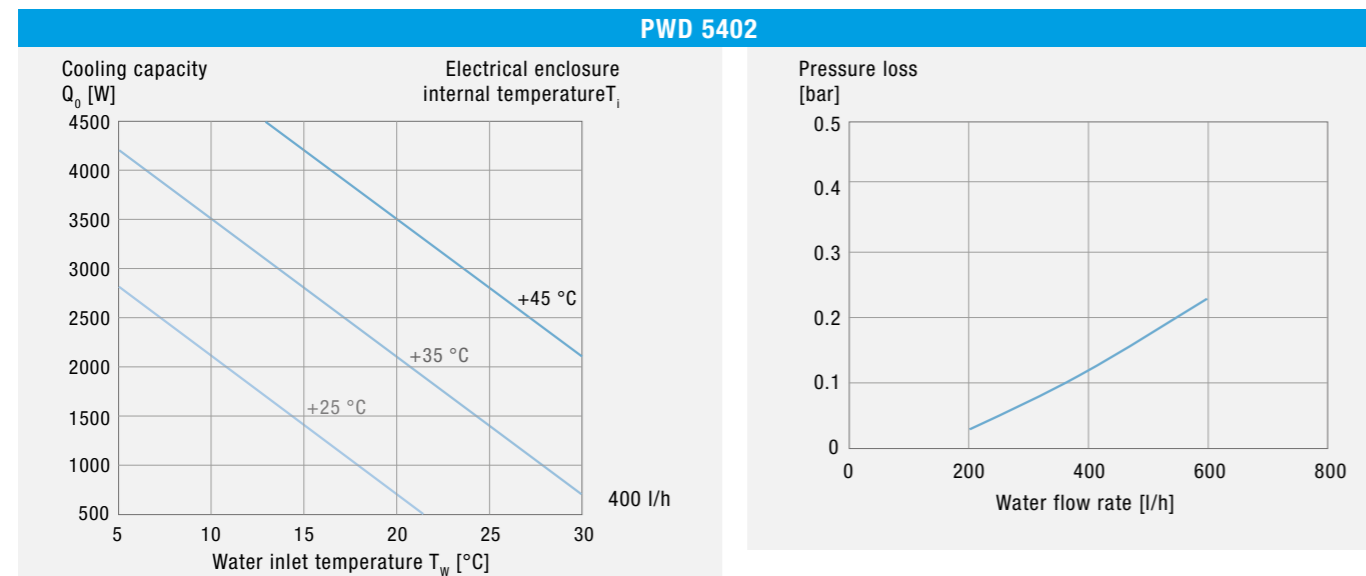
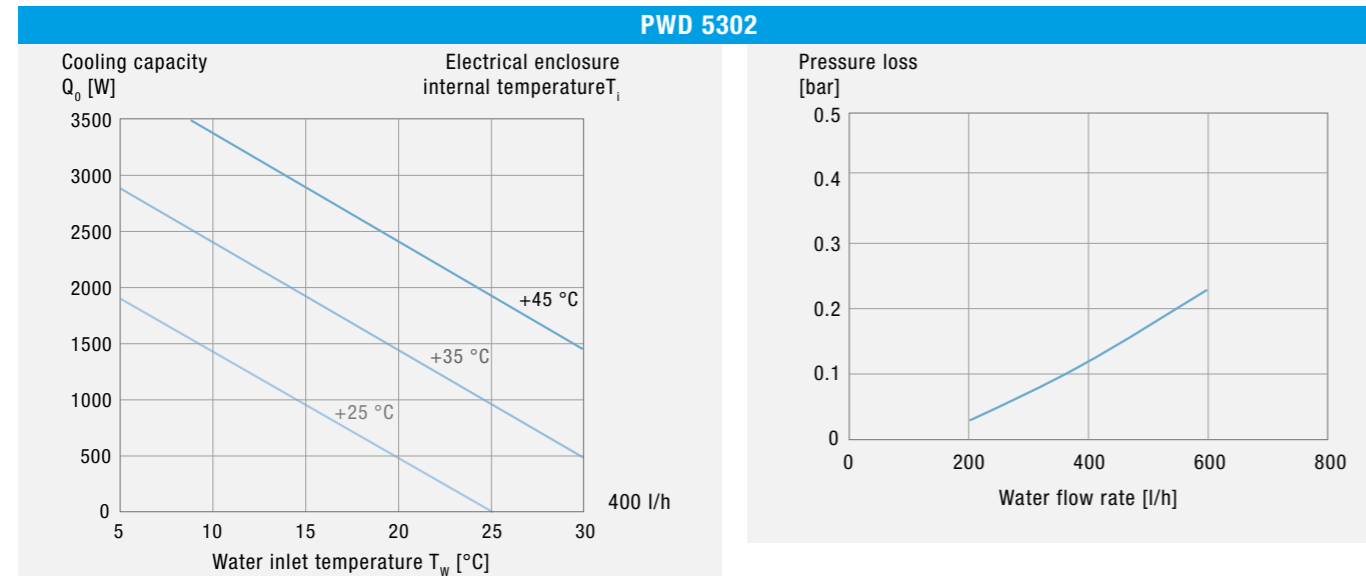

## COOLING CAPACITY

## PRESSURE LOSS

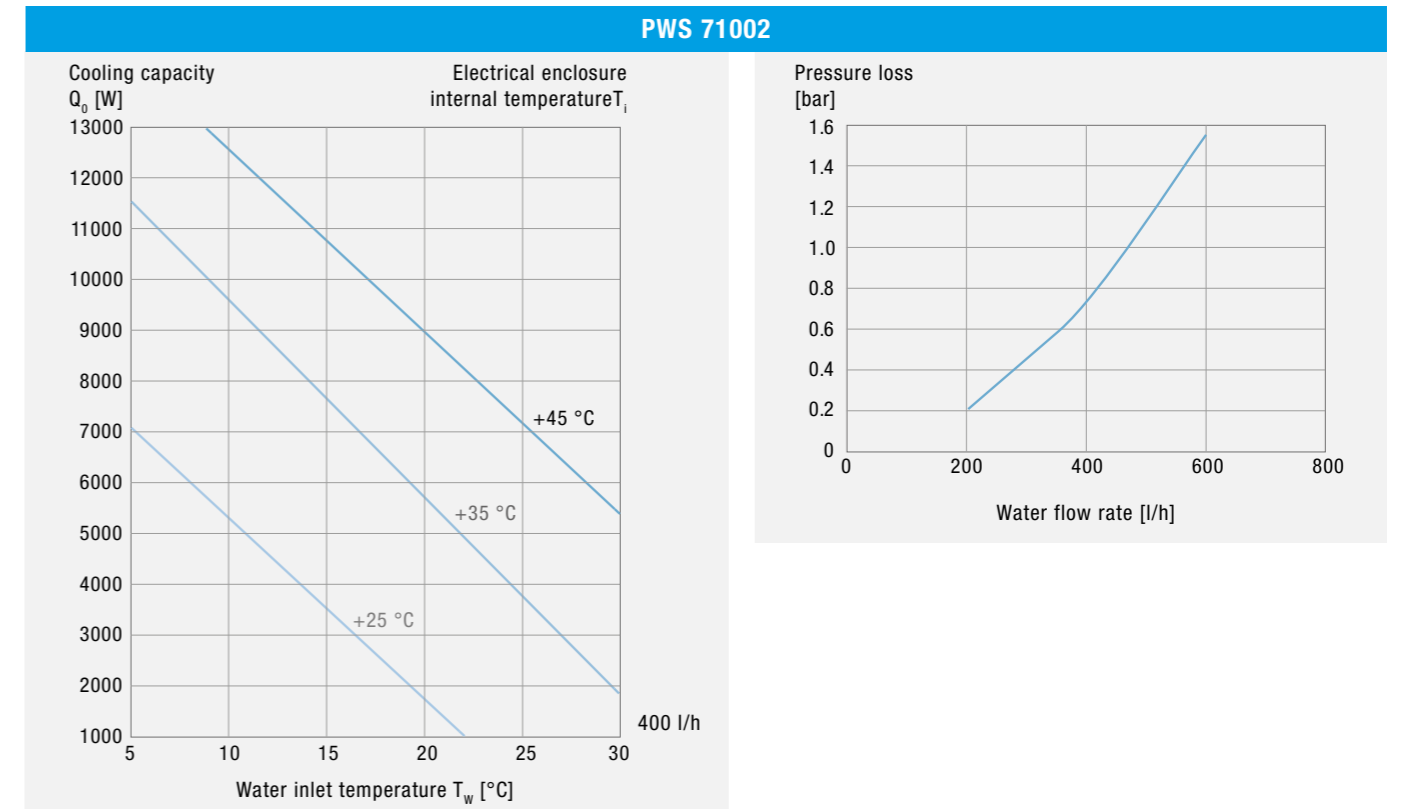

## Performance curves Chillers

## COOLING CAPACITY

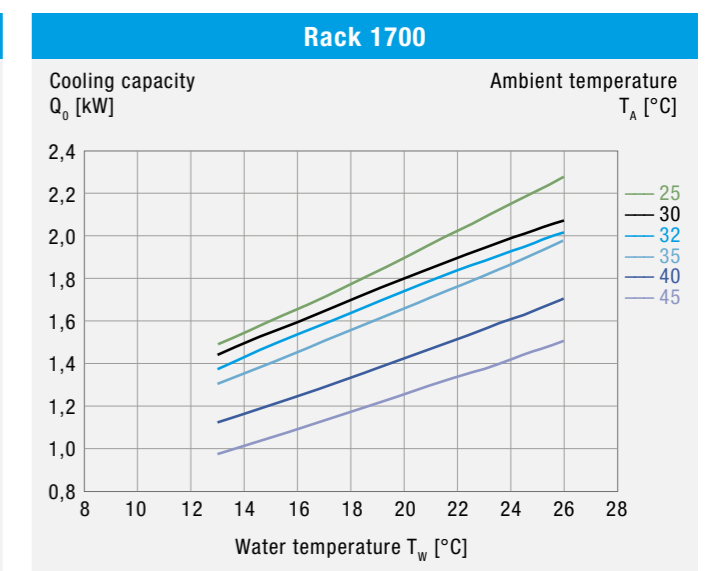
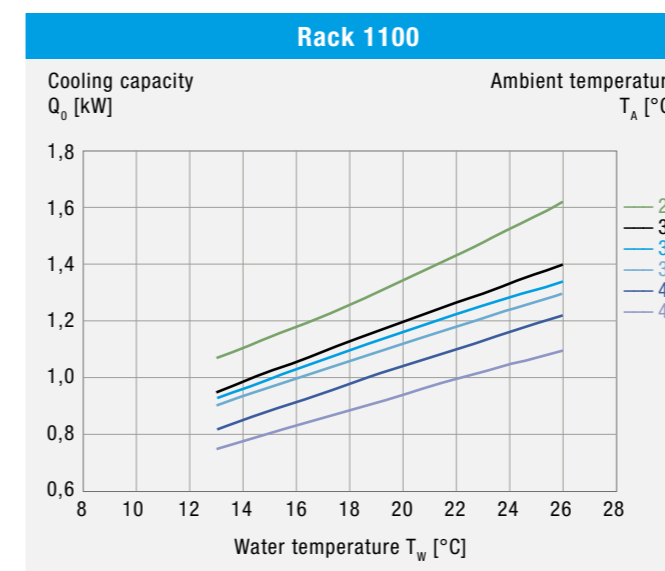

# COOLING CAPACITY

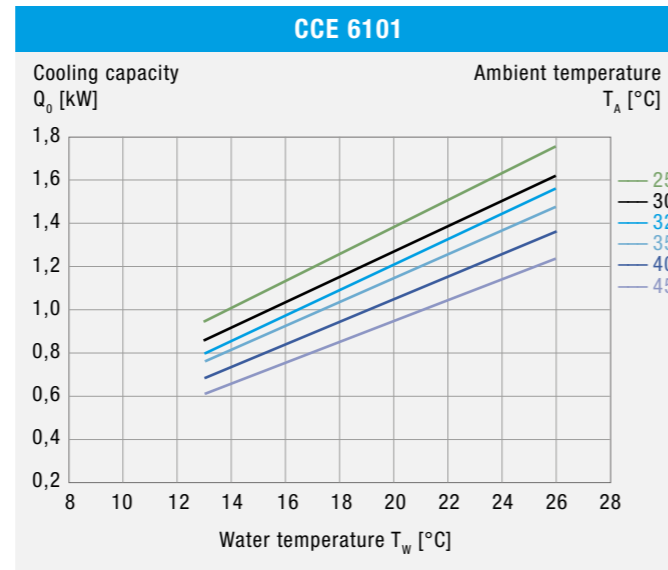
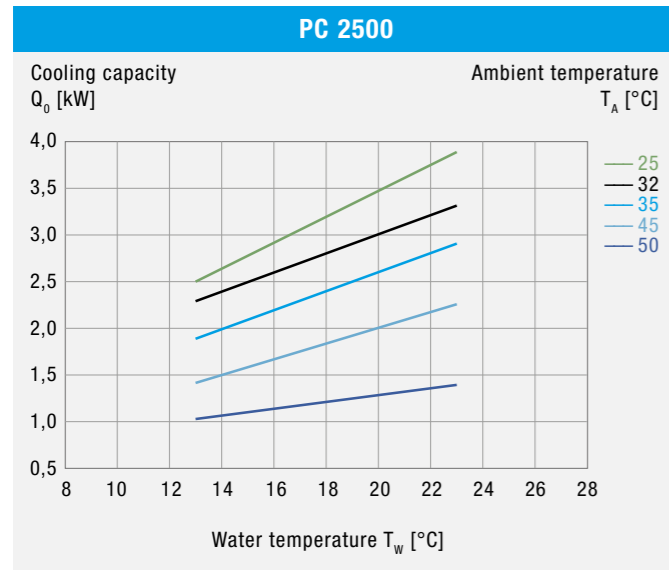

# COOLING CAPACITY

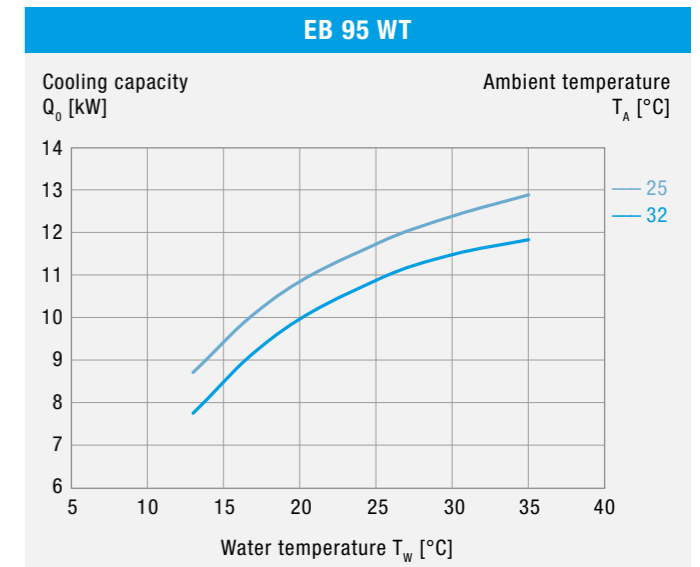
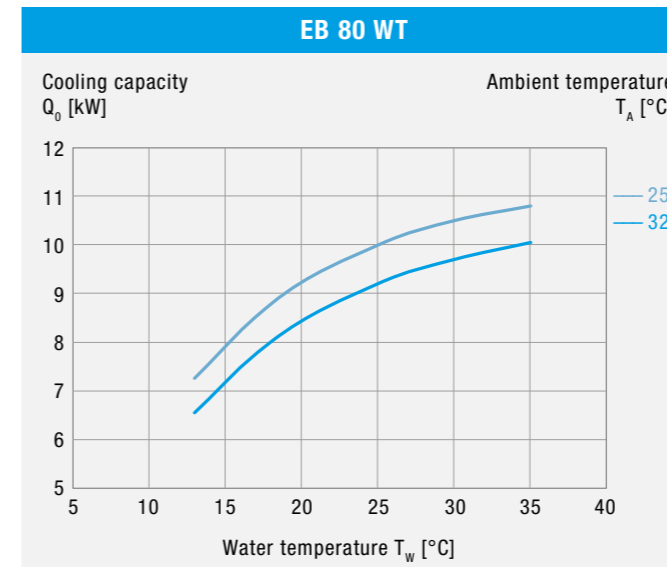
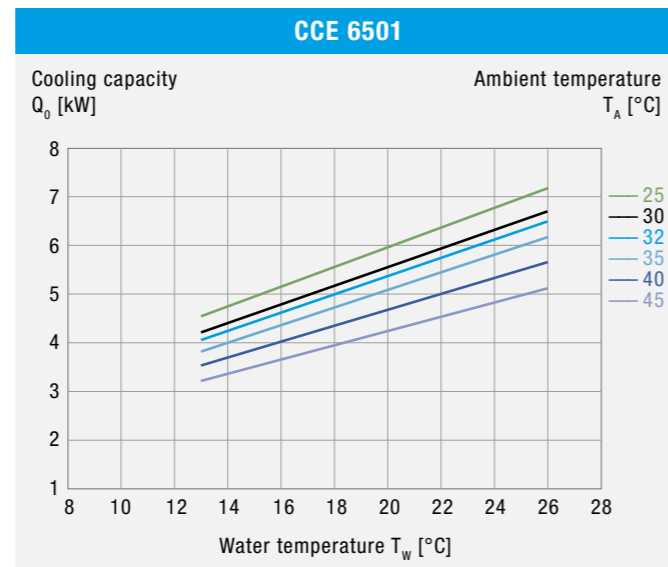
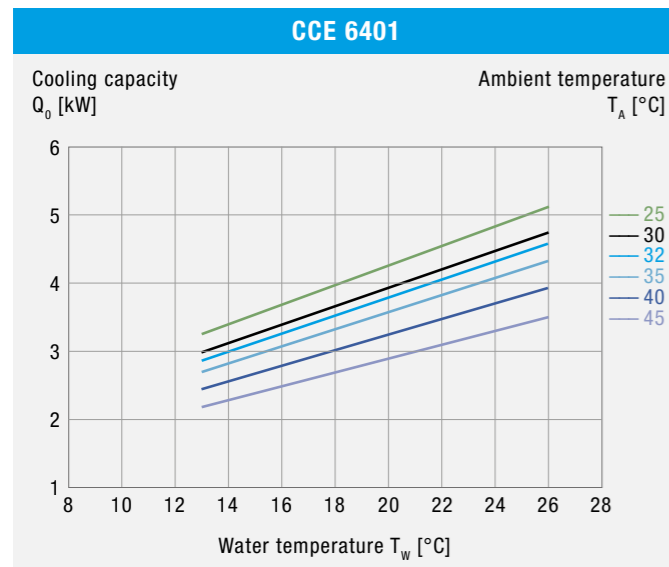
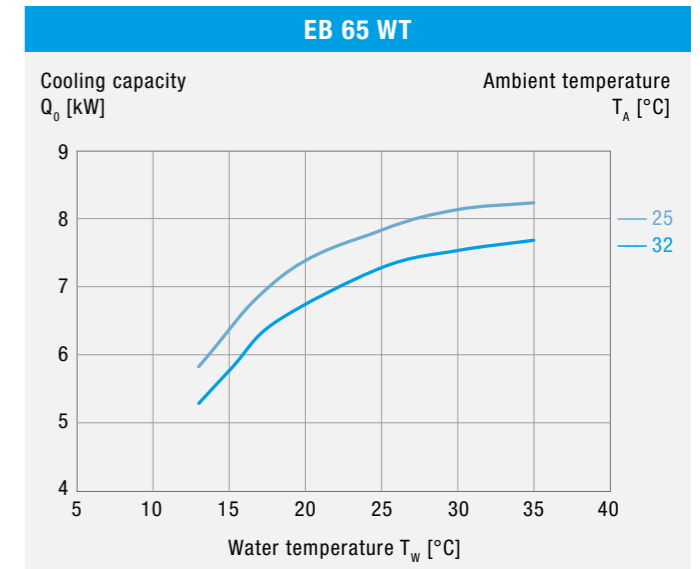
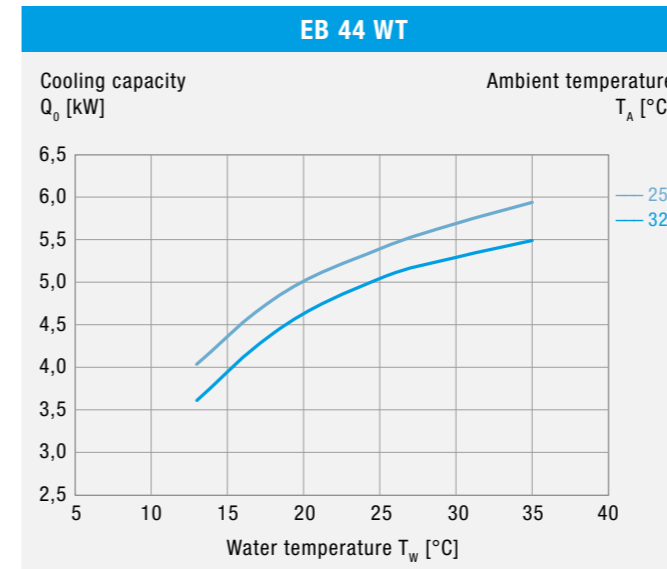
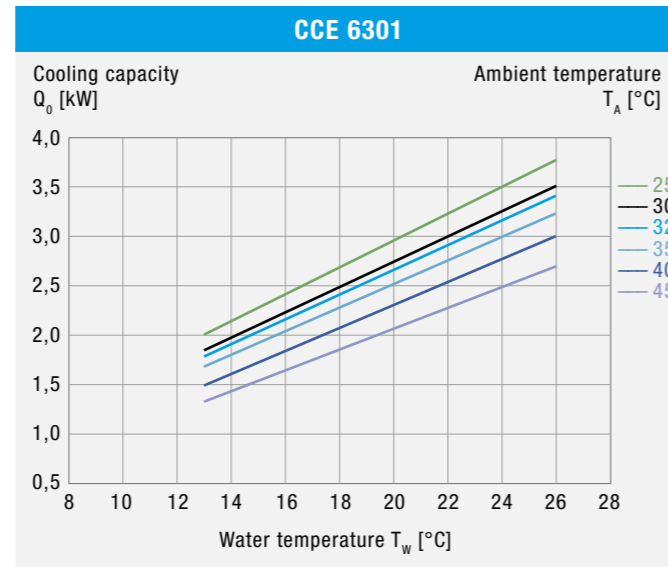
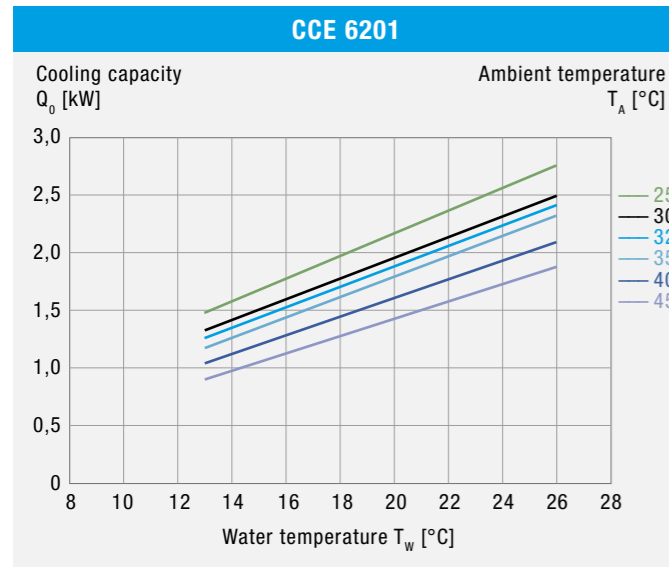
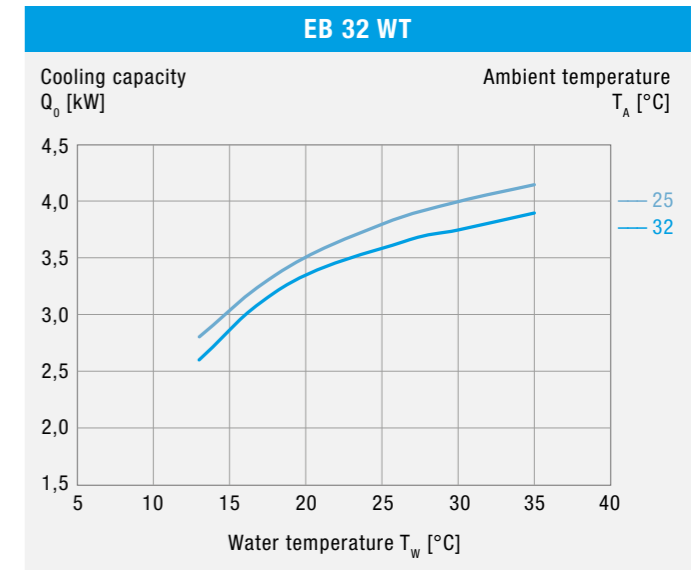
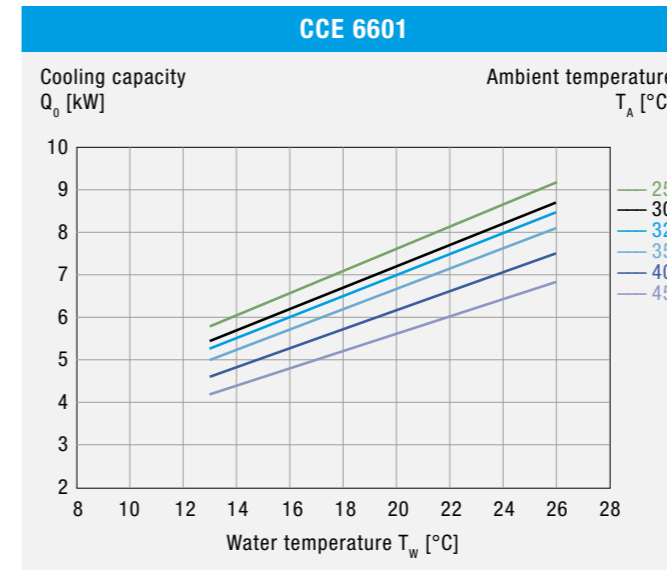

**EB 2.0:** The performance curves include standard pump losses and refer to operation at 50 Hz with water. Compared to values indicated for ambient temperature of 32 °C, capacity values will decrease by approximately 20 % (30 %) during operation at 40 °C (45 °C) ambient temperature.

# COOLING CAPACITY

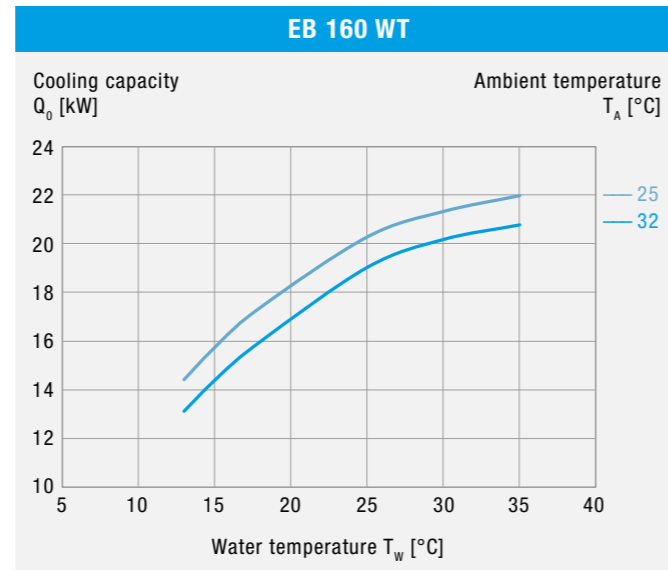
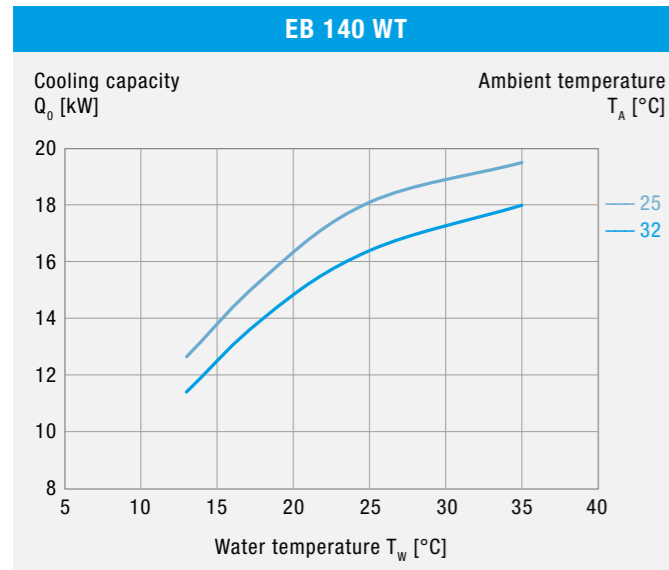

# COOLING CAPACITY

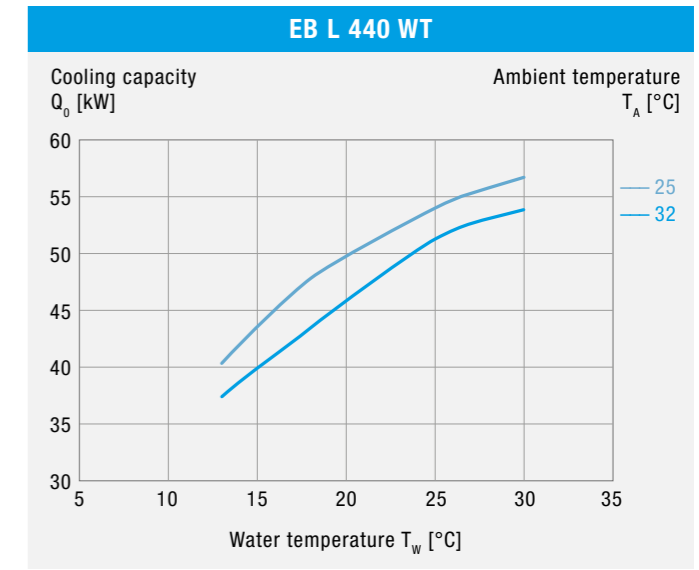
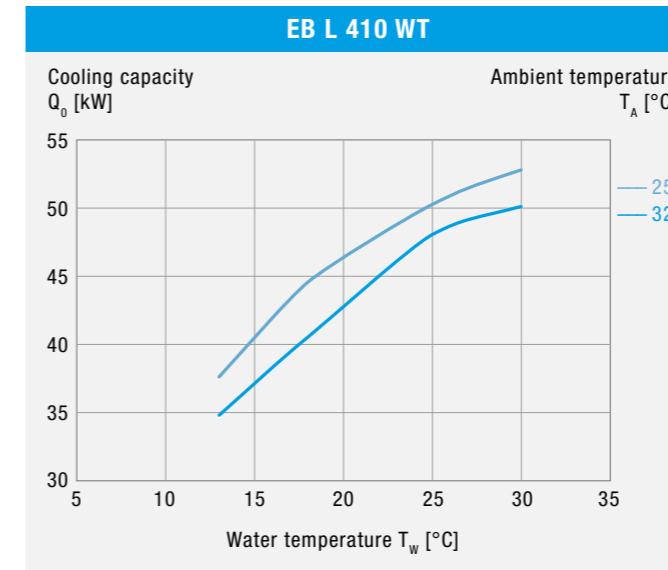

EB 2.0: The performance curves include standard pump losses and refer to operation at 50 Hz with water. Compared to values indicated for ambient temperature of 32 °C, capacity values will decrease by approximately 20 % (30 %) during operation at 40 °C (45 °C) ambient temperature.

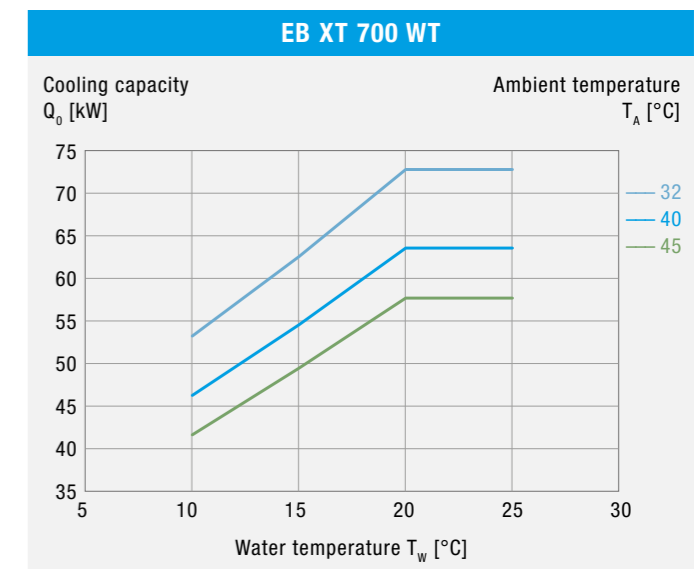
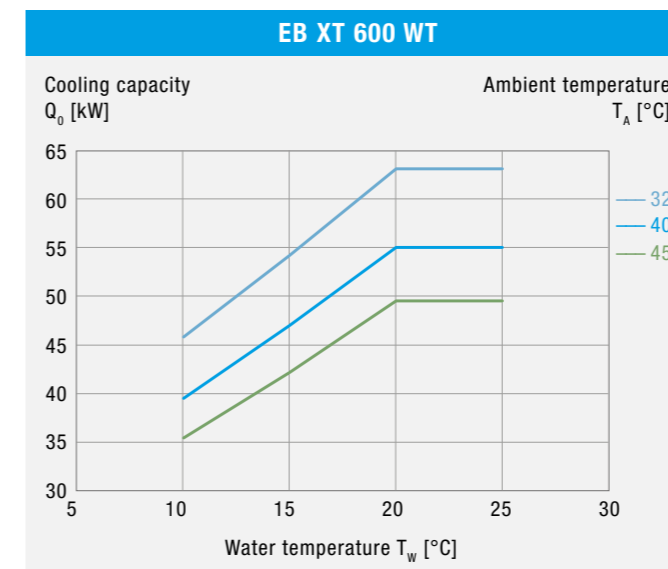
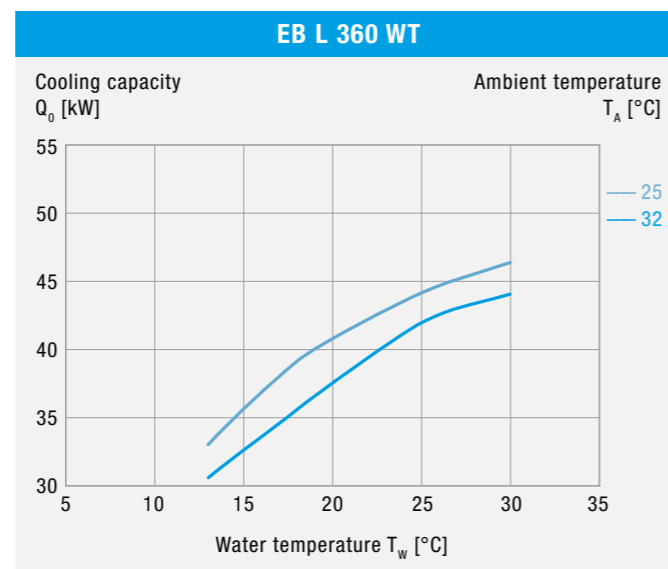
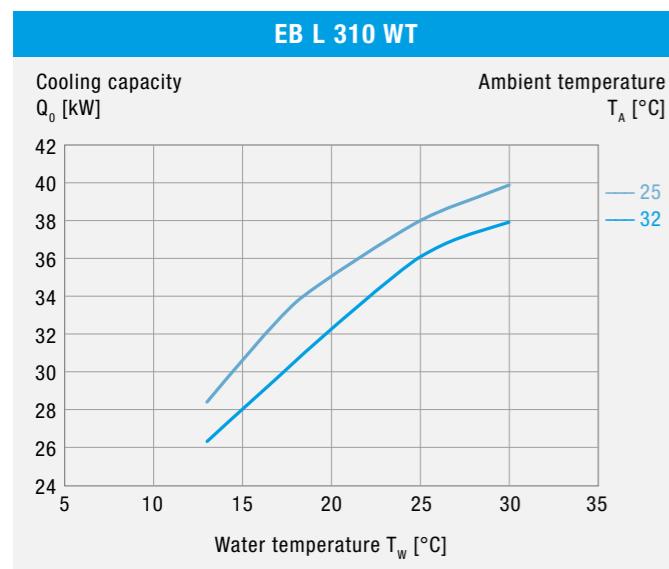
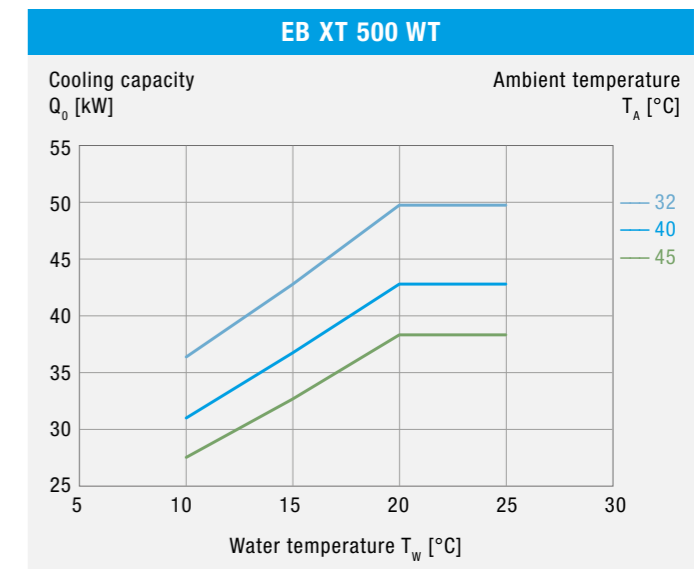
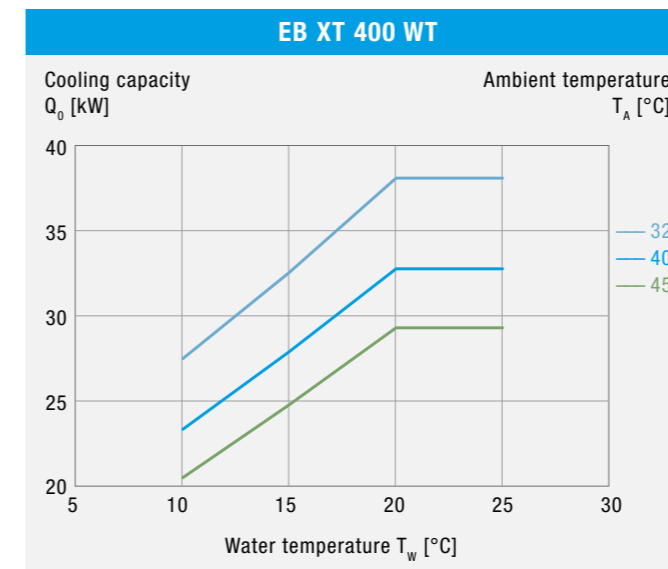
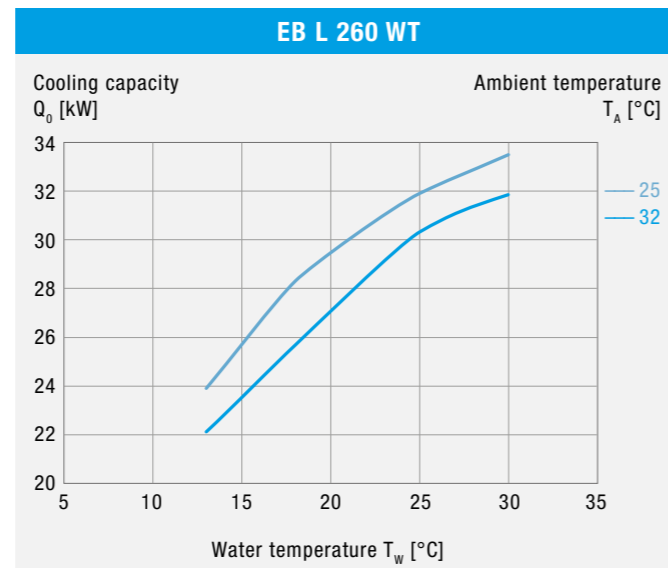
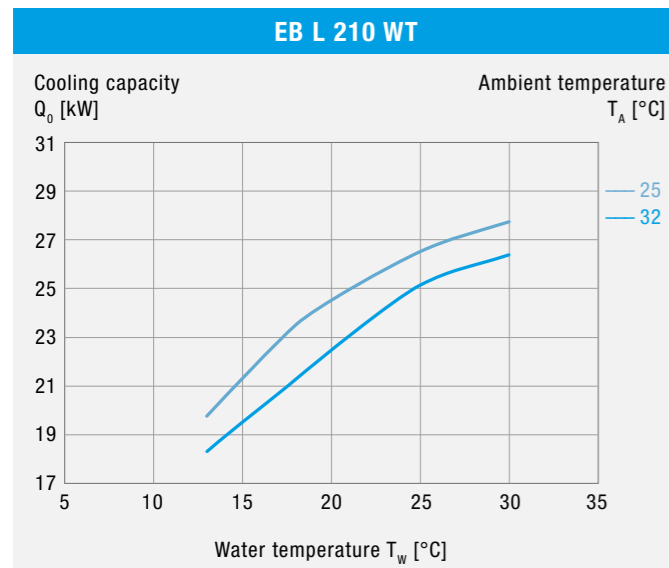

EB 2.0: The performance curves include standard pump losses and refer to operation at 50 Hz with water. Compared to values indicated for ambient temperature of 32 °C, capacity values will decrease by approximately 20 % (30 %) during operation at 40 °C (45 °C) ambient temperature.

# COOLING CAPACITY

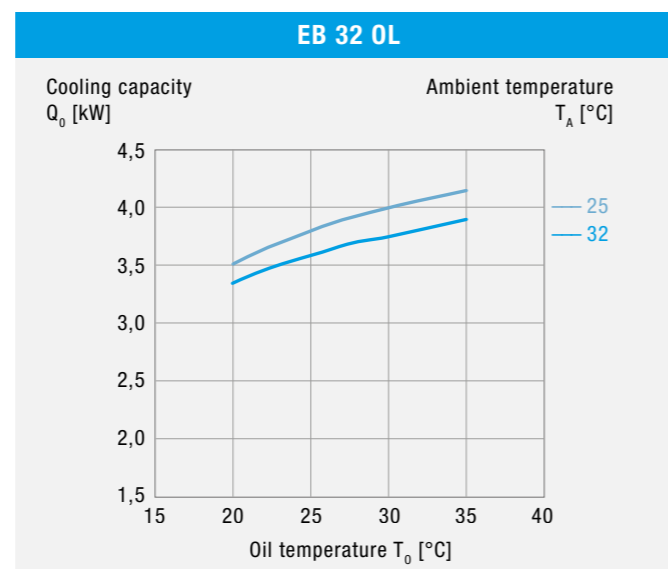
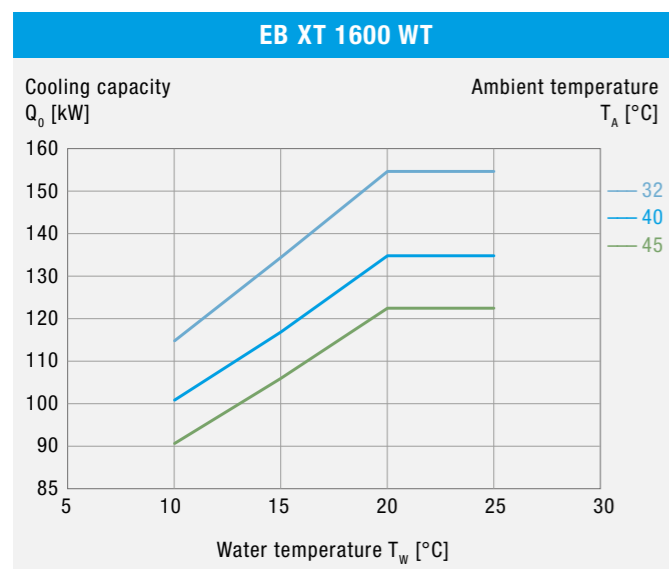
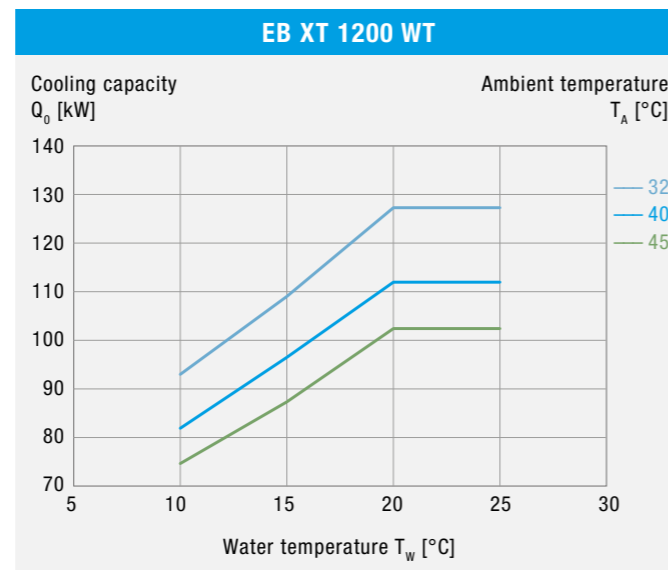
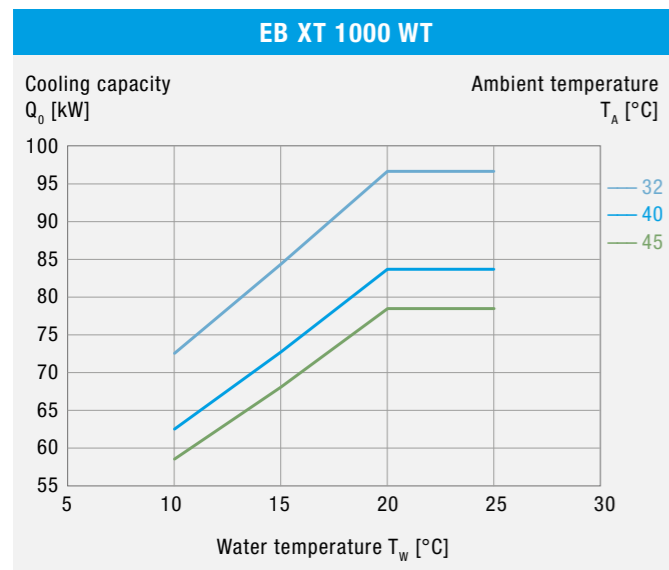
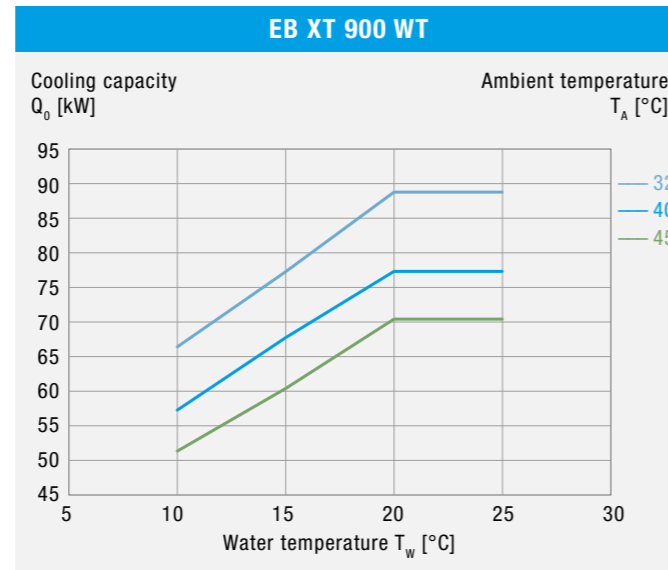
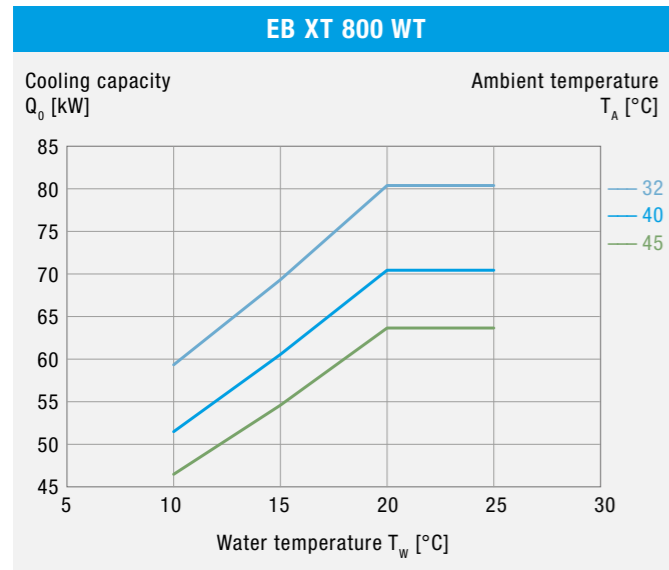

# COOLING CAPACITY

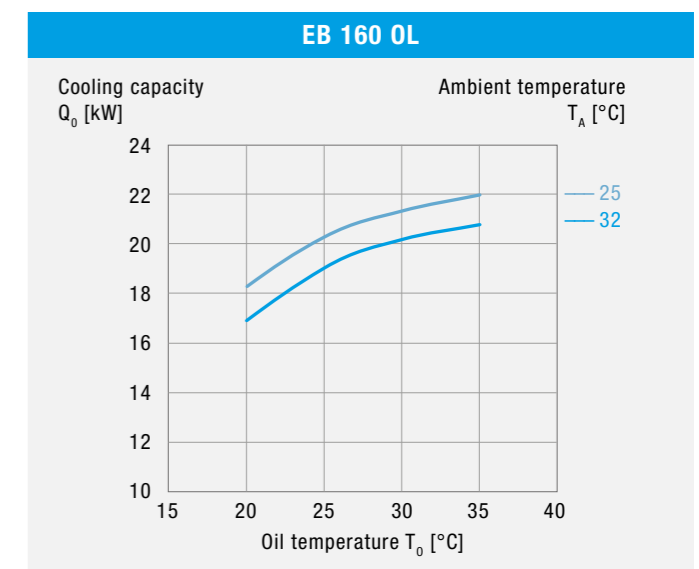
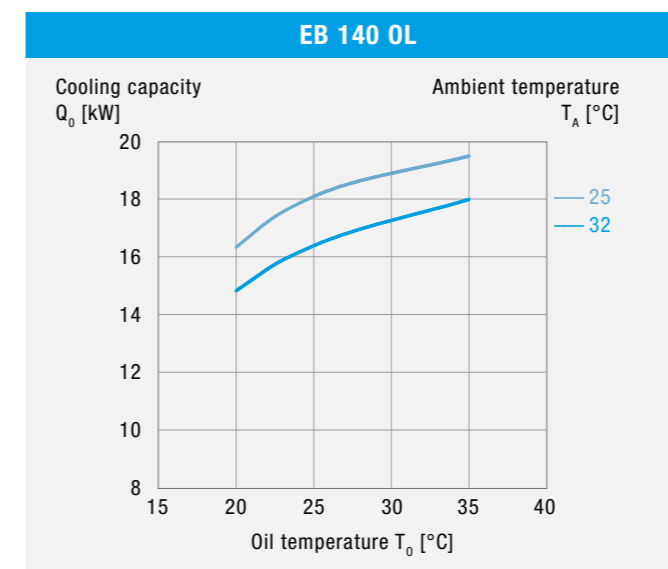
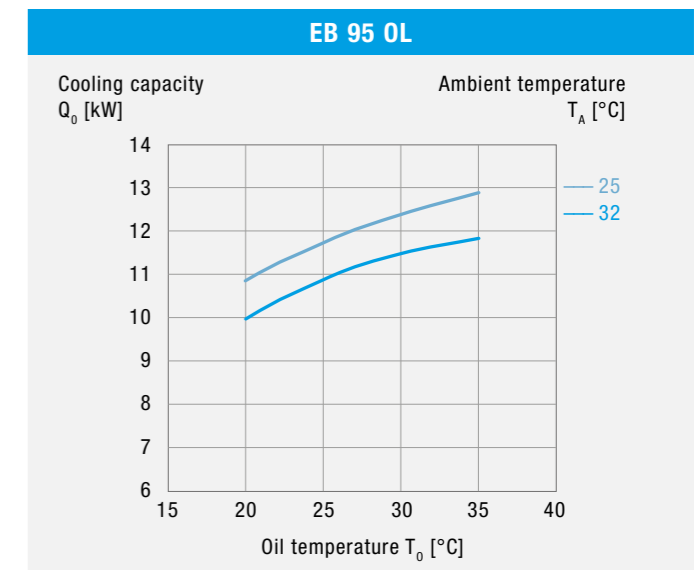
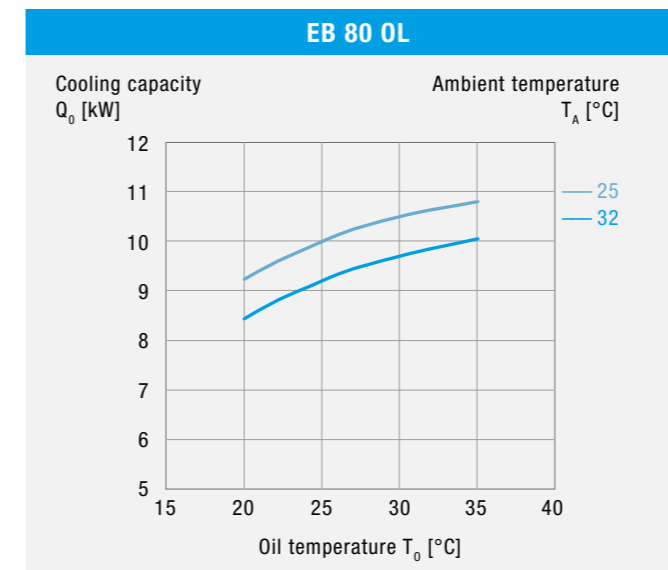
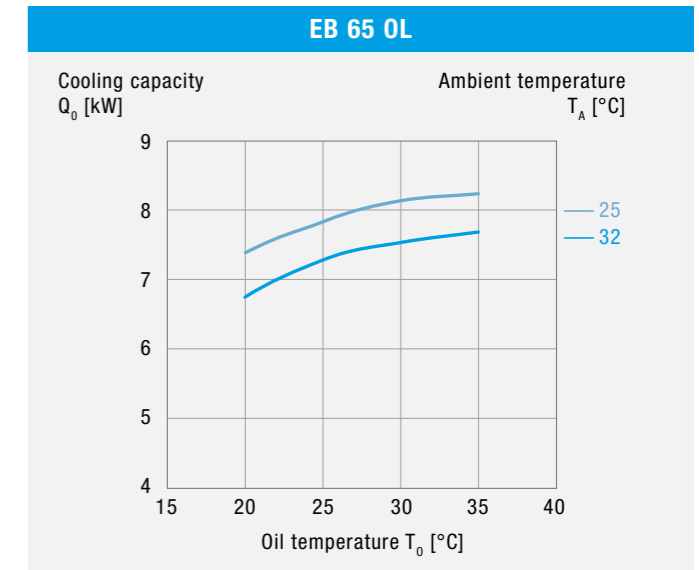
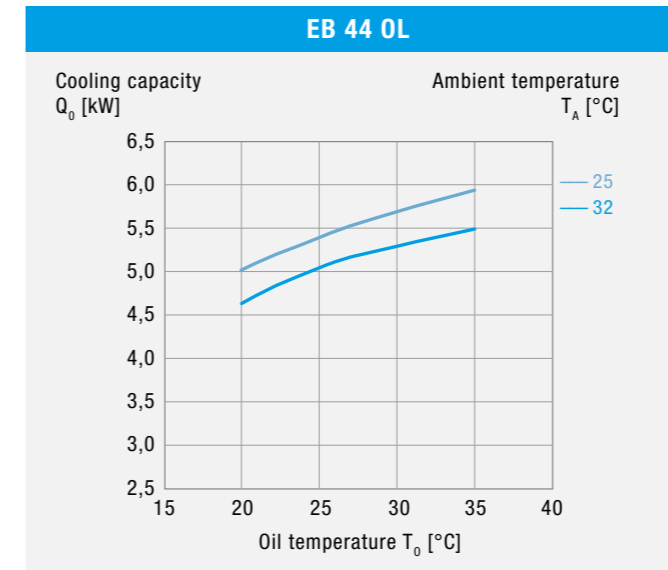

**EB 2.0 OL:** For a 40 °C ambient temperature you can expect capacity values shown for 32 °C to decrease by 20 %. For a 45 °C ambient temperature you can expect capacity values shown for 32 °C to decrease by 30 %.

**EB 2.0 OL:** For a 40 °C ambient temperature you can expect capacity values shown for 32 °C to decrease by 20 %. For a 45 °C ambient temperature you can expect capacity values shown for 32 °C to decrease by 30 %.

# Safe signaling.



## Flashing Lights, Sounders and Signal Towers.

Very few companies worldwide can comprehensively advise you in this area and supply you from one source the way that Pfannenberg can. We offer standard solutions with 10 year warranty as well as customised solutions.

Signaling devices from Pfannenberg can be used in the areas of industry, building technology, infrastructure projects, plant engineering, in the sector of renewable energy or on cranes and masts, and even in light art – e.g. in the illumination of the Eiffel Tower.

The devices are used for alerting, warning and to display the operating status of gas and fire alarms, start-up warning, emergency displays and for the general protection of persons. For safety-relevant applications, Pfannenberg supplies SIL and PL conform products.

On the following pages you will find a brief selection of our signaling devices.

**You can download or order your personal copy of the Pfannenberg Signaling Technology catalogue!** You can find the addresses at the end of the catalogue.

Protecting man, machine and the environment.

## PYRA® Series PY X-S-05 Flashing Lights

5 J (50 cd), 60 flashes per minute



**Connection**  
Simple electrical connection on the bottom of the casing.

**SSM**  
Optional with Soft Start Module for reduction of starting current.

**Safe and simple mounting**  
Installation options with external lugs or internal holes.

**Panel mounting**  
Suitable for panel mounting.

**IP 66**  
High protection system.

**Colours**  
Housing colours: red | grey | white.  
Lens colours: clear | white | yellow | amber | red | green | blue.

**IK08**  
Impact-proof lens.

**Modular design**  
Housing can be easily stacked side by side.

**Approvals**  
EN 54-23 | VdS | UL | EAC  
option: GL.



**!** Visual alerting on machines and in the building area under various ambient conditions.

## PATROL Series PA 1 | PA 5 | PA 10 | PA 20 Sounders

105 dB(A) | 107 dB(A) | 117 dB(A) | 122 dB(A)



**Connection**  
A single terminal block in the base supports all wiring connections.

**IK08**  
Impact-proof housing.

**Safe and simple mounting**  
Internal and external mounting capabilities.

**Mounting options**  
Panel mounting and surface mounting capabilities.

**Colours**  
Housing colours: red | grey | white.

**IP 66**  
Fastener holes are outside the sealing area – IP rating cannot be compromised.

**Approvals**  
EN 54-3 | VdS | UL | EAC | RS  
option: GL | MED | CNBOP.



**!** Audible alerting and alarm devices, also for very difficult applications in the sectors fire warning, gas and machine alerting.

## PYRA® Series PY X-M-05 | PY X-M-10 Flashing Lights

### PY X-MA-05 | PY X-MA-10 Flashing Light Sounders

5 J (56 cd) | 10 J (149 cd), adjustable flash rate | 100 dB(A)



**4 different flash rates**  
Choice of four different flash rates via DIP switch (0.1 | 0.5 | 0.75 | 1 Hz).

**IK08**  
Impact-proof lens.

**Panel mounting**  
Suitable for panel mounting.

**Safe and simple mounting**  
Installation options with external lugs or internal holes.

**Approvals**  
EN 54-23 | VdS | UL | EAC.

**reddot award 2015 winner**

**Multi-flashing light systems**  
Providing full synchronisation on multi-flashing light systems.

**Colours**  
Housing colours: red | grey | white.  
Lens colours: clear | white | yellow | amber | red | green | blue.

**IP 66**  
High protection system.

**Options**  
Integrated inrush current limitation and undervoltage detection.



## PATROL Series

PA X 1-05 | PA X 5-05 | PA X 10-10 | PA X 20-15

### Flashing Sounders

5 J (44 cd), 105 dB(A) | 5 J (47 cd), 107 dB(A) |  
10 J (129 cd), 117 dB(A) | 15 J (190 cd), 122 dB(A)

**Connection**

1-person assembly in rooms with high ceilings. Automatic contact of top part to bottom part when assembling.

**Safe and simple mounting**

Internal and external mounting capabilities.

**IK08**

Impact-proof.

**Mounting options**

Panel mounting and surface mounting capabilities.



**Colours**

Housing colours: red | grey | white.  
Lens colours: clear | white | yellow | amber | red | green | blue.

**IP 66**

Fastener holes are outside the sealing area – IP rating cannot be compromised.

**Economical**

All screw terminal clamps are redundant to support daisy-chaining of multiple sounders.

**!** Visual-audible signaling devices for loud and bright environments, also for indoors and outdoors.



## BR 35

Signal Towers Ø 35 mm  
3 W | 4 W

**Visual**

The light is amplified by the internal prisms of the impact-proof, heat-resistant and dust-proof polycarbonate lens and can be easily identified from all sides.

**Modular design**

Modular design with 6 different colour elements and 4 mounting methods offers endless combination possibilities.

**Mounting methods**

Stand mounting | plinth mounting | tube mounting | panel mounting.

**Applications**

For use in electronic production, in laboratories, in medical technology and in all other indoor applications.

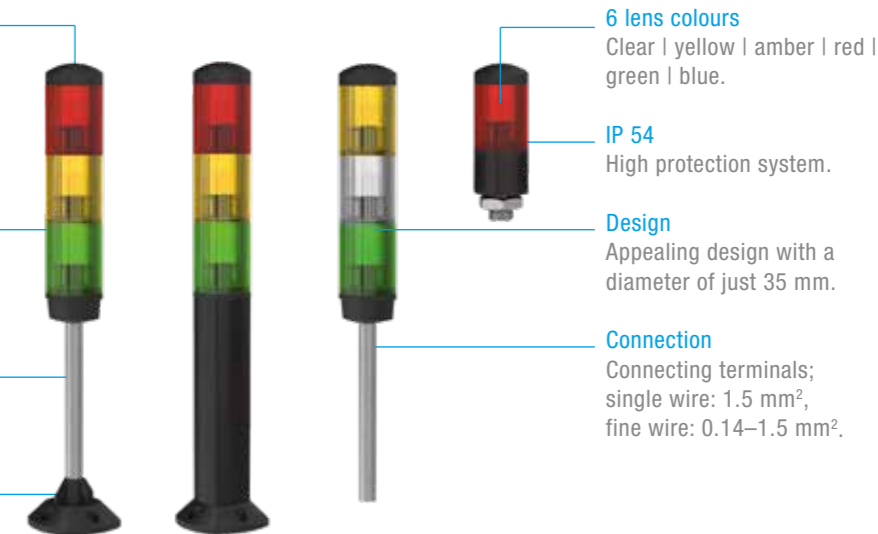

**6 lens colours**

Clear | yellow | amber | red | green | blue.

**IP 54**

High protection system.

**Design**

Appealing design with a diameter of just 35 mm.

**Connection**

Connecting terminals; single wire: 1.5 mm<sup>2</sup>, fine wire: 0.14–1.5 mm<sup>2</sup>.

**!** Machine lights in different designs to display various statuses and information.

## BR 50

Signal Towers Ø 54 mm  
5 W | 87 dB(A)

**Visual**

The light is amplified by the internal prisms of the impact-proof, heat-resistant and dust-proof polycarbonate lens and can be easily identified from all sides.

**Modules**

Continuous light | blinking light (1.5 Hz) | flashing light | sounder module 87 dB(A).

**Mounting methods**

Mounting stand | tube mounting | direct mounting.

**Applications**

Modular design with sturdy housing for all indoor and outdoor applications in tough conditions.



**IP 54**

High protection system (optionally IP 65).

**6 lens colours**

Clear | yellow | amber | red | green | blue.

**Easy handling**

Flexible building kit system guarantees easy handling.

**Variable**

Up to 5 modules with 6 lens colours can be combined as desired by simply plugging together, even retrospectively.



# SOLUTIONS

Our route to individual and cost-efficient thermal management solutions – the Pfannenberg Advantage™. In the framework of our four-level consultative approach, we analyse certain needs and accomplish specific solutions. Take a look at examples of our work for clients in a wide range of different applications and discover what we can – from developing customised solutions to successfully validating your own products.

# A results driven, 4 step process that begins and ends with the user.

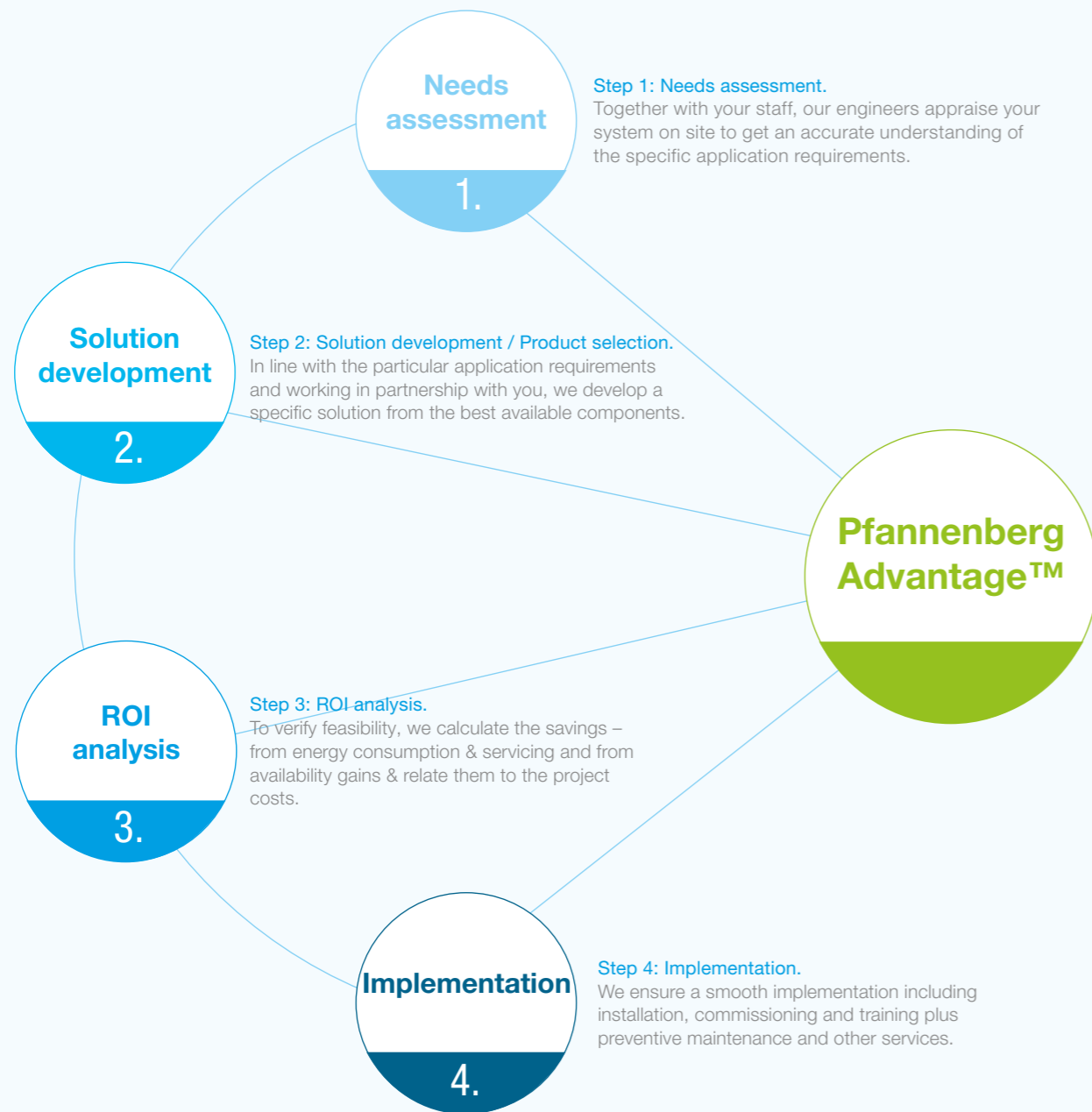

How we ensure that you obtain exactly what you need.

Our mission is to work with you to find the perfect solution for your thermal management needs – both economically and technically. To achieve this, we work with a unique consultative approach and first-class standard products, custom products, and solutions as well as wide-ranging engineering services.

We cover a broad spectrum of application fields with our standard products. However, if your needs go beyond, we are always capable of adapting our products to your specific requirements, developing completely new products, and optimising customised solutions. We can accelerate innovation development thanks to our knowledge of specific needs in various industrial applications.

With the Pfannenberg Advantage™ you benefit from our expertise – a solution addressing the entire factory, all machine requirements, and adding true value.

Protecting man, machine and the environment.

Trusted partner for R&D.  
Whenever you need us.



**Our R&D department offers the full range of services of an engineering practice:**

- Conception.
- Development of specifications and test plans (layout).
- Design.
- Flow simulation (CFD).
- Prototype construction.
- Validation of prototypes with regard to relevant requirements.
- Production of design and production documents.

Sharing competence – sums up our mission concerning collaboration with our clients. This is not merely a question of sharing expertise, but of dynamically fostering future innovation. We know what it takes to turn an initial idea into a finished product. And we have the resources to test the capability and potential of new ideas using prototypes. Benefit from our knowledge and technical facilities for your own development project.

**You have the idea. We help with the implementation.**

With our R&D service, we support in the development and testing of components in the fields of system thermal air conditioning, thermal management and signaling. For this, we can provide a complete range of services of a well-coordinated and experienced engineering team – suited to needs and cost-efficient.

**Outside expertise, in-house simplification.**

The benefits are apparent. Benefit from the extensive expertise of our specialist team without having to temporarily expand your own R&D services. Without fixed costs rising and without the need to engage in the associated personnel processes, you can continue to concentrate on your core business areas.

**Case study: Product development.**

**Client:** Manufacturer and fitter of multi-function housings in the telecommunications industry.

**Challenge:** The client lacks the resources to provide its customer with an electrical enclosure prototype with an active top-mounted ventilation within 4 weeks.

**Solution:** Our R&D team develops a precise specification and test plan with the client. After production of the prototype by the due date, it is tested to confirm that it meets the relevant requirements. Both prototype and test report are then sent to the client.

Following successful acceptance by the end customer, the design and manufacturing documents are also passed on. Pfannenberg builds the first 100 units, after which the client takes over the manufacturing.

Open for validation:  
Our test laboratories.



The quality of a product is apparent during its validation process. Our mission is to provide maximum quality; we subject our products to rigorous tests and check them thoroughly for compliance with the appropriate standards. To do so, we use the professional services of our own test laboratories, which we open to use for other companies.

**Tested and proven to be efficient.**

Many manufacturers use our facilities to test their products, with the main benefit being cost-efficiency. This saves them having to obtain and maintain their own laboratories, while still having access at any time to professional test equipment and the skilled staff to operate it.

**The economical route to reliable results.**

Together, we develop a precise test plan based on the relevant norms and standards, organise all the necessary tests, and deliver a comprehensive test report at the end. Our laboratories enable you to cost-effectively carry out diverse activities:

- Test under all relevant environmental conditions.
- Test functional efficiency and reliability.
- Test conformity with applicable directives.
- Test at different temperatures.

**Select from extensive test procedures.**

We offer concept creation, preparation and execution of:

- Environmental simulations in the climatic chamber.
- Thermographic images.
- Protection system tests (IP protection).
- Transport and vibration tests.
- Air quantity and light intensity measurements.
- EMC tests.
- Determination of noise emissions.
- Flow simulation (CFD).

**Case study: Product validation.**

**Client:** Technology leader in the manufacturing of laser marking systems.

**Challenge:** The client has developed a new controller for their laser marking systems, while lacking the resources and equipment to be able to test it for conformity with the necessary design criteria. In particular, checking the IP protection system (IP 54) is crucial to ensure that it does not fail the tests later in the accredited (and costly) test laboratory.

**Solution:** Together we develop the precise test plan. In accordance with the required norms and standards, tests are performed in our dust chamber (IP 5x), and with the spray arch (IP 4x), and weak points are analysed and improved. Finally, the client has tests performed in an accredited laboratory, with a successful outcome.

## 100 % reliability for the high-precision industry.



A Swiss industrial enterprise operating globally develops processing centres for the precision boring and milling of high-precision components. For smooth-running operation, perfect thermal management for the control electronics is crucial. The production chambers are designed to take up very little space and have relatively tall electrical enclosures, which fosters the development of partial heat pockets. Thermal management with compact cooling units proved to be unreliable so far because of the problems with condensate.

### Application requirement.

Space-saving thermal management solution to keep the manufacturing centre space requirement compact. Very good air circulation to prevent heat pockets. Absolutely reliable protection against condensate and assurance of top-level machine availability – even under difficult environmental conditions.

### The Pfannenberg solution.

A revolutionary innovation due to its original and patented condensate management, the DTT series top-mounted cooling units meet the requirement for maximum reliability, minimum space take up, and 100 % protection against condensate.

The top-mounted cooling units provide unique, four-fold condensate protection:

1. No cold bridge to the electrical enclosure cover.
2. No overflow of condensate into the electrical enclosure.
3. No condensate buildup in the airflow.
4. No air hoses, which are otherwise at risk of condensation.

Further benefits:

- High-volume air delivery via the integrated nozzles to accelerate cold air movement right down to the bottom of the cabinet.
- Filter media for any area (contaminated ambient air).
- Controller with energy-saving mode to maximise energy-efficiency (optional feature).

### Implementation.

Switching to the DTT top-mounted cooling units successfully delivered maximum possible machine availability. The units are compatible with all makes of electrical enclosures and are available in 3 sizes and 6 performance levels. As for their cUR approval and versions with 230 V and 400 V voltages, the processing centres can be used around the world.



In focus:  
**System characteristics**

## Bypass solution for chillers in the food industry.



An Italian manufacturer of pasta making machines regularly complains of problems in the production process. Faulty pumps in the cooling system obstruct the flow of fresh water during pasta production. This leads to downtime, additional repair, and substantial costs.

### Application requirements.

Reliable flow of cooled fresh water for the pasta extruders, assurance of consistently fault-free functionality, the necessity of hydraulic bypasses, and a guarantee of reliability.

### The Pfannenberg solution.

Analysis conducted with the client identifies the most suitable solution: The use of hydraulic bypasses. Type CC 6301 chillers, which are immediately available, are a standard option and exactly meet the specific requirements.

Special features of the chillers are:

- Great variety of standard options; e.g. integrated hydraulic bypass, integrated flow switches, aluminium air filters etc.
- Separate cooling and hydraulic circuits.
- Optimum long-term stability through the use of high-quality components.
- Liquid cooling with water, water/glycol mixtures and low-viscosity oils.
- Programmable control module enabling small hysteresis of the cooling medium temperature.
- Steel housing with thick powder coating.

### Implementation.

A total of 14 CC 6301 chillers with integrated hydraulic bypass were installed. The robust stand-alone units are UL certified and guarantee maximum machine availability and maximum MTTF\*. Standardised components and a sophisticated plug&play concept also minimise repair costs and downtimes.

\*\*MTTF: Mean Time To Failures.



In focus:  
**Process characteristics**

## Cooling lubricant provision: maximum efficiency on a small budget.



### Application requirement.

Provision of four work benches in total with cooling lubricants, reliable cooling from 3 oil tanks (capacities of 200, 300 and 800 litres) where 1 oil tank is already in place and connected to a chiller. Solution with maximum possible cost-efficiency.

### The Pfannenberg solution.

Taking budgetary restrictions into account and making maximum use of the on-site circumstances, a customised, economic system solution was developed.

A central component is a chiller system dimensioned to meet the requirements and is located outside the building to enable better accessibility to main water. 3 water/oil heat exchangers were implemented, each used on one of the oil tanks, to complete the solution.

Special features of the system solution are:

- A robust EB 190 WT chiller which can also be located outside if necessary.
- 3 maintenance-free water/oil heat exchangers.
- Maximum safety, energy and cost-efficiency.
- Optimal long-term stability and reliability (maximum MTF\*).
- Unsurpassed ease of servicing (minimum MTTR\*\*).

### Implementation.

The company benefits from an individual solution which proves to be very economical both in terms of its acquisition and in its daily use. To increase cost-efficiency even more, the chiller used so far was integrated into another application within the factory.

\*MTF: Mean Time To Failures.

\*\*MTTR: Mean Time To Repair.



A world leading manufacturer of hydraulic components and systems seeks a smart and cost-effective solution for a special production application. An existing system consisting of an oil tank and chiller system is to be expanded by 2 oil tanks. For budgetary reasons, acquiring 2 new chillers is ruled out.

**In focus:**  
**Complete system solution**

## Restoring machine uptime for a track builder.



### Application requirement.

Reliable oil cooling of a high performance track drilling unit. Safeguarding the machine uptime also at lunchtime and in the afternoon when the production hall is heated by sunrays.

### The Pfannenberg solution.

An analysis carried out on location with the customer revealed that the cooling capacity of the two chillers no longer corresponded with the current requirements. In order to counter the increased performance of the track drilling unit with an appropriate cooling performance, the cooling system had to be redesigned.

Taking the temporarily high ambient temperatures in the production hall into account, the clear solution was a high performance chiller type EB 90. This unit has an integrated control module which provides a precise temperature control of the cooling medium.

The solution excels due to:

- Separate cooling and hydraulic circuits.
- Control module to program small hysteresis of the oil temperature.
- Use at ambient temperatures of up to +40 °C.
- Sturdy steel housing with thick powder coating.

### Implementation.

As a result of our experts' on site analysis, the company saved a costly and insufficient repair of the old chiller systems. Using a new solution that is tailor-made to meet current needs ensures the desired machine uptime – also in the hot lunchtime period. A supplementary maintenance contract was made, ensuring the optimal functionality in the long term.



In the factory of a company which specialises in the manufacturing of tracks and rail components, limitations in the production occurred. The operation of a track drilling unit with improved performance leads to a reoccurring overload of their two chillers which are connected, causing downtime for the machines.

**In focus:**  
**System characteristics**

## A desert state: Water cooling under extreme conditions.

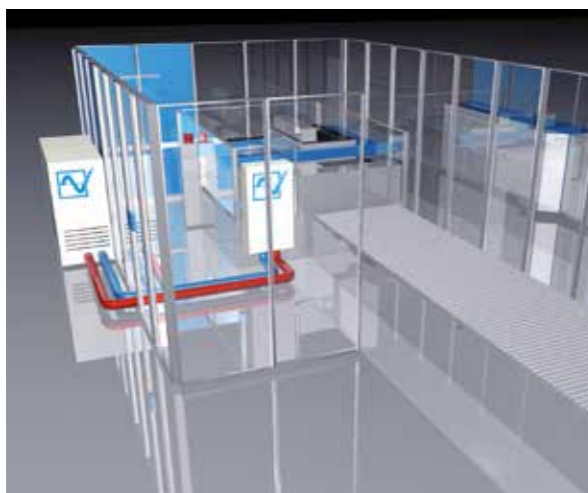

A German manufacturer is setting up an industrial laundry system for the airport in an Arab capital. Inside the system, the prevailing temperatures reach 60 °C. Both the temperature and the air humidity can get increasingly higher when the washing machine drums are opened. The thermal management of the electrical enclosure is using cooling units that are counterproductive because its exhaust air would heat the area up even more. This could force the premature failure of electronic components and put the smooth running of the system at risk.

### Application requirement.

Thermal management of the electrical enclosures without any additional heating of the immediate ambient air. A high level of system availability under testing temperature and air humidity conditions.

### The Pfannenberg solution.

The concept which is geared to the system's needs, relies on water cooling. High-grade temperature resistant air/water heat exchangers work independently of ambient air quality and do not generate exhaust air heat. A design perfectly adapted to the application, combines 3 air/water heat exchangers and a chiller to make an optimum system solution.

Special features of the system solution are:

- Maintenance-free **ECOOL** air/water heat exchanger, type PWS 6501 and PWS 6102 (+1 °C to +70 °C, protection system up to IP 65).
- Chiller, type EB 60 WT with the option for an outside location (-20 °C to +40 °C, protection system IP 54).
- Maximum safety, energy and cost-efficiency.
- Optimum long-term stability and reliability (maximum MTTF\*).
- Unsurpassed ease of servicing (minimum MTTR\*\*).

### Implementation.

As a special feature to meet the requirements, a chiller suitable for outdoor installation was selected. Placed outside of the laundry, it supplies the air/water heat exchangers located in the laundry and significantly increases machine availability because of the constant air supply temperature.

\*MTTF: Mean Time To Failures  
\*\*MTTR: Mean Time To Repair

## Reliable operation of a severely soiled packaging system.



The production area of a company producing high-quality construction and insulation materials from wood fibre experiences recurrent system failures and operating downtimes. The severe soiling from wood dust and rust particles from diesel powered fork lift trucks and lorries overpowers the thermal management solution using conventional point-of-entry filters and top-mounted fans and makes it necessary to retool the switching system.

### Application requirement.

Smooth-running production operation and reliable machine availability despite severe air contamination from wood dust and exhaust gas. Energy and cost-efficient solution with major ease of servicing.

### The Pfannenberg solution.

As a first step, all the switching systems were wet cleaned, both inside and outside. To rule out any repeat soiling, the top-mounted fan combination was replaced by partially recessed **ECOOL** cooling units (DTI 6301 model).

Special features of the cooling units are:

- Uniquely high energy-efficiency rating (EER).
- Significant energy savings / operating cost reduction.
- Condenser with wide fin spacing for highly effective protection against contaminated ambient air.
- Large distances between intake and exhaust vents (to eliminate hot spots).
- Perfect ease of servicing.
- New service interface for easy retrieval of parameter settings / history (Pfannenberg **ECOOL**-Plant software necessary).
- Optional filter can be retrofitted in a few seconds.
- Energy-saving mode in the Multi Controller integrated as standard.

### Implementation.

Use of the new **ECOOL** DTI 6301 cooling units led to reliable system operation and to the highest possible machine availability. The environmental and cost balance sheet demonstrates considerable reductions with regards to energy costs and CO<sub>2</sub> emissions, as well as service and repair times.



In focus:  
**Complete system solution**



In focus:  
**Dirt, dust**

## Operational safety for the longest railway tunnel in the world.



### Application requirement.

Compliance with the IP 65 protection system even under extreme air pressure fluctuations caused by passing trains. Tolerance to extreme temperature differences and resistance to dust and humidity. Ensuring maximum availability during continuous use.

### The Pfannenberg solution.

Working in close cooperation with the client and the electrical enclosure manufacturer, we developed a new series of cooling units: the DTGT 9041 and DTGT 9541 models designed specifically for use in tunnels.

The cooling units have:

- A specially developed pressure element with integrated electric circuit.
- A new generation of controllers with Ethernet protocol for central function monitoring.
- An intelligent control configuration to maximise energy-efficiency.
- A guaranteed operating period of 10 years with defined maintenance measures for short MTTR\*.

### Implementation.

Approximately 980 DTGT 9041 and DTGT 9541 cooling units were installed in the region of 176 cross-cuts along the course of the tunnel. The cooling units work perfectly with air pressure fluctuations of up to  $\pm 10$  kPa, temperature differences of  $-20$  °C to  $+40$  °C and humidity levels of up to 100 %. A central control unit monitors the current temperature in the electrical enclosures and the operating time of the most important components. This allows planning maintenance work in advance in order to eliminate system failures and to ensure a high level of system availability.

\*MTTR: Mean Time To Repair



Development of a thermal management concept for electrical enclosures in the 57 km long Gotthard base tunnel (Switzerland). Maximum route capacity: over 300 goods and passenger trains per day at speeds of 160 km/h to 250 km/h, at three-minute intervals during the day.

**In focus:**  
**Vibration, shock, temperature**

## Thermal management under extreme ambient conditions.



### Application requirement.

Tolerance against extreme environmental conditions and fluctuations in terms of temperature, humidity, and air composition. Resistance against shock and vibration occurring for reasons including the extreme impacts affecting the rotors. High-level availability in thermal borderline cases.

### The Pfannenberg solution.

To meet these specific requirements, a series of robust high-performance fan heaters was developed: The compact FLH-T models.

The fan heaters have:

- An integrated thermostat (with optional hygrostat).
- High heating outputs from 250 W to 1,000 W.
- A storage and operating temperature of  $-40$  °C to  $+70$  °C.
- A uniform size to enable problem-free fitting depending on the need for thermal management.
- Ball bearings (instead of conventional sleeve bearings) to increase life expectancy, particularly at high temperatures.



### Implementation.

In both the wind energy industry and in the field of telecommunications, the FLH-T models have gained a leading position. As the only unit available on the global market today, the product meets the demands of the oscillation and shock tests according to DIN EN 60068-2-6 | 60068-2-27 | 60068-2-29 (railway applications – goods train gear). The FLH-T series is certified for the American, Canadian and German markets (UR, CE).

A thermal management solution resistant to vibrations has to be developed for wind power station manufacturers operating globally. The control technology of the rotors is exposed to extreme weathering and temperature fluctuations at their various locations (desert, mountains, offshore). The trend towards ever larger rotors also places the rotor blades under increasing stress levels.

**In focus:**  
**Temperature, shock, vibration**

A photograph of two men in an industrial setting. The man on the right is wearing a high-visibility yellow safety vest over a dark t-shirt and is looking down at a tablet computer he is holding. The man on the left is wearing a brown shirt and is pointing at the tablet with his right hand. They are standing in front of a large piece of industrial machinery with blue metal frames. A large, semi-transparent blue circle is overlaid on the left side of the image, partially obscuring the background and the text.

# SERVICES

Comprehensive advice and worldwide support – with our services, we provide you with all the necessary service to secure your machines' uptime and also to optimise their energy efficiency – from the planning of individual thermal management solutions, to comprehensive plant audits and maintenance. Our service is not limited to Pfannenberg products, but also includes the units of all other manufacturers.

# Advised better.



Operational safety right from the start:  
Customised for maximum machine availability.



Choose from our modular additional services.  
And put a hook to it!

**Installation and assembly on site**

We take care of piping and on-schedule installation for you: for new installations and rebuilding measures/retrofit.

**Professional commissioning**

Only a perfect start avoids malfunctions and expensive machine damage.

**Leak tests (F-gases)**

Mission: Detect the smallest leaks, stop refrigerant loss immediately. Your advantage: With us, you at once comply with statutory inspection obligations as an operator.

**Retrofits & modernisations**

Whether you need to change the refrigerant for old devices or optimise your cooling solution, we make you fit for the future.

**Technical trainings**

We make your commissioning and maintenance personnel fit for the essentials.

**Backup devices planning**

Increase your flexibility in day-to-day service: especially if you have to take care of a large stock of equipment.

**Preventative maintenance**

Preventive against disturbances and standstills. We actively maintain your entire equipment inventory – manufacturer-independent.

**Filter media for every area**

The right filter protects against dust, air containing oil or aerosols and thus against overheating. Only the original protects you against warranty forfeiture.

**Recommended spare parts**

You should always have these original parts ready: because their availability makes all the difference when speed counts.



**Repair service**

Whether in the Service Center against a cost estimate or directly on site in an emergency: We repair your equipment – reliably and manufacturer-independently.

**Warranty extension**

Get a secure calculation base for a small surcharge.



Please contact us:  
[service@pfannenberg.com](mailto:service@pfannenberg.com)

## Reliability from the beginning: Commissioning and maintenance.

The reliability of your plants depends on the thermal management devices and cooling solutions functioning constantly. In order to guarantee this, we are there for you at any time. Worldwide.

### Commissioning. The perfect start.

There is no substitute for professional commissioning. It prevents malfunctions and damage to machines. This applies to the complex configuration of cold water aggregates in particular.

Our service technicians support you in:

- Conversion, expansion or dislocation of your existing cooling units.
- Questions on technical support for your cooling applications.
- Commissioning new devices in your production plants.
- Handling and completing the organisation's commissioning.

Commissioning includes the following:

- Checking the coolant piping system at cold water plants for professional dimensioning and designing prior to the piping assembly.
- Connection of the cold water aggregates to the coolant piping system.
- Professional installation of devices to the power supply network.
- Filling the cold water aggregates and the connected piping system with the coolant, such as water, salt water, etc.
- Test operation and commissioning of the complete plant system.
- Measuring and documenting all relevant technical data.
- System transfer to the operator.
- Creating a system transfer log.

### Maintenance. The perfect prevention.

The highest quality components are always exposed to unavoidable wear and tear. That's why we recommend checking the optimum functionality of the units and components at regular intervals.

Depending on the application, maintenance once or twice a year is sufficient to achieve increased reliability and a significantly improved machine uptime.

### Increased reliability and more.

You benefit in many ways from our maintenance service. Our trained technicians come to your plant and can review current measurement and control software, to check unit functions and if necessary make appropriate adjustments. Additionally, they support you with cleaning the device, inspections and further maintenance measures for the optimisation of your plant and your production.



Maintenance contracts can be combined with a warranty extension. Our service staff and you develop a model adjusted to your individual needs.

Maintenance includes:

- Checking the essential aggregate functions.
- Checking and exchanging wear and tear parts.
- Carrying out required cleaning.
- Readjusting control and regulation modules.
- Providing tools and measuring devices.
- Creating a maintenance log and specification of the parts which might be needed for maintenance work.

## The most expensive machine is one that is idle.

A benefit of our worldwide service network is its ability to react. If a cooling system loses its efficiency or threatens to lose it, we can be with you promptly.

### Repairs that take less time.

Our repair service guarantees an error diagnosis as quickly as possible and on-site repairs. This has several advantages: it means units do not have to be transported back and forth which is time consuming and expensive. And it reduces downtime to a minimum.

Of course, you can also use our repair service when the cooling systems in question are from another manufacturer.

Our service includes the following:

- Checking defect units for causes of failure.
- Error diagnosis.
- Creating repair cost estimates.
- Repairing units on site.
- Processing unit returns.

### The tests which provide more security.

In order to guarantee the proper function of chillers and to prevent machine downtime effectively, we carry out professional leak tests on your systems in compliance with statutory requirements.

Our service technicians are certified for this work as per EU Regulation No. 2015/2067.

Services:

- Check cooling systems for tightness and possible damage due to vibrations, corrosion or ageing fatigue by qualified staff. Documentation in respect of relevant regulations.
- Consideration of legal regulations for operators; inspection interval based on CO<sub>2</sub> equivalent of the plant in accordance with EU Regulation No. 517/2014.



Benefits:

- Preventing machine downtime due to loss of refrigerant.
- Compliance with legal requirements.
- Can be combined with device maintenance.
- Secured availability of equipment.
- Timely testing of alternative refrigerants before 1.1.2020.



Use the PfannenberG F-gas calculator to check whether the stricter legal regulations are relevant for your plant.

To do this, enter the webcode **2977** in the search window on [pfannenberG.com](http://pfannenberG.com).

## Service trainings: Practical knowledge for employees.

The security of your plant is not only guaranteed by technology. The fact that your staff is able to have an eye on the processes, having the ability and knowledge to react correctly in time (if needed) is imperative for the smooth running of the plant. Our trainings put your staff in the position to learn the practical knowledge to be able to act accordingly.

### Expert tips – directly applied.

How do thermal management circuits work? How do the systems used in the plant work? How do you detect faults and how are they resolved? In our trainings, experienced technicians give answers. Your staff extends their knowledge in the area of cooling technology and learns how to cope with failures in concrete scenarios.

The effect: Your staff can not only recognise failures more quickly, but they also know how to help themselves.

By making the right decisions regarding the repair of faults for the continuation of production, they ensure a more economical and smooth operation of the systems.

We offer you this training on site or at our facility.

As standard, our service training comprises the following:

- General information on the cooling technology (circuit, components, functional processes).
- The cooling unit – in direct relationship to the customer application.
- Commissioning a cooling unit and the customer systems.
- Fault simulation, fault detection.
- Fault correction measures during commissioning.
- Information about establishing contact in event of a fault.
- Information about the work processes and the document stream in the event of a problem.



## When it matters: Only original spare parts.

There is only one substitute for the high quality of our components: our original parts. With these, you benefit from our many years' experience in the development and manufacturing of cooling units for electrical enclosures, filterfans, chillers and signaling devices.

### Perfect functionality – guaranteed.

Our original parts go through comprehensive tests and fulfil the highest quality standards. They are optimally adapted to our units and not only offer the desired functionality but also contain the guarantee for the respective whole product. Additionally, every improvement within the framework of our product development is of direct value to you.

Durability and an excellent price-performance-ratio make our original parts particularly economical.

### Recommended spare parts for your equipment.

You should always have the most frequently required spare and wear parts at hand. The availability of these recommended spare parts makes all the difference when speed counts. In the best case, these few original parts are stored directly by the equipment operator. Only then the hardware is immediately available and any downtimes are reduced to a minimum.

Our recommended spare parts include, depending on the product family, among others:

- Fans.
- Electronic components.
- Compressors.
- Expansion valves.
- Pressure switch.

The advantages of our recommended spare parts:

- In the event of failure, the immediate availability of the spare parts that are needed most frequently.
- Downtime is reduced to a minimum or longer downtime is avoided.
- Many spare parts can be installed independently by a trained electrician (without interfering with the refrigeration circuit).

Only with our recommended original parts from Pfannenberg can you be sure that ...

- they are the right parts.
- they fit.
- they are in stock.
- they can be quickly available on site.
- you don't lose any valuable time.
- the proper functionality is guaranteed.
- the guarantee for your whole unit remains intact.



A large industrial pipe and machinery against a sunset background. The scene is dominated by a large, light-colored industrial pipe that runs horizontally across the middle of the frame. To the right, a complex piece of machinery, possibly a pump or motor, is visible, featuring various panels and components. The background shows a vast, flat landscape under a clear sky with a bright sun setting on the horizon, creating a warm, golden glow. A solid blue vertical bar is positioned on the left side of the image, partially overlapping the pipe and machinery.

# INDUSTRIES

We are involved in many different industry sectors – worldwide. Our knowledge of supply chains and specific demands makes us the most sought-after partner of leading companies in industries such as automotive, machine and plant construction, energy, food and beverage, and infrastructure.

# Do you love innovation?



We do.

Industries on the move need a global partner. We are that partner. Our very first innovation, the world's first filterfan, resulted from the close collaboration with our customers. Today, we are a world leading company and support clients on all continents. As consultants, problem solvers, and pioneers – in the following areas:

**Automotive.** We ensure a high level of availability, safety and efficiency along the whole process chain – for manufacturers and suppliers.

**Energy.** Thermal management and signaling solutions for manufacturers of wind power turbines and their suppliers. We also create innovations to support the construction of intelligent power networks (smart grids).

**Food & Beverage.** We offer a broad spectrum of components and solutions for filling and packaging machines, process lines, brewing technology as well as baking and meat-processing machines, to name a few.

**Infrastructure.** Products and integrated solutions for particular applications including the construction sector (buildings, roads, tunnels), in transportation (airports, shipping and cranes) and in the waste water industries.

**and many others.**

Protecting man, machine and the environment.

## Automotive Industry: Full throttle for production security.

The expectations regarding the performance of production lines have increased. Longer life-cycles mean higher requirements for machine and component uptime at the same costs and energy efficiency. We support manufacturers and suppliers along the whole supply chain from the press plant to quality control.

### Solutions shaken by nothing.

Manufacturing facilities that produce engines, gearboxes, axles, or shafts are exposed to extreme stresses. Knowing this, we developed components which are designed and constructed for these harsh environments. For example, our air/water heat exchangers which protect the control units of machines from overheating at high ambient temperatures or our compact chillers for the cooling of spindles, engines, hydraulics and lubricants.

All production lines are accompanied by signaling devices which display machine statuses and alert operators about danger. In large plants, this is achieved by our all-round flashing lights from the PMF series and our DS series sounders, which with 114 dB(A), assert themselves even against the loudest milling machines.



### Complementary components.

Our air/water heat exchangers from the **ECOOL** series are the first choice for secure thermal management in the most severe ambient conditions. They have a resistant housing made out of robust sheet steel, resistant to heat and dirt, and are maintenance free.



Air/water heat exchanger

CCE chiller series

### Air/water heat exchanger

- Cools regardless of the type of environment.
- Maintenance free.
- Optional water connection from on top.

### CC chiller series

- Compact design – fits in small space in already restricted production facilities.
- Large tank openings for quick maintenance.
- Steel housing with thick powder coating for tough industrial environments.

## Customised for the manufacturing industry.

Doors and bumpers are shaped by large presses, robots carry out delicate painting and mounting work – as different as the machines, the work steps and the respective spatial conditions are, so different are the solutions to prevent downtime.

### More operating space.

In product, every square meter of the facility is valuable space. Our DTT top mounted cooling units are perfect for facilities where space is limited and escape routes need to be clear. Thanks to patented condensate management, the DTT series guarantees 100 % protection against condensation and ensures protection of electrical technology.



DTT top-mounted cooling units

Air/air heat exchanger

### DTT top-mounted cooling units

- Limited space required.
- Escape routes are kept clear.
- 100 % protection from condensation.

### Air/air heat exchanger

- 6 performance classes from 20–100 W/K in 3 installation sizes.
- Long airflow for secure circulation of the electrical enclosures.
- Integrated thermostat to regulate temperatures.

### The proper solution to every requirement.

Assembly and conveyor lines are typically set up in an environment which offers proper airflow. If the use of filterfans is not an option, our air/air heat exchangers from the **ECOOL** series would be the proper solution. In order to react to the spatial demands, these devices allow side mounting or also partially recessed mounting.

Protecting employees in areas, such as where the presses are located, SIL/PL complaint signaling devices are the solution. When the air is contaminated with solvents, the ATEX models are appropriate. In final inspection instances, our heaters protect the control units against the formation of condensation in the units.



## Transforming technology for the future.

OEMs know: Looking towards the future, engineering processes will demand new and more technology. What is needed is an overall optimisation – with solutions that combine maximum performance, with environmental friendliness and maximum cost efficiency. Against this outlook, our **ECOOL** technology sets a new standard.

### **ECOOL is the most efficient solution.**

Thanks to specially developed components and intelligent control electronics, **ECOOL** cooling units achieve an unmatched Energy Efficiency Ratio (EER). In terms of energy costs, this generates annual savings of over 35 %.

The **ECOOL** series also set records in terms of ease of assembly and maintenance – which leads to more cost benefits. When it comes to system solutions, the combination of **ECOOL** air/water heat exchanger and chillers would make the best solution.

### **Security planning for system integrators.**

Acting as a link between automotive manufacturers and system integrators, we know what is important in the formation of specific solutions: flexibility and compatibility. This is why our **ECOOL** cooling units, air/air and air/water heat exchangers, and active cooling units are cut-out designed.

### **Flexibility at any time.**

In the project planning phase, the specific thermal management requirements prevailing at the various production sites and the expected thermal losses of the electronic components are not fully available at this stage. Thanks to the various cooling technologies and performance variants, the **ECOOL** series offers complete planning freedom so that the ideal unit can be selected.

Our free Pfannenbergs Sizing Software (PSS) supports you at the design and project planning stage. Furthermore, we offer a simple and free link to our product macros for EPLAN and Zuken. You can find these in our download area at [www.pfannenbergs.com](http://www.pfannenbergs.com).

### **The benefits of ECOOL technology.**

#### Energy and cost efficiency:

- More than 35 % lower energy costs.
- Up to 48 % lower CO<sub>2</sub> emissions.
- Up to 80 % shorter service and repair times.

#### Design:

- Cooling units for side mounting, partially recessed side mounting and top mounting.
- Robust sheet steel; option for various colours to suit the look of the machines/systems.
- Matching all designs of electrical enclosures.

#### Flexibility:

- Increased planning and investment security through cut-out compatibility.
- 3 cooling technologies: active cooling units, air/air heat exchangers, air/water heat exchangers.
- Rapid and cost-effective system adjustment.

#### Technology:

- Integrated condensate management.
- Long air ducting to eliminate hot spots.
- Multi-voltage units.

## Specialists in numerous areas: Machine construction, chemicals, oil, gas, wood... and service.

Our components and solutions provide maximum machine availability in many industries. However, our expertise and reliability are not restricted to our clients. As a leading manufacturer, we offer full services for all makes of chillers and electrical enclosure cooling units.

### **The best protection against downtimes: Full Service.**

Whether it is in the explosive atmosphere of petrochemical plants or in the dusty production lines in the wood-processing industry: chillers, filterfans and cooling units are exposed to harsh environmental conditions. Even more importantly, is the reliability of operation at all times. Even small set up errors can cause considerable damage – qualified service protects against this and avoids potential consequential costs.

### **Safety: Switching system audits.**

Our service ensures safety right from the start. An examination of existing thermal management solutions and electrical enclosure configurations in a system audit can reveal the potential for major savings by switching. In many cases, energy-efficiency can be increased significantly by converting to an alternative cooling concept. Our specially trained technicians both install the pipework for the chilling water network and adapt the switching system mechanically and electrically.

### **Constant availability.**

In order to continuously protect your systems against failures, our full service includes: Expert commissioning – plus acceptance report, maintenance work – plus preventive action against unplanned system downtimes, rapid spare part shipments, and regular leakage tests.



## Full line solutions for the food and beverage industry.

Technology used in food production faces many challenges. With specific cooling solutions and sophisticated signaling technology, we ensure quality and durable machines in highly dynamic processes with rapid cycle times – from raw material processing through manufacturing and quality control to packaging.



### Maximum performance and energy-efficient.

Whether in a grain mill or a beverage bottling line – high-tech production lines often run in continuous operation. Our **ECOOL** cooling units and filterfans provide the ideal solution cooling of electronic components and keeping particles (dust, flour, water) from entering enclosures. They combine maximum performance with unmatched energy and cost efficiency, and ensure continuing operations.

### Built for harsh environments.

Acidic vapours occurring when canning fruit and vegetables, flammable hydrogen sulfide during meat processing, flour and condensation that are often present in bakeries – sensitive control technology needs to be protected from many factors.

With IP 56 protection, our maintenance-free series 3 cooling units satisfy the toughest environments. They are available with a corrosion protected hood in brushed stainless steel with epoxy-coated copper pipes and condensers; they offer reliable protection against alkaline solutions and acids. As a high-temperature model, they are also suitable for use in hot baking environments with temperatures ranging up to +60 °C.

In the meat processing industry, compact and robust Rack series chillers are responsible for cooling mixing chambers. They provide a space-saving stand-alone solution for the cold water supply.

### Customised solutions.

In predominantly demanding testing areas, our maintenance-free **ECOOL** air/water heat exchangers and EB series chillers are both cost-effective system solutions which operate independently of the ambient air.



Cooling unit series 3

Chiller Rack series

Chiller EB series

Air/water heat exchanger ECOOL series

Cooling unit ECOOL series

## Patented designs for more reliable operation.

The high performance of our products doesn't come out of the blue. A series of patents underscores our quality advantage, giving our customers an extra safety-plus; for example, our 4th generation filterfans or top-mounted DTT series cooling units.



### “Trust the Original”: Inventor of the filterfans.

A variety of different conveyor belts use small electrical enclosures cooled by ambient air. Here, our series 4.0 **ECOOL** filterfans provide a safe and economic solution.

With flow-optimised fins and rotor blades, they enable maximum airflow with minimum energy consumption. Thanks to their patented fluted filter mat, they achieve IP 55 protection and a 300 % longer product life, which reduces operating and maintenance costs.

Combined with a thermostat, their efficiency is increased and only operates when active cooling is needed. Fitted with a weather-proof hood, they are also unaffected by high-pressure cleaners.

### Top-mounted cooling units with 100 % protection from condensate.

Where space is limited, the innovative top mounted DTT series cooling units are the perfect solution. They fit all makes of electrical enclosures and feature a unique patented condensate management system, which completely protects the control electronics inside the electrical enclosures from condensate.

The units come in three sizes, 6 performance levels, and a stainless steel finish. Different optional filter media make them suitable for use in severely dusty or aerosol contaminated environments.

Through their use of powerful, lightweight components and the energy-saving switch mode (when using the optional multi-controller), the top-mounted DTT series cooling units provide unmatched energy efficiency.



ECOOL Filterfan 4.0

Top-mounted cooling unit DTT series

## Continuous excellence.

Rapid-cycle sequences are a major feature in the manufacturing and packaging of food and beverage products. Our specific components and solutions for signaling, alerting and thermal management support the production processes with outstanding performance levels.

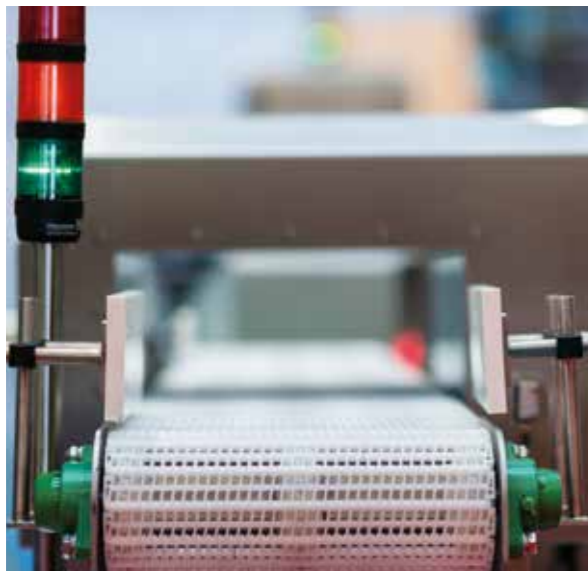

### Modern and innovative signaling technology.

Signaling technology is faced with a variety of different challenges running from the high operating speeds of different systems, various conveyor belts and production steps, to high background noise levels.

Status displays must give a permanent overview of machine and line statuses to optimise response times and minimise expensive downtimes.

Warning lights and alarm devices must signal hazards, risks and technical faults promptly in order to ensure system safety and reduce risks.

Against this background, combinations of audible and visual signaling devices reliably provide warnings and alarms even when loud conveyor belts are

running to capacity. For example, our BR 50 signal tower: modular in construction – it signals the particular conditions and hazardous situations using a continuous light, flashing light, blinking light or sound. Via an AS-i module it can also be integrated into AS-i networks.

### Reliable cooling performance.

Nearly all products in the food sector are packaged by means of special packaging machines. In the field of primary packaging – ultramodern tubular bag packaging and shrink wrap machines are used, which enable enormous throughput levels.

To achieve maximum availability of the packaging lines, series 9 cooling units are responsible for cooling sophisticated control electronics.

The cooling units are available with a stainless steel hood and are suitable for space-saving partially recessed door, side mounting and the classical door, or side mounted versions. Because of the large distances between the intake and exhaust vents, they incorporate long ducting which ensures a reliable flow of air for the electrical enclosures – which eliminates the formation of hot spots.



Signal tower BR 50

Cooling unit series 9

## Ready for any speed.

Labelling machines are used in the food and beverage industry. These apply labels to bottles and cans with great precision and at high speeds.

### Maximum performance for high-speed processes.

Labelling machines are generally located in climatically stable environments; electronic components in electrical enclosures are cooled using powerful and energy-efficient 4.0 series £COOL filterfans.

Type BR 50 signal towers ensure reliable signaling of all process states. With a lifetime of over 50,000 hours, they provide a technically and economically optimum solution.



### Quality control with no downtime.

Quantities and weights are checked and labels, closures and seals are inspected. These processes happen at high throughput rates, in fractions of seconds.

For this, compact cooling units in stainless steel ensure reliable cooling of the sophisticated weight and quality monitoring control units.

To display process states accurately and trigger an alarm if necessary – integrated function-monitored status lights with a high IP protection system and audible alarms are used.



### Security right to the end.

In the field of secondary packaging, cartoners and bulk packers are used. Compact series 3 cooling units are responsible for cooling the electrical enclosure electronics.

With IP 56 protection and a corrosion-free stainless steel hood, the maintenance-free units used in packaging processes prove to be significantly resistant to external factors.

Because of the weight and size of the moving parts, signaling devices with a high protection system are required. This is a specification which our Quadro F12 flashing light with IP 56 protection (IK08) fully satisfies.



Flashing light Quadro F12

£COOL Filterfan 4.0, stainless steel design

## Construction industry: Building safety throughout the world.

Modern towns and cities are multi-functional living and working spaces in which technical solutions allow everyday life to run smoothly. Especially in public and commercial buildings, our products help ensure that many processes run smoothly and keep millions of people safe.

### 24/7 Reliability.

Our products meet the most rigorous requirements and are suitable for use in a wide range of fields. For example, our visual and audible signaling devices: They alert in the event of danger, fire, burglary, accident or technical faults and warn people in every corner of a building – even in large public areas such as railway stations. Our products even provide safety in aviation, for example when used to light up obstacles such as tall buildings and bridges.



### Intelligent solutions on every corner.

Schools, hospitals, public facilities, office buildings, factories – they are all dependent on properly operating building technology. Here, our innovative thermal management solutions protect sensitive electronic control systems from failing.

Especially in winter and in a damp climate, our heaters and thermostats are indispensable. Systems that they reliably protect include: control barriers, overhead roller doors, parking ticket dispensers, and access controls. They protect against condensate risks and ensure that a variety of processes run smoothly.

### Some of the features our solutions for the safety of commercial and public buildings include are:

- Audible and visual alarms.
- Fire and gas alarms.
- Obstacle warning lighting on tall buildings.
- Thermal management for electronic controls.



## Road work: More than just a light at the end of the tunnel.



The steady growth of traffic in metropolitan areas and growth in provinces creates the need for traffic routes to operate smoothly as well as the need for the construction of new roads and tunnels. Here, our products make a vital contribution to the development and maintenance of the infrastructure.

### Safety for guidance and measurement systems.

To direct traffic and monitor emission levels, guidance systems and environment impact measurement devices are used. Using specific components and solutions, we ensure that these systems work perfectly in rain, frost, humid environments, and summer heat. Our cooling units preserve sensitive control units from overheating while thermostats and hygrometers protect them from cold and the associated risks of condensate.



### Individual solutions for tunnel projects.

The construction of roads and especially of tunnels place high demands on the reliability of signaling and thermal management technology. In tunnel construction, vast drilling machines are used, with control units cooled by powerful air/water heat exchangers and needing reliable protection against condensates by heaters with integrated thermostatic systems.

Once the tunnel is completed, flashing lights and audible signaling devices take on the responsibility of guiding people to a safe location in the event of a problem. In addition, the thermal management for central control system is very demanding. Minimum maintenance requirements, resistance against alternating pressure loads, and compatibility with networks for remote monitoring are only some of the criteria which we meet with our applications.

I.e., our products are monitoring the traffic in the tunnel sections of Paris motorways, in the Lötschberg tunnel, in the Rennsteig tunnel, and in the Gotthard base tunnel – the longest railway tunnel in the world.



For more information about our solutions for tunnel construction, please see the Gotthard base tunnel example in the Solutions chapter on page 200.

## Aviation: Non-stop safety for airports.

In the Middle East and in Asia mega hubs are developing, particularly in China where airport construction is booming. The number of flights and passengers is increasing globally – coupled with the need for reliable safety technology. For airport builders and operators around the world, we are sought-after as a partner with the specific expertise for a variety of safety-relevant applications.

### Perfect processes in the control tower and below.

Maximum operational reliability in airport control centres. Vital recording devices in the control tower are protected against overheating by cooling units. Our products are also used in the sensitive area of luggage inspection. There, **ECOOL** cooling units provide reliable and energy-efficient cooling for X-ray equipment. We even provide specific solutions for the parking areas outside airports, such as heaters, thermostats and hygrometers, to protect parking ticket dispensers reliably against corrosion.



### Visual and audible signaling everywhere.

In all locations within an airport, signaling solutions must be visible and heard in order to be noticed in the event of an alarm. On towers, buildings, and cranes, LED obstacle warning lights alert aviation – especially planes taking off or landing. In the luggage pickup area, continuous and flashing lights signal the start and operation of the conveyor belts. In the event of a gas or fire alarm, visual/audible signaling devices alert visitors and staff.



Cooling unit ECOOL series

Flashing light ABL/ABS

Hygrometer FLZ 600

Siren DS 10

## Port and shipping industry.

Tankers, bulk carriers and container ships transport 90 % of all commercial goods from port to port. Both, on board and in the dockyards and terminals, our products help to get these goods shipped quickly and safely to their destinations around the globe.

### At the heart of port logistics.

Without the reliable work of hydraulic cranes and container bridges, any port would grind to a halt. The electronic control systems must be protected against overheating, condensate and corrosion so that loading and unloading runs smoothly. The thermal management solutions of our **ECOOL** series does this while requiring minimum maintenance costs and providing maximum energy efficiency.

Visual and audible alarms signal loading capacities, warn of movements and give alerts about strong winds. At terminals, our lighting solutions ensure safe operation of automatic traffic guidance systems.

### Safety on board.

Our signaling and alarm components are used on freighters, cruisers, navy ships, and on submarines. Visual and audible signaling devices are used here as well. In the machine room – they notify of gas leakages and in cabins – they trigger fire alarms.



## Water and waste water industry.

No matter if we speak of a municipal or industrial applications, we ensure the reliable operation of water-conducting systems worldwide – from water extraction and treatment to water distribution and waste water treatment.

### Solutions for the whole process chain.

For example, in drinking water treatment plants, users of ozone, UV systems and VFD pumping systems rely on our thermal management solutions to protect control systems. Innovative **ECOOL** series cooling units and robust NEMA 4X and UL-certified cooling units protect switching systems against overheating, condensate and corrosion.

In the field of pumps, controls and machines, our SIL/PL compliant signaling devices are used. They display process states and alert in the event of danger, fire, accident and technical faults. In water treatment facilities, where hazardous vapours can occur, for example during sludge treatment and in digestion tanks, their explosion-proof versions are used.

### Reducing energy costs and protecting the environment.

Water and waste water treatment plants are very energy-intensive – our **ECOOL** devices offer the opportunity of cutting the plant's energy costs and of improving environmental awareness.



# Wind energy: Highly efficient technology for an emergent industry.

The development of wind energy is advancing at a furious rate. It is a development we have been supporting for more than 15 years. The world's leading system manufacturers and their suppliers place their confidence in our innovative thermal management and signaling solutions.



### Available in every region.

Plants in offshore wind parks are exposed to high humidity – reliable thermal management is provided by **ECOOL** air/air heat exchangers which hermetically protect the interiors of electrical enclosures from harsh environmental conditions. Protection against condensate formation is provided by the use of thermostats and hygrometers. They control humidity and temperature, also are combined with heaters or filterfans for electrical enclosures.

In almost all modern systems frequency converters are used. Air/water heat exchangers are the appropriate means of maintaining maximum availability of their sophisticated control electronics even at high ambient temperatures. The maintenance-free units made from corrosion-free stainless steel provide energy-efficient cooling, even when exposed to major dust and dirt contamination.

### Innovation in very confined spaces.

To start up the rotor safely after a stoppage due to weather or maintenance, we have developed a compact, vibration-resistant fan heater. With performance levels ranging from 200 to 1,200 W, with a storage and operating temperature of -40 °C to +70 °C it delivers pitch regulation availability even under extreme conditions. More about this product innovation on page 152.

Where the air is contaminated with dust and sand, **ECOOL** 4th generation filterfans provide reliable cooling for the control units. Thanks to their patented fluted filter mat, they achieve IP 55 protection and a 300 % longer product life. Flow-optimised fins and rotor blades allow for maximum airflow and minimum energy consumption.

The foot of the tower houses, the control technology, and one of its functions is to regulate the torque of the drive train. The innovative DTT series top-mounted cooling units provide a space-saving and efficient thermal management solution for this application. The patented condensate management completely protects the interior of electrical enclosures against condensate and ensures maximum component availability due to its reliable cooling function.

### Signaling and alarms.

Our extremely robust signaling solutions contribute to the smooth operation of wind energy plants – including obstacle warning lighting for aviation, state displays for the tower lifts and audible signals when starting up the plant and fire alarms.

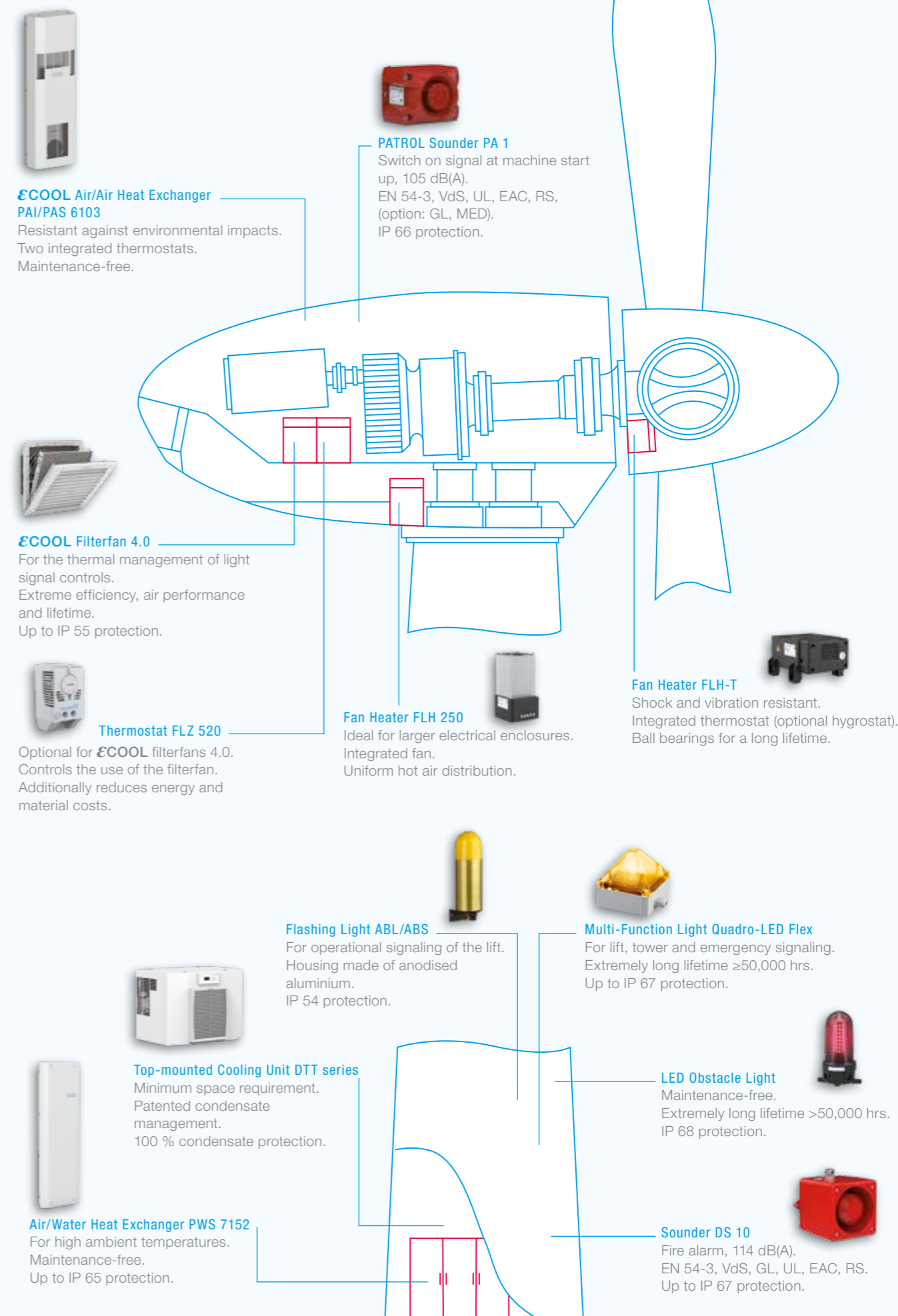

## China's smart grid: Making the energy of the future possible today.

Future power grids will have information and communication capabilities which will enable them to meet the demand for electricity more efficiently, more reliably and more flexibly. As the biggest power consumer in the world, China is investing massively in the transformation of its grid into a modern smart grid – and in doing so relies on our thermal management technology for electrical enclosures.



### Moving forward – with Pfannenberg solutions.

Huge ultra-high voltage transmission routes transmit the wind energy from the North West and water energy from Central China to the mega cities on the country's coast.

Digital transformer stations play a vital role in the development of the intelligent transport network. Their gas-insulated switching systems, voltage and current converters are fitted with smart electrical enclosures which contain components for communicating with the control centre, amongst other features. The fittings for these electrical enclosures include specially developed cooling units from Pfannenberg.

### Smart electrical enclosures – smart thermal management.

Specially equipped type DTI 8161 cooling units are responsible for providing thermal management for the electric components in the smart electrical enclosures. To enable them to be integrated into the communication system of the control centre, they have an intelligent control system and an RS 485 interface for serial high-speed data transfer. Integrated self-diagnosis minimises the need for maintenance, which the unit communicates to the centre if necessary.

Long air ducting enables a perfect airflow through the electrical enclosure and eliminates hot spots. The robust cooling units are supplied in stainless steel housing and, thanks to a condenser with especially wide fin spacing, deliver highly effective protection against severely contaminated and aggressive ambient air.

Since the smart electrical enclosures are generally located outdoors and are exposed to temperature and weather fluctuations, the cooling units have integrated heating. This means that the interior of the electrical enclosure can be protected against corrosion, even in winter and in a humid climate and that temperature can be maintained continuously at a level ideal for the electronic components.



### Maximum control centre availability.

The digital transformer stations in the expanding smart grid in China are equipped with communication-enabled control centres. These are supplied in the form of fully equipped containers. The cooling of its sophisticated electronics is done by powerful outdoor-proof cooling units with the respective communications interfaces.



### The internet of energy.

Creating intelligent, communication-enabled and flexible power grids is regarded as one of the greatest technical challenges of our time. As a leading company in the field of industrial thermal management, we offer solutions for that already today. Across the world, we support the development of smart grids with our innovations – on the way to a global internet of energy.



# Pfannenberg branch offices.

## Pfannenberg Group Holding GmbH

Werner-Witt-Straße 1  
21035 Hamburg  
Germany



## Pfannenberg (UK) Ltd.

Unit 6C, Aspen Court  
Bessemer Way  
Centurion Business Park  
Rotherham S60 1FB  
United Kingdom



## Pfannenberg Inc.

68 Ward Road  
Lancaster, N.Y. 14086  
USA



## Pfannenberg France S.A.R.L.

6th floor  
105 Rue Anatole France  
92300 Levallois-Perret  
France



## Pfannenberg Italia s.r.l.

Via la Bionda, 13  
43036 Fidenza (PR)  
Italy



## Pfannenberg Asia Pacific Pte Ltd

61 Tai Seng Avenue  
# B1-01 UE Print Media Hub  
Singapore 534167  
Singapore



## Pfannenberg Electro-Technology (Suzhou) Co., Ltd.

No. 108 Xinglin Road  
SIP Suzhou 215021, Jiangsu  
P.R. China



## Pfannenberg OOO

Novoroschinskaya ul., 4,  
office 1030-1  
196084 St. Petersburg  
Russia



## Pfannenberg do Brasil Indústria e Comércio Ltda.

Av. Vitória Rossi Martini, 592  
Indaiatuba, SP – 13347-650  
Brazil



## Pfannenberg Europe GmbH

Branch office Austria  
Bärnthäl 1  
4901 Ottnang am Hausruck  
Austria



## Pfannenberg Europe GmbH

Representation Office Poland  
Al. Jana Pawła II 11  
00-828 Warszawa  
Poland



Pfannenberg – worldwide expertise in thermal management and signaling technology.

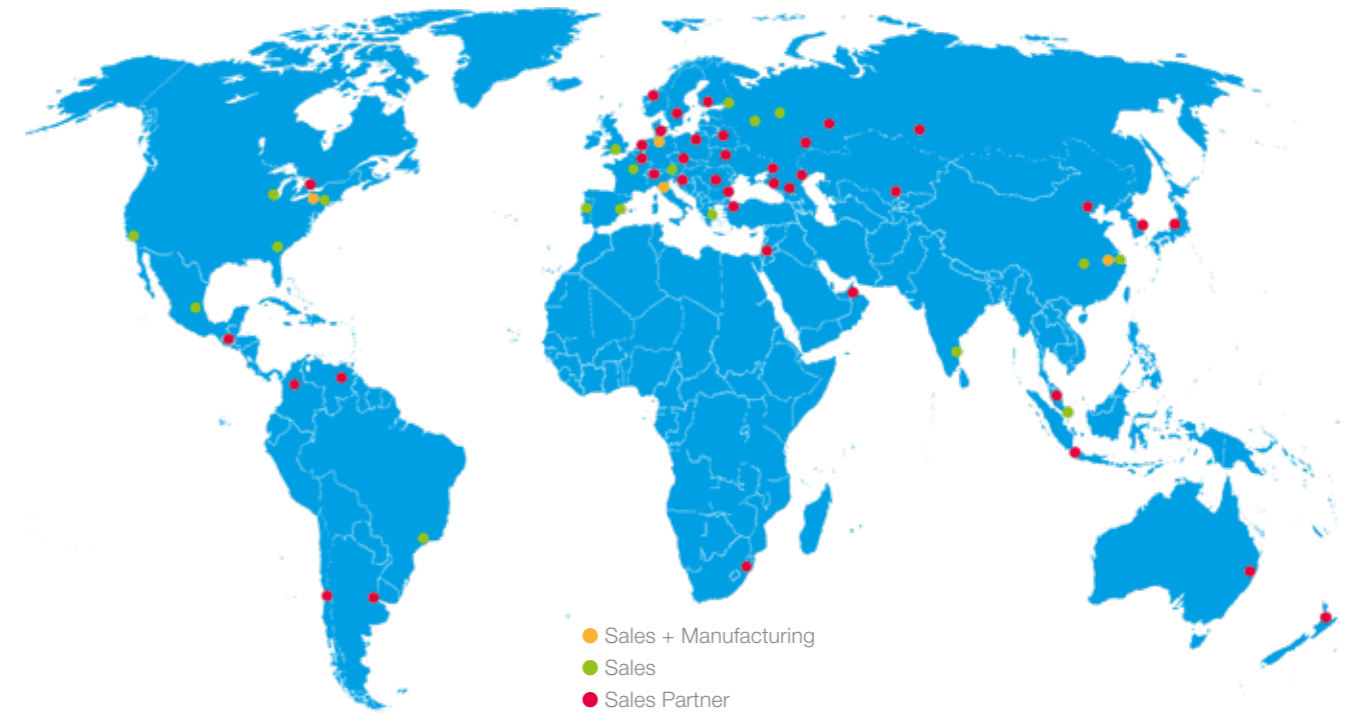

Detailed address information about the worldwide Pfannenberg sales and service partners can be found on our homepage at:

- [pfannenberg.com/contact](http://pfannenberg.com/contact) or
- by entering the Webcode #3559 in the search field on [pfannenberg.com](http://pfannenberg.com).

MY PFANNENBERG | CHOOSE COUNTRY IN

Pfannenberg [pfannenberg.com](http://pfannenberg.com)

ABOUT | PRODUCTS | SERVICE & SUPPORT | NEWS & PRESS | CAREER | SOLUTIONS | KNOW-HOW | CONTACT

#3559 SEARCH

**PROTECTING MAN, MACHINE AND THE ENVIRONMENT.**

Pfannenberg is a global manufacturer of products and solutions for all industries developed to keep critical operations online and personnel safe.

Thermal Management | Signaling Technologies | Liquid Cooling | Services / Support

# The Pfannenberg group worldwide

Pfannenberg Europe GmbH  
Werner-Witt-Straße 1  
21035 Hamburg  
Germany

Phone: +49 40 73412 156  
Telefax: +49 40 73412 101  
Email: [info@pfannenberg.com](mailto:info@pfannenberg.com)  
Web: [www.pfannenberg.com](http://www.pfannenberg.com)

Pfannenberg Austria, Ottnang am Hausruck  
Phone: +43 7676 50219  
Email: [info.austria@pfannenberg.com](mailto:info.austria@pfannenberg.com)

Pfannenberg Brazil, Indaiatuba  
Phone: +55 19 3935 7187  
Email: [info@pfannenberg.com.br](mailto:info@pfannenberg.com.br)

Pfannenberg China, Suzhou  
Phone: +86 512 6287 1078  
Email: [info@pfannenberg.cn](mailto:info@pfannenberg.cn)

Pfannenberg France, Rueil-Malmaison  
Phone: +33 1 4708 4747  
Email: [info@pfannenberg.fr](mailto:info@pfannenberg.fr)

Pfannenberg Italy, Fidenza (PR)  
Phone: +39 0524 516 711  
Email: [info@pfannenberg.it](mailto:info@pfannenberg.it)

Pfannenberg Poland, Warsaw  
Phone: +48 228907246  
Email: [info@pfannenberg.pl](mailto:info@pfannenberg.pl)

Pfannenberg Russia, St. Petersburg  
Phone: +7 812 612 8106  
Email: [info@pfannenberg.ru](mailto:info@pfannenberg.ru)

Pfannenberg Singapore, Singapore  
Phone: +65 6293 9040  
Email: [info@pfannenberg.com.sg](mailto:info@pfannenberg.com.sg)

Pfannenberg United Kingdom, Rotherham  
Phone: +44 1709 36 4844  
Email: [info@pfannenberg.co.uk](mailto:info@pfannenberg.co.uk)

Pfannenberg USA, N.Y.  
Phone: +1 716 685 6866  
Email: [info@pfannenbergusa.com](mailto:info@pfannenbergusa.com)

Deliveries are made on the basis of the General Terms and Services of the ZVEI. Subject to technical amendments and misprints. This paper has been manufactured from chlorine-free bleached cellulose. 01/21/2020



075000293

