

Thermistor monitoring S1MN





The S1MN thermistor monitoring relay is used in temperature monitoring circuits in accordance with EN 44081 to protect motors, generators, storage areas etc. from overheating.

Features

- For DC and AC supplies
- Normally energised mode
- Fault latching or automatic reset
- Manual reset via internal or external reset button

Approvals

	S1MN
	●
	●*
	●

* for versions up to 240 V AC

Technical Details	S1MN
Electrical data	
Supply voltage	AC: 48, 110, 230, 240, 400 V AC/DC: 24 V
Tolerance	-15 %/+10 %
Power consumption	AC: 3.5 VA, DC: 2 W
Usage category in accordance with EN 60947-4-1	AC1: 240 V/0.1 ... 5 A/1200 VA DC1: 24 V/0.1 ... 5 A/120 W
EN 60947-5-1	AC15: 230 V/2 A; DC13: 24 V/1.5 A
Output contacts	2 auxiliary contacts (2 C/O)
Contact material	AgCdO, 3 µm gold plating for low-load range 1-50 V/1-100 mA
Contact fuse protection in accordance with EN 60947-5-1	
Blow-out fuse quick acting	6 A
Blow-out fuse slow acting	4 A
Safety cut-out, 24 V AC/DC characteristic B/C	4 A
Measuring circuit	
Response value for sensor short-circuit	Approx. 25 Ohm
Delay on energisation	Approx. 500 ms
Response value	3.6 kOhm ± 10 %
Release value	1.8 kOhm ± 10 %
Resistance at 20 °C	Max. 1.5 kOhm
Mechanical data	
Max. cable cross section of ext. conductor single core	1 x 4 mm ² , 24 - 10 AWG
multi-core with crimp connectors	2 x 2,5 mm ² , 24 - 14 AWG
Dimensions (H x W x D)	87 x 22.5 x 121 mm
Weight	AC: 160 g; DC: 120 g
Designation	⊕ II (3) G/D [EEx nL] IIC

Description

The thermistor monitoring relay is enclosed in an S-95 slimline housing. There are various AC versions available and one version for AC/DC operation.

Features:

- Relay outputs:
2 auxiliary contacts (2 C/O)
- Measuring circuit for connecting a temperature sensor (PTC-resistor)
- Monitoring temperature sensor for short circuits
- LED for supply voltage and faults

A temperature sensor is connected to the S1MN measuring circuit. If the temperature exceeds a defined value, i.e. the resistance of the temperature sensor reaches the response value, the output contacts switch.

If the temperature falls once more, i.e. the resistance of the temperature sensor reaches the release value, the auxiliary contacts switch again if automatic reset has been selected. The unit is then ready for operation. If manual reset is selected, an internal or external reset button must be activated. Reset can also occur by interrupting the supply voltage.

Thermistor monitoring S1MN

Internal wiring diagram

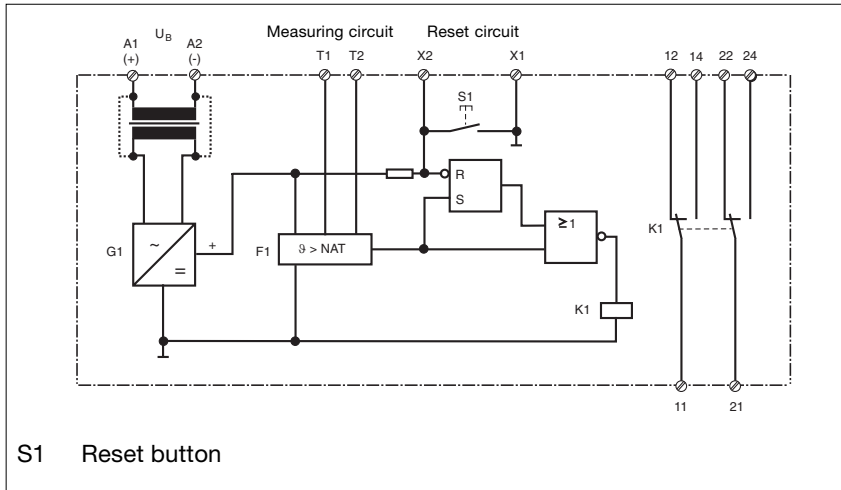

Timing diagram

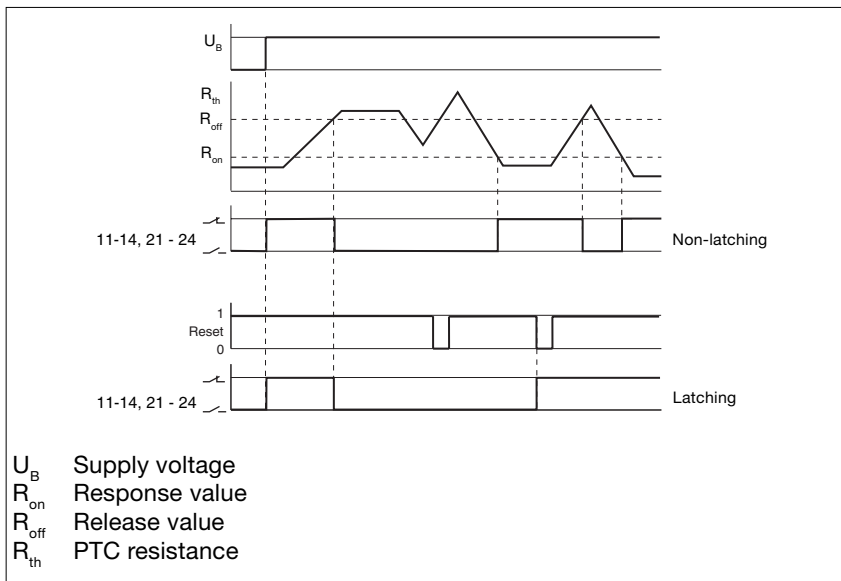

Thermistor monitoring S1MN

Connection examples

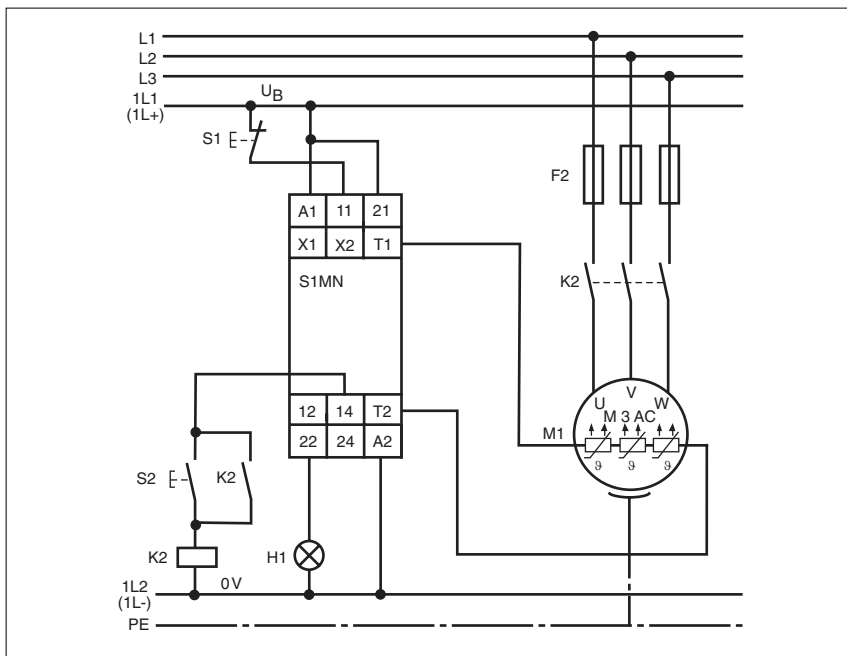

Thermistor monitoring S1MN

General Details

Unless stated otherwise in the technical details for the specific unit.

Electrical data

AC frequency range	50 ... 60 Hz
DC residual ripple	160 %
Contact material	AgCdO
Continuous duty	100 %

Environmental data

EMC	EN 60947-5-1, EN 61000-6-2
Vibration in accordance with EN 60068-2-6, 04/95	Frequency: 10 ... 55 Hz Amplitude: 0.35 mm
Climatic suitability	EN 60068-2-78
Airgap creepage	EN 60947-1, EN 60079-15
Ambient temperature	-10 ... +55 °C
Storage temperature	-40 ... +85 °C

Mechanical data

Torque setting for connection terminals (screws)	0.6 Nm
Mounting position	Any
Housing material	
Front	ABS UL 94 V0
Housing	PPO UL 94 V0
Protection types	
Mounting:	IP 54
Housing:	IP 40
Terminals:	IP 20

The version of the standards current at 2005-10 apply.

Order references key
U_B Supply voltage

Order references

Type	U _B	Order no.
S1MN	24 V AC/DC	839 400
S1MN	48 V AC	839 405
S1MN	110 V AC	839 410
S1MN	230 V AC	839 415
S1MN	240 V AC	839 420
S1MN	400 V AC	839 425

Additional versions available on request