



### BUFFER MODULE

- Buffering with electrolytic capacitors instead of lead acid batteries
- Buffering of 24V loads
- Minimum hold-up time 0.2s at 20A, longer hold-up time at lower loads
- Clear status indication by status LED and signaling terminals
- Quick-connect spring-clamp terminals
- 3 Years warranty

### GENERAL DESCRIPTION

The UF20 buffer module is a supplementary device for regulated DC 24V power supplies, which can be used for various purposes:

- Deliver DC-power to bridge failures of the DC voltage supply system.
- Extend the hold-up time after loss of the AC power.
- Deliver extra short-term peak current above the current rating of the power supply.

It utilizes service-free electrolytic capacitors for storing the energy which allows usage even at ambient temperatures up to +70°C.

The buffer module does not require any control wiring. It can be added in parallel to the load circuit at any given point.

Buffer modules can be connected in parallel to increase the output ampacity or the hold-up time.

### SHORT-FORM DATA

Supply voltage	DC 24V <sup>-20%/+25%</sup>	19.2-30Vdc
Required voltage to charge capacitors	23Vdc	
Threshold voltage for buffer mode	22.5V / V <sub>IN</sub> -1V	Selectable
Buffer voltage	22.5V / V <sub>IN</sub> -1V	Selectable
Buffer current	20A	
Charging time	Typ. 25s	
Current consumption	Typ. 80mA Max. 600mA	Stand-by mode During charging
Power dissipation	1.9W	Stand-by mode
Buffer time	Min. 200ms Min. 430ms Typ. 310ms Typ. 670ms Typ. 43s	At 22.5V, 20A At 22.5V, 10A At 22.5V, 20A At 22.5V, 10A At 22.5V, 0.1A
Temperature range	-25°C to +70°C	Operational
Dimensions	64x124x102mm	WxHxD
Weight	740g / 1.63lb	

### ORDER NUMBERS

Buffer Module	<b>UF20.241</b>	
Accessory	ZM1.WALL	Panel/ wall-mount bracket
	ZM14.SIDE	Side-mount bracket

### MARKINGS



## INDEX

	Page		Page
1. Intended Use .....	3	15. Terminals and Wiring .....	10
2. Installation Notes .....	3	16. Front Side and User Elements .....	11
3. Functional Description .....	4	17. EMC .....	12
4. Electrical Ratings .....	5	18. Environment .....	13
5. Selection of the Back-up Threshold Voltage .....	6	19. Protection Features .....	13
6. Buffer Time .....	6	20. Safety Features .....	13
7. Charging Time .....	7	21. Dielectric Strength .....	14
8. Operating Diagrams .....	7	22. Approvals .....	14
9. Active Signal .....	8	23. Physical Dimensions and Weight .....	15
10. Ready Signal .....	8	24. Accessories .....	16
11. Inhibit Input .....	8	24.1. ZM1.WALL - Wall mounting bracket .....	16
12. Efficiency and Power Losses .....	9	24.2. ZM14.SIDE - Side Mounting Bracket .....	17
13. Lifetime Expectancy and MTBF .....	9	25. Wiring Diagrams .....	18
14. Functional Diagram .....	10		

The information given in this document is correct to the best of our knowledge and experience at the time of publication. If not expressly agreed otherwise, this information does not represent a warranty in the legal sense of the word. As the state of our knowledge and experience is constantly changing, the information in this data sheet is subject to revision. We therefore kindly ask you to always use the latest issue of this document (available under [www.pulspower.com](http://www.pulspower.com)). No part of this document may be reproduced or utilized in any form without our prior permission in writing.

Some parts of this unit are patent by PULS (US patent No 091662,063, Des. 424,529, ...).

## TERMINOLOGY AND ABBREVIATIONS

<b>Power supply mode</b>	Describes a condition where the supply voltage is in the rated supply voltage range and the supplying power supply can deliver a sufficient amount of current for the buffer module and the load. The mode can also be called "Normal mode".
<b>Buffer mode</b>	Describes a condition where the input voltage is below the transfer threshold level, the unit is running on capacitors (buffering) and the output is loaded within the allowed limits. The mode can also be called "Capacitor mode".
<b>Inhibit mode</b>	Describes a condition where buffering is disabled on purpose (e.g. for service actions).
<b>T.b.d.</b>	To be defined, value or description will follow later.
<b>DC 24V</b>	A figure displayed with the AC or DC before the value represents a nominal voltage with standard tolerances included. E.g.: DC 12V describes a 12V battery disregarding whether it is full (13.7V) or flat (10V).
<b>24Vdc</b>	A figure with the unit (Vdc) at the end is a momentary figure without any additional tolerances included.
<b>may</b>	A key word indicating flexibility of choice with no implied preference.
<b>shall</b>	A key word indicating a mandatory requirement.
<b>should</b>	A key word indicating flexibility of choice with a strongly preferred implementation.

### 1. INTENDED USE

This device is designed for installation in an enclosure. Use an appropriate enclosure which protects against mechanical, electrical and fire hazards.

This device is intended for professional use in areas such as in industrial control, office, communication, and instrumentation equipment.

Do not use this device in equipment or systems where malfunction may cause severe personal injury or threaten human life.

### 2. INSTALLATION NOTES

This device may only be installed and put into operation by qualified personnel.

This device does not contain serviceable parts or fuses.

If damage or malfunction should occur during installation or operation, immediately turn power off and send unit to the factory for inspection.

The unit must be powered from a SELV source (according to IEC 60950-1), PELV source (according to IEC 62477-1) or an Isolated Secondary Circuit (according to UL 508) power source.

Use DIN-rails according to EN 60715 with a height of 7.5 or 15mm.

Mounting orientation must be power terminals on top of the unit.

Do not obstruct air flow as the unit is convection cooled. Ventilation grid must be kept free of any obstructions.

Signal lines (ready, active and inhibit) must be shorter than 30m.

Use an appropriately sized power supply, which can deliver the additional required internal current consumption (including the charging current) specified as input current in the table of chapter 4 and Fig. 4-1.

The following installation clearances must be maintained:

- Left / right: 0mm
- On top of the unit: 40mm
- On bottom of the unit: 20mm

Agency approvals apply only for altitudes up to 2000m.

Maximum surrounding air temperature: +70°C / +158°F.

Caution for Canada: For use in a controlled environment according to CSA 22.2 No 107.1-01.

#### WARNING

Risk of electrical shock, fire, personal injury or death.

- Turn power off before working on the device. Protect against inadvertent re-powering.
- Make sure that the wiring is correct by following all local and national codes.
- Do not modify or repair the unit.
- Do not open the unit as dangerous voltages may be present inside.
- Use caution to prevent any foreign objects from entering the housing.
- Do not use in wet locations or in areas where moisture or condensation can be expected.
- Do not touch during power-on, and immediately after power-off. Hot surfaces may cause burns.

## 3. FUNCTIONAL DESCRIPTION

### Working principle

When the power supply provides sufficient voltage, the buffer module stores energy in the integrated electrolytic capacitors. In case of a voltage dip or loss, this energy is released to the DC bus in a regulated process.

### Bridges mains faults without interruption

Statistic show that 80% of all mains fault lasts less than 0.2s. These mains faults are completely bridged by the buffer unit. This increases the reliability of the system as a whole.

### Extended hold-up time

Once mains power fails or is switched off, the buffer unit will continue to provide the load current for a defined period of time. Process data can be saved and processes can be terminated before the DC power switches off. Controlled restarts are subsequently possible.

### Easy to handle, expandable and maintenance-free

The buffer module does not require any control wiring. It can be added parallel to the load circuit at any given point. Buffer modules can be connected in parallel to increase the output ampacity or the hold-up time.

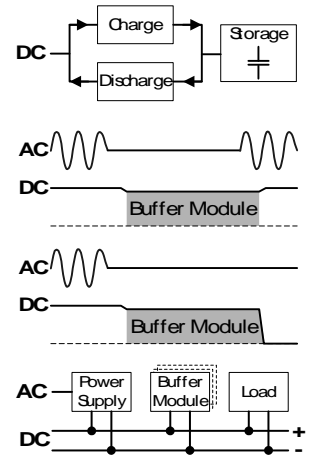

Fig. 3-1 Typical wiring diagram

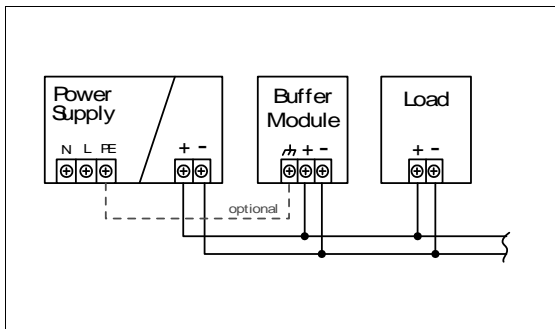
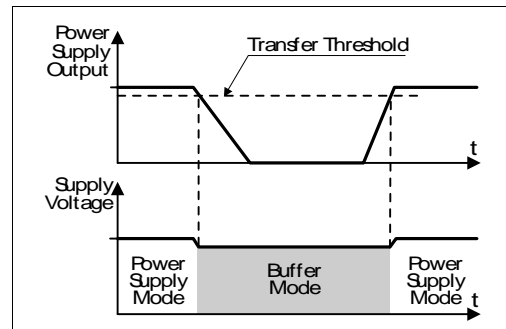

Fig. 3-2 Transfer behavior



## 4. ELECTRICAL RATINGS

Supply voltage	Nom.	DC 24V $-20%/+25\%$	
Supply voltage range <sup>1)</sup>	Nom.	19.2 - 30Vdc	
Normal operating voltage range <sup>2)</sup>	Typ.	23 – 30Vdc	
Transfer voltage for switching into buffer mode	Typ.	22.5Vdc	Back-up threshold jumper set to "22.5V fixed"
	Typ.	$V_{IN} - 1V$	Back-up threshold jumper set to " $V_{IN} - 1V$ " See also chapter 5.
Transfer voltage for switching from buffer mode into power supply mode	Typ.	22.5Vdc	Back-up threshold jumper set to "22.5V fixed"
	Typ.	$V_{BUFFER} + 1V$	Back-up threshold jumper set to " $V_{IN} - 1V$ " See also chapter 5.
Buffer voltage	Typ.	Same as the transfer voltage for switching into buffer mode.	
Ripple and noise voltage	Max.	200mVpp	Generated by the buffer module. Defined at 20Hz to 20MHz, 50Ohm
		The ripple and noise voltage is defined by the power supply.	
Current consumption	Typ.	80mA	When capacitor is fully charged
	Min.	400mA	During charging of the capacitors
	Max.	600mA	During charging of the capacitors
Power dissipation	Typ.	1.9W	When capacitor is fully charged
Buffer current	Min.	20A	
Buffer current overload behavior		Electronically limited, buffering stops and capacitor gets discharged below 17V. See Fig. 4-2.	
Allowed voltage between supply voltage and chassis ground	Max.	60Vdc or 42.4Vac	Continuous, IEC 62477-1
Capacitive and inductive loads		No limitation	

**1) Supply Voltage Range:**

At voltages within the input voltage range, control functions such as LEDs, monitoring features, relay contacts, etc. are functioning normally. Within the input voltage range the unit can either be in power supply mode or in buffer mode.

**2) Normal Operating Voltage Range:**

The normal operating voltage range describes the supply voltage, which supports the full functionality of the buffer module (including charging) but without entering the buffer mode.

Fig. 4-1 Selection of an appropriate power supply

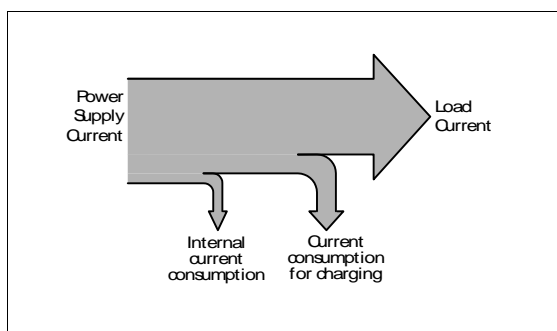
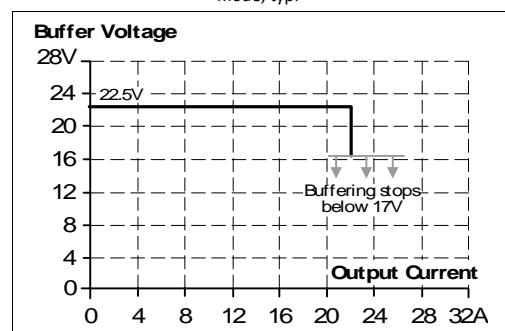

Fig. 4-2 Output characteristic in buffer mode, 22.5V fixed mode, typ.



## 5. SELECTION OF THE BACK-UP THRESHOLD VOLTAGE

The buffer behavior can be selected with the back-up jumper selector between “Fixed Mode” and “Variable Mode”.

**Fixed Mode:** (Jumper in position „2-3“ or „22.5V fixed“)

If the supply output voltage falls below 22.5V, buffering starts and the supply voltage will be kept at this level.

This adjustment is recommended:

- when power supplies other than the DIMENSION Q-series are used
- with back-feeding loads
- when the buffer module is placed close to the load or
- whenever in doubt.

**Variable Mode:** (Jumper in position „1-2“ or „ $V_{IN} - 1V$ “)

Buffering starts if the supply voltage decreases by more than 1V. Buffering ends when supply voltage increases by more than 1V

Voltage changes slower than 0.54V/s will be ignored if the voltage is above 22.5V. Below 22.5V buffering starts immediately.

This adjustment is recommended for any application where 22.5V is too low for the application or when the buffer module is placed close to the power supply.

The factory setting is fixed mode, A missing jumper means also fixed mode.

## 6. BUFFER TIME

The buffer time (sometimes also called autonomy time) is the maximum period of time for which the capacitor can maintain the required output current. The buffer time mainly depends on the output current in buffer mode.

To increase the buffer time any given number of buffer modules can be connected in parallel.

Buffer time	Min.	200ms	At 22.5V, 20A
	Min.	430ms	At 22.5V, 10A
	Typ.	310ms	At 22.5V, 20A
	Typ.	670ms	At 22.5V, 10A
	Typ.	43s	At 22.5V, 0.1A

Fig. 6-1 Buffer time, typ.

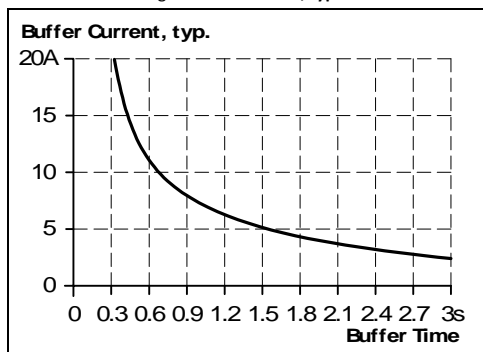
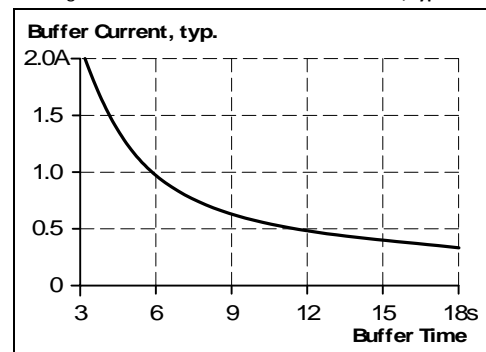

Fig. 6-2 Buffer time for small buffer currents, typ.



### 7. CHARGING TIME

Charging of the internal capacitors is indicated by the status LED, which is flashing with a slow frequency (1.25Hz).

Charging time	Min.	20s	Initial charging <sup>1)</sup>
	Max.	30s	Initial charging <sup>1)</sup>
	Min.	18s	Re-charging <sup>2)</sup>
	Max.	28s	Re-charging <sup>2)</sup>

- 1) Initial charging is the first charge after voltage is applied to the buffer module.
- 2) Re-charging is the charging of the internal capacitors after voltage interruptions shorter than 2minutes.

Fig. 7-1 Charging time, re-charging

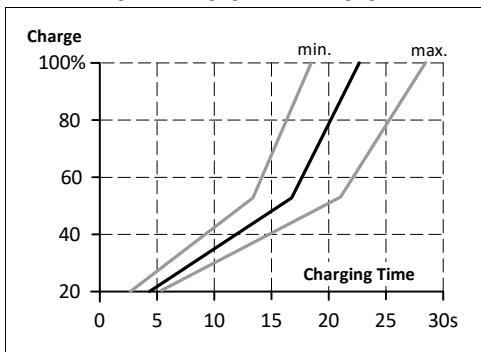

### 8. OPERATING DIAGRAMS

Fig. 8-1 Operating diagram

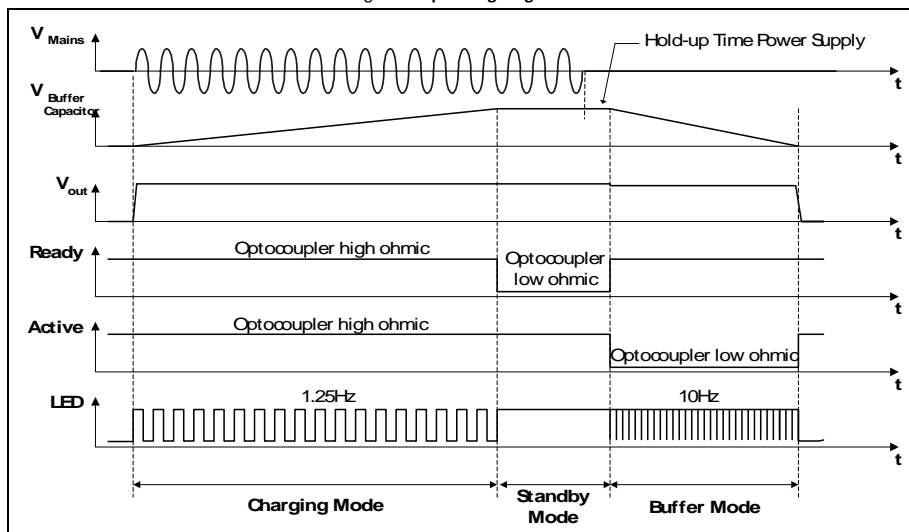
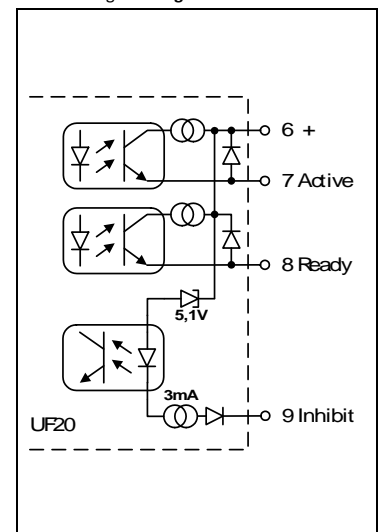

Fig. 8-2 Signal schematic



### 9. ACTIVE SIGNAL

The signal "Active" (pin 7) is an opto-coupler output which is low ohmic while buffer capacitors are discharged.  
Wiring scheme see Fig. 8-2, Fig. 25-1 and Fig. 25-2.

Signal voltage	Max.	35Vdc	Voltage between pin 6 and 7
Signal current	Max.	10mA	
Voltage drop across opto-coupler		0.9V / 3V	At 1mA / 5mA while opto-coupler is low ohmic
Leakage current	Max.	50µA	While opto-coupler is high ohmic
Isolation voltage		See chapter 21.	

### 10. READY SIGNAL

The signal "Ready" (pin 8) is an opto-coupler output which is low ohmic when buffer capacitors are fully charged.  
Wiring scheme see Fig. 8-2, Fig. 25-1 and Fig. 25-2.

Signal voltage	Max.	35Vdc	Voltage between pin 6 and 8
Signal current	Max.	10mA	
Voltage drop across opto-coupler		0.9V / 3V	At 1mA / 5mA while opto-coupler is low ohmic
Leakage current	Max.	50µA	While opto-coupler is high ohmic
Isolation voltage		See chapter 21.	

### 11. INHIBIT INPUT

Buffering can be disabled or interrupted with the inhibit input (pin 9). Therefore, pin 6 should be connected to the positive pole of the terminal voltage or to the external control voltage and pin 9 must be connected to the corresponding negative pole.

Inhibiting the unit also discharges the internal capacitors. Charging of the capacitor is not possible when the buffer module is in inhibit mode.

Wiring scheme see Fig. 8-2, Fig. 25-1 and Fig. 25-2.

Signal voltage	Max.	35Vdc (between pin 6 and pin 9)	
Signal current	Max.	4mA, current limited	
Inhibit mode		The unit does not buffer (or stops buffering) if the voltage between pin 6 and pin 9 is higher than 10V. Below 6V buffering will function again.	
Isolation voltage		See chapter 21.	



### 12. EFFICIENCY AND POWER LOSSES

Efficiency	Typ.	>99%	Power supply mode, 20A output current, capacitors fully charged
Power losses	Typ.	1.9W	Power supply mode, 0A output current, capacitors fully charged

### 13. LIFETIME EXPECTANCY AND MTBF

Calculated lifetime expectancy <sup>*)</sup>	166 000h <sup>*)</sup>	Stand-by mode, 40°C
	469 000h <sup>*)</sup>	Stand-by mode, 25°C
MTBF <sup>**)</sup> SN 29500, IEC 61709	2 327 000h	Stand-by mode, 40°C
	4 219 000h	Stand-by mode, 25°C
MTBF <sup>**)</sup> MIL HDBK 217F	398 000h	Stand-by mode, 40°C, Ground Benign GB40
	624 000h	Stand-by mode, 25°C Ground Benign GB25
	132 000h	Stand-by mode, 40°C, Ground Fixed GF40
	195 000h	Stand-by mode, 25°C Ground Fixed GF25

\*) The **calculated lifetime expectancy** shown in the table indicates the minimum operating hours (service life) and is determined by the lifetime expectancy of the built-in electrolytic capacitors. Lifetime expectancy is specified in operational hours and is calculated according to the capacitor's manufacturer specification. The manufacturer of the electrolytic capacitors only guarantees a maximum life of up to 15 years (131 400h). Any number exceeding this value is a calculated theoretical lifetime which can be used to compare devices.

\*\*) **MTBF** stands for **Mean Time Between Failure**, which is calculated according to statistical device failures, and indicates reliability of a device. It is the statistical representation of the likelihood of a unit to fail and does not necessarily represent the life of a product.  
The MTBF figure is a statistical representation of the likelihood of a device to fail. A MTBF figure of e.g. 1 000 000h means that statistically one unit will fail every 100 hours if 10 000 units are installed in the field. However, it cannot be determined if the failed unit has been running for 50 000h or only for 100h.

### 14. FUNCTIONAL DIAGRAM

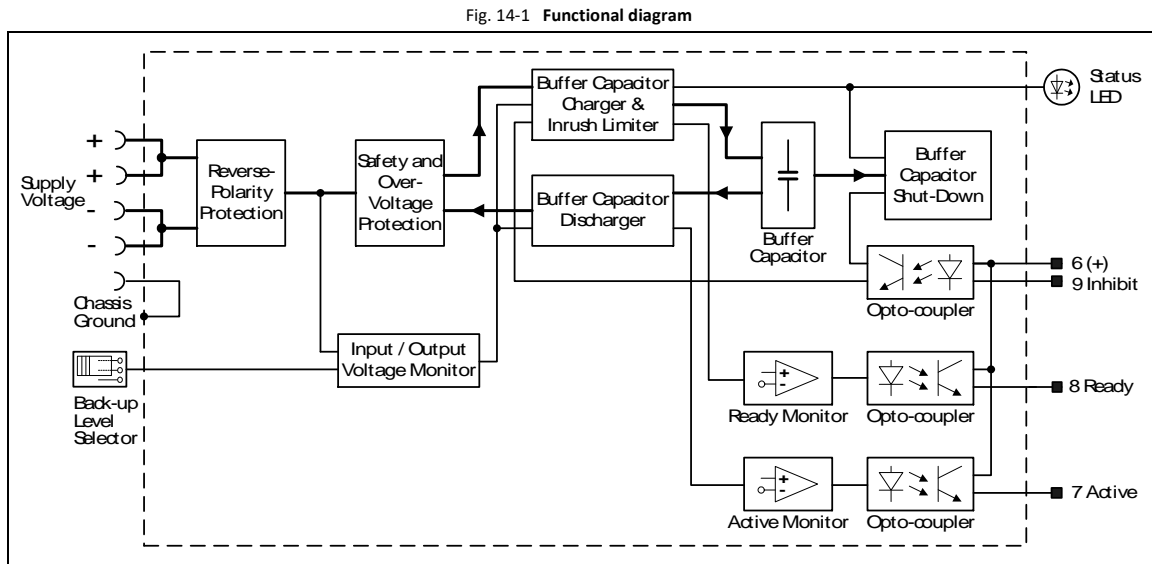

### 15. TERMINALS AND WIRING

The terminals are IP20 finger safe constructed and suitable for field and factory wiring.

	Supply voltage, chassis ground	Signals
<b>Type</b>	Quick-connect spring-clamp terminals	Pluggable screw terminals
Solid wire	Max. 6mm <sup>2</sup>	Max. 2.5mm <sup>2</sup>
Stranded wire	Max. 4mm <sup>2</sup>	Max. 2.5mm <sup>2</sup>
American Wire Gauge	Max. AWG 20-10	AWG 22-14
Max. wire diameter	Max. 2.8mm (including ferrules)	2.25mm (including ferrules)
Wire stripping length	Typ. 10mm / 0.4inch	6mm / 0.25inch
Tightening torque	Not applicable	0.4Nm / 3.5lb.inch
Screwdriver	Not applicable	3mm slotted

**Instructions:**

- Use appropriate copper cables that are designed for minimum operating temperatures of:  
 60°C for ambient up to 45°C and  
 75°C for ambient up to 60°C and  
 90°C for ambient up to 70°C minimum.
- Follow national installation codes and installation regulations!
- Ensure that all strands of a stranded wire enter the terminal connection!
- Unused terminal compartments should be securely tightened or closed.
- Ferrules are allowed.

### 16. FRONT SIDE AND USER ELEMENTS

Fig. 16-1 Front side

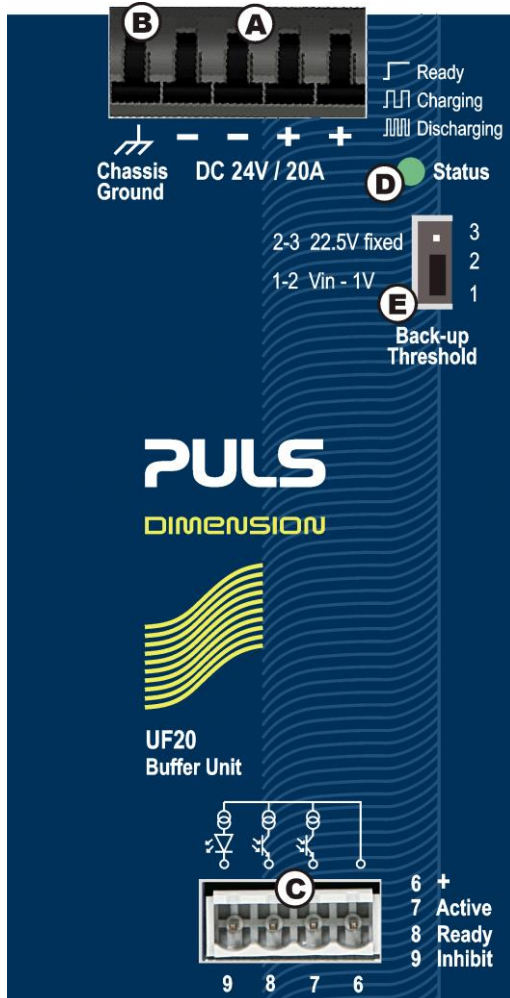

#### A Supply Voltage Terminals

Quick-connect spring-clamp terminals, two per polarity  
 + Positive supply voltage terminal  
 - Negative (return) supply voltage terminal

#### B Chassis Ground Terminal

Quick-connect spring-clamp terminals  
 Connection of the chassis to ground (earth) is optional and only required for a view specific applications.

#### C Signal Connector

4-pole plug connector with screw termination comprises the following signals:

- "Active" signal, for details see chapter 9.
- "Ready" signal, for details see chapter 10
- "Inhibit" input, for details see chapter 11

#### D Status LED

This green LED indicates that the following information:  
 - OFF: Capacitors are discharged or supply voltage is below 22V.  
 - ON: Capacitors are fully charged  
 - Slow flashing (1.25Hz): Capacitors are getting charged.  
 - Fast flashing (10Hz): Capacitors are getting discharged.

#### E Back-up Threshold Jumper

Option 1: Fixed mode (Jumper in position 2-3)

The unit switches to buffer mode as soon as the voltage falls below 22.5V.

Option 2: Variable mode (Jumper in position 1-2)

Unit switches to buffer mode when input voltage decreases by 1V. Voltage changes slower than 0.54V/s will be ignored if the voltage is above 22.5V.

Below 22.5V buffering starts immediately.

For more details see chapter 5.

## 17. EMC

The buffer module is suitable for applications in industrial environment as well as in residential, commercial and light industry environment.

**EMC Immunity** According to generic standards: EN 61000-6-1 and EN 61000-6-2  
for all operating modes

Electrostatic discharge	EN 61000-4-2	Contact discharge *) Air discharge *)	8kV 15kV	Criterion A Criterion A
Electromagnetic RF field	EN 61000-4-3	80MHz-2.7GHz	10V/m	Criterion A
Fast transients (Burst)	EN 61000-4-4	Input lines Output lines Signals lines pin 6, 7, 8, 9 **)	2kV 2kV 2kV	Criterion A Criterion A Criterion A
Surge voltage on supply voltage terminals	EN 61000-4-5	+ → - + / - → chassis ground	0.5kV 1kV	Criterion A Criterion A
Surge voltage on inhibit input, active signal and ready signal	EN 61000-4-5	Not applicable since length of signal wire specified shorter than 30m.		
Conducted disturbance	EN 61000-4-6	0.15-80MHz	10V	Criterion A

\*) Chassis ground connection earthed (grounded)

\*\*) Tested with coupling clamp

**Criteria:**

**A:** Buffer module shows normal operation behavior within the defined limits.

**EMC Emission** According to generic standards: EN 61000-6-3 and EN 61000-6-4  
for standby- and charging mode

Conducted emission, supply voltage	IEC/CISPR 16-1-2, IEC/CISPR 16-2-1	Limits for DC power ports acc. EN 61000-6-3 fulfilled
Radiated emission	EN 55011, EN 55022	Class B

This device complies with FCC Part 15 rules.

Operation is subjected to following two conditions: (1) this device may not cause harmful interference, and (2) this device must accept any interference received, including interference that may cause undesired operation.

**Switching Frequency** The buffer module has two converters with variable frequencies included.

6 to 610kHz	Charging converter at 24V input (is only active during charging) The frequency depends on the state of charge of the capacitors
10 to 70kHz	Buffer converter at buffering at 22.5V The frequency depends on the output current. The values are between 10% and 100% of the nominal buffer current

## 18. ENVIRONMENT

Operational temperature *)	-25°C to +70°C (-13°F to 158°F)	
Storage temperature	-40 to +70°C (-40°F to 158°F)	For storage and transportation
Humidity **)	5 to 95% r.H.	IEC 60068-2-30
Vibration sinusoidal	2-17.8Hz: ±1.6mm; 17.8-500Hz: 2g 2 hours / axis	IEC 60068-2-6
Vibration random	0.5m <sup>2</sup> (s <sup>3</sup> ) 2 hours / axis	IEC 60068-2-64
Shock	30g 6ms, 20g 11ms 3 bumps / direction, 18 bumps in total	IEC 60068-2-27
Altitude	0 to 6000m (0 to 20 000ft)	Approvals apply only up to 2000m
Over-voltage category	III	IEC 62103, EN 62477-1
	II	IEC 62103, EN 62477-1, above 2000m altitude
Degree of pollution	2	IEC 62103, EN 62477-1, not conductive
LABS compatibility	The unit does not release any silicone or other LABS-critical substances and is suitable for use in paint shops.	

\*) Operational temperature is the same as the ambient or surrounding temperature and is defined as the air temperature 2cm below the unit.

\*\*) Do not energize while condensation is present

## 19. PROTECTION FEATURES

Electrical protection	Electronically protected against overload, no-load and short-circuits	
Over-voltage protection in buffer mode	Typ. 32Vdc Max. 35Vdc	In case of an internal buffer module defect, a redundant circuit limits the maximum output voltage. Buffering stops and automatically attempts to restart.
Degree of protection	IP 20	EN/IEC 60529
Penetration protection	> 3.5mm	E.g. screws, small parts
Reverse polarity protection	Yes	Max. -35V
Input overvoltage protection	Yes	Max. 35V, no harm or defect of the unit
Internal input fuse	Not included	

## 20. SAFETY FEATURES

Class of protection	No classification according to IEC 61140 or IEC 60950-1 possible	Install the buffer module according to Class III rules
Isolation resistance	> 500MOhm	Supply voltage to signal port
	> 500MOhm	Supply voltage to housing
	> 500MOhm	Signal port to housing
Chassis ground terminal resistance	< 0.10hm	Between housing and chassis ground terminal

## 21. DIELECTRIC STRENGTH

The signal port (active and ready signal and inhibit input) is floating and separated from the supply voltage.

Type and factory tests are conducted by the manufacturer. Field tests may be conducted in the field using the appropriate test equipment which applies the voltage with a slow ramp (2s up and 2s down). Connect all poles of the power port terminals together as well as all poles of the signal port before conducting the test. When testing, set the cut-off current settings to the value in the table below. The following isolation tests were performed:

Fig. 21-1 Dielectric strength

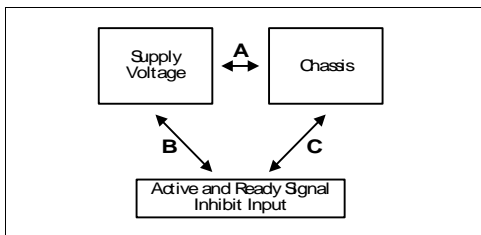

		A	B	C
Type test	60s	500Vac	500Vac	500Vac
Factory test	5s	500Vac	500Vac	500Vac
Field test	5s	500Vac	500Vac	500Vac
Cut-off current setting		> 1mA	> 1mA	> 1mA

## 22. APPROVALS

EU Declaration of Conformity



The CE mark indicates conformance with the EMC directive

IEC 60950-1  
2<sup>nd</sup> Edition



CB Scheme,  
Information Technology Equipment

UL 60950-1  
2<sup>nd</sup> Edition



Recognized for use as Information Technology Equipment, U.S.A. (UL 60950-1) and Canada (C22.2 No. 60950-1);  
E-File: E137006

UL 508



Listed for use as Industrial Control Equipment;  
U.S.A. (UL 508) and Canada (C22.2 No. 107-1-01);  
E-File: E198865

### 23. PHYSICAL DIMENSIONS AND WEIGHT

Width	64mm	2.13"
Height	124mm	4.88"
Depth	102mm	4.02"
	The DIN-rail height must be added to the unit depth to calculate the total required installation depth.	
Weight	740g / 1.63lb	
DIN-rail	Use 35mm DIN-rails according to EN 60715 or EN 50022 with a height of 7.5 or 15mm.	
Housing material	Body: Aluminium alloy Cover: Zinc-plated steel	
Installation clearances	See chapter 2	

Fig. 23-1 Front view

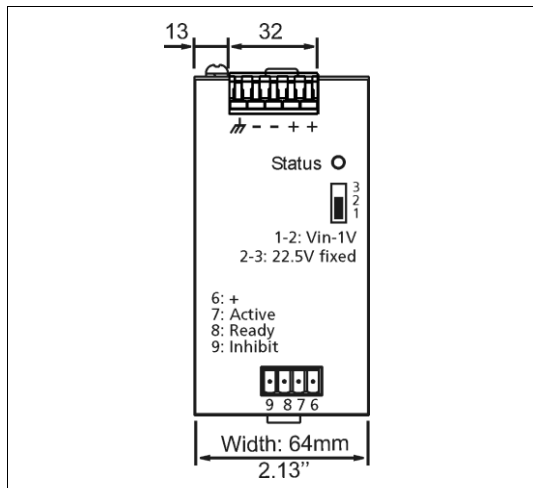
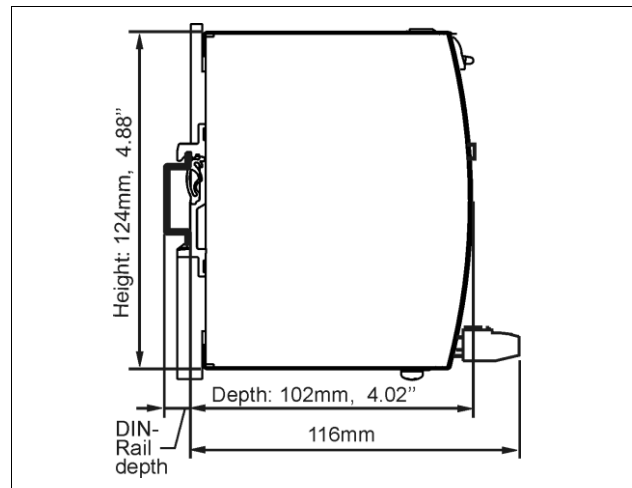

Fig. 23-2 Side view



### 24. ACCESSORIES

#### 24.1. ZM1.WALL - WALL MOUNTING BRACKET



This bracket is used to mount the buffer module on a wall without utilizing a DIN-Rail.

The two aluminum brackets and the black plastic slider of the unit have to be detached, so that the steel brackets can be mounted.

Fig. 24-1 Wall mounting

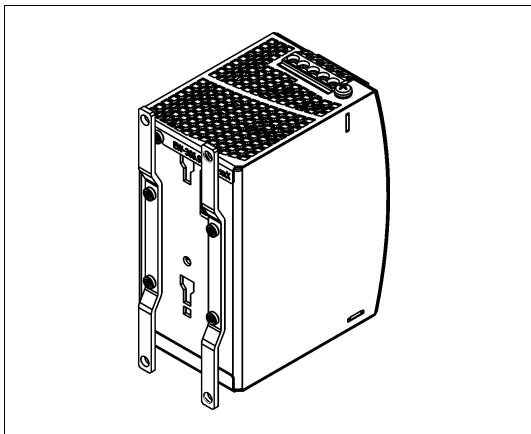
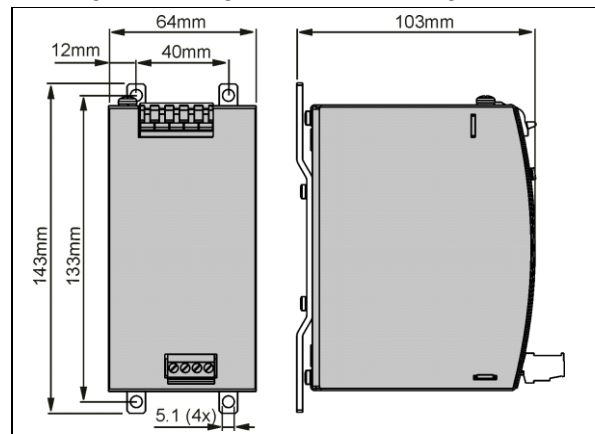

Fig. 24-2 Mounting Dimensions - Wall mounting bracket





### 24.2. ZM14.SIDE - SIDE MOUNTING BRACKET



This bracket is used to mount the buffer module sideways with or without utilizing a DIN-Rail.  
 The two aluminum brackets and the black plastic slider of the unit have to be detached, so that the steel brackets can be mounted.  
 For sideways DIN-rail mounting, the removed aluminum brackets and the black plastic slider need to be mounted on the steel bracket.

Fig. 24-3  
Side mounting without DIN-rail brackets

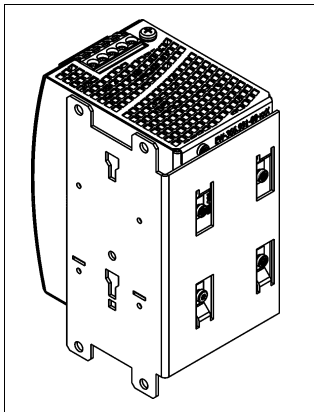

Fig. 24-4  
Side mounting with DIN-rail brackets

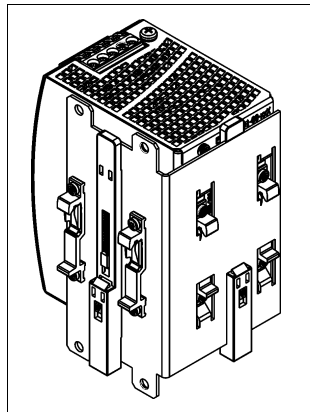
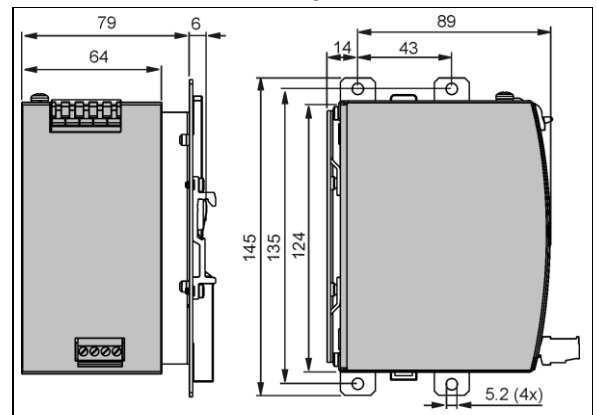

Fig. 24-5  
Mounting Dimensions  
Side mounting bracket



### 25. WIRING DIAGRAMS

Fig. 25-1 General wiring diagram

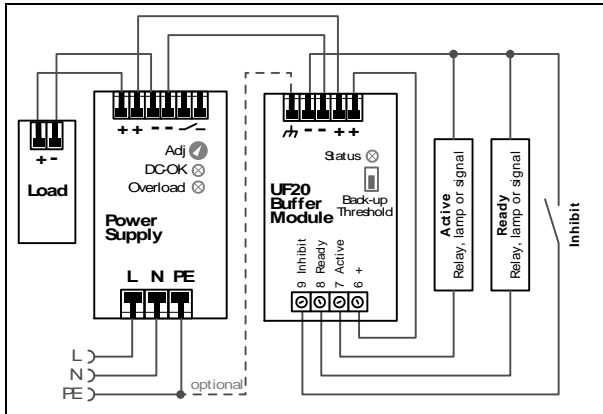

Fig. 25-2 Signals supplied from an external voltage source

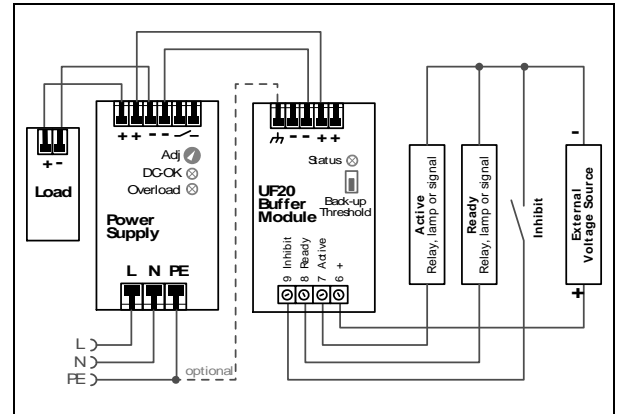

Fig. 25-3 Paralleling of buffer modules

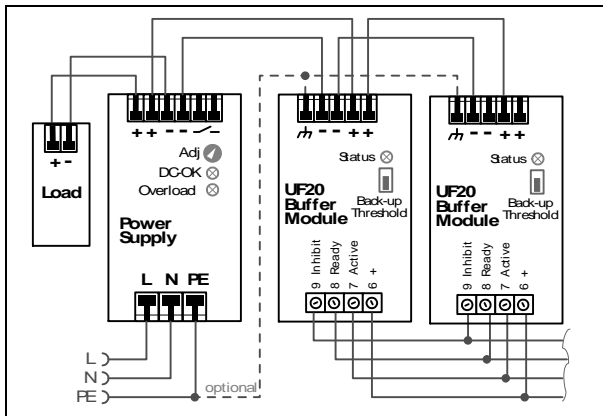

Fig. 25-4 Decoupling of buffered branches

