

Mipco™ Connections for Refrigerated Containers

Plug Into Mipco™ Power

Mipco™ plugs, connectors and receptacles are used extensively in ports, terminals, transport and shipboard applications to provide a safe, watertight electrical connection for refrigerated containers. Mipco™ construction and design benefits are a quality benchmark:

- **No corrosion:** Aluminum receptacles are copper-free aluminum castings with a unique two-layer electrostatic epoxy powder-coat finish. Stainless steel and brass components are used extensively.
- **Tougher and better:** Thermoplastic receptacle, connectors and plugs are made from AMTUF™ high-abuse Nylon thermoplastic and DuraV® high-strength thermoplastic. Wide range chemical, UV withstand, impact and overall performance characteristics set the standard for construction.
- **Safety Listed and Approved:** We lead with safety in UL/CSA listings, approvals and certifications. “Recognized” or “non-listed” offshore supplier components just aren’t the same.



The Mipco™ Advantage

Safety

- Safety ground pin “makes first”, “breaks last” for optimum operator safety
- Internal O-ring seals provide watertight integrity, even without plug engaged or cap in place
- Thermoset interiors provide the safest insulation under extreme conditions
- Color-coded housings provide easy identification of mating components

Durability

- AMTUF™ housings provide three times the impact and temperature resistance of polycarbonate. Extremely resistant to oil, fuel, grease and most common solvents
- Neoprene cable compression bushings with locking collars provide a watertight, tug-proof connection

Reliability

- Solid brass contact sleeves with beryllium copper compression springs minimize heat rise and corrosion
- Waterproof cable sealings and locking screw collars ensure waterproof connections

Easy Installation & Service

- Fast assembly and wiring with “drop-in” rear loaded interiors
- A variety of optional bushing sizes available for plugs and connectors to ensure sealing to your cable
- Readily available service parts:
 - Interior assemblies
 - Gland nut assemblies
 - Screw collars
 - Flap cap/screw cap assemblies

Mipco™ Connections for Refrigerated Containers

Waterproof Cable Sealing:

- Nut with cable locking clamps
- Neoprene compression bushing cable sealing/locking system

Fast, Easy, Rear Load Wiring & Assembly:

- Terminal set screws

The Most Durable Materials Available

- AMTUF™ high-impact housings
- Thermoset interiors

Waterproof Locking Connections:

- Locking screw collars with gasket seals
- IP67 minimum

Dry Wiring Compartments

- Interior O-ring seals around compartments, and each pin and sleeve ensure waterproof connections

High Reliability, High-Performance Connections

- CDA 360 solid brass pin & sleeve
- Ground contacts “makes first”, “breaks last”

Long-Lasting, Self-Cleaning Connections

- Full round pin & sleeve contacts for maximum contact area and coolest connection

Dry Wiring Compartments

- Interior O-ring seals around compartments, and each pin and sleeve ensure true “waterproof connections”

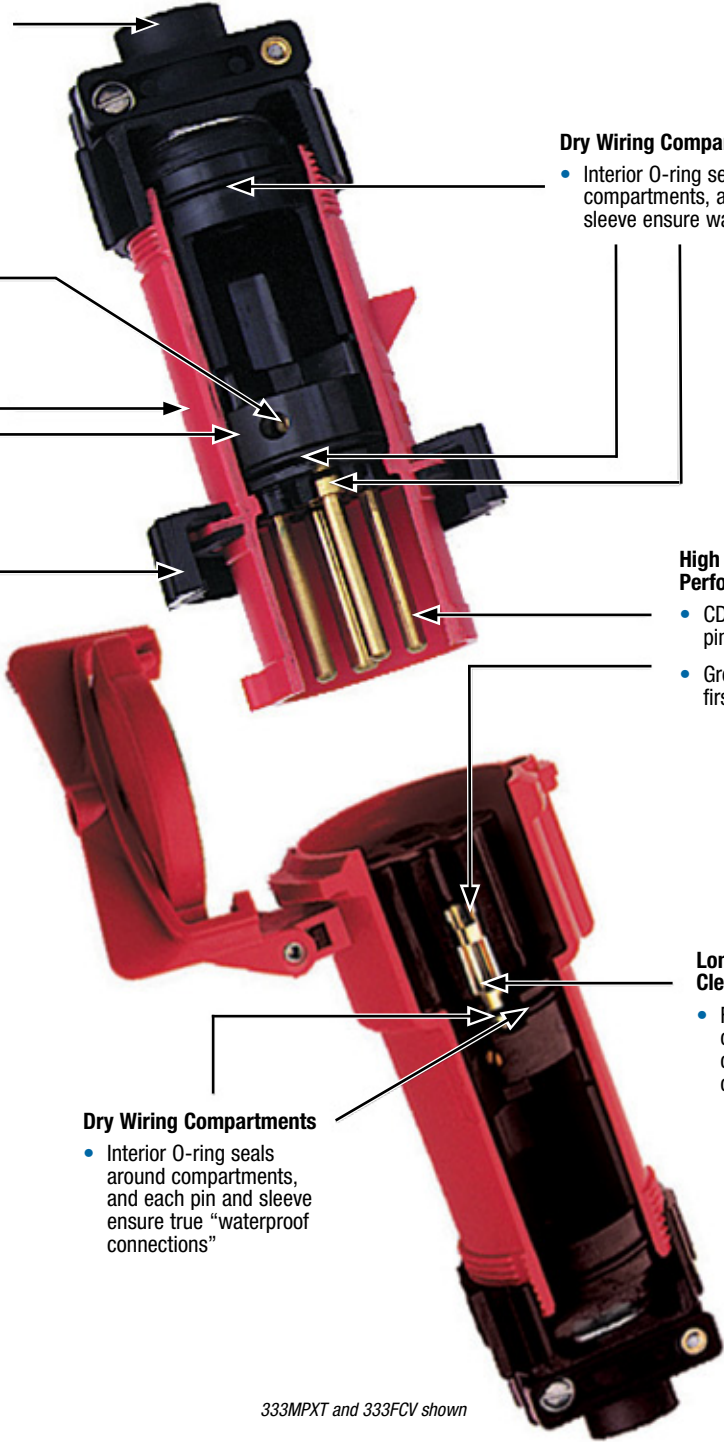

333MPXT and 333FCV shown