



**Safety Technology
International**

UB-2PN Universal 2” Pneumatic Button



**ADA
Compliant**

We protect the things that protect you.®

NOTES

It is important to read, understand and follow all instructions provided with this product. It is the installer's responsibility to comply with NFPA 70 & 101, NEC, mounting specifications according to ADA and other applicable electrical codes. This switch is rated Type NM (Non-Monitored) for non-emergency signaling. Not to be used in place of panic hardware. To avoid electrical shock, DO NOT attempt to install this product when power is on. ADA mounting compliance requires the operable part of the initiating device shall not be less than 3 1/2 ft. (1.1m) or greater than 4 1/2 ft. (1.37m) above finished floor surface. After installation and testing are complete, provide a copy of this manual to all personnel responsible for testing and maintenance of this product.

* For access control installations, power for the UB-2PN must be supplied by a power source Listed to UL294. When used for access control, this device shall be used as a part of an access controlled egress door system. It is up to the local AHJ to allow use of this device in place of an automatic sensor. For higher security installations, lower time limits should be used.

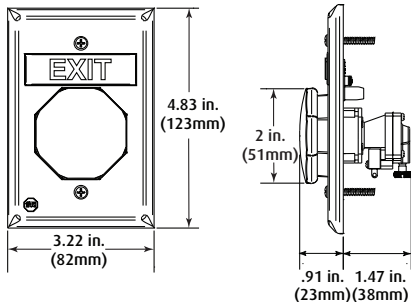

SWITCH RATING

Independent Form "Z" contacts

Rated at: 10A @ 240 VAC

Operating Temp: 15° to 120°F (-9° to 49°C)

1,000,000 Cycles

1. TO CHANGE BUTTON COLOR AND ROUND MESSAGE

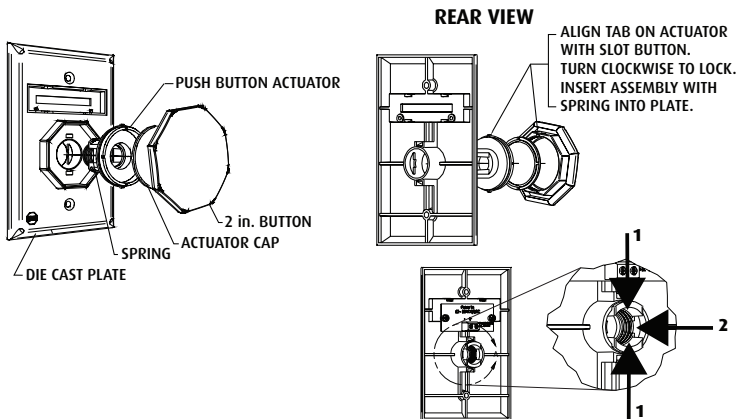

1. Choose button message and color. If same as existing, proceed to **2**.
2. To remove push button actuator assembly, squeeze actuator tabs in direction of #1 arrows.
3. Push actuator through plate in direction of #2 arrow.
4. Align actuator cap to push button actuator. Align button slots to tabs on push button actuator.
5. Snap button onto push button actuator and rotate right to lock.
6. Insert spring into push button actuator.
7. Squeeze legs of push button actuator and align into die cast plate.

2. CHANGE TOP MESSAGE

1. Remove LED circuit board.
2. Remove current message by pushing in and down on tabs 1 and 2 with a small screwdriver. If necessary, also push in and down on tabs 3 and 4. Once message is loose, remove from the front of the plate.
3. Select new message and snap into place. Blank plates are included to create your own custom message.

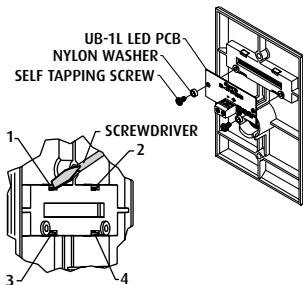

3. INSTALL OR REMOVE CONTACT BLOCK

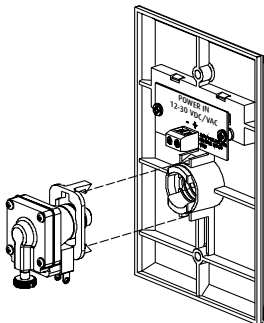

INSTALL

To attach, align tabs (as shown) and gently snap **top, then bottom**. Be sure to hear **BOTH** tabs snap into place. Contacts can be rotated 180° if desired.

CONTACT INFORMATION

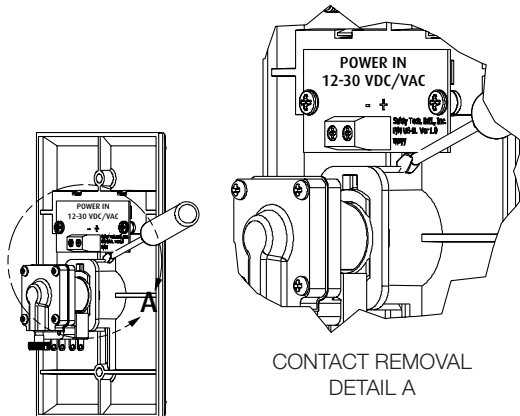

REMOVE

To remove, use a small flat blade screwdriver. Position screwdriver blade under tab and gently rotate screwdriver until tab disengages. Repeat for opposite tab.

4. ATTACH POWER FOR MESSAGE LED (if desired - see drawing)

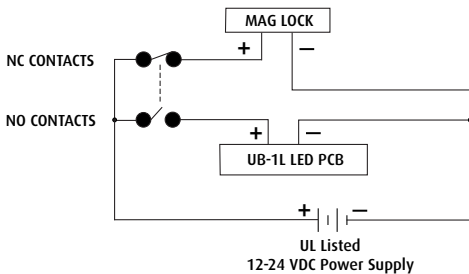

	<u>NORMAL POSITION</u>	<u>BUTTON ACTIVATED</u>
MAGNETIC LOCK	ON	OFF
MESSAGE LAMP	OFF	ON

CONTACT DIAGRAM

CONNECTION AND LEAD WIRE COLOR CODE

(BLACK) NC
(RED) NO

NC (GREEN)
NO (WHITE)

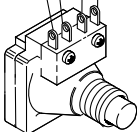

CONTACTS

One set NO and one set NC

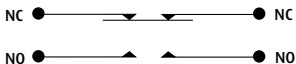

SWITCH INFORMATION

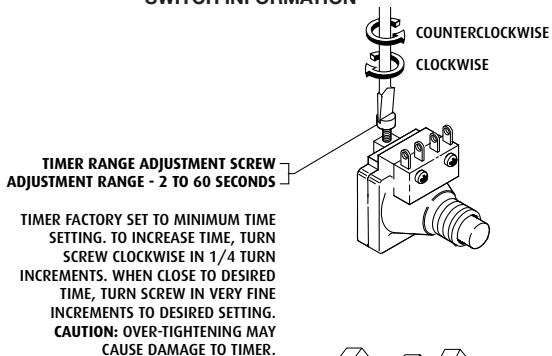

5. MOUNT BUTTON ONTO ELECTRICAL BOX

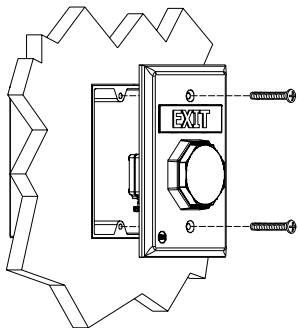

6. CUSTOM LABELS

To create your own custom label, size to fit in .48h x 2.23w as shown below.

Also available online at: www.sti-usa.com/ublabel

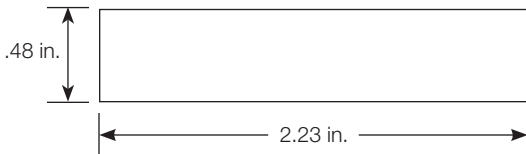

ACCESSORIES

DESCRIPTION	PART #
COLOR MATCH BACK BOX KIT	KIT-71100A-*
	* (R=red, B=blue, G=green, W=white or Y=yellow)
CUSTOM LABEL APPLIED TO BLANK MESSAGE PLATES	UB-1CL-*
2" LENS KIT FOR UNIVERSAL BUTTON	* (B=blue, G=green, W=white or Y=yellow)
CONTACT ASSEMBLY FOR UB-1	UB-2LENS KIT-UB-1C
<u>COVERS</u>	
BOPPER STOPPER	STI-6518
UNIVERSAL STOPPER	STI-13000 Series
STOPPER II®	STI-1100 Series
- See website for complete cover details -	

WARRANTY

Three year guarantee against breakage of polycarbonate in normal use (one year on electro mechanical and electronic components).

 **WARNING:** This product can expose you to chemicals including Dichloromethane, which is known to the State of California to cause cancer, and Bisphenol A (BPA), which is known to the State of California to cause birth defects or other reproductive harm. For more information go to **www.P65Warnings.ca.gov**.



**Safety Technology
International**