

3

Contactors

C195 Series

Single pole
compact universal NO
and changeover contactors

Catalogue B195.en



More information
schaltbau.com

C195 Series Single pole NO and changeover contactors plus bidirectional variants

Compact universal contactors for battery voltages up to 220 V and high voltages up to 1,500 V

Being of compact size and featuring double-break contacts that are covered for the most part, the C195 Series contactors provide high-performance current breaking. Depending on the version you choose C195 series contactors come with blowouts and/or arc chutes.

The coils are fitted as standard with varistors for limiting surge voltages. For coil terminal connections you do *not* need to observe polarity.

With the C195 X there is also a *bidirectional* version, for which the direction of the current is irrelevant, as required for battery storage systems of public utilities. And with 320 A, the C195 X is also characterised by a higher current-carrying capacity.

In addition to that, there is the option of a SPDT version of the C195 series contactor which has an added galvanically isolated NC contact.

Features

- Compact universal contactors up to 1,500 V
- Unidirectional, bidirectional and latching contactor variants
- Broad range of possible applications
- Suitable for years of continuous operation
- Intended for high ambient temperatures
- Double-break contacts that are covered for the most part
- Versions for AC and DC operation available
- DC versions coming with magnetic blowout
- Extended coil tolerance according to railway standard

Applications

C195 series

The contactors are typically used:

- for traffic engineering equipment, particularly in heating circuits and for air conditioning (HVAC equipment)
- as line contactor in mainline AC and DC rail networks – or in combination with a precharging contactor for a host of applications in trains, multiple units, rail cars and light rail vehicles
- for central inverters of complex power supplies
- for battery storage systems of utilities, specifically in grid stabilisation where bidirectional switching is a requirement

Ordering code

C195 series

Example: **C195 A/ 24EV-U2**

Series	C195	Single pole universal contactor	Aux. contacts*2: # of, type	U1
Main contacts: type, nominal voltage U_n	X/	NO contactor with blowouts and arc chamber, $U_n = 1,500$ V	2x snap-action switches S870 W1D1a 012, silver contacts	U2
	A/ *1	NO contactor with blowouts and arc chamber, $U_n = 1,000$ V DC	2x snap-action switches S870 W1D1a 012, silver contacts	I2
	B/	NO contactor with arc chamber, $U_n = 1,000$ V AC	2x snap-action switches S870 W1D4a 012, gold contacts	
	S/ *1	NO contactor, $U_n = 220$ V DC		
	T/	NO contactor, $U_n = 220$ V AC		
	W/	Changeover (SPDT) contactor, $U_n = 220$ V DC		
Coil voltages	24 / 36 / 48 / 60 / 72 / 80 / 96 / 110 V DC		Coil suppression	
			Diode	D
			Varistor	V
			Coil tolerance	
			-30 % ... +25 %	E
			-40 % ... 0 %	J
			Latching contactor -30 % ... +25 %	B

*1 Available as bistable version

*2 2x snap-action switches: versions X/, A/, B/, S/, T/;
1x snap-action switch: versions A/ ...BD, S/ ...BD;
0x snap-action switch: version W/
For detailed information see catalogue D70 on S870 Series snap-action switches



Notice:

Presented in this catalogue are only stock items which can be supplied in short delivery time. For some variants minimum quantities apply. Please do not hesitate to ask for conditions.

Special variants:

If you need a special variant of the contactor, please do not hesitate to contact us. Maybe the type of contactor you are looking for is among our many special designs. If not, we can also supply customized designs.

Standards

C195 series

Industry standards:

- **IEC 60947-1:2014** Low-voltage switchgear and controlgear – Part 1: General rules
- **IEC 60947-4-1:2012** Low-voltage switchgear and controlgear – Part 4-1: Contactors and motor starters - Electromechanical contactors and motor starters.

Railway standards:

- **DIN EN 60077-1:2003-04** Railway applications – Electric equipment for rolling stock – Part 1: General service conditions and general rules.
- **DIN EN 60077-2:2003-04** Railway applications – Electric equipment for rolling stock – Part 2: Electrotechnical components; General rules

Specifications

C195 series

C195 Series, versions	X/	A/	B/	S/	T/	W/	
Main contacts							
Type of voltage	AC, DC bidirectional	DC unidirectional	AC	DC unidirectional	AC	DC unidirectional	
Number of, type	1x NO	1x NO	1x NO	1x NO	1x NO	1x SPDT	
Bistable contactor, optional	---	●	---	●	---	---	
Nominal voltage U_n	1,500 V	1,000 V	1,000 V	220 V	220 V	220 V	
Rated insulation voltage U_i	1,800 V	1,200 V	1,200 V	1,200 V	1,200 V	600 V	
Rtd impulse withstand voltage U_{imp}	10 kV	8 kV	8 kV	8 kV	8 kV	6 kV	
Overtoltage category	OV3	OV3	OV3	OV3	OV3	OV3	
Pollution degree	PD3	PD3	PD3	PD3	PD3	PD3	
Conventional thermal current I_{th}							
	NO	320 A	250 A	250 A	250 A	250 A	
	NC	---	---	---	---	160 A	
Short time (3 minutes) @ $T_a = 50^\circ\text{C}$							
	NO	550 A	450 A	450 A	450 A	450 A	
	NC	---	---	---	---	250 A	
Making capacity							
(resistive, $T = 0$ ms),	NO	1,800 A	1,800 A	1,800 A	1,800 A	1,500 A	
(inductive, $T > 5$ ms),	NO	2,300 A	2,300 A	2,300 A	2,300 A	2,000 A	
(resistive, $T = 0$ ms),	NC	---	---	---	---	250 A	
(inductive, $T > 5$ ms),	NC	---	---	---	---	300 A	
Breaking capacity (at rated operating voltage)							
	NO	950 V DC, T = 1 ms: 320 A T = 15 ms: 40 A	950 V DC, T = 1 ms: 240 A T = 15 ms: 40 A	1,200 V AC, 50 Hz $\cos\phi = 1.0$: 210 A 1,200 V AC, 50 Hz $\cos\phi = 0.8$: 150 A	220 V DC, T = 0 ms: 2,000 A T = 15 ms: 1,000 A	220 V AC, 50 Hz $\cos\phi = 1.0$: 1,500 A	220 V DC, T = 0 ms: 1,500 A T = 15 ms: 700 A
	NC	---	---	---	---	---	220 V DC, T = 0 ms: 250 A T = 15 ms: 100 A
Short-circuit current							
	NO	2,300 A	2,300 A	2,300 A	2,300 A	2,300 A	2,300 A
	NC	---	---	---	---	---	1,000 A
Arc chamber for DC	●	●	---	---	---	---	---
Magnetic blowout	●	●	---	●	---	●	●
Arc chamber for AC	●	---	●	---	---	---	---
Contact material	AgSnO ₂	AgSnO ₂					
Terminals	M8 screw	M8 screw					
Torque	10 Nm max.	NO: 12 Nm max. / NC: 6 Nm max.					
Auxiliary switch							
Number of and type	2x snap-action switches S870*2, SPDT silver contacts, optional gold contacts (see catalogue D70)*1						
Utilization category (IEC 60947-5-1)	Silver contacts*3: AC-15: 1.5 A at 230 V AC; DC-13: 0.5 A at 60 V DC or 2.0 A at 24 V DC						
Terminals	Flat tabs 6.3 x 0.8 mm						
Coil							
Coil voltage U_c	24 / 36 / 48 / 60 / 72 / 80 / 96 / 110 V DC						
Coil tolerance	E, B: -30 % ... +25 % at $T_a = 70^\circ\text{C}$ max. / J: -40 % ... 0 % at $T_a = 40^\circ\text{C}$						
Coil power consumption	cold coil approx. 27 W at $U_{s,max}$, $T_a = 20^\circ\text{C}$ / warm coil approx. 13.5 W at $U_{s,max}$, $T_a = 20^\circ\text{C}$						
Coil temperature	155° C at $T_{a,max}$ and $U_{s,max}$						
Coil suppression	Varistor / Diode						
Coil terminals	Flat tabs 6.3 x 0.8 mm						
IP rating (IP code to IEC 60529)	IP00						
Mechanical endurance, operating cycles	> 3m	> 3m / latch: 100.000					
Electrical endurance, operating cycles	250,000 @ $U_e = 750$ V DC, $I_e = 70$ A, $T = 1$ ms	1 million @ $U_e = 750$ V DC, $I_e = 30$ A, $T = 1$ ms			upon request		
Shock / Vibration (IEC 61373)	Category 1, Class B						
Duty cycle	100 %						
Mounting orientation	any, except: do not mount with mounting plate pointing upwards						
Ambient conditions							
Operating temperature T_a	-25° C ... +50° C for industrial applications / -40° C ... +70° C for railway applications*4						
Storage temperature T_L	-40° C ... +80° C						
Weight	3 kg	2 kg / 2.4 kg*5	1.9 kg	1.6 kg	1.6 kg	1.9 kg	



*1 See footnote page 2 *2 1x S870 Series snap-action switch for latching contactors *3 Data for gold contacts upon request *4 -25° C ... +70° C for latch versions *5 latch versions

C195 X/ Single pole NO AC / DC contactor, bidirectional

C195 series

• Dimension diagram

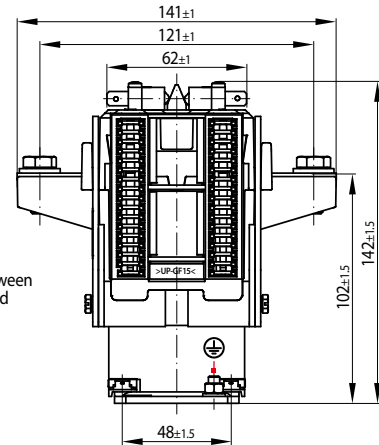
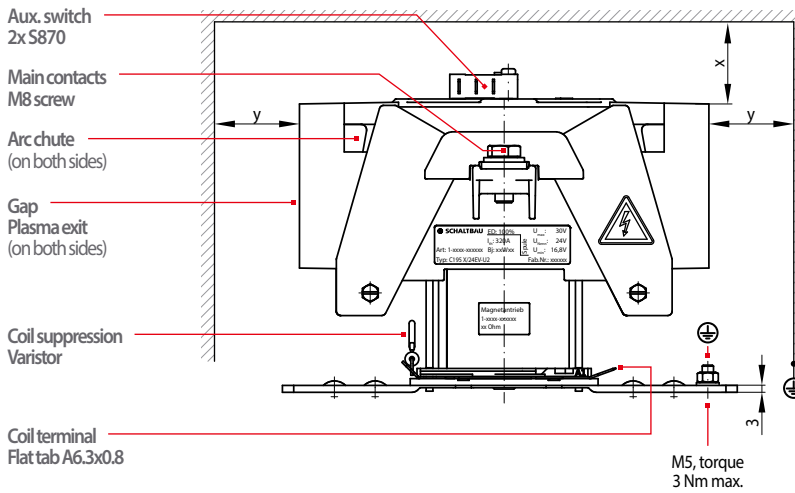

Clearance between plasma exit and earthed parts
x = 40 mm
y = 60 mm

M5, torque 3 Nm max.

• Mounting holes

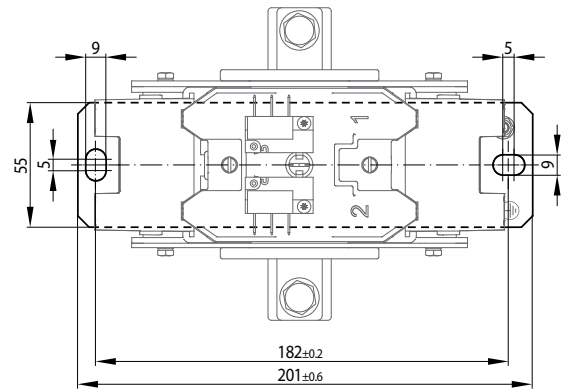

• Circuit diagram

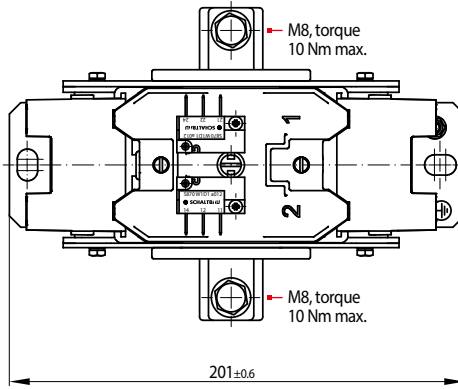
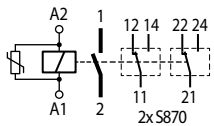

C195 A/ Single pole NO contactor, unidirectional DC

C195 series

• Dimension diagram

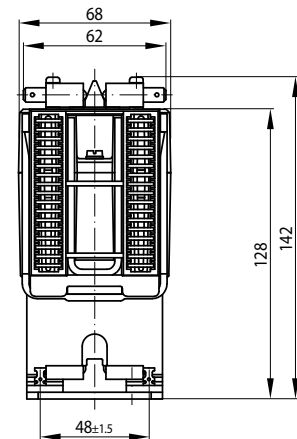
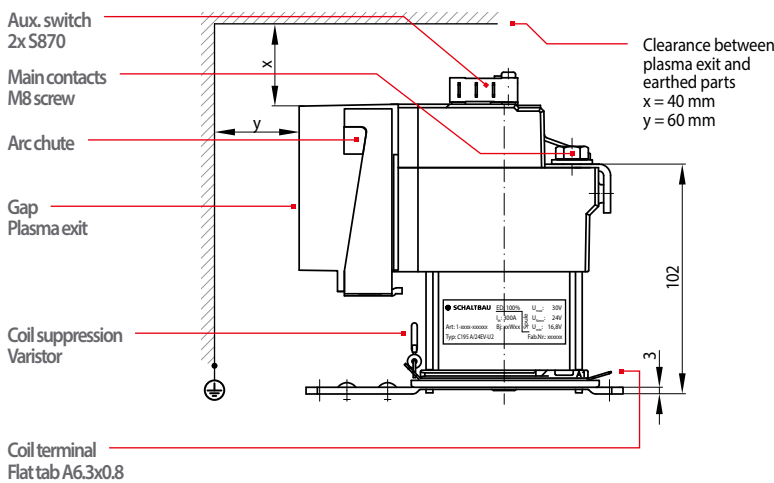

Clearance between plasma exit and earthed parts
x = 40 mm
y = 60 mm

• Circuit diagram

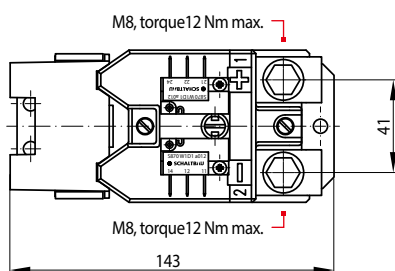
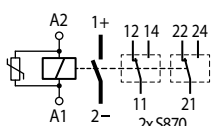

• Mounting holes

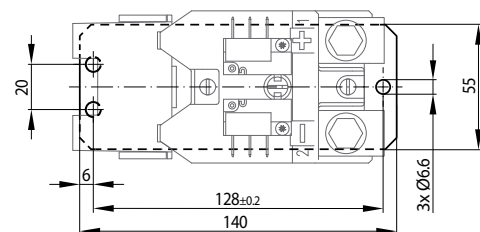

C195 A/ ...BD Single pole NO latching contactor, unidirectional DC

C195 series

• **Dimension diagram**

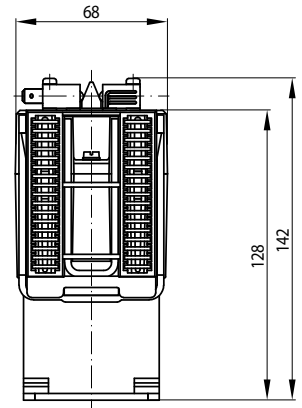
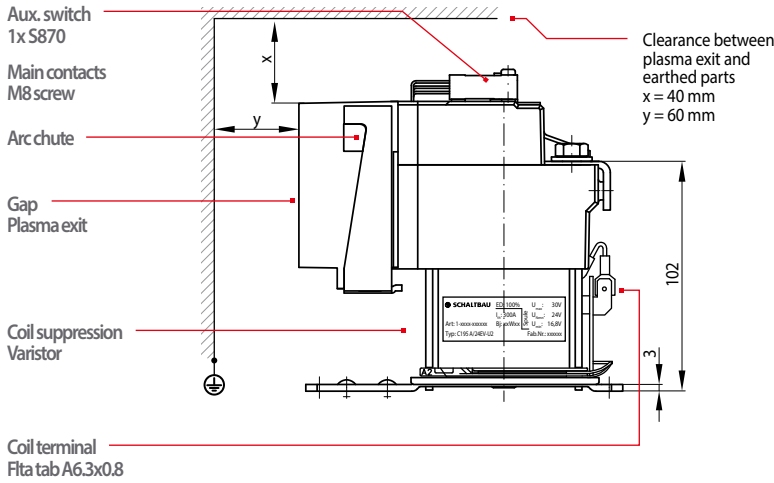

• **Circuit diagram**

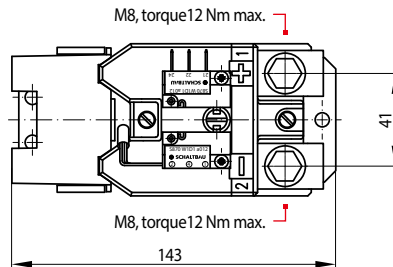
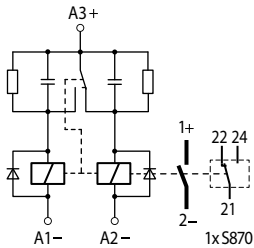

• **Mounting holes**

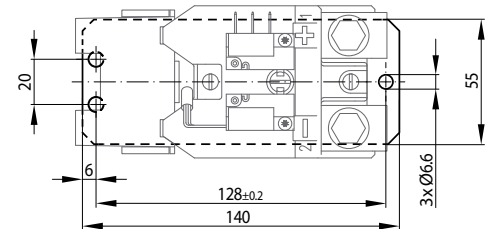

C195 B/ Single pole NO AC contactor

C195 series

• **Dimension diagram**

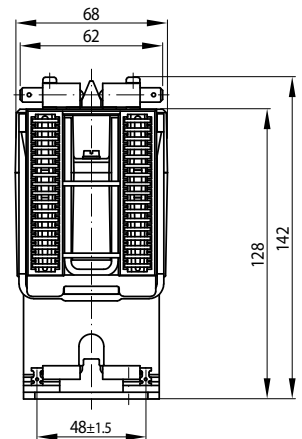
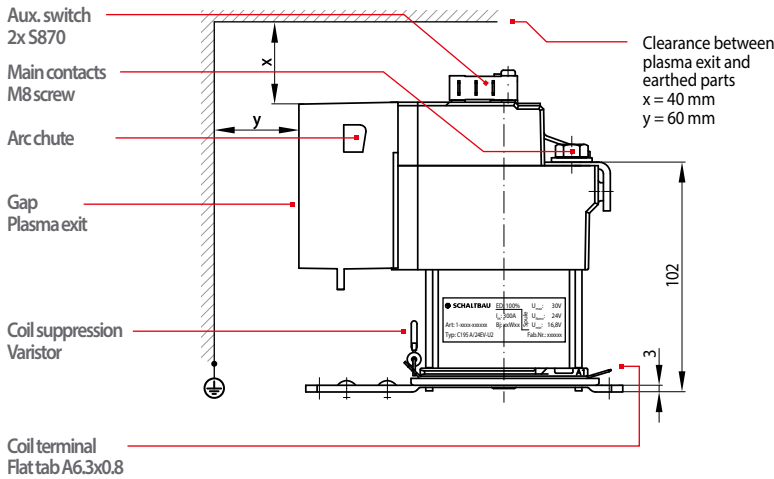

• **Circuit diagram**

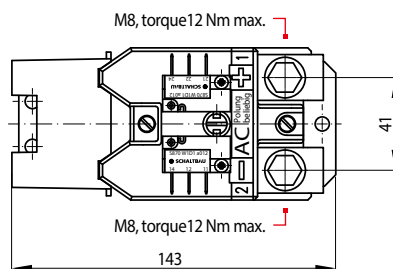
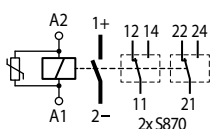

• **Mounting holes**

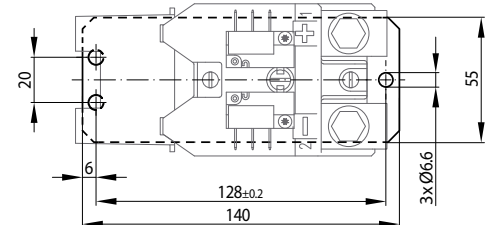

C195 S/ ...BD Single pole NO latching contactor, unidirectional DC

C195 series

• Dimension diagram

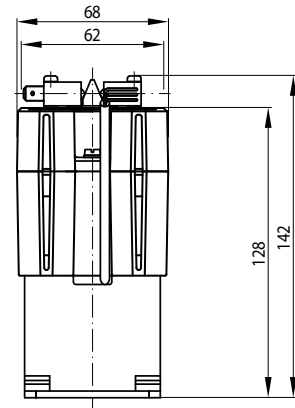
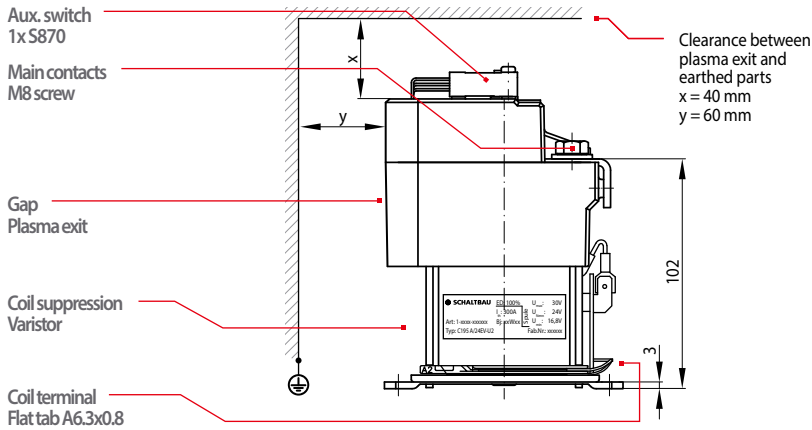

• Circuit diagram

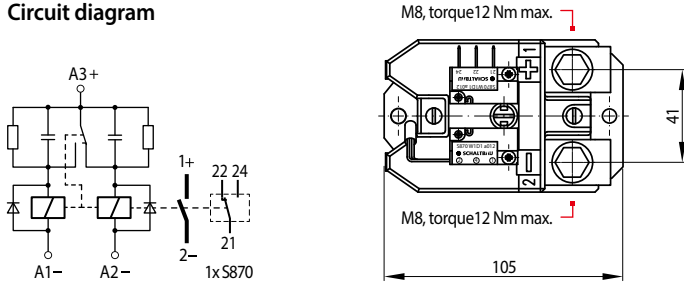

• Mounting holes

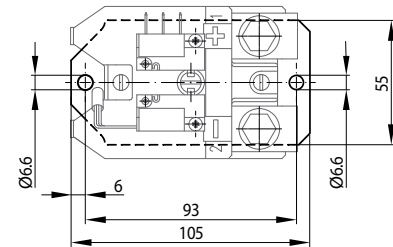

C195 W/ Single pole changeover (SPDT) contactor, unidirectional DC

C195 series

• Dimension diagram

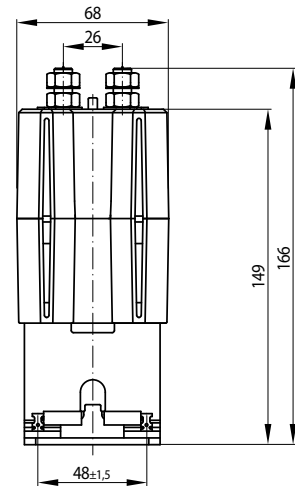
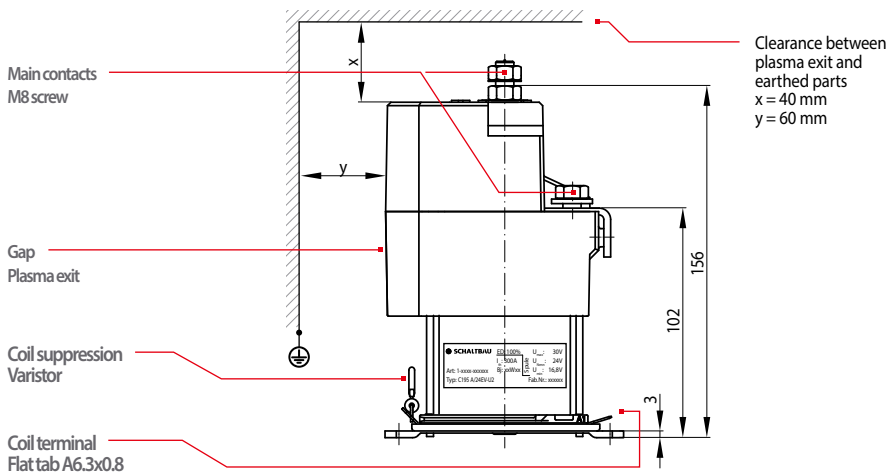

• Circuit diagram

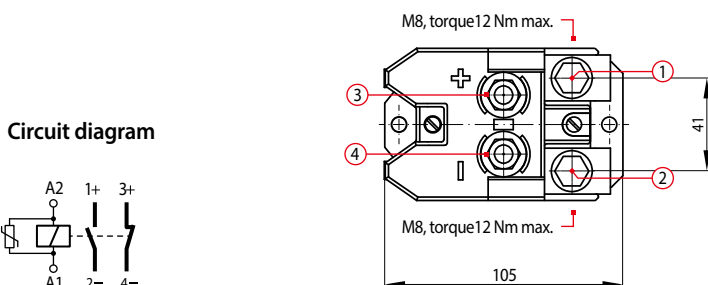

• Mounting holes

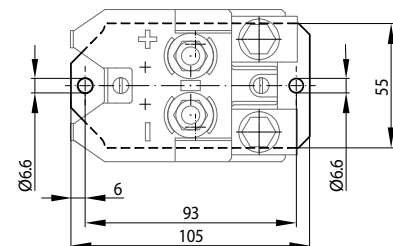

C195 S/, C195 T/ Single pole NO DC / AC contactor, unidirectional

C195 series

• **Dimension diagram**

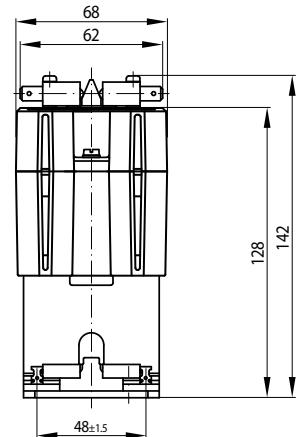
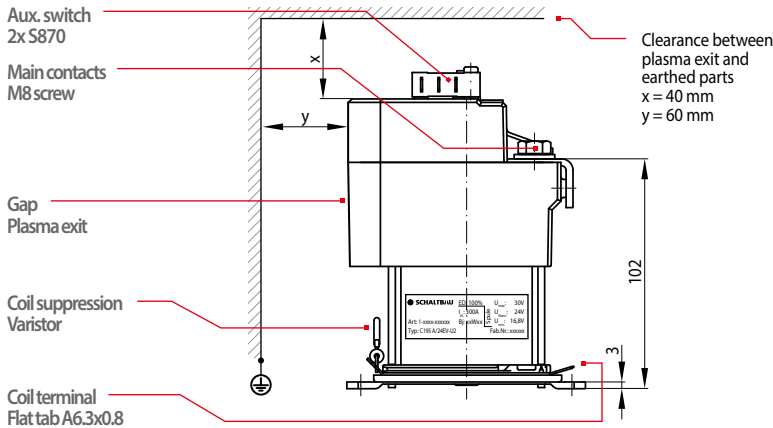

• **C195 S/** version for DC

Circuit diagram

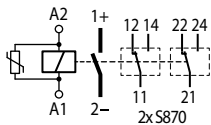

M8, torque 12 Nm max.

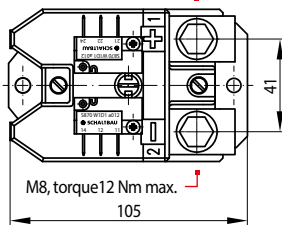

• **Mounting holes**

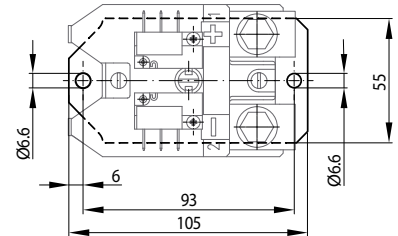

• **C195 T/** version for AC

Circuit diagram

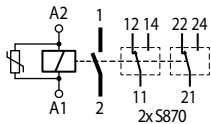

M8, torque 12 Nm max.

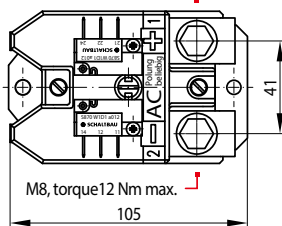

Mounting orientation, Maintenance

• **Possible mounting orientations:**

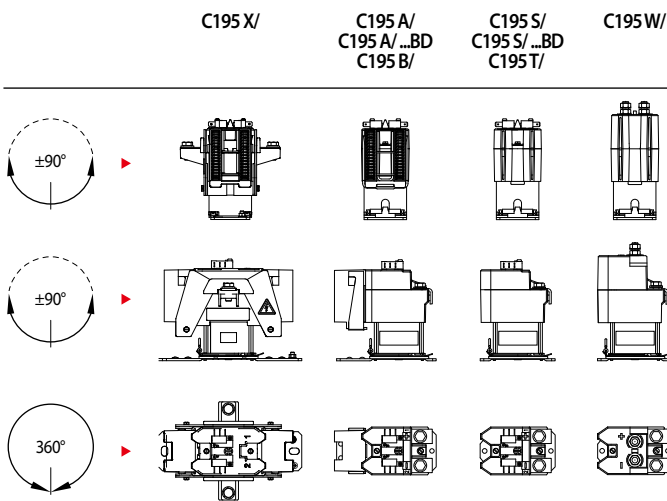

• **Maintenance**

Safety instructions

C195 series

- The device must be used according to the intended purpose as specified in the technical documentation. You are obliged to observe all specifications depending on operating temperature, degree of pollution etc. that are relevant to your application.
- Contactors are only suitable for use in cable cars and lifts with separate safety consideration by the system integrator.
- Without further safety measures the contactors are not suited for use in potentially explosive atmospheres.
- In case of malfunction of the device or uncertainties stop using it any longer and contact the manufacturer instantly.
- Tampering with the device can seriously affect the safety of people and equipment. This is not permitted and leads to an exclusion of liability and warranty.
- Coil suppression for reducing surges when the coil is switched off is optimally attuned to the contactors switching behaviour. The existing opening characteristic must not be negatively influenced by parallel connection with an external diode.
- Contactors running permanently may heat up. So make sure that the contactor has sufficiently cooled down before you start any inspection or maintenance work.
- When installing contactors with magnetic blowout make sure to do it in such a way that no magnetizable parts can be attracted by the permanent magnets that are also capable of destroying all data of swipe cards.
- Strong electromagnetic induction caused when switching off can influence other components installed near the contactor.
- Improper handling of the contactor, e.g. when hitting the floor with some impact, can result in breakage, visible cracks and deformation.



For detailed instructions on safety, maintenance and mounting refer to our manual 195-M.en!



Defective parts must be replaced immediately!

Schaltbau GmbH

For detailed information on our products and services visit our website – or give us a call!

Schaltbau GmbH
Hollerithstrasse 5
81829 Munich
Germany



Phone +49 89 9 30 05-0
Fax +49 89 9 30 05-350
Internet www.schaltbau.com
e-Mail contact@schaltbau.de



The production facilities of Schaltbau GmbH have been IRIS certified since 2008.



Certified to DIN EN ISO 14001 since 2002. For the most recent certificate visit our website.



Certified to DIN EN ISO 9001 since 1994. For the most recent certificate visit our website.

Electrical Components and Systems for Railway Engineering and Industrial Applications

Connectors

- Connectors manufactured to industry standards
- Connectors to suit the special requirements of communications engineering (MIL connectors)
- Charging connectors for battery-powered machines and systems
- Connectors for railway engineering, including UIC connectors
- Special connectors to suit customer requirements

Snap-action switches

- Snap-action switches with positive opening operation
- Snap-action switches with self-cleaning contacts
- Snap-action switch made of robust polyetherimide (PEI)
- Snap-action switch with two galvanically isolated contact bridges
- Special switches to suit customer requirements

Contactors Emergency disconnect switches

- Single and multi-pole DC contactors
- High-voltage AC/DC contactors
- Contactors for battery powered vehicles and power supplies
- Contactors for railway applications
- Terminal bolts and fuse holders
- DC emergency disconnect switches
- Special contactors to suit customer requirements

Electrics for rolling stock

- Equipment for driver's cab
- Equipment for passenger use
- High-voltage switchgear
- High-voltage heaters
- High-voltage roof equipment
- Equipment for electric brakes
- Design and engineering of train electrics to customer requirements

We reserve the right to make technical alterations without prior notice.

For updated product information visit www.schaltbau-gmbh.com.

Issued 03-2023