

**Pneumatic Actuator Valve Linkage Kit
General Instructions****Application**

The AV-400 valve linkage kit is used to field assemble MK-2690 pneumatic actuators to a variety of 1/2" through 2" valve bodies.

Features

- Springs are provided for all control signal applications, including 3 to 7, 5 to 10, and 8 to 13 psig.
- Kit fits both current and obsolete TAC Barber-Colman valve bodies.

Applicable Literature

- Environmental Controls Cross-Reference Guide, F-23638
- Environmental Controls Reference Manual, F-21683
- Environmental Controls Application Manual, F-21335
- Pneumatic Products Catalog F-27383
- MK-2690, Pneumatic Valve Actuator General Instructions, F-13893
- Valve Selection Guide, F-26094
- EN-205 Water System Guidelines, F-26080

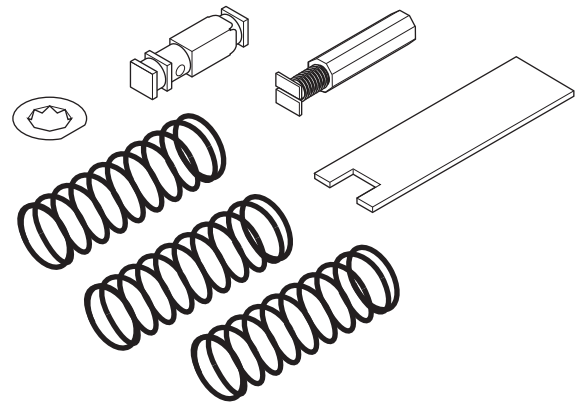

INSTALLATION

Inspection

Inspect the package for damage. If damaged, notify the appropriate carrier immediately. If undamaged, open the package and inspect the device for obvious damage. Return any damaged products.

Requirements

- Tools (not provided):
 - Screwdriver appropriate for slotted spring compression screw
 - Two 3/8" wrenches
 - TOOL-20-1, Packing and linkage wrench
 - TOOL-19, Spring compression tool
- Linkage wrench (provided)
- Training:
 - Installer must be a qualified, experienced technician

▼ CAUTION

- Avoid locations where excessive moisture, corrosive fumes, or vibration are present. Do not insulate piping above the actuator mounting nut preventing proper drainage.
 - Install all two-way valves so that they close against the flow. An arrow on the valve body or a tag indicates the proper flow direction.
 - Always install three-way mixing valves with two inlets and one outlet.
 - Always install three-way diverting valves with one inlet and two outlets.
 - Do not install the actuator below the center line of the valve. For steam applications mount the actuators above the valve body at 45° from vertical.
-

Mounting

1. Actuators can be mounted in any upright position above the centerline of a valve body.
2. When selecting a location, allow sufficient room for accessories and for service of the product.
3. Maintain proper flow direction when installing all globe and radiator-type valves. Flow direction is indicated by an arrow on the valve body or by information on the attached tag.

ASSEMBLY PROCEDURE

The AV-400 linkage kit contains parts for installation on both current 1/2" to 1-1/4" VB-7xxx series valve bodies and on obsolete 1/2" to 1-1/4" VB-9xxx and older valve bodies.

AV-400 Valve Linkage Kit Used with VB-7xxx Series Valves

The AV-400 linkage kit used with the MK-2690 actuator on VB-7xxx series valve bodies require no stem height setting. Follow the assembly procedure for VB-7xxx series valves on pages 6 through 8 for the selected valve body. Refer to **Environmental Controls Valve Selection Guide, F-26094**, or **Environmental Controls Catalog, F-25683**, for valves accommodating the MK-2690 actuator and AV-400 linkage kit.

▼ CAUTION

- It is essential that the proper parts be used for the valve body on which the linkage is being installed to ensure proper actuator operation and close off.
- Do not attempt to use the square stem extension with VB-7xxx valves. Parts or valves may be damaged internally.

Linkage Kit Installation

The linkage is assembled onto the VB-7xxx valve body with stem in the up position.

1. Thread the hexagon coupler onto the valve stem all the way to the bottom of the stem thread, finger tight (Figure-1).

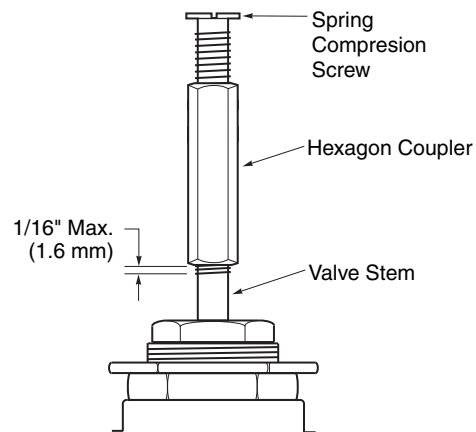

Figure-1 Installation of Hexagon Coupler and Spring Compression Screw onto Valve Stem.

▼ CAUTION

The hexagon coupler must reach to within 1/16" (1.6 mm) of the smooth section of the stem to assure proper seating.

2. Start the spring compression screw one turn or more into the hexagon coupler. Pull the valve stem completely up (Figure-2).

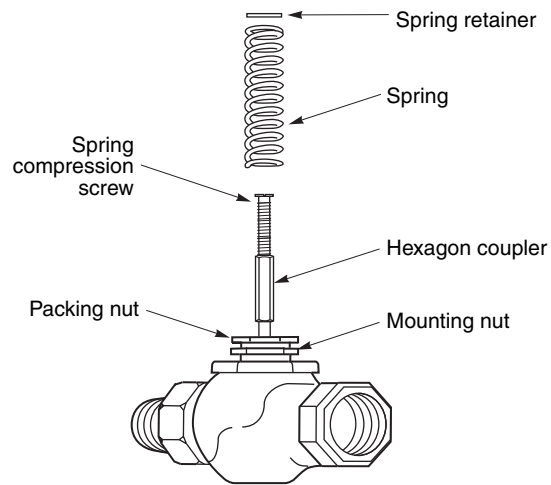

Figure-2 Assembly of AV-400 Linkage Kit onto VB-7xxx Series Valve.

3. Choose the correct spring for the desired actuator operating pressure range:

3 to 7 psig (21 to 48 kPa)	Yellow Spring
5 to 10 psig (34 to 68 kPa)	Black Spring
8 to 13 psig (55 to 89 kPa)	Blue Spring
4. Slip the spring over the coupler and screw.
5. Place the retainer over the screw. Twist the retainer 45° to lock it in place on the spring compression screw.
6. Insert the linkage wrench (supplied with kit, also included on TOOL-20-1) through the spring coils to hold hexagon coupler.
7. Tighten the spring compression screw. To establish proper linkage height, run the spring compression screw down until the screw end bottoms firmly on the stem top (Figure-3).
 - On stem up closed valves (VB-722x) or three-way valves (VB-73xx), you will feel the screw bottom.

- On stem up open valves (VB-721x), the stem and hexagon coupler will begin to turn.

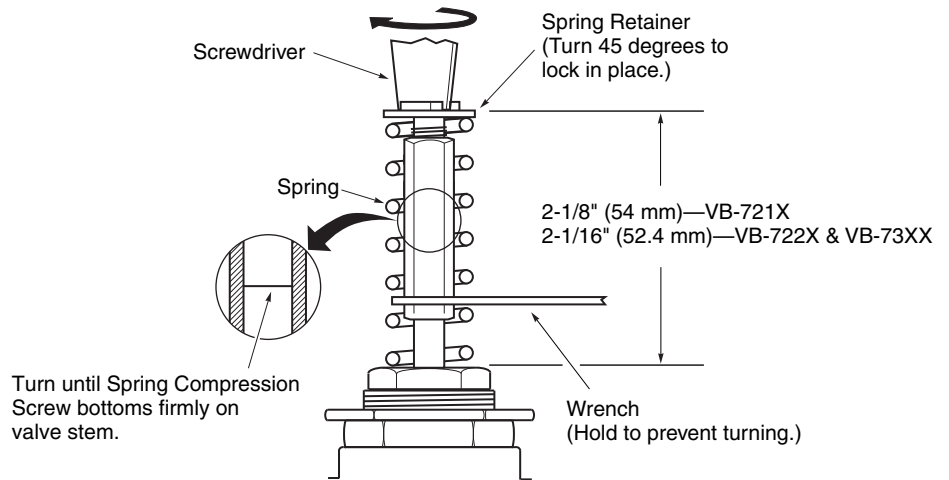

Figure-3 Installation of Linkage Spring.

8. Confirm stem height setting (Figure-3):

2-1/8" (54 mm) maximum after installation on up open valves (VB-721x)

2-1/16" (52 mm) maximum on stem up closed (VB-722x or three-way)

9. Center the spring on top and bottom to assure smooth actuator operation.

10. Install the actuator onto the valve by screwing the actuator base onto the mounting nut (Figure-5). The actuator may be rotated as desired to facilitate making the pneumatic connection.

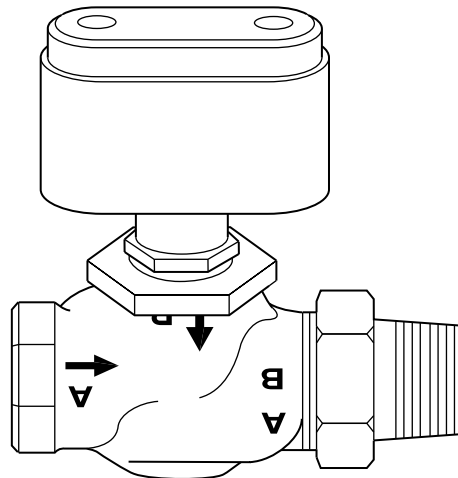

Figure-4 MK-2690 Actuator Mounted on VB-7xxx Valve.

AV-400 Linkage Kit Used with Current VB-121, VB-324, and Obsolete VB-9xxx Series Valves

Refer to the following tables to select compatible valves for the MK-2690 actuator using the AV-400 linkage kit that require stem height settings. Refer to Table-2 for current valves. Table-2 and Table-3 list the obsolete valve bodies used by the MK-2690 actuator and requiring the AV-400 linkage kit. Follow the assembly procedures on pages 8 and 9.

Table-1 Current Valve Selections for the MK-2690 Actuator Using the AV-400 Linkage.

Valve Assembly Number	Normal Position	Spring Range	Valve Body Number Standard, No Linkage			Valve Body Number Assembly with Linkage	Set Stem Height (Dim. "X") in. (mm)
			Angle	Straightway	3-Way	3-Way	
VK-1219-201 VK-1219-202 VK-1219-203	Open	3-7 * 5-10 ** 8-13 ***	—	VB-121-0-4-xx	—	—	1-11/16 (43) Stem Down
VK-3249-201 VK-3249-202 VK-3249-203	Stem Up	3-7 * 5-10 ** 8-13 ***	—	—	VB-324-0-5-04	—	2 (51) Stem Up

* Yellow Spring

** Black Spring

*** Blue Spring

Table-2 Obsolete VB-9xxx Valves, No Longer Available for the MK-2690 Actuator Using the AV-400 Linkage.

Valve Assembly Number	Normal Position	Spring Range	Valve Body Number Standard, No Linkage			Valve Body Number Assembly with Linkage	Set Stem Height (Dim. "X") in. (mm)
			Angle	Straightway	3-Way	3-Way	
VK-1114-201 VK-1114-221	Open	3-7 * 8-13 ***	VB-111-0-3-xx	—	—	—	1-21/32 (42) Stem Down
VK-9211-201 VK-9211-202 VK-9211-203		3-7 * 5-10 ** 8-13 ***	VB-9211-0-4-xx				
VK-9212-201 VK-9212-202 VK-9212-203		3-7 * 5-10 ** 8-13 ***	VB-9212-0-4-xx				
VK-9213-201 VK-9213-202 VK-9213-203		3-7 * 5-10 ** 8-13 ***	VB-9213-0-4-xx				
VK-9214-201 VK-9214-202 VK-9214-203		3-7 * 5-10 ** 8-13 ***	VB-9214-0-4-xx				
VK-9221-201 VK-9221-202 VK-9221-203		3-7 * 5-10 ** 8-13 ***	VB-9221-0-4-Size				
VK-9222-201 VK-9222-202 VK-9222-203		3-7 * 5-10 ** 8-13 ***	VB-9222-0-4-xx				
VK-9223-201 VK-9223-202 VK-9223-203		3-7 * 5-10 ** 8-13 ***	VB-9223-0-4-Size				
VK-9224-201 VK-9224-202 VK-9224-203		3-7 * 5-10 ** 8-13 ***	VB-9224-0-4-Size				
VK-9312-201 VK-9312-202 VK-9312-203		Mixing Stem Up Closes A Port	3-7 * 5-10 ** 8-13 ***	—			
VK-9313-201 VK-9313-202 VK-9313-203	3-7 * 5-10 ** 8-13 ***		VB-9313-0-4-xx		VB-9313-201-4-xx VB-9313-202-4-xx VB-9313-203-4-xx		
VK-9314-201 VK-9314-202 VK-9314-203	3-7 * 5-10 ** 8-13 ***		VB-9314-0-4-xx		—		
VK-9323-201 VK-9323-202	5-10 ** 8-13 ***		VB-9323-0-4-xx		VB-9323-202-4-xx VB-9323-203-4-xx		
VK-9332-203	Stem Up Sequencing	8-13 ***	—	—	VB-9332-0-4-xx	VB-9332-203-4-xx	1-3/4 (44) Stem Down

* Yellow Spring

** Black Spring

*** Blue Spring

Table-3 Valve Bodies Using AV-400 Linkage Kit Obsolete before 1996.

Valve Type	Valve Assembly Number †	Normal Position	Spring Range	Valve Body Number Standard, No Linkage †		Valve Body Number Assembly with Linkage †		Set Stem Height (Dim. "X") in. (mm)	
				Angle	Straightway	Angle	Straightway		
Radiator	VK-1114-201-4	Open	3-7 *	—	VB-111-0-4-x	VB-111-201-3-x	VB-111-201-4-x	1-11/16 (43) Stem Down	
	VK-1114-221-4		8-13 ***			VB-111-221-3-x	VB-111-221-4-x		
Flared 2-Way	VK-1214-201		3-7 *	VB-121-0-3-x	VB-121-0-4-x	VB-121-201-3-x	VB-121-201-4-x		
	VK-1214-221		8-13 ***			VB-121-221-3-x	VB-121-221-4-x		
Inverted Flared 2-Way	VK-1314-201 (N.O.)		3-7 *	VB-131-001-3-x	VB-131-001-4-x	VB-131-201-3-x	VB-131-201-4-x		2 (51) Stem Up
	VK-1314-202 (N.C.)					VB-131-002-3-x	VB-131-002-4-x		
	VK-1314-221 (N.O.)		8-13 ***	VB-131-001-3-x	VB-131-001-4-x	VB-131-221-3-x	VB-131-221-4-x		1-11/16 (43) Stem Down
	VK-1314-222 (N.C.)					VB-131-002-3-x	VB-131-002-4-x		VB-131-222-3-x
Globe Screwed N.C.	VK-1514-201	Closed	3-7 *	—	VB-151-0-1-x	—	VB-151-201-1-x	1-31/32 (50) Stem Up	
	VK-1514-221		8-13 ***				VB-151-221-1-x		
	VK-2454 Obsolete		Replace with VK- 9223 Series				—		
Globe Screwed 3-Way	VK-3144-201	Stem Up	3-7 *	VB-314-0-1-x	VB-314-201-1-x		2 (51) Stem Up		
	VK-3144-211		5-10 **		VB-314-211-1-x				
	VK-3144-221		8-13 ***		VB-314-221-1-x				
Flared 3-Way	VK-3244-201		3-7 *	VB-324-0-5-4	VB-324-201-5-4				
	VK-3244-211		5-10 **		VB-324-211-5-4				
	VK-3244-221		8-13 ***		VB-324-221-5-4				
Inverted Flared 3-Way	VK-3544-201	3-7 *	VB-354-0-5-x	VB-354-201-5-x					
	VK-3544-211	5-10 **		VB-354-211-5-x					
	VK-3544-221	8-13 ***		VB-354-221-5-x					

* Yellow Spring ** Black Spring *** Blue Spring

† No longer available. See the Maintenance Parts Catalog, F-26033 for available maintenance and repair parts.

CAUTION

- It is essential that the proper parts be used for the valve body on which the linkage is being installed to ensure proper actuator operation and close off.
- Do not attempt to use the hexagon coupler with VB-121, VB-324, or VB-9xxx valves. Stroke or close off may be affected.

Linkage Kit Installation

NOTE

Refer to Table-2 for current VB-121 and VB-324 valves to maintain the proper stem height during assembly. Refer to Table-2 for obsolete VB-9xxx valves to maintain the proper stem height during assembly.

1. Thread the square stem extension several turns onto the valve stem (Figure-5).

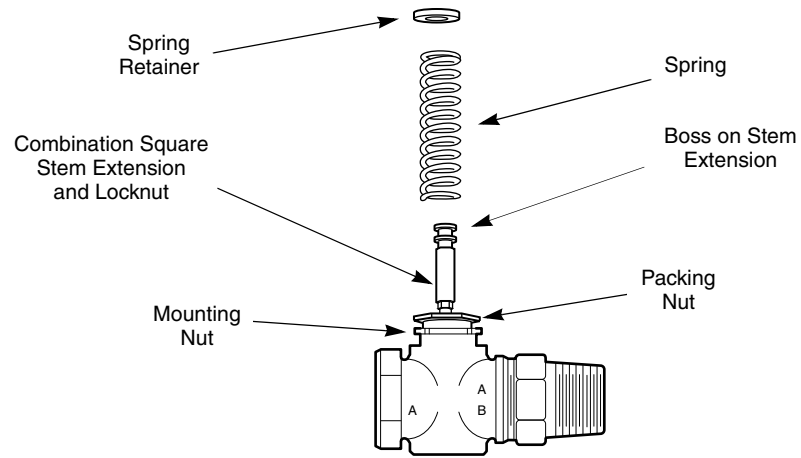

Figure-5 Assembly of AV-400 Linkage Kit onto VB-9xxx Series Valve.

2. Position the valve stem, stem up or stem down, as noted in Table-2.
3. Adjust the height of the stem extension to the "X" dimension shown in Table-2, Table-2, or Table-3 for the appropriate valve body. The "X" dimension is from the top of the stem extension to the top of the valve packing nut (Figure-6).

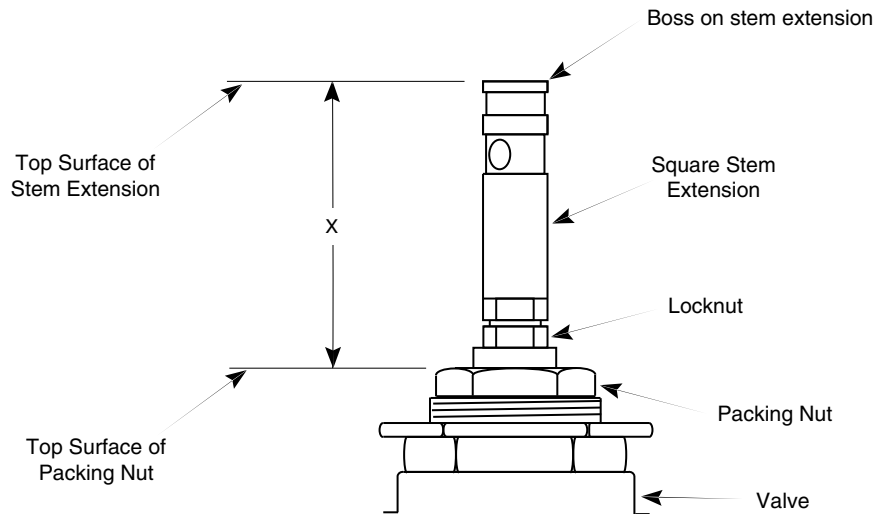

Figure-6 Stem Extension Height Adjustment.

4. Using one 3/8" wrench on the square stem extension and one on the locknut, hold the wrench stationary at the stem extension while turning the wrench at the locknut clockwise. The locknut should separate from the stem extension. Next, while still holding the wrench stationary at the stem extension, turn the wrench at the locknut counterclockwise to jam the locknut against the stem extension, securing it in position.
5. Select the correct spring from the linkage kit (Table-2).
6. Position the spring over the stem extension.
7. Insert Tool-19 or a 1/8" (3 mm) diameter rod through the spring coil and the hole in the stem extension (Figure-7).

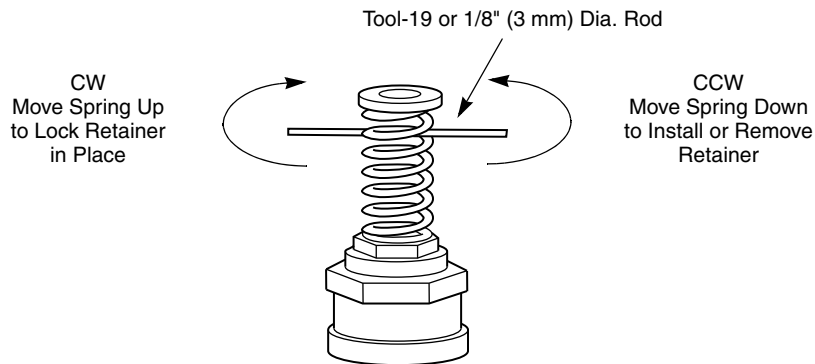

Figure-7 Installation of Linkage Spring.

8. Hold the spring to prevent it from turning. "Walk" the tool up the spring coil by turning it counterclockwise until the boss on the stem extension (Figure-5) projects above the top coil of the spring. Pushing down on the tool reduces torque required to turn the stem and plug into the seat.
9. Install the spring retainer (Figure-5) onto the stem extension and turn the retainer 45° to lock it in place.
10. Turn the tool clockwise, down the spring coil, to release the spring tension. Remove the tool from the assembly.
11. Install the actuator onto the valve by screwing the actuator base onto the mounting nut (Figure-8). The actuator may be rotated as desired to facilitate making the pneumatic connection.

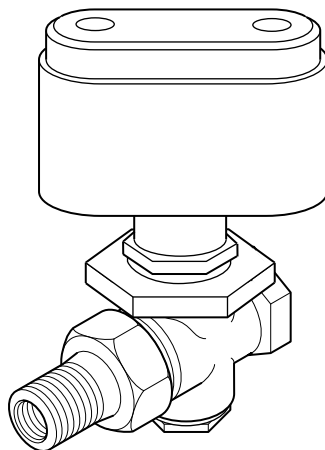

Figure-8 MK-2690 Actuator Mounted on Valve.

MAINTENANCE

The actuator linkage requires no maintenance.

Regular maintenance of the total system is recommended to assure sustained, optimum performance. Hard water leaves abrasive deposits and reduces component life. To maximize valve life consult **EN-205, Water System Guidelines, F-26080**.

FIELD REPAIR

Individual parts of the actuator linkage are not repairable. Replace an inoperative actuator linkage with a functional unit, or replace individual parts as necessary (Table-4 and Figure-9).

Table-4 AV-400 Replacement Parts.

Item (See Figure-5)	Part No.	Description
1	YBA-648	Stem Extension (square)
2	PNV-144-043	3-7 psi Spring (Yellow)
	PNV-145-045	5-10 psi Spring (Black)
	PNV-145-048	8-13 psi Spring (Blue)
3	YBA-559	Spring Retainer
4	NYBA-80	Stem Coupler (hexagon)
	NYBA-78	Spring Compression Screw
5	NYBA-82	Linkage Wrench

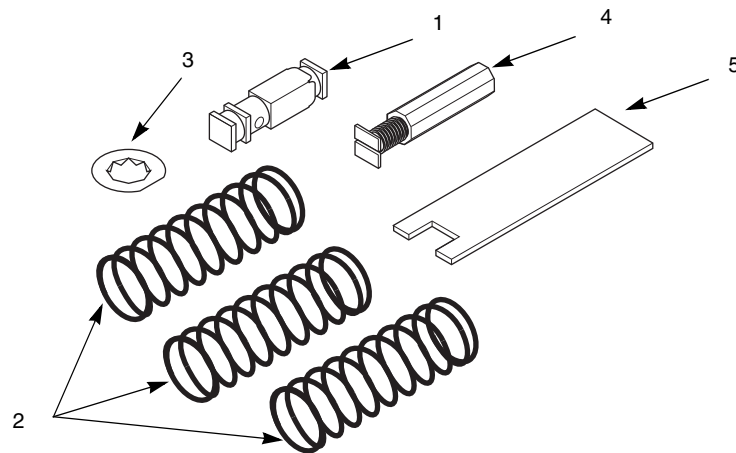

Figure-9 AV-400 Pneumatic Actuator Valve Linkage Kit.

On October 1st, 2009, TAC became the Buildings business of its parent company Schneider Electric. This document reflects the visual identity of Schneider Electric, however there remains references to TAC as a corporate brand in the body copy. As each document is updated, the body copy will be changed to reflect appropriate corporate brand changes.

Copyright 2010, Schneider Electric
All brand names, trademarks and registered
trademarks are the property of their respective
owners. Information contained within this
document is subject to change without notice.

