

AM-726/7, AM-7281

Actuator Accessory Mounting Kits for 35 and 70 lb.-in. for NSR Direct Coupled SmartX Actuators

Application

The AM-726 and AM-727 accessory kits provide a means for changing the actuator rotary motion to linear motion for the 35 lb.-in. MF41-6043 and MS41-6043 series and the 70 lb.-in. MF41-6083 and MS41-6083 series non-spring return direct coupled damper actuators.

The AM-728 accessory kit provides a conduit connection for the 35 lb.-in. MF41-6043 and MS41-6043 series and the 70 lb.-in. MF41-6083 and MS41-6083 series non-spring return direct coupled damper actuators.

Applicable Documentation

| Doc No. | Description | Audience | Purpose |
|---------|--|--|--|
| F-23638 | Cross-Reference Guide | Applicable Engineers Installers Sales Personnel Service Personnel | Provides specifications and part number cross-referencing of phased out controls with the new Schneider Electric controls. |
| F-26789 | Component Cross-Reference Guide | | Provides specifications and part number cross-referencing of phased out controls with the new Schneider Electric controls. |
| F-21683 | Reference Manual | | Provides a collection of general and installation instructions and other reference documents. |
| F-27383 | Pneumatic Products Catalog | | Provides descriptions and specifications for the Schneider Electric components. |
| F-27213 | MF41-6043 and MF41-6083 Series Schneider Electric Non-Spring Return Floating Direct Coupled SmartX Actuator General Instructions | | Describes the actuator's features, specifications, and possible applications. Provides step-by-step mounting instructions. |
| F-27214 | MS41-6043 and MS41-6083 Series Schneider Electric Non-Spring Return Proportional Direct Coupled SmartX Actuator General Instructions | | |

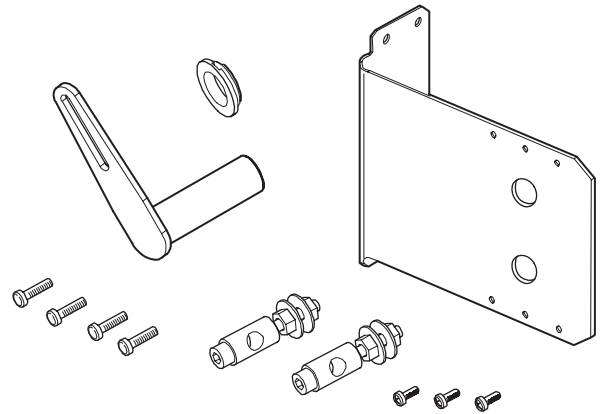

AM-726

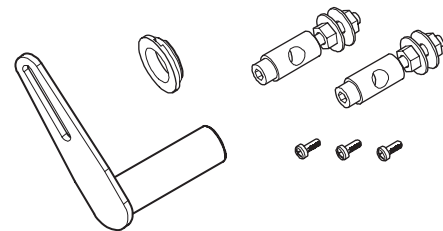

AM-727

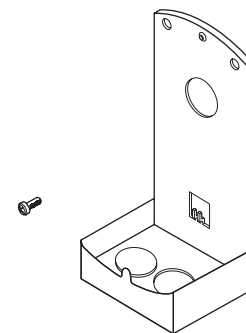

AM-728

Life Is On

Schneider Electric

Installation

Inspection

Inspect package for damage. If damaged, notify carrier immediately. Inspect hardware for damage. Return damaged products.

Requirements

- Training: Installer must be a qualified, experienced technician.
- Tools (not provided):
 - 1/8" (3 mm) hex wrench
 - 25/64" (10 mm) wrench
 - 3/8" (5 mm) hex wrench
 - #2 Phillips screwdriver
 - 5/32" (4 mm) drill bit
 - Other hand tools as appropriate

Precautions

Notice: Electrical shock hazard! Mechanical pinch point hazard! Disconnect power and allow equipment to come to a complete stop before attempting installation.

Enclosure Rating

These accessories can be used in any environment that the Mx41-60x3 Schneider Electric Non-Spring Return SmartX actuators are used.

Mounting

AM-727

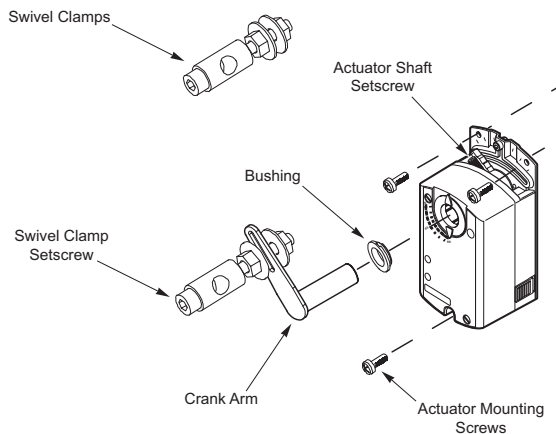

Figure 1 Installation of AM-727 Accessory Kit.

The Mx41-60x3 Schneider Electric non-spring return SmartX actuator should already be mounted in place.

1. Remove the black bushing from the front of the actuator and insert the kit bushing.
2. Manually rotate the actuator to the closed position.
3. Back the actuator shaft set screw out, using a 1/8" (3 mm) hex wrench.
4. Insert the crankarm and position it in the closed position.
5. Tighten the actuator shaft set screw against the shaft.
6. Attach the first swivel clamp to the crank arm midway between the slot and the device that will be controlled. Tighten the nuts using a 25/64" (10 mm) wrench.
7. Back out the swivel clamp set screw using a 3/8" (5 mm) hex wrench.
8. Place the second swivel clamp set screw at the controlled device. Tighten the nuts using a 25/64" (10 mm) wrench.
9. Place the controlled device in the closed position and insert the connecting rod (not supplied) into both swivel clamps.
10. Tighten the swivel clamp set screws with both ends in the closed position.

Note: To preload the actuator: Loosen the clamp screw on one swivel clamp and rotate the actuator 30 in the open direction while holding the controlled device closed. Tighten the clamp screw. This helps to ensure the device is closed.

11. Test the opening/closing action and adjust the position of the swivel clamp at the actuator to provide more or less travel of the controlled device. Be certain to release the clamp screw on the connecting rod when making changes or the open and closed position of the controlled device will be changed.

AM-726

The rotary to linear bracket is pre-drilled and threaded for ease of mounting. The Mx41-60x3 Schneider Electric non-spring return SmartX actuator mounts directly to the bracket using screws provided. The crank arm and swivel clamps provide the linear connection.

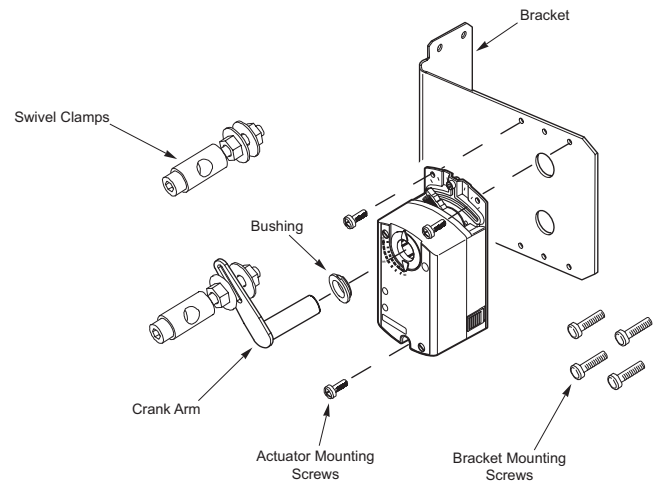

Figure 2 Installation of AM-726 Accessory Kit.

1. Locate the bracket in position and mark the four bracket mounting holes for drilling. Allow for the thickness of the actuator and crankarm.
2. Drill the four holes using a 5/32" (4 mm) drill.
3. Secure the bracket using the four bracket mounting screws.
4. Secure the actuator to the bracket using the three actuator mounting screws.
5. Refer to the Mounting section for the Rotary to Linear Crank Arm, AM-727.

AM-728

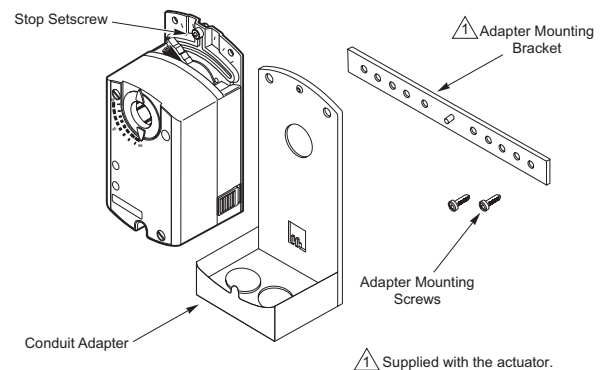

Figure 3 Installation of AM-728.

1. Loosen and remove the stop set screw and nut from the actuator, referring to Figure-4.

Installation Instructions

Note: To use the mechanical range stop, loosen the stop set screw and move it to either side of the track before attaching the actuator to the conduit adapter.

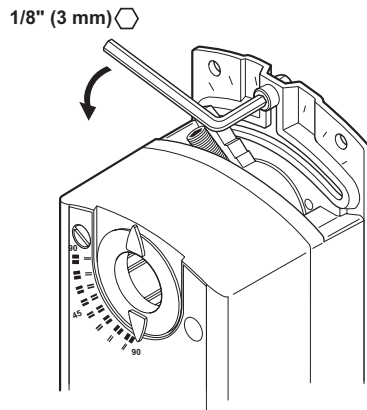

Figure 4 Loosening the Stop Set Screw.

2. Attach the desired conduit connector (not supplied) to the base of the conduit adapter. A second opening in the base of the adapter is available by removing the knock-out.
3. Thread the cable through the opening(s) in the conduit adapter.
4. Set the actuator in the adapter so the actuator fits into the guide on the adapter.

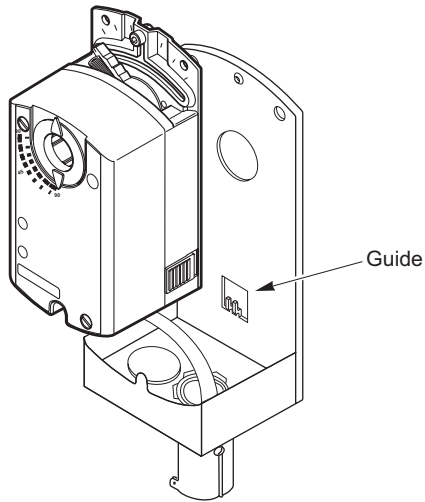

Figure 5 Setting the Actuator into the Adapter.

5. Fasten the actuator to the adapter with the screw provided, refer to Figure 6.

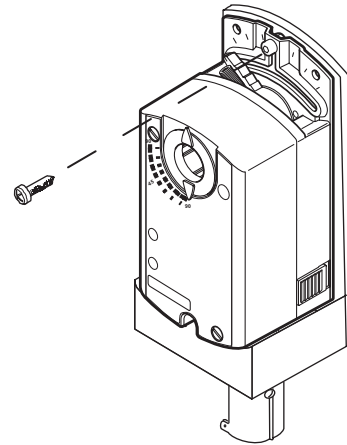

Figure 6 Fastening the Actuator to the Adapter.

6. Mount the actuator and adapter following the installation instructions that come with the actuator. The actuator mounting bracket (supplied with the actuator) fits between the guides in the lower back of the conduit adapter (Figure-7).

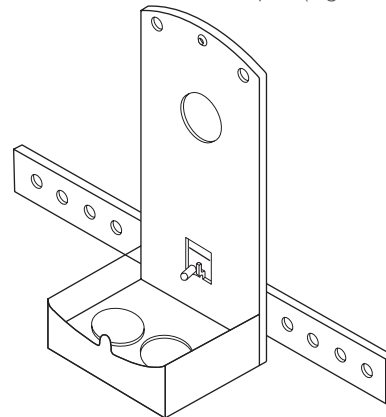

Figure 7. Adapter with Actuator Mounting Bracket.

