

## 6.0 RETURNING PRODUCTS FOR REPAIR

Please contact a Setra Systems application engineer (1-800-257-3872, 1-978-263-1400) before returning unit for repair to review information relative to your application. Many times only minor field adjustments may be necessary. When returning a product to Setra Systems, the material should be carefully packaged and shipped prepaid to:

Setra Systems, Inc.  
159 Swanson Road  
Boxborough, MA 01719-1304  
Attn: Repair Department

To assure prompt handling, please supply the following information and include it inside the package or returned material:

1. Name and phone number of person to contact.
2. Shipping and billing instructions.
3. Full description of the malfunction.
4. Identify any hazardous material used with product.

Notes: Please remove any pressure fittings and plumbing that you have installed and enclose any required mating electrical connectors and wiring diagrams.

Allow approximately 3 weeks after receipt at Setra Systems for the repair and return of the unit. Non-warranty repairs will not be made without customer approval and a purchase order to cover repair charges.

### Calibration Services

Setra maintains a complete calibration facility that is traceable to the National Institute of Standards & Technology (NIST). If you would like to recalibrate or recertify your Setra pressure transducers or transmitters, please call our Repair Department at 800-257-3872 (978-263-1400) for scheduling.

## 7.0 WARRANTY AND LIMITATION OF LIABILITY

SETRA warrants its products to be free from defects in materials and workmanship, subject to the following terms and conditions: Without charge, SETRA will repair or replace products found to be defective in materials or workmanship within the warranty period; provided that:

- a) the product has not been subjected to abuse, neglect, accident, incorrect wiring not our own, improper installation or servicing, or use in violation of instructions furnished by SETRA;
- b) the product has not been repaired or altered by anyone except SETRA or its authorized service agencies;
- c) the serial number or date code has not been removed, defaced, or otherwise changed; and
- d) examination discloses, in the judgment of SETRA, the defect in materials or workmanship developed under normal installation, use and service;
- e) SETRA is notified in advance of and the product is returned to SETRA transportation prepaid.

Unless otherwise specified in a manual or warranty card, or agreed to in writing and signed by a SETRA officer, SETRA pressure and acceleration products shall be warranted for one year from date of sale.

The foregoing warranty is in lieu of all warranties, express, implied or statutory, including but not limited to, any implied warranty of merchantability for a particular purpose.

SETRA's liability for breach of warranty is limited to repair or replacement, or if the goods cannot be repaired or replaced, to a refund of the purchase price. SETRA's liability for all other breaches is limited to a refund of the purchase price. In no instance shall SETRA be liable for incidental or consequential damages arising from a breach of warranty, or from the use or installation of its products.

No representative or person is authorized to give any warranty other than as set out above or to assume for SETRA any other liability in connection with the sale of its products.

# Installation Guide

## Model 256 Gage Pressure Transducer



SS2033 Rev.F 02/04/02



## Setra offers a complete line of products for these industries:

Industrial

HVAC

Test & Measurement

Barometric

Ultra High Purity/Sanitary

### 4.3 Current Output Zero Adjustment

While monitoring the current output, and with the pressure port open to atmosphere or with zero pressure applied, the zero may be adjusted by turning the zero potentiometer screw. The factory setting is 4mA ( $\pm 0.08$ mA).

### 4.4 Current Output Span Adjustment

Span or full scale output adjustments should only be performed by using an accurate pressure standard (electronic manometer, digital pressure gage, etc.) with at least comparable accuracy to the 256 transducer. With full range pressure applied to the pressure port, the span may be adjusted by turning the span potentiometer screw. The factory setting is 20mA ( $\pm 0.16$ mA).

## 5.0 MODEL 256 PERFORMANCE SPECIFICATIONS

	For Ranges 25 PSI and Higher	For Ranges Less Than 25 PSI
Accuracy RSS* (at constant temperature.)	$\pm 0.13\%$ FS	$\pm 0.25\%$ FS
Non-Linearity, BFSL	$\pm 0.1\%$ FS	$\pm 0.22\%$ FS
Hysteresis	0.08% FS	0.10% FS
Non-Repeatability	0.02% FS	0.05% FS

\*RSS of Non-Linearity, Non-Repeatability and Hysteresis.

#### Thermal Effects

Compensated Range °F(°C)	-4 to +176 (-20 to +80)	-4 to +176 (-20 to +80)
Zero Shift %FS/100°F (50°C)	$\pm 1.0$ ( $\pm 0.9$ )	$\pm 2.0$ ( $\pm 1.8$ )
Span Shift %FS/100°F (50°C)	$\pm 1.5$ ( $\pm 1.4$ )	$\pm 1.5$ ( $\pm 1.3$ )
Warm-up Shift	$\pm 0.1\%$ FS total	$\pm 0.1\%$ FS total

### 3.2 Current Output Units

The 4-20 mA current output units are designed to have current flow in one direction only - **PLEASE OBSERVE POLARITY**.

We suggest that the electrical conduit shield be connected to the system's loop circuit ground to improve electrical noise rejection.

The Model 256 is a two-wire loop-powered 4 to 20mA current output unit and delivers rated current into any external load of 0-800 ohms. (See Diagram 2 for location of +EXC and -EXC current output screw terminals.) The current flows into the + terminal and returns back to the power supply through the - terminal. (The center GND terminal may be used for shielding.) The power supply must be a DC voltage source with a voltage range between 9 and 30 measured between the + and - terminals. The unit is calibrated at the factory with a 24 VDC loop supply voltage and a 250 ohm load.

Minimum Supply Voltage (VDC) =  $9 + 0.02 \times (\text{resistance of receiver plus line})$ .  
Maximum Supply Voltage (VDC) =  $30 + 0.004 \times (\text{resistance of receiver plus line})$ .

### 4.0 CALIBRATION

The 256 transducer is factory calibrated and should require no field adjustment. Whenever possible, any zero and/or span offsets should be corrected by software adjustment in the user's control system. However, both zero and span adjustments are accessible by removing the screw top cover and the adjustment access cover and turning the potentiometer screw inside. (See Diagram 1 for the location of the Zero and Span potentiometers.)

#### 4.1 Voltage Output Zero Adjustment

While monitoring the voltage between the positive output (+OUT) and negative output (- OUT), and with the pressure port open to atmosphere, or with zero pressure applied, the zero may be adjusted by turning the zero potentiometer screw. The factory setting is 0.1 VDC ( $\pm 25\text{mV}$ ).

Note: -OUT and -EXC are commoned on the circuit.

**4.2 Voltage Output Span Adjustment** (Complete the zero adjustment before setting span.)

Span or full scale output adjustments should only be performed by using an accurate pressure standard (electronic manometer, digital pressure gage, etc.), with at least comparable accuracy to the 256 transducer. With full range pressure applied to the pressure port, the span may be adjusted by turning the span potentiometer screw. The factory setting is 5.1 VDC ( $\pm 50\text{mV}$ ).

## Table of Contents

1.0 GENERAL INFORMATION .....	4
2.0 MECHANICAL INSTALLATION .....	4
2.1 Media Compatibility.....	4
2.2 Environment .....	4
2.3 Pressure Fittings .....	4
2.4 Moisture Precautions.....	4
2.5 Venting.....	4
2.6 Mounting Accessories.....	5
3.0 ELECTRICAL INSTALLATION.....	5
3.1 Voltage Output Units.....	5
3.2 Current Output Units.....	6
4.0 CALIBRATION.....	6
4.1 Voltage Output Zero Adjustment.....	6
4.2 Voltage Output Span Adjustment .....	7
4.3 Current Output Zero Adjustment .....	7
4.4 Current Output Span Adjustment .....	7
5.0 MODEL 256 PERFORMANCE SPECIFICATIONS.....	7
6.0 RETURNING PRODUCTS FOR REPAIR.....	8
7.0 WARRANTY AND LIMITATION OF LIABILITY .....	8

# Setra Model 256 Pressure Transducer

## 1.0 GENERAL INFORMATION

Every Model 256 has been tested and calibrated before shipment. Specific performance specifications are listed on Page 7 of this Guide.

Setra Systems 256 pressure transducers sense gage pressure and convert this pressure to a proportional high level analog output. Two output versions are offered: A voltage output of .1 to 5.1 VDC, and a current output of 4 to 20 mA.

## 2.0 MECHANICAL INSTALLATION

### 2.1 Media Compatibility

Model 256 transducers are designed to be used with any gas or liquid compatible with 17-4 PH Stainless Steel. (Hydrogen is not recommended for use with 17-4 PH SS.)

### 2.2 Environment

The operating temperature limits of the 256 are as follows:

Operating Temperature Range °F (C°) -40 to +260 (-40 to +125)  
Compensated Temperature Range°F (C°) -4 to +176 (-20 to +80)

### 2.3 Pressure Fittings

Typically, standard pipe fittings and installation procedures should be used. However, for very high pressure ranges in excess of 500 psig, we suggest the use of a sealant such as Loctite Hydraulic Sealant. Excessive high torquing of metal fittings may cause a slight shift of the output, but this shift can be trimmed out by the zero adjustment. Torquing does not significantly affect linearity or sensitivity.

### 2.4 Moisture Precautions

The Model 256 is provided with two 1/2" NPT female conduit ports for electrical termination. These tapered pipe threads are tapped deeper than the NPT standard, in accordance with industry guidelines. These ports must be sealed according to standard industry practice, in order to prevent moisture ingress into the Model 256.

### 2.5 Venting

The Model 256 is a true gage pressure transducer. This means that the reference side of the pressure sensing diaphragm must be vented to atmosphere. If the reference side of the diaphragm were sealed (as in a sealed gage transducer), temperature changes would cause the reference pressure to vary. This may affect the overall accuracy, especially in ranges lower than 500 psig. The Model 256 provides a vent from the reference side of the sensor to the inside of the housing and the conduit ports. The user-provided electrical conduit must be vented to atmosphere in a clean dry location. **(It is important to prevent moisture ingress from the environment into the wiring chamber or reference side of the transducer.)**

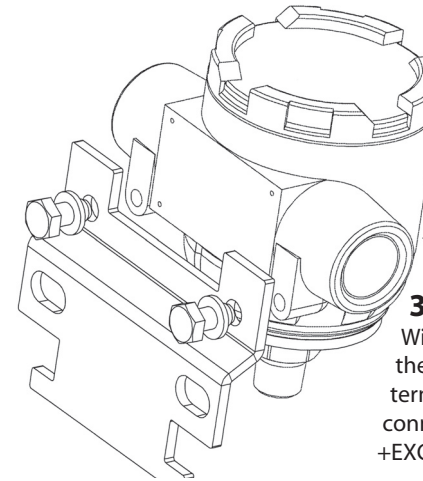

## 2.6 Mounting Accessories

The Model 256 is provided with a bracket and two hex bolts for mounting and a 1/2" NPT plug for the unused conduit opening. The bracket is suitable for mounting with a U-bolt or a band clamp. There are 1/4-20 UNC threaded holes on the back of the 256 transducer for direct mounting and/or grounding.

## 3.0 ELECTRICAL INSTALLATION

Wiring is through a 1/2" conduit opening. Remove the screw cover to access the removable wiring terminal block connector. The terminal block connector version has five terminals for wiring +EXC, -EXC, GND, -OUT, and +OUT (see Diagram 1).

Remove the terminal block connector to facilitate wiring to screw terminals. Refer to the terminal block connector label for terminal designations. (See Diagram 2 for screw terminal designations.) After wiring, plug connector back into pin socket and neatly tuck all wiring into wire recess cavity.

Diagram 1

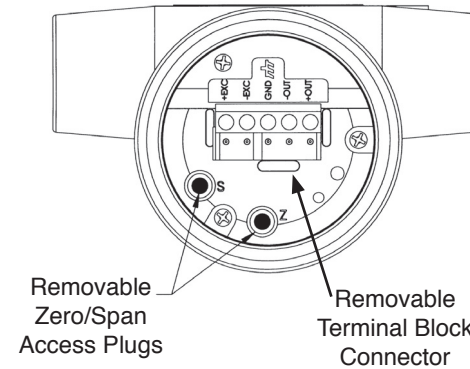
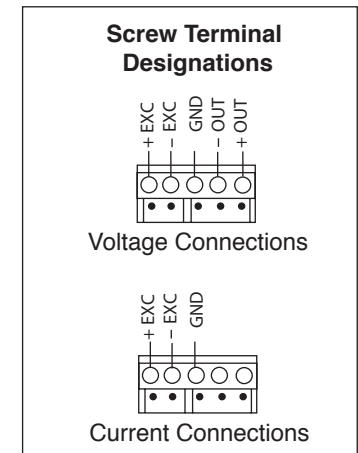

Diagram 2



### 3.1 Voltage Output Units

The Model 256 is a 3-wire circuit. The -EXC and -OUT are common on the circuit. The 256 can operate from a 12 to 28 VDC excitation. The 256 has a 0.1-5.1 VDC output.

- + Excitation; connect to 12-28 VDC power supply
- + Output; connect to controller or monitor
- Output; connect to controller or monitor
- Excitation; connect to return of 12-28 V power supply
- GND Connect to system or earth ground

The Model 256 can be wired as a three wire device by connecting - output, excitation and shield to a common ground. However, accuracy will be reduced with increase in lead resistance.