

FUSERBLOC BS88 Rear

Fuse combination switches with rear connection
from 63 to 400 A

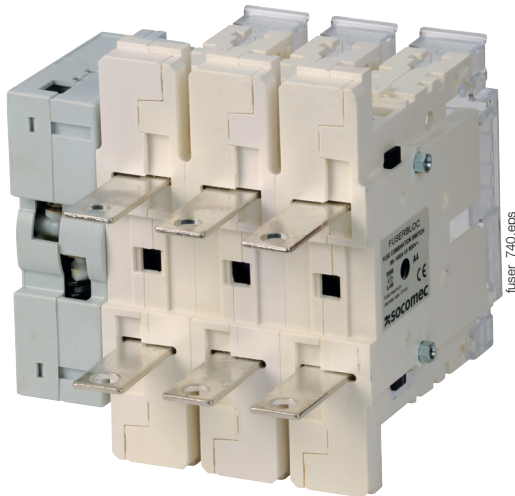

Function

FUSERBLOC BS88 Rear units are fuse combination switches with rear connection and right frontside manual control which are available in various connection combinations. They provide make and break on load, safety disconnection and overcurrent protection for any low voltage electrical circuit. This range includes versions for direct and external operation, 3 and 4 poles and up to 400 A.

Advantages

Connection flexibility

Fuse combination switches can combine the various types of connections:

- rear/rear (R/R),
- front/rear (F/R)

This flexibility simplifies separation between control, switching and connection spaces while reducing the required space of the overall solution.

Optimum safety

Double phase breaking (upstream and downstream of the fuse) and fully visible isolation keep people and equipment protected from overcurrent.

High breaking capacity

High breaking capacity fuses (100 kA rms) provide protection from overloads and short circuits.

Multi-use

The unit can be equipped with front or side operation handle, mounted directly on the product, or outside, with the possibility of installing it on the door or on the side of an electrical box or cabinet.

Simplified use

The TEST position enables testing of the control circuits without turning on the power thanks to the use of U-type auxiliary contacts.

In the TEST position, the cabinet door can be opened.

The solution for

- > Data centre
- > Healthcare
- > Industry
- > Building

Strong points

- > Connection flexibility
- > Optimum safety
- > High breaking capacity
- > Multi-use
- > Simplified use

Conformity to standards

- > IEC 60947-3
- > IEC 60269-1
- > IEC 60269-2



Available on request

- > Multipolar Fuserbloc with various coupling possibilities such as:
3 x 400 A + 3 x 50 A with front or side operation

Sustainable advantages

- > Replace only the fuse
- not the entire protection system -
to extend the installation's lifespan.
- > RoHS & REACH compliant

FUSERBLOC BS88 Rear

Fuse combination switches with rear connection
from 63 to 400 A

General characteristics

- For fuses up to 400 A.
- Up to 690 VAC.
- Up to 100 kA.
- Available in 3P or 4P versions.
- Connection types: R/R and F/R.

What you need to know

- In addition to the FUSERBLOC rating, product selection also depends on the fuse characteristics and functional specifications, which need to be in accordance with the application. SOCOMEC FUSERBLOC are available for utilisation with BS88 fuses.

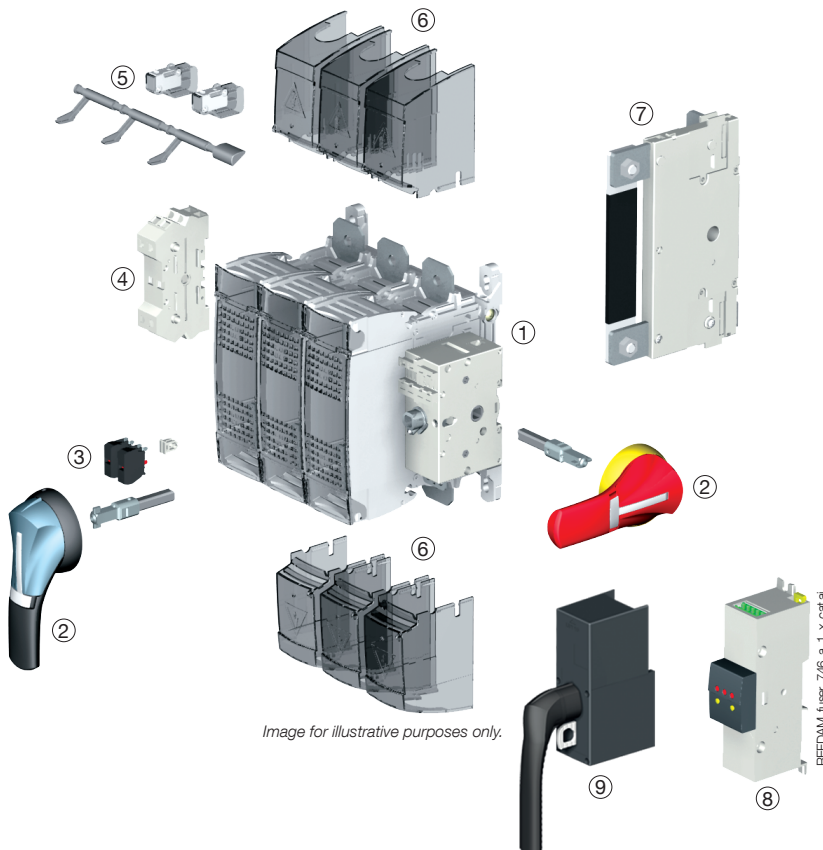

1. FUSERBLOC switch fuse
2. External front or side operation handle
3. U type auxiliary contact (pré-break and switch position signalling)
4. S and ST auxiliary equipment control and switch position signalling contacts
5. Melted fuse mechanical detection and indication device (DDMM)
6. Top and bottom terminal shrouds
7. Integrated solid neutral link
8. Electronic fuse monitoring device (FMD) detects worked fuse and provides signals to operator, PLC or supervision systems. Compatible with BS88, DIN and UL fuse types.
 - LED visual indication
 - Bi-stable relay for PLC: alarm, remote device tripping, etc.
 - TEST button: any time functional product verification
 - FUSERBLOC direct mounting, either back plate, DIN-rail or door mounting
9. Direct control handle.

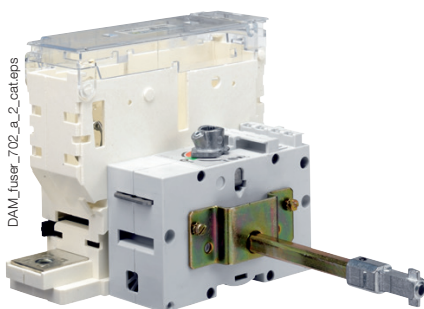

For ratings 32 to 400 A, the flat mounting kit provides a compact solution ideally suited to withdrawable applications.

FUSERBLOC BS88 Rear

Fuse combination switches with rear connection

from 63 to 400 A

References

BS 88 - External front and side operation - 63 to 400 A

Rating (A) Fuse size Frame size	No. of poles	Rear / Front Switch I - 0 - TEST	Rear / Rear Switch I - 0 - TEST	External front handle I - 0	TEST External front handle I - 0 - TEST	External right side handle I - 0	Shaft extensions for handle	Terminal shrouds ⁽³⁾	U type A/C ⁽²⁾	Integrated solid neutral link											
32 A A1 11	3 P	-	-	S1 type	S1 type	S1 type	320 mm 1400 1032	IP2x as standard	1 contact NO 3999 0701	3829 9310											
	4 P	-	-	Black IP65 1413 2111 ⁽¹⁾	Black IP65 1413 2115 ⁽¹⁾	Black IP65 1417 2111 ⁽¹⁾															
63 A A2-A3 12	3 P	-	3841 3106	Red/Yellow IP65 1414 2111	Red/Yellow IP65 1414 2115	Red/Yellow IP65 1418 2111					320 mm 1400 1032	-	1 contact NC 3999 0702	3829 9320							
	4 P	-	-	-	-	-															
100 A A4 ⁽⁴⁾ 13	3 P	-	3841 3110	S2 type	S2 type	S2 type									320 mm 1400 1032	-	1 contact NC 3999 0702	3829 9320			
	4 P	-	3841 6110																		
160 A B1-B2 14	3 P	-	3841 3116				Black IP65 1423 2111 ⁽¹⁾	Black IP65 1423 2115 ⁽¹⁾	Black IP65 1427 2111 ⁽¹⁾	320 mm 1400 1032									-	1 contact NC 3999 0702	3829 9320
	4 P	-	3841 6116																		
250 A B1-B2-B3 15	3 P	-	3841 3124				Red/Yellow IP65 1424 2111	Red/Yellow IP65 1424 2115	Red/Yellow IP65 1428 2111		320 mm 1400 1032	-	1 contact NC 3999 0702	-							
	4 P	-	3841 6124																		
400 A B1-B2- B3-B4 16	3 P	-	3841 3139	S2 type	S2 type	S2 type	320 mm 1400 1032	-	1 contact NC 3999 0702						Rear / Rear 3829 1339						
	4 P	3841 6239	3841 6139																		

(1) Standard.

(2) 4 auxiliary contacts as standard without additional contact holder.

(3) Top/bottom.

(4) For fuse size A4: max diameter 31 mm.

Accessories

Frame front handle can be locked in position 0 for direct control

Rating (A)	Frame size	Command	Handle colour	Reference
63 - 160	11-12-13-14	I-0-TEST	Black	3999 5020
250 - 400	15-16	I-0-TEST	Black	3999 5021



External front operation handle

Padlockable handle in position 0

Rating (A)	Frame size	Handle type	Handle colour	Operation	External IP ⁽¹⁾	Defeatable handle	Reference
63	11/12	S1	Black	I - 0	IP55	Yes	1411 2111
	11/12	S1	Black	I - 0	IP65	Yes	1413 2111
	11/12	S1	Red/Yellow	I - 0	IP65	Yes	1414 2111
	11/12	S1	Black	I - 0 - Test	IP65	Yes	1413 2115
	11/12	S1	Red/Yellow	I - 0 - Test	IP65	Yes	1414 2115
100 ... 400	13 ... 16	S2	Black	I - 0	IP55	Yes	1421 2111
	13 ... 16	S2	Black	I - 0	IP65	Yes	1423 2111
	13 ... 16	S2	Red/Yellow	I - 0	IP65	Yes	1424 2111
	13 ... 16	S2	Black	I - 0 - Test	IP65	Yes	1423 2115
	13 ... 16	S2	Red/Yellow	I - 0 - Test	IP65	Yes	1424 2115

(1) IP: protection degree according to IEC 60529 standard.



S1 type handle



S2 type handle

Padlockable handle in position 0 and I

Rating (A)	Frame size	Handle type	Handle colour	External IP ⁽¹⁾	Reference
63	11/12	S1	Black	IP65	1413 2311
100 ... 400	13 ... 16	S2	Black	IP65	1423 2311

(1) IP: protection degree according to IEC 60529 standard.

External right side operation handle

Rating (A)	Frame size	Handle type	Handle colour	External IP ⁽¹⁾	Reference
63	11/12	S1	Black	IP55	1415 2111
	11/12	S1	Black	IP65	1417 2111
	11/12	S1	Red/Yellow	IP65	1418 2111
100 ... 400	13 ... 16	S2	Black	IP55	1425 2111
	13 ... 16	S2	Black	IP65	1427 2111
	13 ... 16	S2	Red/Yellow	IP65	1428 2111

(1) IP: protection degree according to IEC 60529 standard.



S1 type handle

External front operation handle with metal padlocking lever

Rating (A)	Frame size	Handle type	Handle colour	External IP ⁽¹⁾	Defeatable handle	Reference
63	11/12	S1	Black	IP65	Yes	141D 2911
	11/12	S1	Red/Yellow	IP65	Yes	141E 2911
100 ... 400	13 ... 16	S2	Black	IP65	Yes	142D 2911
	13 ... 16	S2	Red/Yellow	IP65	Yes	142E 2911

(1) IP: protection degree according to IEC 60529 standard.



S1 type handle

FUSERBLOC BS88 Rear

Fuse combination switches with rear connection

from 63 to 400 A

Accessories (continued)

S-type handle adapter

Use
Enables S-type handles to be fitted in place of existing older style Socomec handles. Adapter can be utilised as a spacer to increase the distance between the panel door and the handle lever.

Dimensions
Adds 12 mm to the depth of the handle.

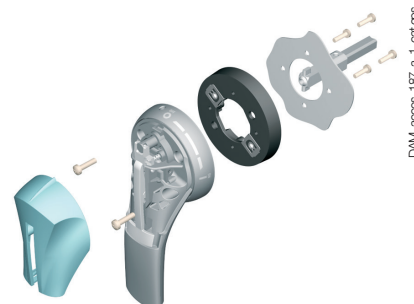

DAM_access_187_a_1_cat.eps

Handle colour	To be ordered in multiples of	External IP ⁽¹⁾	Reference
Black	1	IP65	1493 0000

(1) IP: protection degree according to IEC 60529 standard.

Alternative S-type handle cover colours

Use
For single lever handles S1 and S2 type.

Other colours:
please consult us.

Handle colour	To be ordered in multiples of	Handle type	Reference
Light grey	50	S1, S2	1401 0001
Dark grey	50	S1, S2	1401 0011



DAM_access_198_a_1_cat.eps

Flat mounting kit

Use
The flat mounting providing compact solution ideally suited to withdrawable applications. Kit to be used with a handle for flat mounting.

Rating (A)	Frame size	Type	Reference
32 ... 400	11 ... 16	Kit + Shaft 200 mm	1429 7710 ⁽¹⁾

(1) External operation handle to be ordered separately.

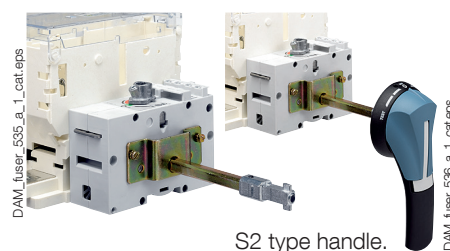

DAM_user_535_a_1_cat.eps

DAM_user_536_a_1_cat.eps

S2 type handle.

Front operation shaft support accessory

Use
This support maintains shaft position for extension shafts greater than 320 mm in length.

Rating (A)	Frame size	Reference
32 ... 400	11 ... 16	3899 0400



DAM_user_668_a_2_cat.eps

Accessories (continued)

Shaft guide for external operation

Use

To guide the shaft extension into the external handle.

This accessory enables the handle to engage the extension shaft with a misalignment of up to 15 mm. Required for a shaft lengths over 320 mm.

Description	Reference
Shaft guide	1429 0000



Shaft for external front operation handle

Use

Standard lengths:

- 200 mm
- 320 mm
- 500 mm.

Other lengths:
consult us.

Rating (A)	Frame size	Shaft length (mm)	Reference
63 ... 400	11 ... 16	200	1400 1020
63 ... 400	11 ... 16	320	1400 1032
63 ... 400	11 ... 16	500	1400 1050 ⁽²⁾

(1) Use the shaft guide accessory for external operation.

(2) Use the front operation shaft support accessory.

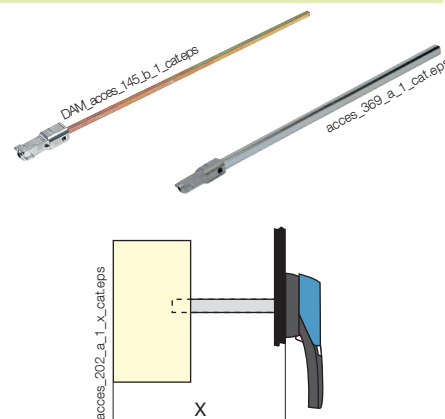

Dimension X (mm) for FUSERBLOC BS88

Rating (A)	32	63 ... 100	160	250 ... 400
Fuse size	A1	A2-A3/A4	B1-B2	B1-B2-B3
Frame size	11	12/13/14	14/15	15/16
Shaft length (mm)				
200	100 ... 230	125 ... 230	135 ... 230	160 ... 230
320	100 ... 350	125 ... 350	135 ... 350	160 ... 350
500	100 ... 530	125 ... 530	135 ... 530	160 ... 530

Dimension X (mm) for FUSERBLOC NFC and DIN

Rating (A)	50	100 ... 160	160	250 ... 400
Fuse size	14x51	22x58/00	0	1/2
Frame size	11	13	14	15/16
Shaft length (mm)				
200	100 ... 230	135 ... 230	145 ... 230	160 ... 230
320	100 ... 350	135 ... 350	145 ... 350	160 ... 350
500	100 ... 530	135 ... 530	145 ... 530	160 ... 530

FUSERBLOC BS88 Rear

Fuse combination switches with rear connection

from 63 to 400 A

Accessories (continued)

Shaft extensions for external side operation

Use

Standard lengths, 200 mm.

Rating (A)	Frame size	Handle type	Dimension Y (mm)	Shaft length (mm)	Reference
63 ... 400	11 ... 16	S	36 ... 172	200	1400 1020

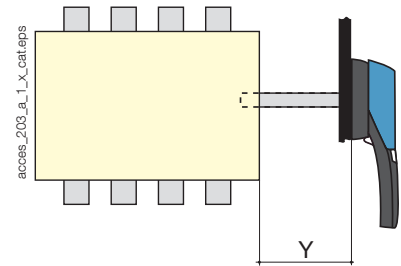

Integrated solid neutral link

Use

Fixing the solid neutral onto the mechanism produces a device with a solid neutral of the same size as a standard three-pole device (+ 6 mm).

Rating (A)	Switch body size	Bar rating (A)	Rear / Front Reference	Rear / Rear Reference
63 ... 125	11/12/13	125	3829 9310	3829 9310
160	13/14	200	3829 9320	3829 9320
250	15	250	3829 2325	3829 1325
400	16	400	3829 2312	3829 3312



Solid links

BS88 switches

Rating (A)	Frame size	Fuse size	I_{max} (A)	Reference
63	12	A2-A3	63	3629 9006
100	13	A4	160	3629 9010
160	14	B1-B2	200	3629 9016
250	15	B1-B2-B3	315	3629 9025
400	16	B1-B2-B3-B4	400	3629 9040

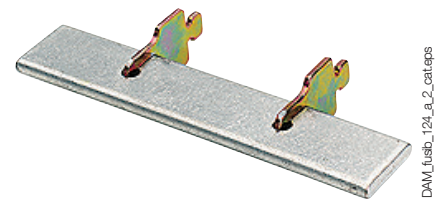
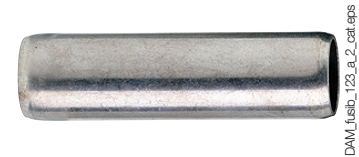

Accessories (continued)

U-type auxiliary contacts⁽¹⁾

Use

Compact universal type auxiliary contacts which can be configured for operation in either, or both, ON and TEST positions for CD 20 to 1250 A FUSERBLOC. Each slot can accommodate up to two interlocked A/Cs.

Connection to the control circuit

By terminals with max. section 2 x 2.5 mm².
For FUSERBLOC CD 20 to 400 A.
Pre-break and signalling of positions 0, I and TEST.
For FUSERBLOC ≥ 630 A: Pre-break and position 0 and I signalling.

References

NO auxiliary contacts

Rating (A)	Frame size	Contact(s)	Reference ⁽¹⁾
63 ... 400	11 ... 16	1	3999 0701 ⁽²⁾

NC auxiliary contacts

Rating (A)	Frame size	Contact(s)	Reference ⁽¹⁾
63 ... 400	11 ... 16	1	3999 0702 ⁽²⁾

(1) Cannot be mounted in direct operation CD20 - CD32 switches.

(2) 4 auxiliary contacts as standard without additional A/C holder.

Contact holder for additional auxiliary contacts

Rating (A)	Frame size	Contact(s)	Reference
63 ... 400	11 ... 16	4 (2 x 2 max)	3999 0600

Characteristics

Rating (A)	Operating current I _o (A)			
	250 VAC	400 VAC	24 VDC	48 VDC
	AC-15	AC-15	DC-13	DC-13
63 ... 400	3	1.8	2.8	1.4

S and ST-type auxiliary contacts

Use

For FUSERBLOCs 32 to 1250 A, position 0 and I signalling by 1 to 4 NO + NC auxiliary contacts.

Electrical principle

The NO + NC S-type auxiliary contacts can be configured as 2 NC or 2 NO.

Connection

By terminals with max. cross-section 10 mm².

Mechanical characteristics

30 000 operations.

References

S-type auxiliary contacts 0-I for external front and right-side operation (Standard operation)

Rating (A)	Frame size	Contact type	S-type AC Reference	Drive shaft (optional)
				Reference
63 ... 400	11 ... 16	NC+NO	3999 0041 ⁽¹⁾	3999 0003

ST-type auxiliary contacts I-0-TEST for external front and right-side operation (TEST operation)

Rating (A)	Frame size	Contact type	Description	ST-type AC Reference	Drive shaft Reference
63 ... 400	11 ... 16	NC+NO	TEST + ON	3999 0141 ⁽²⁾	3999 0103
63 ... 400	11 ... 16	2 O	TEST + ON	3999 0241 ⁽²⁾	3999 0103

(1) Drive shaft included with S-type Auxiliary Contact.

(2) Drive shaft to be ordered in addition to the ST-type Auxiliary Contact.

Characteristics

Rating (A)	Current nominal (A)	Operating current I _o (A)	
		250 VAC	400 VAC
		AC-13	AC-13
63 ... 400	20	10	8

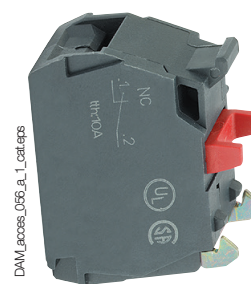

DAM_Laccess_056_a_1_contacts



DAM_Laccess_051_a_2_contacts

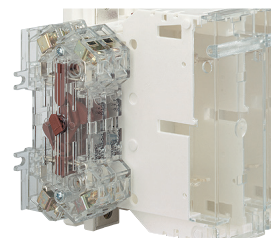

DAM_Laccess_053_a_1_contacts

FUSERBLOC BS88 Rear

Fuse combination switches with rear connection

from 63 to 400 A

Accessories (continued)

Terminal shrouds

Use

Top or bottom IP20 protection (on the front) against direct contact with terminals or connection parts.

Two sets required to fully shroud both incoming and outgoing terminals.

Rating (A)	Frame size	Position	No. of poles	Reference
63	11/12	top / bottom	3 / 4 P	integrated
100 ... 160	13/14	top / bottom	3 P	3998 3016
100 ... 160	13/14	top / bottom	4 P	3998 4016
200 ... 400	15/16	top / bottom	3 P	3998 3025
200 ... 400	15/16	top / bottom	4 P	3998 4025



REFDAM_fuser_314_a_1_cat.eps

Electronic fuse monitoring device (FMD)

Use

Provides fuse state monitoring and worked fuse indication even for fuse links without monitoring device strikers. Suitable for use with BS88, DIN and UL type fuses.

Principle

The Fuse Monitoring Device (FMD) detects the worked fuse and provides a signal via: a relay and a bi-stable relay and 3 LEDs (FMD30).

The FMD can be DIN rail or back plate mounted close to the Fuserbloc, directly mounted on the FUSERBLOC, or it can be door mounted to provide information directly on the front of a panel.

References

For FUSERBLOC 32 to 400 A

Nb of LEDs	Operating voltage Ph/Ph	Reference
3 (FMD30)	120 - 260 VAC	3899 3120
3 (FMD30)	380 - 690 VAC	3899 3380

Accessories		Reference
Kit for connection accessories	Standard	3819 9120
Kit for connection accessories	Door mounted	3829 9120



REFDAM_fmd_001_a.eps

3 LED version (FMD30)

Relay characteristics

Rating (A)	Relay operating current I _c (A)	
	AC-15	DC-13
63 ... 400	2.5 A	0.2

Accessories (continued)

Cage terminals

Use

Connection of bare copper cables onto the terminals (without lugs).

References

Rating max (A)	Frame size	No. of poles	Reference
63	11 ... 12	3 / 4 P	integrated
100 ... 160	13/14	3 P	5400 3016
100 ... 160	13/14	4 P	5400 4016
250	15	3 P	5400 3025
250	15	4 P	5400 4025
400	16	3 P	5400 3040
400	16	4 P	5400 4040

Connections

Rating (A)	Flexible cable cross-section (mm ²)	Rigid cable cross-section (mm ²)	Flexible bar width (mm)	Stripped over (mm)
100 ... 160	16 ... 95	16 ... 95	13	22
250	16 ... 185	16 ... 185	18	27
400	50 ... 240	50 ... 300	20	34

Dimensions

Rating (A)	A	A1	C	R	ØX	X1	Z
100 ... 160	47.5	22.5	25	20	8.5	M12	10
250	62	31.5	31.5	25	10.5	M16	14
400	71.5	32	38	32	10.5	M20	15



DAM_acces_053_a_1_cat.eps

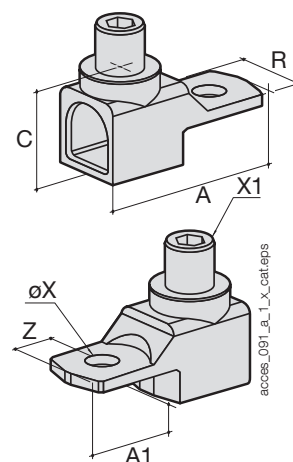

acces_092_a_1_x_cat.eps

acces_091_a_1_x_cat.eps

Handle key interlocking accessories

Use

Locking in position 0 of the direct, front or right side operation:

- using a padlock (not supplied) in direct right side operation: integrated into the handle,
- using a padlock (not supplied): right-side or front operation switch from 32 to 1250 A, factory integrated
- using a padlock (not supplied) in external operation.

Locking using RONIS EL 11 AP lock (not supplied)

Rating (A)	Frame size	Operation	Figure n°	Reference
63 ... 400	11 ... 16	external front	2	1499 7701

Locking using K-type CASTELL lock (not supplied)

Rating (A)	Frame size	Operation	Figure n°	Reference
63 ... 400	11 ... 16	external front	3	1499 7702

Locking using FS-type CASTELL lock (not supplied)

Rating (A)	Frame size	Operation	Figure n°	Reference
63 ... 400	11 ... 16	external front	3	1499 7703

Locking using XOP (not supplied)

Rating (A)	Frame size	Operation	Reference
63 ... 400	11 ... 16	external front	1499 7702

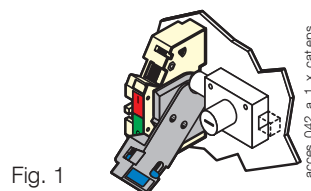

Fig. 1

acces_042_a_1_x_cat.eps

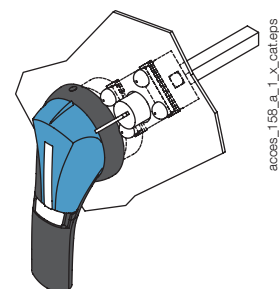

Fig. 2

acces_156_a_1_x_cat.eps

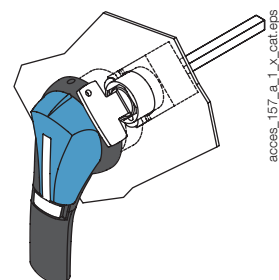

Fig. 3

acces_157_a_1_x_cat.eps

FUSERBLOC BS88 Rear

Fuse combination switches with rear connection

from 63 to 400 A

Characteristics according to IEC 60947-3

32 to 400 A

Reference	3841 X006	3841 X010	3841 X016	3841 X024	3841 X039
Type	Mod. 63 A	Mod. 100 A	Mod. 160 A	Mod. 250 A	Mod. 400 A
Frame size	12	13	14	15	16
Power pole pitch (mm)	32	36	50	60	66
Number of pole (SWN= switched neutral, SLN=solid neutral)	3, 4	3, 4	3, 4	3, 4	3, 4
Thermal current I_{th} (35°C)	63A	100A	160A	250A	400A
Fuse size BS88 & NFC/DIN	A2-A3	A4*	B1-B2	B1-B2-B3	B1-B2-B3-B4
Rated operational voltage U _e (V)	690V	690V	690V	690V	690V
Rated insulation voltage U _i (V)	800	800	800	800	1000
Rated impulse withstand voltage U _{imp} (kV)	8	8	8	8	12
Rated conditional short-circuit current (kA) in withstand and closing with gM/gG fuse					
Associated gM/gG fuse rating (A)	63	100	160	250	400
Prospective short-circuit current at U _e 400/415 VAC (kA rms)	100	100	100	100	50
Prospective short-circuit current at U _e 660/690 VAC (kA rms)	100	100	50	50	50
Dynamic withstand in I _{sc} U _e 415 VAC (peak kA)	7,3	11,9	22,66	23,9	33,5
Dynamic withstand in I _{sc} U _e 690 VAC (peak kA)	7,3	15,8	14	29	29,9
Rated operational currents I_c (A)					
Nominal voltage	Category of use	A/B⁽¹⁾	A/B⁽¹⁾	A/B⁽¹⁾	A/B⁽¹⁾
415 VAC	AC 21 A / AC 21 B	63/63	100/100	160/160	250/250
415 VAC	AC 22 A / AC 22 B	63/63	100/100	160/160	250/250
415 VAC	AC 23 A / AC 23 B	63/63	100/100	160/160	250/250
500 VAC	AC 21 A / AC 21 B	63/63	100/100	160/160	250/250
500 VAC	AC 22 A / AC 22 B	63/63	100/100	160/160	250/250
500 VAC	AC 23 A / AC 23 B	63/63	100/100	160/160	250/250
690 VAC ⁽³⁾	AC 20 A / AC 20 B	63/63	100/100	160/160	250/250
690 VAC ⁽³⁾	AC 21 A / AC 21 B	63/63	100/100	160/160	250/250
690 VAC ⁽³⁾	AC 22 A / AC 22 B	63/63	100/100	160/160	250/250
690 VAC ⁽³⁾	AC 23 A / AC 23 B	63/63	100/100	160/160	160/160
220 VDC	DC 21 A / DC 21 B	-/63	100/100	-	250/250
220 VDC	DC 22 A / DC 22 B	-	100/100	-	250/250
220 VDC	DC 23 A / DC 23 B	-	100/100	-	200/200
400 VDC	DC 21 A / DC 21 B	-/63 ⁽³⁾	100 ⁽³⁾ /100 ⁽³⁾	-	250 ⁽³⁾ /250 ⁽³⁾
400 VDC	DC 21 A / DC 21 B	-	-	-	-
400 VDC	DC 22 A / DC 22 B	-	100 ⁽³⁾ /100 ⁽³⁾	-	250 ⁽³⁾ /250 ⁽³⁾
400 VDC	DC 23 A / DC 23 B	-	100 ⁽³⁾ /100 ⁽³⁾	-	200 ⁽³⁾ /200 ⁽³⁾
440 VDC	DC 21 A / DC 21 B	-/63 ⁽³⁾	100 ⁽³⁾ /100 ⁽³⁾	-	250 ⁽³⁾ /250 ⁽³⁾
440 VDC	DC 22 A / DC 22 B	-	100 ⁽³⁾ /100 ⁽³⁾	-	250 ⁽³⁾ /250 ⁽³⁾
440 VDC	DC 23 A / DC 23 B	-	100 ⁽³⁾ /100 ⁽³⁾	-	200 ⁽³⁾ /200 ⁽³⁾
500 VDC	DC 21 A / DC 21 B	-/63 ⁽³⁾	100 ⁽³⁾ /100 ⁽³⁾	-	250 ⁽³⁾ /250 ⁽³⁾
500 VDC	DC 22 A / DC 22 B	-	100 ⁽³⁾ /100 ⁽³⁾	-	250 ⁽³⁾ /250 ⁽³⁾
500 VDC	DC 23 A / DC 23 B	-	100 ⁽³⁾ /100 ⁽³⁾	-	200 ⁽³⁾ /200 ⁽³⁾
Rated operational power in AC-23 (kW)					
At U _e 415 VAC w/o pre-break auxiliary contact ⁽¹⁾⁽⁵⁾		30/30	51/51	80/80	132/132
At U _e 690 VAC w/o pre-break auxiliary contact ⁽¹⁾⁽⁵⁾		55/55	90/90	110/110	220/220
Reactive power (kvar)					
At U _e 415 VAC ⁽⁵⁾		28	45	75	115
Power dissipation (W/pole)		8,4	14,5	23	41,1
Power dissipated by the fuse (W/pole)		6	9	15	23
Power dissipation by device (W/pole)		4,35	6,8	10,4	19
Connection capacity					
Minimum copper cable cross section (mm ²)		10	25	50	95
Maximum copper cable cross section (mm ²)		25	95	95	240
Maximum bar width (mm)		-	20	20	32
Minimum tightening torque (Nm)		3	9	9	20
Mechanical characteristics					
Durability (number of operating cycles)		10 000	10 000	10 000	10 000
Operating torque (Nm)		8.7	9.7	9.7	13
Weight of a non-accessorized 3-pole device (kg)		1	1.5	1.8	3.2
Weight of a non-accessorized 4-pole device (kg)		1.3	2	2.3	4.5
Weight in additional 1 P (kg)		0.3	0.5	0.5	1.3
Storage temperature (°C)				-50 ... +85	
Operating temperature (°C)				-20 ... +70	
Normative compliance				IEC 60947-3	
Certification				IEC, Loyd's et CCC	
Pollution degree		3	3	3	3

(1) Catégorie avec indice A = manœuvres fréquentes / Catégorie avec indice B = manœuvres non fréquentes.

(3) Appareil 3 pôles avec 2 pôles "+" en série et 1 pôle "-".

Dimensions

External operation

BS88 63 to 400 A

1. Position TEST.
2. Rear connection (option)
3. 1 or 2 CA type DDMM
4. 1 or 8 CA NO/NC pre-break.
5. Terminal shrouds.

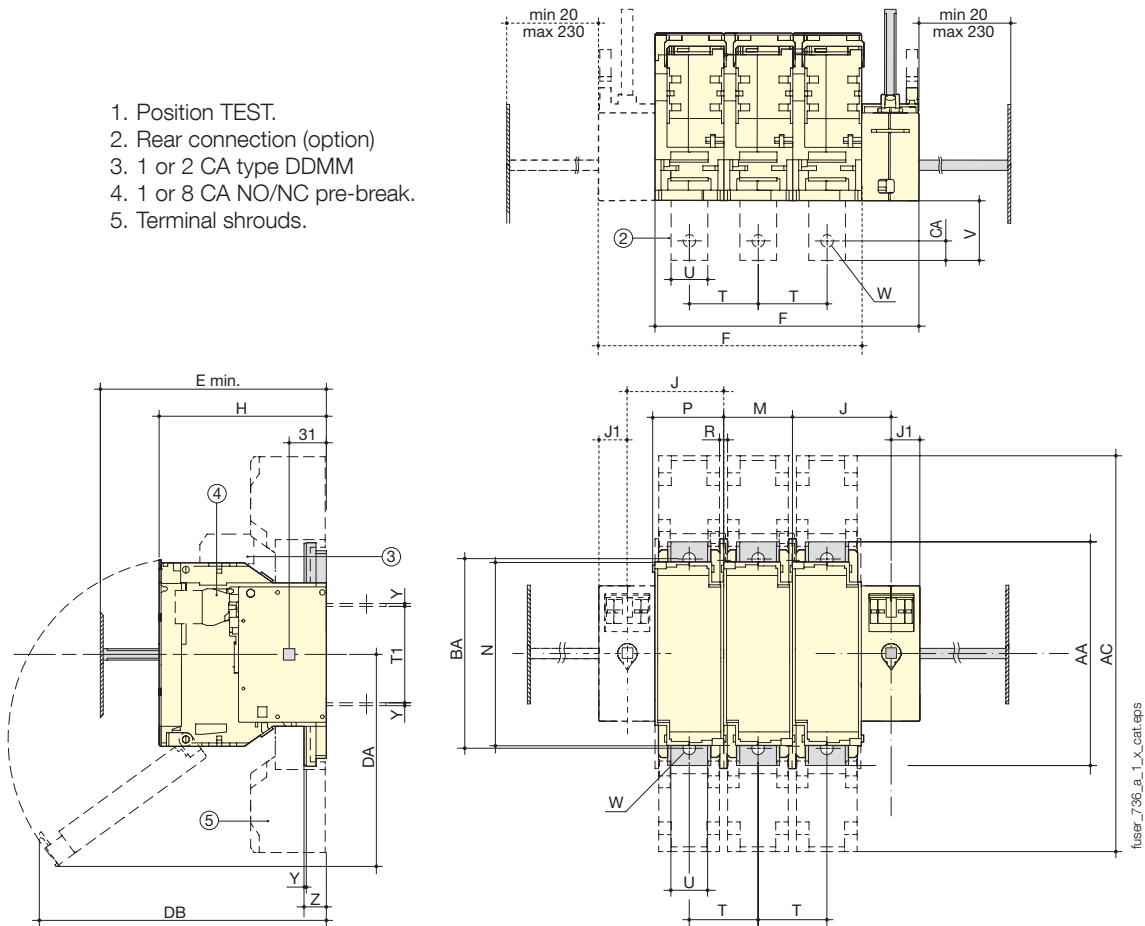

Rating (A)	BS88 Fuse size	Frame size	Overall dimensions	Terminal shrouds	Switch body						Switch mounting					Connection									
			E min	AC	F 3p.	F 4p.	H	J	J1	DA	DB	M	N	P	R	T	T1	U	W	Y	Z	AA	BA	CA	V
63	A2-A3	12	125	-	136	168	116	50	18	159	145	32	106	36	5.4	32	59	12	-	2	-	118	-	6	15
100	A4	13	135	268	148	184	116	54	18	141	179	36	127	40	5.4	36	62	20	8.5	2.5	19.5	162	141	8	41
160	-	13	135	268	148	184	126	54	18	141	189	36	127	40	5.4	36	62	20	8.5	2.5	19.5	162	141	8	41
250	B1-B2-B3	15	154	345	234	294	146	86	25	185	251	60	162	64	6.4	60	84	32	11	2.5	19.5	195	166	17	52
400	B1-B2-B3-B4	16	157	255	252	318	149	91	25	200	260	66	172	70	6.4	66	84	50	11	3	20	205	175	14.5	54

FUSERBLOC BS88 Rear

Fuse combination switches with rear connection

from 63 to 400 A

Dimensions for external operation handles

BS88 - 63 A

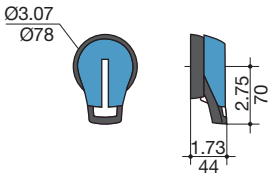
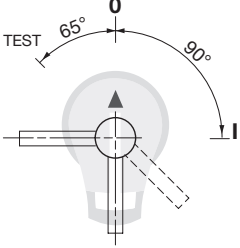
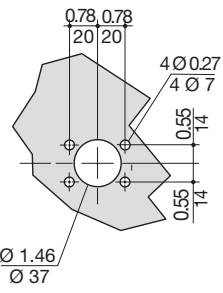
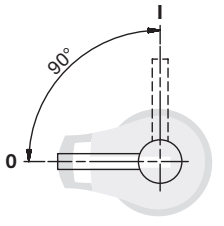
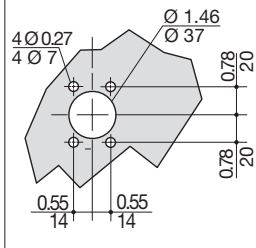
Handle type	Front operation		Right and left side operation	
	Direction of operation	Door drilling	Direction of operation	Door drilling
S1 type Box size 0 				

poign_051_b_1_gb_cat.eps

BS88 - 100 to 400 A

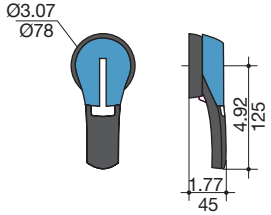
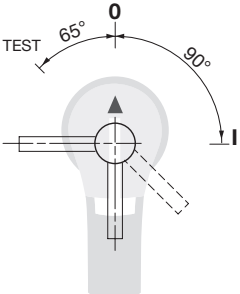
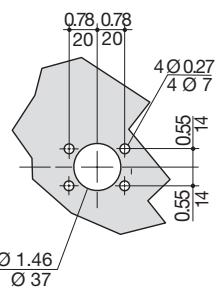
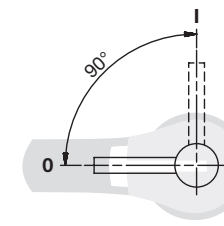
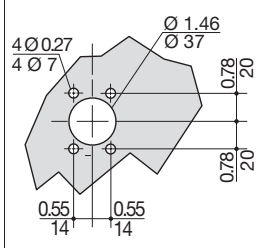
Handle type	Front operation		Right and left side operation	
	Direction of operation	Door drilling	Direction of operation	Door drilling
S2 type Box size 11-16 				

poign_052_b_1_gb_cat.eps

Dimensions for direct-control casings

50 to 400 A

Handle type

50 to 160 A
 Case 11 to 14

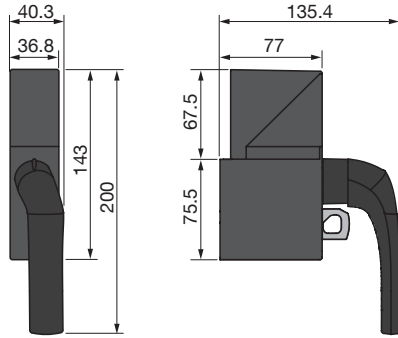

Direct operation
Operating direction

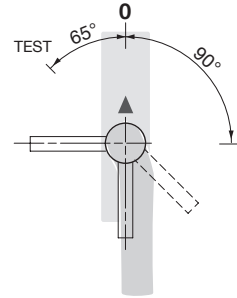

250 to 400 A
 Case 15 to 16

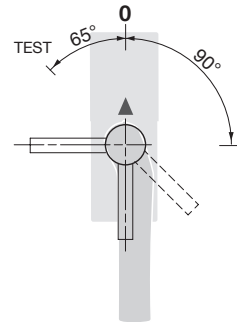
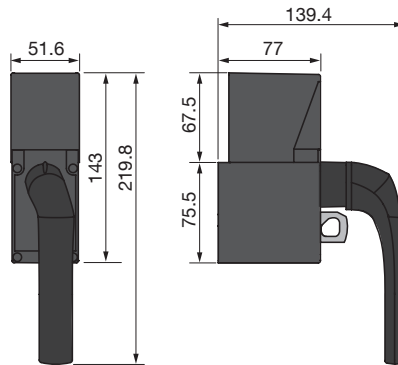

fuser_753_a_1_en_cat.ai