

S-Flex™ 212

Adjustable Speed Enclosed Drive

Instruction Bulletin

30072-451-83

Rev. 02 12/2012

Retain for future use.



by Schneider Electric

Table of Contents

	Hazard Categories and Special Symbols	5
	Please Note	5
	Product Support	5
SECTION 1: INTRODUCTION AND TECHNICAL CHARACTERISTICS		7
	Product Overview	7
	About This Document	7
	Terminology	7
	Before You Begin	8
	Catalog Number Description	11
	Nameplate Identification	12
	Technical Characteristics	13
	Short Circuit Ratings	14
	Input Current Ratings	14
	Technical Specifications	15
SECTION 2: RECEIVING, HANDLING, AND STORING		17
	Receiving and Preliminary Inspection	17
	Storing the Equipment	17
	Unpacking the Drive	18
	Before Installing the Drive	18
	Handling the Drive	18
SECTION 3: INSTALLATION AND START-UP		21
	Installation Guidelines	21
	Drive Weights	21
	Center of Gravity	22
	Dimensions for Wall or Panel Mounting	23
	Mounting Requirements	31
	Mounting on an EZM Mounting Channel	32
	Seismic Qualification Mounting Criteria	33
	Electrical Installation	34
	General Wiring Practices	34
	Input Power	34
	Branch Circuit Connections	35
	Input Wiring	35
	Grounding	36
	Connection to Ungrounded or High-Resistance Grounded Systems ..	36
	Wiring and Electromagnetic Compatibility	37
	Output Wiring	39
	DC Bus Voltage Measurement Procedure	40
	Wire Routing and Interconnection	42
	Wire Class	42
	Noise Class	42
	Voltage Class	42
	Wiring Methods	42
	Component Locations	44
	Power Wiring	46
	Control Wiring	48
	Keypad Operation	50
	Integrated Keypad	50
	Graphic Keypad Option (D07)	51

Initial Start-up Procedure	52
Checking the Enclosure Components and Connections	53
Adjusting ByPass Motor Overload Protection	54
Checking and Correcting Motor Rotation	55
Checking and Correcting Motor Rotation in Bypass Mode	55
Checking the Graphic Terminal Settings	56
Adjusting Mag-Gard or PowerPact Magnetic Trip Setting	57
Fusible Disconnect	58
Overload Relay Adjustment	58
SECTION 4: OPERATION	59
Programming the Power Converter	59
Power Circuit Y with Full Voltage Bypass	61
Power Circuit W Without Bypass	61
Operator Controls – General Arrangement and Operation	61
Damper Control	63
Smoke Purge Function (Fireman’s Override)	63
Options	64
SECTION 5: PROPORTIONAL–INTEGRAL–DERIVATIVE CONTROL	71
Introduction	72
Scaling of PID Parameters	73
PID Tuning	74
Setting PID Control	76
Drive Configuration via Integrated or Graphic Keypad	76
Control Loop Configuration	77
Control Loop Configuration	78
Sleep/Wake Operation	78
PID Control Waiting Time	79
Attain Speed Relay	79
Control Wiring	79
Application Notes	81
Programming the PID Internal Setpoint with the Keypad	81
SECTION 6: MAINTENANCE AND SUPPORT	83
Precautions	83
Diagnostic Codes	85
External Signs of Damage	86
Preventive Maintenance	86
Inspection	87
Maintenance after a Downstream Fault Has Occurred	87
Circuit Breaker Maintenance	87
Technical Support	87
Schneider Electric Services (On-Site)	88
Schneider Electric Customer Training	88
Product Literature	88
DRIVE CONFIGURATION	89
MOTOR NAMEPLATE DATA	89
POWER SOURCE AND ENVIRONMENT	89
DRIVE DETECTED FAULT CODES	89
DETAILED DESCRIPTION OF PROBLEM	89
Renewable Parts	90

Hazard Categories and Special Symbols

Read these instructions carefully and look at the equipment to become familiar with the device before trying to install, operate, service, or maintain it. The following special messages may appear throughout this bulletin or on the equipment to warn of hazards or to call attention to information that clarifies or simplifies a procedure.



The addition of either symbol to a “Danger” or “Warning” safety label indicates that an electrical hazard exists which will result in personal injury if the instructions are not followed.



This is the safety alert symbol. It is used to alert you to personal injury hazards. Obey all safety messages that follow this symbol to avoid possible injury or death.

⚠ DANGER

DANGER indicates a hazardous situation which, if not avoided, **will result in death or serious injury**.

⚠ WARNING

WARNING indicates a hazardous situation which, if not avoided, **can result in death or serious injury**.

⚠ CAUTION

CAUTION indicates a hazardous situation which, if not avoided, **can result in minor or moderate injury**.

NOTICE

NOTICE is used to address practices not related to physical injury. The safety alert symbol is not used with this signal word.

NOTE: Provides additional information to clarify or simplify a procedure.

Please Note

Electrical equipment should be installed, operated, serviced, and maintained only by qualified personnel. No responsibility is assumed by Schneider Electric for any consequences arising out of the use of this material.

Product Support

For support and assistance, contact the Product Support Group. The Product Support Group is staffed from 8:00 am until 8:00 pm Eastern time to assist with product selection, start-up, and diagnosis of product or application problems. Emergency phone support is available 24 hours a day, 365 days a year.

Toll Free	1-888-778-2733
E-mail	drive.products.support@schneider-electric.com
Fax	919-217-6508

Section 1—Introduction and Technical Characteristics

Product Overview

The S-Flex™ 212 enclosed drive is a full-featured adjustable speed package solutions for variable torque applications. The S-Flex enclosed drive is a bypass package that includes an Altivar™ 212 adjustable speed drive on a wall-mountable back plane with pre-packaged model number options for both power and control functions. The following features are available for the standard bypass package:

- AFC-Off-Bypass selector switch
- Local/Remote configurable on controller
- Power On red LED
- Bypass Run green LED
- Freeze/Firestat interlock
- Form C AFC detected fault contact
- Modbus™ RJ-45 communication port
- Smoke purge and damper control relays
- Circuit breaker disconnect
- Optional line disconnect switch or line contactor
- Optional full text keypad
- Optional non-bypass power circuit

About This Document

This instruction bulletin contains installation, programming, and maintenance instructions for the S-Flex enclosed drives. The following documentation is also provided with the drive:

- *Altivar 212 Installation Guide*, S1A53832
- *Altivar 212 Programming and Operation Guide*, S1A53838
- *Altivar 212 Quick Start Guide*, S1A53825
- *Handling, Installation, Operation, and Maintenance of Electrical Control Equipment*, Instruction Bulletin 30072-200-50

NOTE: To replace missing documents, contact your local Schneider Electric field office or download them from the Technical Library at www.Schneider-Electric.com.

Terminology

The following terminology is used throughout this instruction bulletin to distinguish between the S-Flex 212 enclosed drives and the Altivar 212H components.

- **Enclosed drive, or controller** refers to the combination of the power converter, enclosure, and the power and control circuits that constitute the S-Flex adjustable speed enclosed drive.
- **Drive**, as used in this manual refers to the controller portion of the adjustable speed drive as per the NEC.
- **Power converter** refers to the ATV212H series controllers (described in *Altivar 212 Installation Guide*, S1A53832) when used as a component in the S-Flex enclosed drive.

Before You Begin

⚠ DANGER

HAZARD OF ELECTRIC SHOCK, EXPLOSION, OR ARC FLASH

- Read and understand this manual before installing or operating the S-Flex drive. Installation, adjustment, repair, and maintenance must be performed by qualified personnel.
- The user is responsible for compliance with all international and national electrical code requirements with respect to grounding of all equipment.
- Many parts of this drive, including the printed circuit boards, operate at the line voltage. **DO NOT TOUCH.** Use only electrically insulated tools.
- Some terminals have voltage on them when the disconnect is open.
- **DO NOT** short across terminals PA/+ and PC/- or across the DC bus capacitors.
- Before servicing the drive:
 - Disconnect all power including external control power that may be present.
 - Place a “DO NOT TURN ON” label on all power disconnects.
 - Lock all power disconnects in the open position.
 - **WAIT 15 MINUTES** to allow the DC bus capacitors to discharge. Then follow the “DC Bus Voltage Measurement Procedure” on page 40 to verify that the DC voltage is less than 42 V. The drive LED is not an indicator of the absence of DC bus voltage.
- Install and close all covers and doors before applying power or starting and stopping the drive.

Failure to follow these instructions will result in death or serious injury.

⚠ DANGER

HAZARD OF ELECTRIC SHOCK, EXPLOSION, OR ARC FLASH

For 460 V units:

- Apply appropriate personal protective equipment (PPE) and follow safe electrical work practices. See NFPA 70E - Standard for Electrical Safety Requirements for Employee Workplaces and OSHA Standards - 29 CFR Part 1910 Subpart S Electrical, or CSA Z462.
- This equipment must only be installed and serviced by qualified electrical personnel.
- Never operate energized switch with door open.
- Turn off switch before removing or installing fuses or making load side connections.
- Always use a properly rated voltage sensing device at all line and load fuse clips to confirm switch is off.
- Turn off power supplying switch before doing any other work on or inside switch.
- Do not use renewable link fuses in fused switches.

Failure to follow these instructions will result in death or serious injury.

⚠ DANGER

HAZARD OF ELECTRIC SHOCK, EXPLOSION, OR ARC FLASH

For 208 and 230 V units:

- Apply appropriate personal protective equipment (PPE) and follow safe electrical work practices. See NFPA 70E - Standard for Electrical Safety Requirements for Employee Workplaces and OSHA Standards - 29 CFR Part 1910 Subpart S Electrical, or CSA Z462.
- This equipment must be installed and serviced only by qualified electrical personnel.
- Turn off all power supplying this equipment before working on or inside the equipment.
- Always use a properly rated voltage sensing device to confirm power is off.
- Replace all devices, doors and covers before turning on power to this equipment.

Failure to follow these instructions will result in death or serious injury.

⚠ DANGER

UNINTENDED EQUIPMENT OPERATION

Before turning on the drive or upon exiting the configuration menus, ensure that the inputs assigned to the Run command are in a state that will not cause the drive to run. Otherwise, the motor can start immediately.

Failure to follow these instructions will result in death, or serious injury.

⚠ WARNING

LOSS OF CONTROL

- The designer of any control scheme must consider the potential failure modes of control paths and, for certain critical control functions, provide a means to achieve a safe state during and after a path failure. Examples of critical control functions are emergency stop and overtravel stop.
- Separate or redundant control paths must be provided for critical control functions.
- System control paths may include communication links. Consideration must be given to the implications of anticipated transmission delays or failures of the link¹.
- Each implementation of an S-Flex enclosed drive must be individually and thoroughly tested for proper operation before being placed into service.

Failure to follow these instructions can result in death, serious injury, or equipment damage.

¹ For additional information, refer to NEMA ICS 1.1 (latest edition), "Safety Guidelines for the Application, Installation, and Maintenance of Solid State Control" and to NEMA ICS 7.1 (latest edition), "Safety Standards for Construction and Guide for Selection, Installation and Operation of Adjustable-Speed Drive Systems."

⚠ CAUTION

INCOMPATIBLE LINE VOLTAGE

Before turning on and configuring the drive, ensure that the line voltage is compatible with the line voltage range specified on the drive nameplate. The drive can be damaged if the line voltage is not compatible.

Failure to follow these instructions can result in injury or equipment damage.

Catalog Number Description

The catalog number, located on the nameplate attached to the S-Flex drive, is coded to describe the configuration of the drive. See Figure 1 on page 12 for an example of the S-Flex nameplate.

Use Table 2 to translate the catalog number into a description of the drive. The following example translates the catalog number shown on the nameplate in Figure 1 on page 12.

Table 1: Catalog Number Example: SFD212CG4YX07

Field				
01	02	03	04	05
SFD212	C	G	4	Y
	1 hp	Type 1 General Purpose	460 Vac	Full Voltage Bypass

Table 2: Catalog Number Description

Field	Digit	Characteristic	Description
01	01 – 05	Controller Style	SFD212 = S-Flex 212 Enclosed Drive
02	06	Horsepower	C = 1 hp D = 2 hp E = 3 hp F = 5 hp G = 7.5 hp H = 10 hp J = 15 hp K = 20 hp L = 25 hp M = 30 hp N = 40 hp P = 50 hp (460 V only) Q = 60 hp (460 V only) R = 75 hp (460 V only) S = 100 hp (460 V only)
03	07	Enclosure Type	G = Type 1 General Purpose
04	08	Voltage	2 = 208 Vac 3 = 230 Vac 4 = 460 Vac
05	09	Power Circuit	W = Without Bypass Y = Full Voltage Bypass
06	010 – 012	Communication Set-Up Options	A06 = BACnet Card B06 = LonWorks® Card C06 = Metasys® N2 Card D06 = Apogee™ P1 Card N06 = Modbus
07	013 – 015	Miscellaneous Options	A07 = Drive Input Disconnect ¹ B07 = Line Contactor ¹ S07 = Seismic Certification D07 = Full Text Keypad X07 = AC Line Reactor

¹ Options A07 Drive Input Disconnect and B07 Line Contactor are available only when a full voltage bypass (Y05) option is selected. Options A07 and B07 are mutually exclusive.

Nameplate Identification

The nameplate for the S-Flex enclosed drive is located on the inside of the door. See Figure 1. The nameplate identifies the drive type and modification options. When identifying or describing the S-Flex enclosed drive, use the data from the nameplate.

Figure 1: S-Flex 212 Nameplate Example

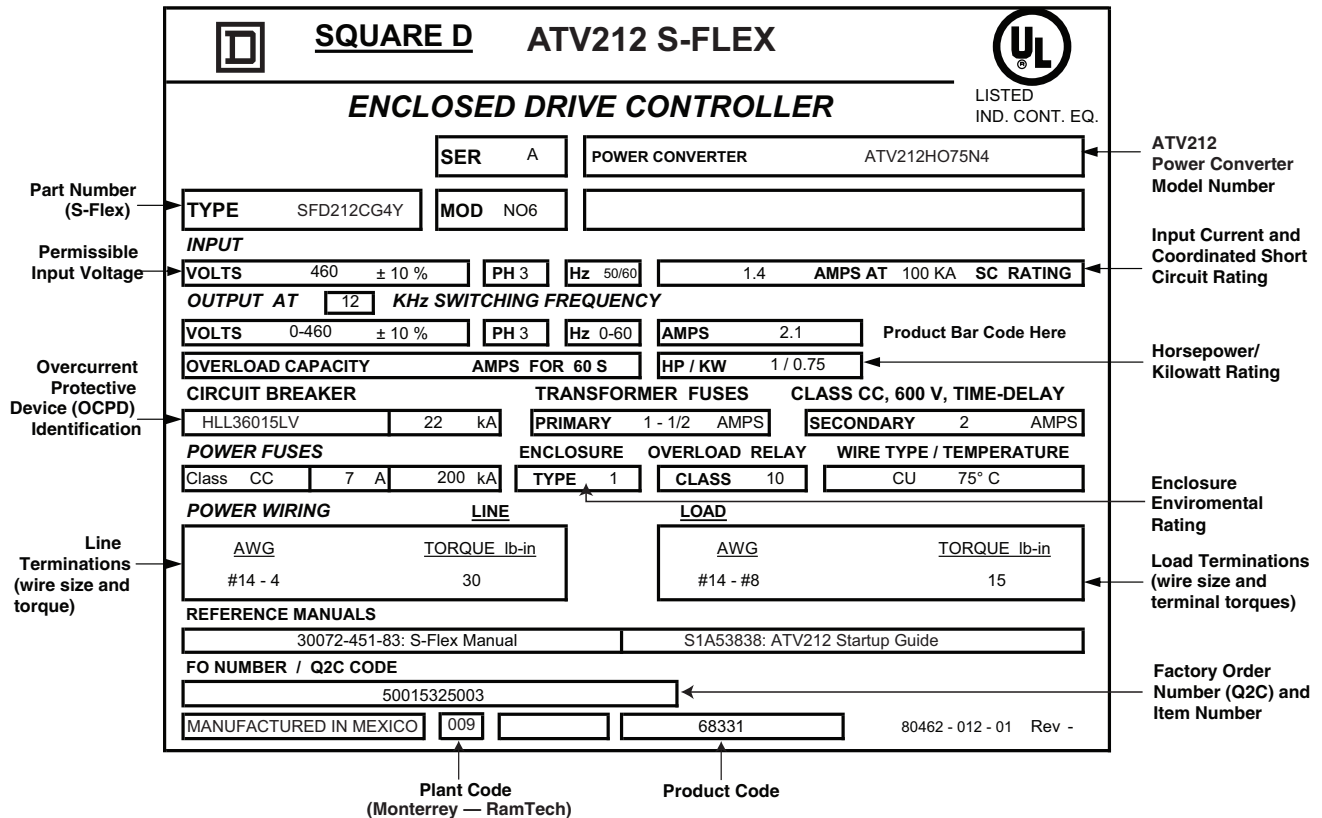

Technical Characteristics

Table 3: Variable Torque Ratings

S-Flex Catalog Number ¹	Input Voltage 60 Hz (Vac)	Horse-power Rating (hp) ²	Kilowatt Rating (kW)	Input Current (A) ³	Output Current (A) ²	Max. Transient Output Current 60 s (A) ²	Total Dissipated Power at Rated Load (W) ^{2, 4}	Power Converter Part Number ⁵
SFD212CG2•	208	1	0.75	3.3	4.8	5.1	184.2	ATV212H075M3X
SFD212DG2•		2	1.5	6.1	7.8	8.3	228.3	ATV212HU15M3X
SFD212EG2•		3	2.2	8.7	11	11.7	256.0	ATV212HU22M3X
SFD212FG2•		5	4	15.7	17.5	19.3	326.8	ATV212HU40M3X
SFD212GG2•		7.5	5.5	20.8	25.3	26.6	384.7	ATV212HU55M3X
SFD212HG2•		10	7.5	27.9	32.2	35.2	495.0	ATV212HU75M3X
SFD212JG2•		15	11	42.1	48.3	50.8	641.2	ATV212HD11M3X
SFD212KG2•		20	15	56.1	62.1	67.1	846.1	ATV212HD15M3X
SFD212LG2•		25	18.5	67.3	78.2	82.3	939.1	ATV212HD18M3X
SFD212MG2•		30	22	80.4	92	96.8	1017.6	ATV212HD22M3X
SFD212NG2•		40	30	113.3	120	128.7	1414.3	ATV212HD30M3X
SFD212CG3•		230	1	0.75	2.8	4.2	5.1	183.1
SFD212DG3•	2		1.5	5.3	6.8	8.3	226.1	ATV212HU15M3X
SFD212EG3•	3		2.2	7.6	9.6	11.7	252.1	ATV212HU22M3X
SFD212FG3•	5		4	13.5	15.2	19.3	323.5	ATV212HU40M3X
SFD212GG3•	7.5		5.5	18.1	22	26.6	381.0	ATV212HU55M3X
SFD212HG3•	10		7.5	24.4	28	35.2	489.1	ATV212HU75M3X
SFD212JG3•	15		11	35.7	42	50.8	630.6	ATV212HD11M3X
SFD212KG3•	20		15	47.6	54	67.1	829.5	ATV212HD15M3X
SFD212LG3•	25		18.5	58.0	68	82.3	918.3	ATV212HD18M3X
SFD212MG3•	30		22	69.0	80	96.8	994.1	ATV212HD22M3X
SFD212NG3•	40		30	93.0	104	128.7	1378.4	ATV212HD30M3X
SFD212CG4•	460		1	0.75	1.4	2.1	2.4	173.1
SFD212DG4•		2	1.5	2.5	3.4	4	197.6	ATV212HU15N4
SFD212EG4•		3	2.2	4.9	4.8	5.6	224.7	ATV212HU22N4
SFD212FG4•		5	4	6.4	7.6	10	303.6	ATV212HU40N4
SFD212GG4•		7.5	5.5	8.6	11	13.2	352.5	ATV212HU55N4
SFD212HG4•		10	7.5	11.7	14	17.6	418.8	ATV212HU75N4
SFD212JG4•		15	11	16.9	21	24.8	572.9	ATV212HD11N4
SFD212KG4•		20	15	22.6	27	33.6	765.8	ATV212HD15N4
SFD212LG4•		25	18.5	27.8	34	40.7	766.5	ATV212HD18N4
SFD212MG4•		30	22	33.1	40	47.9	806.0	ATV212HD22N4
SFD212NG4•		40	30	44.7	52	64.4	1041.5	ATV212HD30N4
SFD212PG4•		50	37	54.4	65	86.9	1241.6	ATV212HD37N4
SFD212QG4•		60	45	65.9	77	103.4	1622.1	ATV212HD45N4
SFD212RG4•		75	55	89	96	127.6	2007.5	ATV212HD55N4
SFD212SG4•	100	75	111.3	124	176	2866.8	ATV212HD75N4	

¹ The "*" indicates that the catalog number can end in a "Y" (for an S-flex drive with full voltage bypass) or a "W" (for an S-Flex drive without bypass).

² These power, amperage, and wattage ratings apply to:
Power converters ATV212H075*** to HD15*** (1–20 hp) operating at a switching frequency of 12 kHz, and at 40 °C (104 °F) ambient temperature.
Power converters ATV212HD18*** to HD75*** (25–100 hp @ 460 V) operating at a switching frequency of 8 kHz, and at 40 °C (104 °F) ambient temperature. For a switching frequency between 13 kHz and 16 kHz, select the next largest size drive. If the duty cycle does not exceed 60% (36 s for a 60 s cycle) this is not necessary.

³ Select the conductor based on the input line current or the motor FLA, whichever is greater.

⁴ For btu/hr, multiply values by 3.413.

⁵ Drives shown in the table are installed in SFD212 controllers.

⚠ WARNING

HEAT OR FIRE DAMAGE

- Protective devices must be properly coordinated.
- Do not connect the drive to a power feeder whose short circuit capacity exceeds the short circuit rating listed on the drive nameplate.

Failure to follow these instructions can result in death or serious injury.

Short Circuit Ratings

All configurations have a short-circuit withstand rating of 100,000 A (symmetrical).

Input Current Ratings

All branch circuit components and equipment must be rated for the input current of the drive or the motor full load current (FLA), which ever is greater. Branch circuit components and equipment include: transformers, feeder cables, disconnect devices, and protective devices.

The input current rating is printed on the nameplate. See Figure 1 on page 12. The branch circuit feeder protection must be sized according to NEC Article 430.

Technical Specifications

Table 4: S-Flex 212 Product Specifications

Electrical Specifications	
Input voltage	208 Vac ± 10%, 230 Vac ± 10%, 460 Vac ± 10%
Displacement power factor	Approximately 0.96
Input frequency	50/60 Hz ± 5%
Output voltage	Three-phase output, maximum voltage equal to input voltage
Galvanic isolation	Galvanic isolation between power and control (inputs, outputs, and power supplies)
Frequency range of the power converter	0.5 to 200 Hz (factory setting of 60 Hz maximum)
Current limit	110% of nominal drive full load current (FLA) for 60 s
Switching frequency	Selectable from 6 to 16 kHz factory setting: 12 kHz ¹ 1–20 hp; 8 kHz ² above 25 hp
Speed reference	VIA: 4 to 20 mA, Impedance = 242 Ω or 0 to 10 Vdc, Impedance = 30 kΩ 0 to 20 mA, Impedance = 242 W (reassignable, X-Y range with keypad display) VIB: 0 to +10 V, Impedance = 30 kΩ
Frequency resolution in analog reference	0.0048 Hz (11 bits)
Speed accuracy 20–100% of motor rated torque	+/- 10% of nominal slip without speed feedback
Efficiency	Typically greater than 95%
Reference sample time	2 ms
Acceleration and deceleration ramps	0.1 to 3200 seconds (adjustable in 0.1 s increments)
Motor protection	Class 10 overload protection with bypass in addition to controller internal electronic thermal protection.
Keypad display	Self-diagnostics with status messages. 7-segment LED display (standard) Full text keypad, 8 languages (optional) Also see <i>Altivar 212 Installation Guide</i> , S1A53832
Environmental Specifications	
Storage temperature	-13 to +158 °F (-25 to +70 °C)
Operating temperature	+14 to +104°F (-10 to +40 °C)
Humidity	95% with no condensation or dripping water, conforming to IEC 60068-2-3.
Altitude	3,300 ft. (1000 m) maximum without derating; derate the current by 1% for each additional 330 ft. (100 m) up to 10,000 ft. (3000 m).
Enclosure ³	UL Type 1
Pollution degree	Pollution degree 2 per NEMA ICS-1 and IEC 60664-1
Resistance to vibrations (Power converter only)	According to IEC 60068-2-6: 1.5 mm peak to peak from 3 to 13 Hz 1 g from 13 to 150 Hz
Resistance to shocks (Power converter only)	According to IEC 60068-2: 15 g, 11 ms
Transit test to shock	Conforms to International Safe Transit Association guidelines.
Codes and standards	UL/cUL Listed per UL508C as incorporating Class 10 electronic and electromechanical overload protection. Conforms to applicable NEMA ICS, NFPA, IEC, and ISO 9001 standards. Seismic Certification: • IBC, NFPA 5000 and ASCE7 • ICC ES AC 156 ⁴

¹ Above 12 kHz derate the drive per the graphs in the *Altivar 212 Installation Guide*, S1A53832.

² Above 8 kHz derate the drive per the graphs in the *Altivar 212 Installation Guide*, S1A53832.

³ Plenum rated; suitable for placement in a compartment handling conditioned air.

⁴ Acceptance criteria test protocol with an importance factor of 1.5.

Section 2—Receiving, Handling, and Storing

WARNING

DAMAGED EQUIPMENT

Do not operate or install any S-Flex enclosed drive that appears damaged.

Failure to follow these instructions can result in death, serious injury, or equipment damage.

Receiving and Preliminary Inspection

Before shipment from the factory, each S-Flex enclosed drive is inspected visually, electrically, and mechanically by professional quality-control analysts. Certification of quality control testing is available upon request.

The S-Flex enclosed drive must be thoroughly inspected before it is stored or installed. Upon receipt:

1. Remove the S-Flex enclosed drive from its packaging and visually inspect the exterior for shipping damage.
2. Ensure that the catalog number of the S-Flex enclosed drive, which appears on the nameplate, agrees with the packing slip and corresponding purchase order. See Figure 1 on page 12.
3. If you find any shipping damage, notify the carrier and your Schneider Electric sales representative.

Storing the Equipment

NOTICE

STACKING DURING STORAGE OR SHIPPING

- Do not stack S-Flex enclosed drives on top of each other.
- Do not place any material on top of the S-Flex enclosed drive.
- Store or ship the S-Flex enclosed drive in the original packaging.

Failure to follow these instructions can result in equipment damage.

If you plan to store the S-Flex enclosed drive after receipt, replace it in its original packaging and store it in a clean, dry area where the ambient temperature is between -13 to +158 °F (-25 to +70 °C).

If the drive must be shipped to another location, use the original shipping material and carton to help protect the drive.

NOTE: Storing the equipment in its original packaging until it reaches its final installation site helps protect the equipment and helps prevent damage to its exterior.

Unpacking the Drive

⚠ WARNING

HEAVY EQUIPMENT

- Lifting the S-Flex enclosed drive requires the use of a lifting apparatus or two people.
- Always use safe lifting practices.

Failure to follow these instructions can result in death, serious injury, or equipment damage.

Handle the S-Flex enclosed drive carefully to avoid damage to the internal components, frame, and exterior. Lift the S-Flex enclosed drive out of its shipping carton, lifting with two people or a suitable lifting apparatus, and place it on a flat surface.

Before Installing the Drive

Before installing the S-Flex enclosed drive, visually verify that all components are properly seated, securely fastened, and undamaged.

1. Unlatch and open the door of the enclosed drive.
2. Visually verify that:
 - All internally mounted hardware and terminal connection hardware is properly seated, securely fastened, and undamaged.
 - The control transformer fuses are in place in the fuse block.
3. Close and latch the S-Flex enclosed drive door.

Handling the Drive

⚠ WARNING

HANDLING AND LIFTING HAZARD

- Keep the area below any equipment being lifted clear of all personnel and property.
- Lifting the S-Flex enclosed drive requires the use of a lifting apparatus and two people. Use the lifting method shown in Figure 2 on page 19.
- Before lifting the drive:
 - Inspect the lifting plates, holes, slots, and eyebolts for any damage.
 - Attach a spreader bar.
 - Keep the lifting force vertical.
 - Limit the swing angle to less than 45°.

Failure to follow these instructions can result in death, serious injury, or equipment damage.

When handling drives:

- Always work with another person. The weight, size, and shape of the drive is such that two people are required to handle it.
- Use gloves.
- Attach a spreader bar to the two top lifting holes on the drive back panel and hoist the controller with chains or straps. See Figure 2 for the proper hoisting method and Figure 3 for the lifting points on the S-Flex enclosed drive.
- Raise the drive from a horizontal position (that is, the back of the controller resting on a pallet).
- Place the drive in an upright position.

NOTE: The bottom of the drive is on an angle.

- Mount the drive on a flat, solid, noncombustible vertical surface, capable of supporting the controller weight.
- Secure all four corners of the controller with hardware of a sufficient size and type capable of supporting the controller weight.

Figure 2: Hoisting the S-Flex Drives

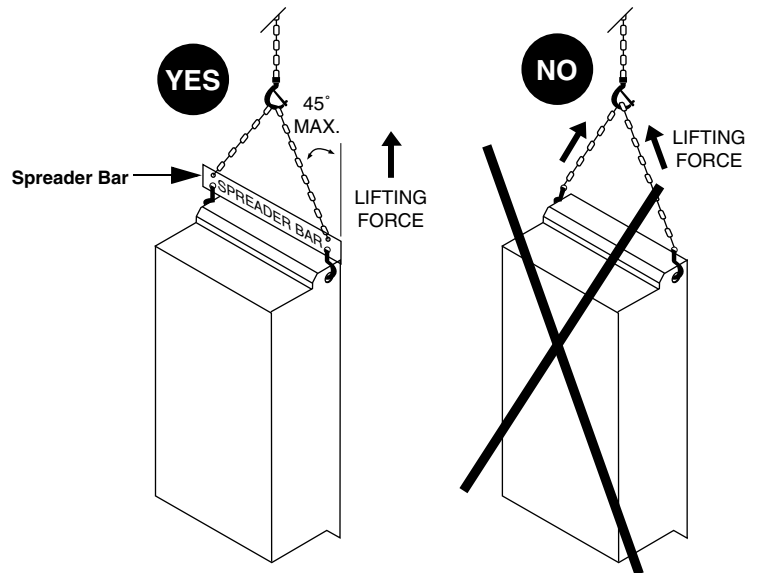
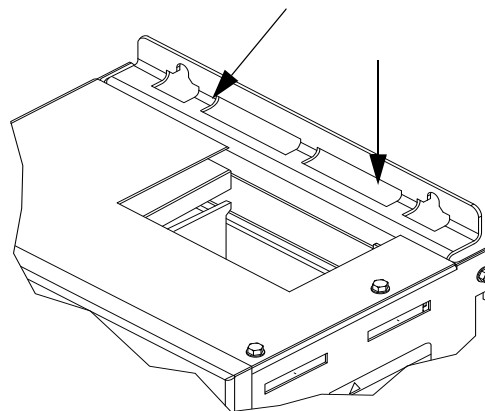

Figure 3: Lifting Points on the S-Flex Drives



Section 3—Installation and Start-up

Installation Guidelines

⚠ DANGER
<p>HAZARD OF ELECTRIC SHOCK, EXPLOSION, OR ARC FLASH</p> <p>Read and understand the precautions in “Before You Begin” starting on page 8 before performing the procedures in this section.</p> <p>Failure to follow these instructions will result in death or serious injury.</p>

Follow these precautions when installing the S-Flex enclosed drive:

- The drive is suitable for installation in a pollution degree 2 environment, as defined in NEMA ICS1 and IEC 60664-1.
- When attaching wall-mountable drives to their mounting surfaces, use fasteners rated for the weight of the drive, the expected shock and vibration of the installation, and the expected environment. See Tables 5–7 on page 22 for S-Flex enclosed drive weights.
- Provide sufficient cooling for the expected heat load. See Table 3 on page 13 for dissipated power at rated load.
- Do not mount the controller in direct sunlight or on hot surfaces. Mount it on a solid, flat surface only.

Drive Weights

Table 5: 460 V S-Flex 212 Weights

Catalog Number ¹	Hp	Weight lb (kg) ²	Weight w/Mod X07 lb (kg)
SFD212CG4•	1	52 (23.5)	83 (37.7)
SFD212DG4•	2	52 (23.5)	83 (37.7)
SFD212EG4•	3	52 (23.5)	83 (37.7)
SFD212FG4•	5	52 (23.5)	83 (37.7)
SFD212GG4•	7.5	52 (23.5)	83 (37.7)
SFD212HG4•	10	52 (23.5)	83 (37.7)
SFD212JG4•	15	52 (23.5)	83 (37.7)
SFD212KG4•	20	111 (50.3)	133 (60.33)
SFD212LG4•	25	111 (50.3)	133 (60.33)
SFD212MG4•	30	140 (63.5)	223 (101.2)
SFD212NG4•	40	140 (63.5)	223 (101.2)
SFD212PG4•	50	140 (63.5)	223 (101.2)
SFD212QG4•	60	140 (63.5)	223 (101.2)
SFD212RG4•	75	206 (93.4)	278 (126)
SFD212SG4•	100	206 (93.4)	278 (126)

Table 6: 230 V S-Flex 212 Weights

Catalog Number ¹	Hp	Weight lb (kg) ²	Weight w/Mod X07 lb (kg)
SFD212CG3•	1	52 (23.5)	83 (37.7)
SFD212DG3•	2	52 (23.5)	83 (37.7)
SFD212EG3•	3	52 (23.5)	83 (37.7)
SFD212FG3•	5	52 (23.5)	83 (37.7)
SFD212GG3•	7.5	52 (23.5)	83 (37.7)
SFD212HG3•	10	52 (23.5)	83 (37.7)
SFD212JG3•	15	111 (50.3)	133 (60.33)
SFD212KG3•	20	111 (50.3)	133 (60.33)
SFD212LG3•	25	111 (50.3)	133 (60.33)
SFD212MG3•	30	140 (63.5)	223 (101.2)
SFD212NG3•	40	206 (93.4)	278 (126)

Table 7: 208 V S-Flex 212 Weights

Catalog Number ¹	Hp	Weight lb (kg) ²	Weight w/Mod X07 lb (kg)
SFD212CG2•	1	52 (23.5)	83 (37.7)
SFD212DG2•	2	52 (23.5)	83 (37.7)
SFD212EG2•	3	52 (23.5)	83 (37.7)
SFD212FG2•	5	52 (23.5)	83 (37.7)
SFD212GG2•	7.5	52 (23.5)	83 (37.7)
SFD212HG2•	10	52 (23.5)	83 (37.7)
SFD212JG2•	15	111 (50.3)	133 (60.33)
SFD212KG2•	20	111 (50.3)	133 (60.33)
SFD212LG2•	25	111 (50.3)	133 (60.33)
SFD212MG2•	30	140 (63.5)	223 (101.2)
SFD212NG2•	40	206 (93.4)	278 (126)

¹ The “•” indicates that the catalog number can end in a “Y” (for an S-flex drive with full voltage bypass) or a “W” (for an S-Flex drive without bypass). Catalog numbers shown are for SFD212 controller style drives.

² The weight varies depending on modification options.

Center of Gravity

Center of gravity information is provided for reference in mounting and for consideration in structural analysis.

Dimensions for Wall or Panel Mounting

Figure 4: Frame Size A: 1–10 hp, 208/230 Vac and 1–15 hp, 460 Vac

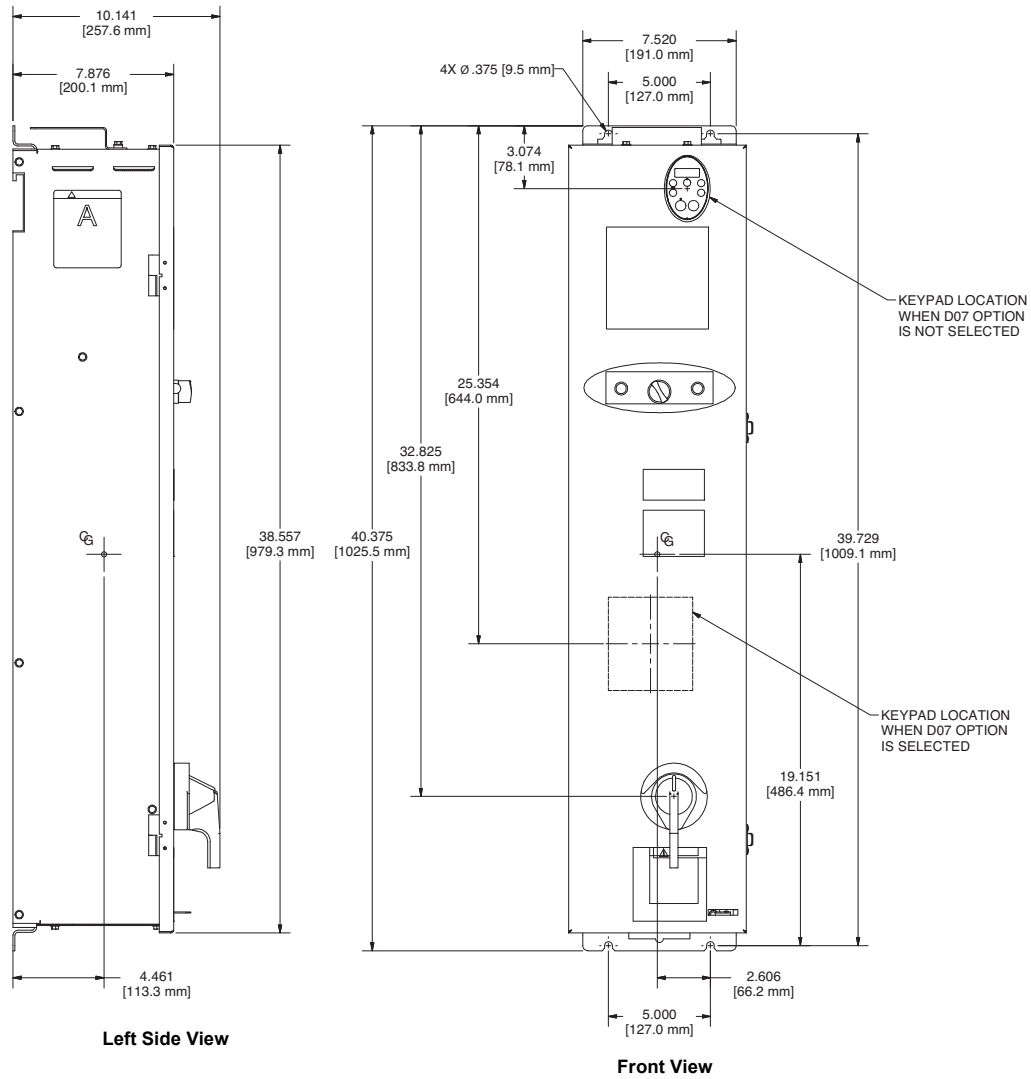

Dimensions: Inches [mm]

NOTE: Standard Bypass control package is shown.

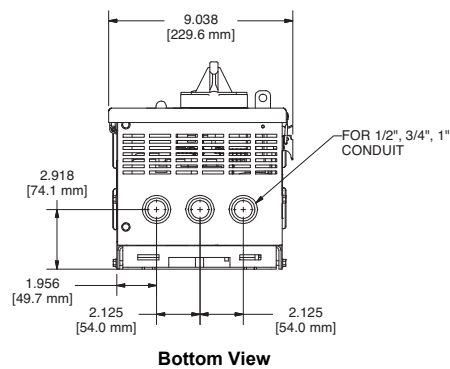
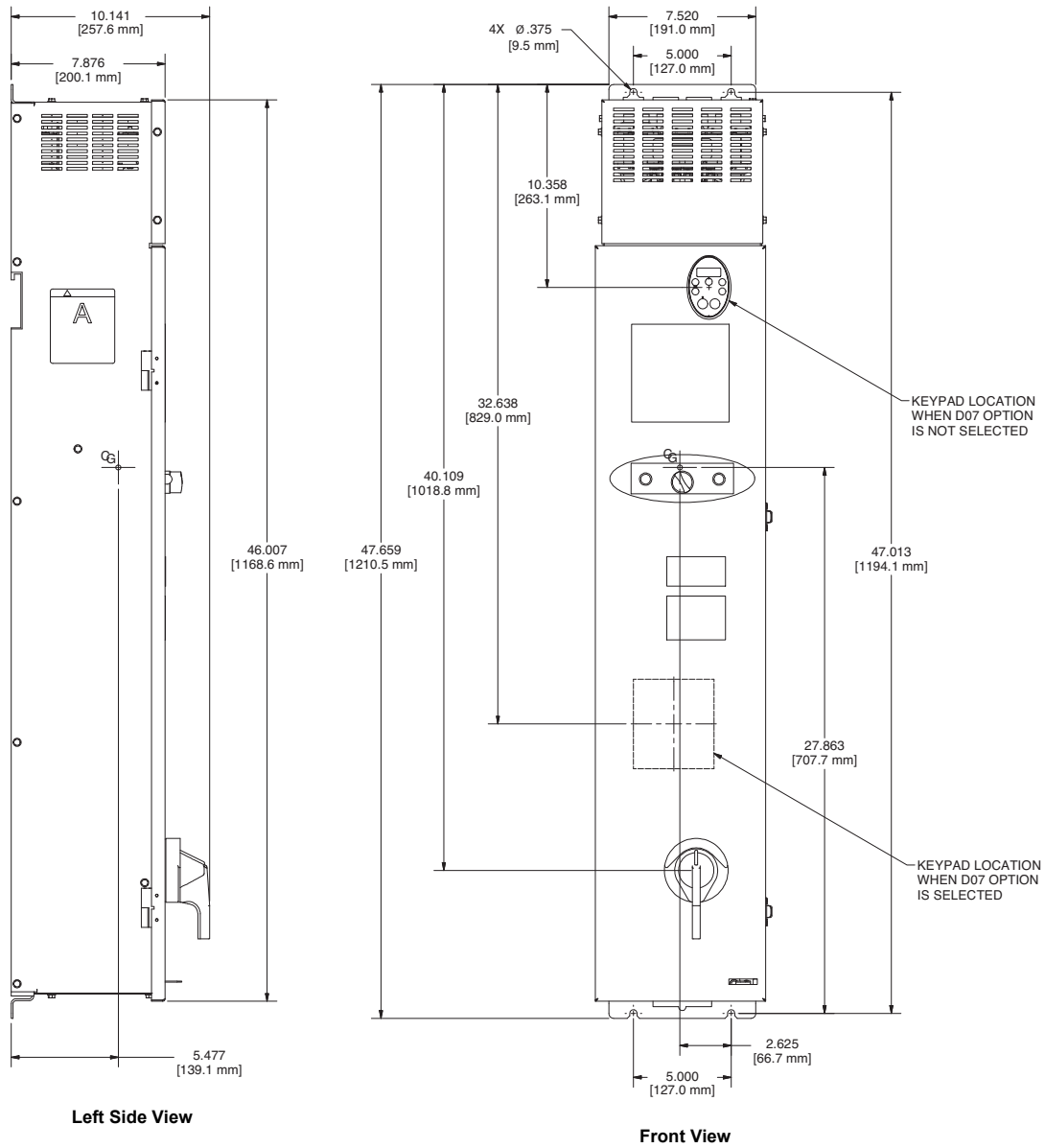

Figure 5: Frame Size A: 1–10 hp, 208/230 Vac and 1–15 hp, 460 Vac with Line Reactor



Dimensions: Inches
 [mm]

NOTE: Standard Bypass control package is shown.

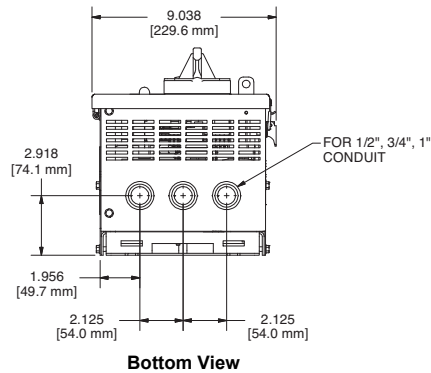
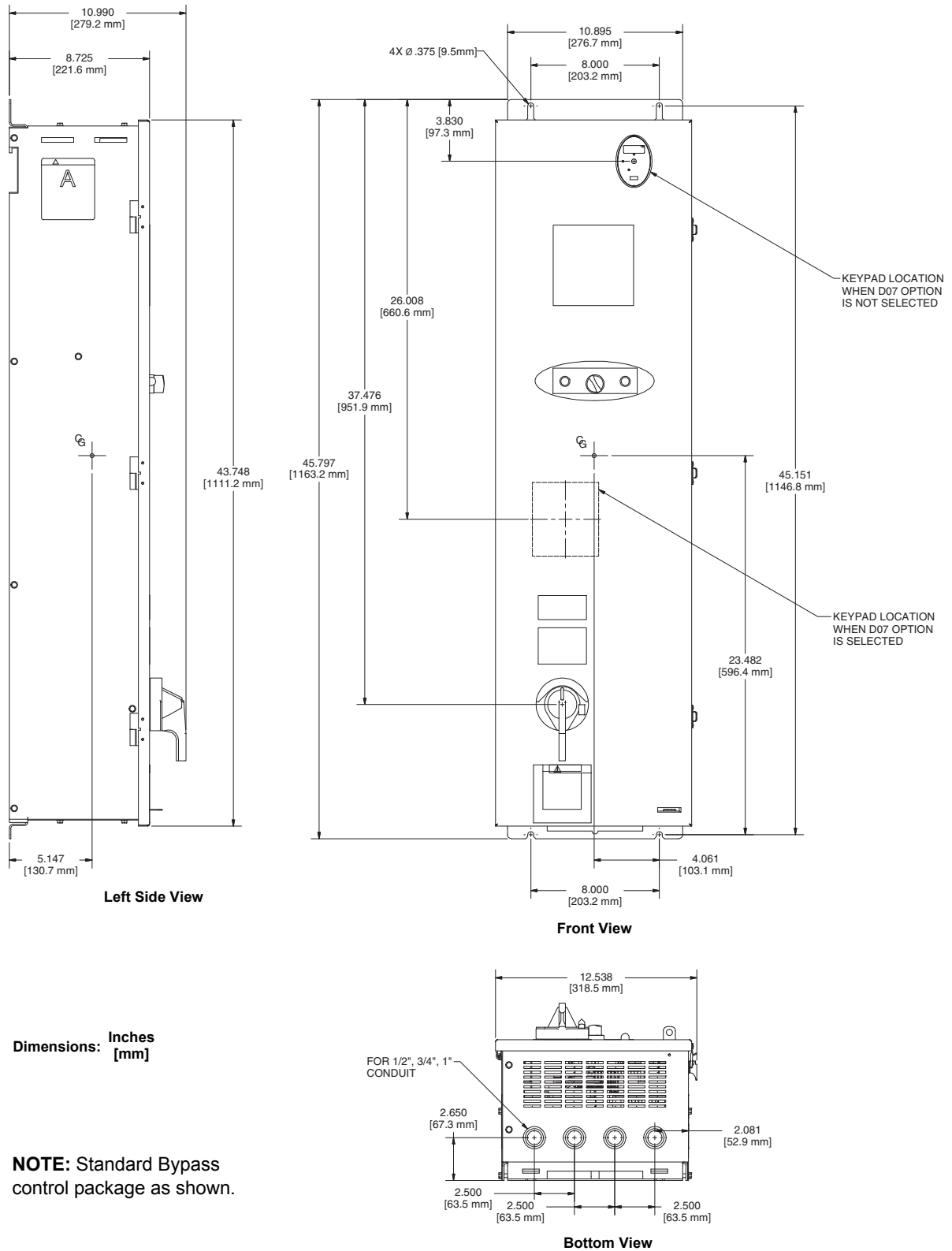

Figure 6: Frame Size B: 15–25 hp, 208/230 Vac and 20–25 hp, 460 Vac



Dimensions: Inches [mm]

NOTE: Standard Bypass control package as shown.

Figure 7: Frame Size B: 15–25 hp, 208/230 Vac and 20–25 hp, 460 Vac, with Line Reactor

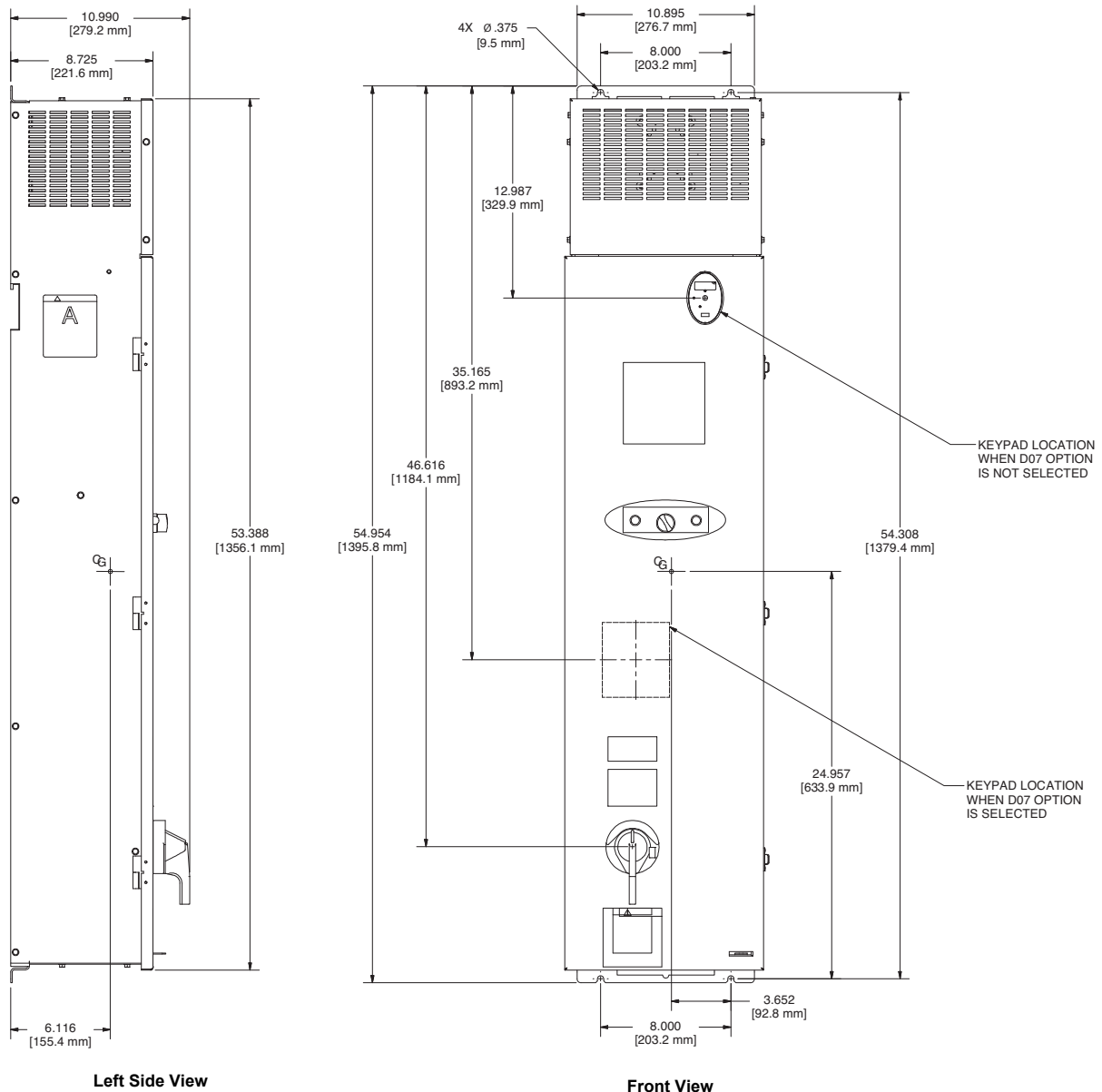

Dimensions: Inches
 [mm]

NOTE: Standard Bypass control package as shown.

Figure 8: Frame Size C: 30 hp, 208/230 Vac and 30–60 hp, 460 Vac

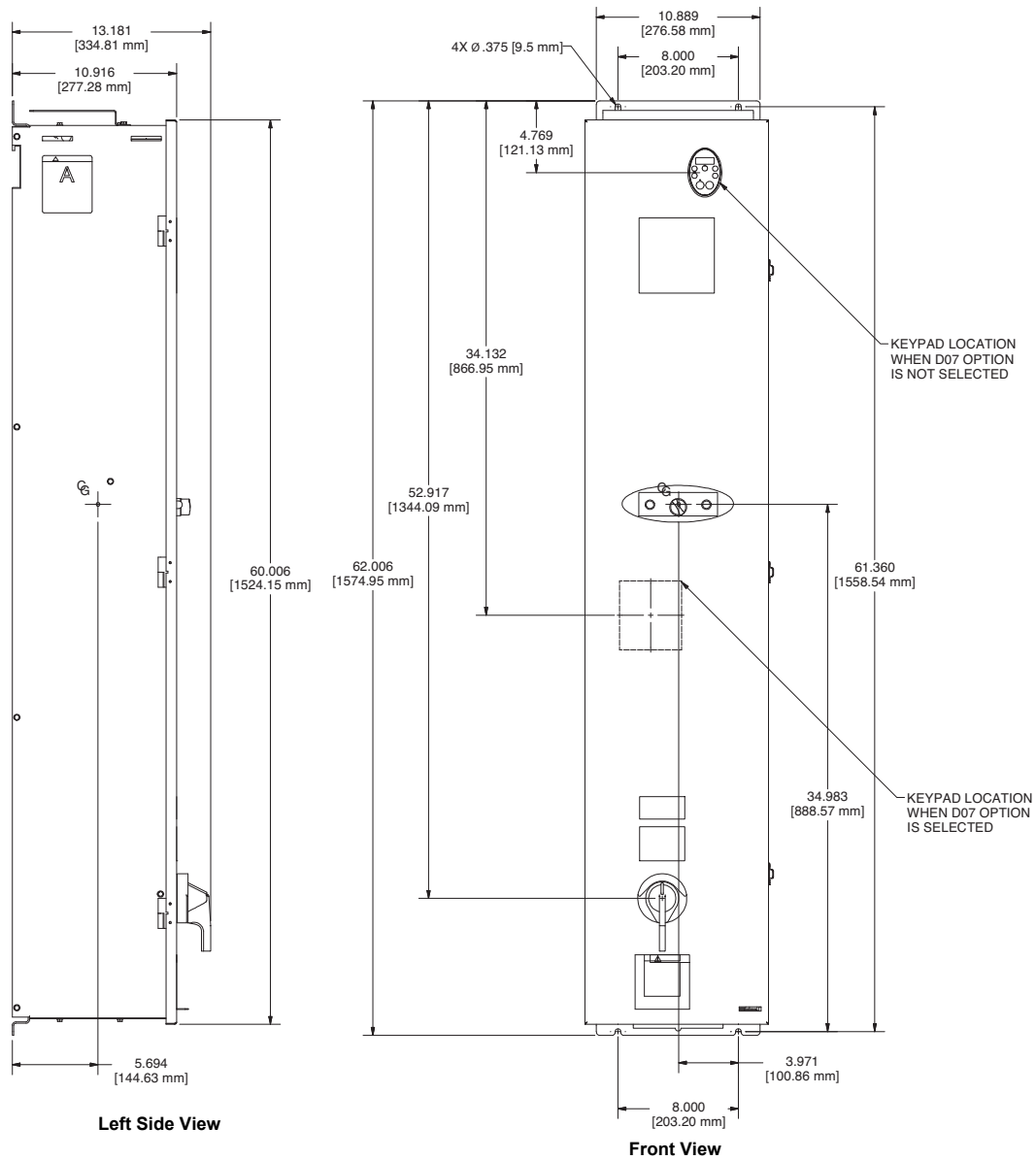

Dimensions: Inches [mm]

NOTE: Standard Bypass control package as shown.

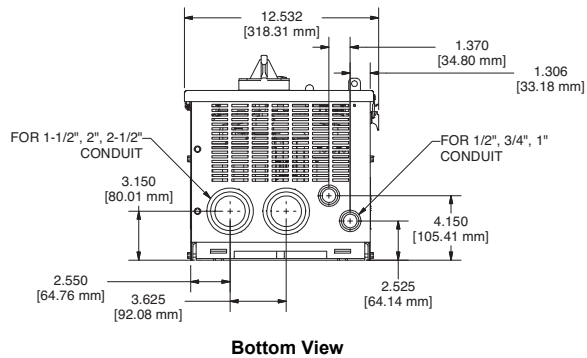
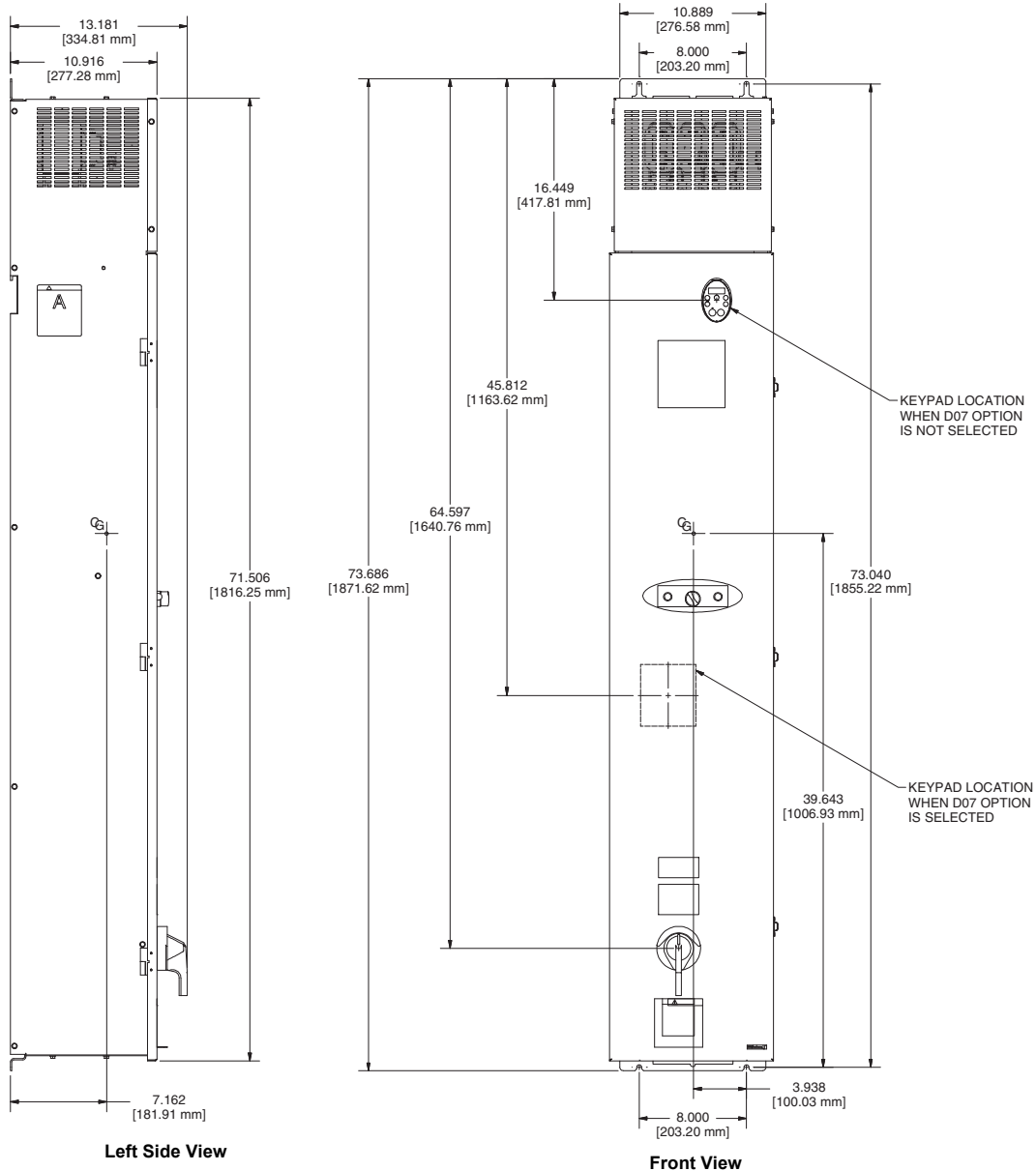

Figure 9: Frame Size C: 30 hp 208/230 Vac and 30–60 hp 460 Vac, with Line Reactor



Dimensions: Inches [mm]

NOTE: Standard Bypass control package as shown.

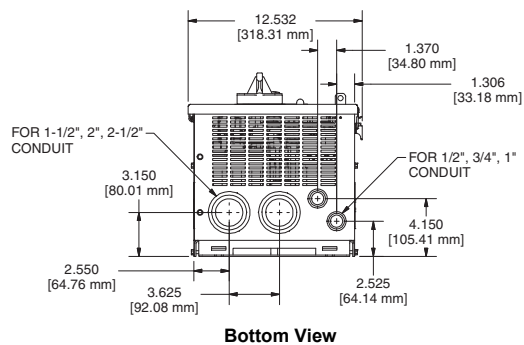

Figure 10: Frame Size D: 40 hp, 208/230 Vac; 75–100 hp, 460 Vac

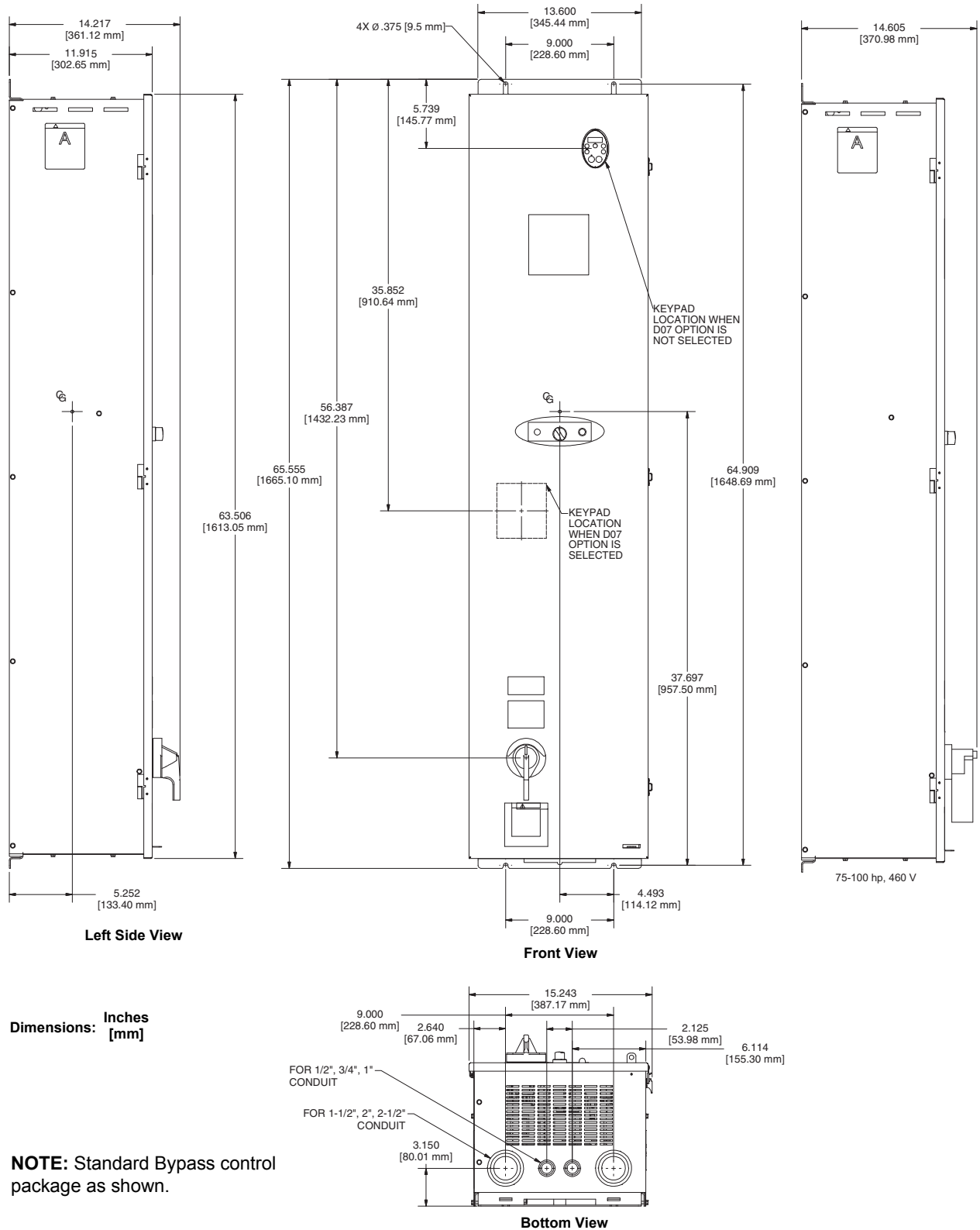
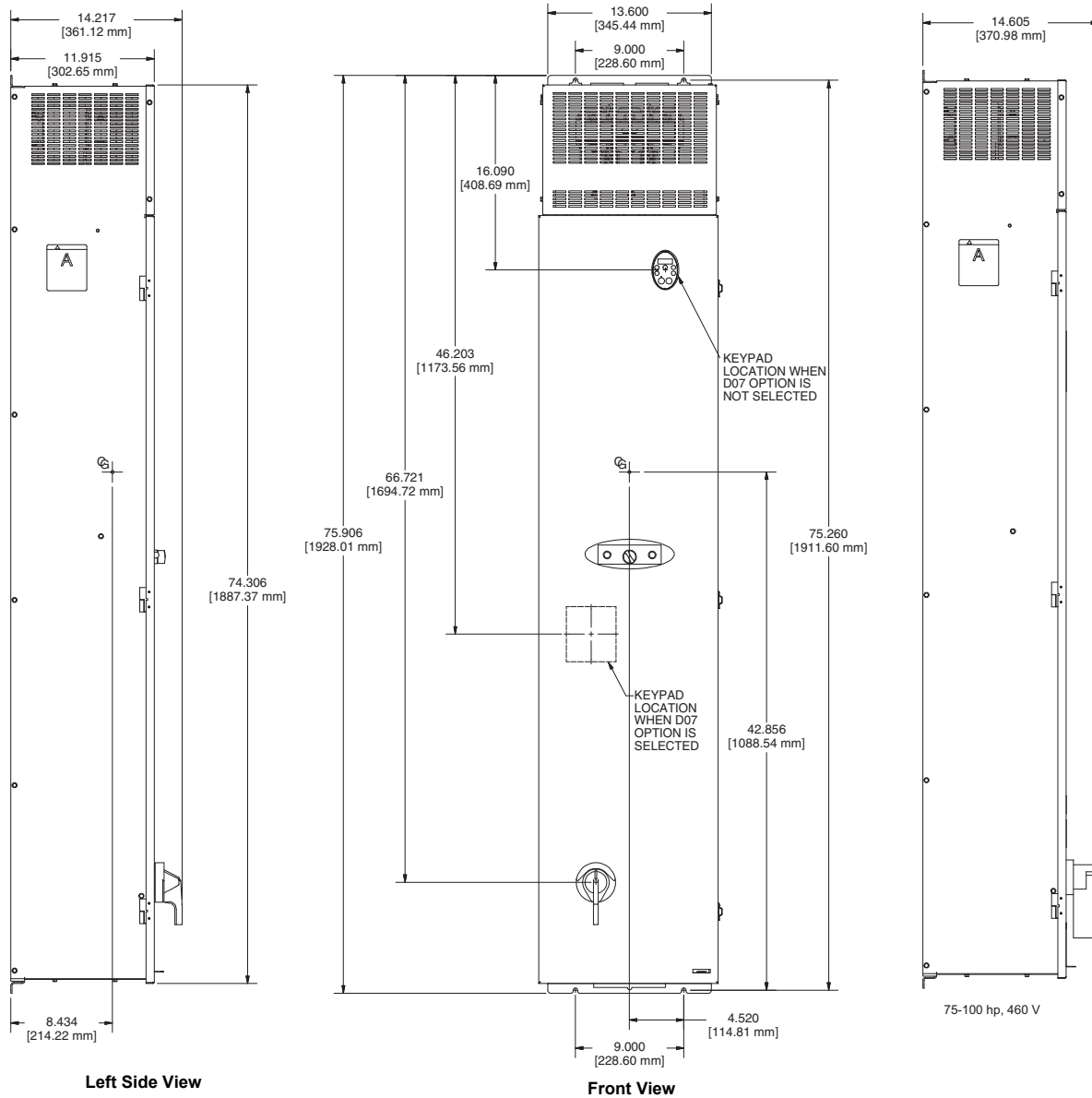
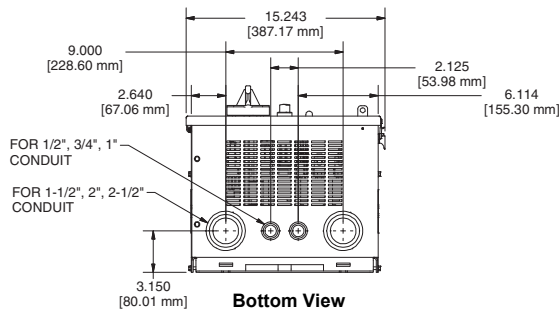

Figure 11: Frame Size D: 40 hp, 208/230 Vac; 75–100 hp 460 Vac, with Line Reactor



Dimensions: Inches
 [mm]

NOTE: Standard Bypass control package as shown.



Mounting Requirements

⚠ WARNING

IMPROPER MOUNTING

Before removing the lifting mechanism:

- Ensure that all hardware is of sufficient size and type for the controller weight.
- Secure and tighten all hardware.
- If using knockouts for conduit entry, exercise care to prevent metal or chips from falling on parts and electronic printed wiring boards.
- When cleaning the interior and exterior of the controller, use a vacuum. Do not use compressed air, as it may blow contaminants into other parts of the controller.
- Check the enclosure for damage that might reduce electrical clearances.
- See Figures 4–11 on pages 23–30 for mounting dimensions and clearances, and location of conduit entry areas.

Failure to follow these instructions can result in death, serious injury, or equipment damage.

Mount each device so that the door can be opened at least 90°. The following are spacing recommendations:

- Mount all units with a minimum of 6.0 in. (152 mm) of space to the top and bottom.
- Mount 1–40 hp 208/230 V and 1–60 hp 460 V units with a minimum of 3.5 in. (89 mm) of space to the left and right.
- Mount 75–100 hp 460 V units with a minimum of 4.0 in. (102 mm) of space to the left and right.

Mounting on an EZM Mounting Channel

This section explains how to mount the drive on an EZM72MC mounting channel. This mounting method is available for:

- Frame Size A Enclosures: 1–15 hp @ 460 V, 1–10 hp @ 208/230 V
- Frame Size B Enclosures: 20–25 hp @ 460 V, 15–25 hp @ 208/230 V
- Frame Size C Enclosures: 30–60 hp @ 460 V, 30 hp @ 208/230 V

NOTE: EZM mounting cannot meet seismic requirements. Normal mounting methods must be used to meet seismic requirements.

The EZM channel is used to mount enclosures or assist in the alignment of multiple enclosures. Observe the following requirements for EZM mounting:

- Securely fasten the EZM mounting channel to a wall that is rated to support the total weight of the drives.
- Add additional wall anchor points to the EZM mounting channel as follows, with consideration given to wall construction:
 - **Frame Size A enclosures only:** For a 72 in. long rail with a maximum of six size A drives, do not locate the rail anchor points more than 6 in. from each end, and do not allow more than 20 in. between each additional anchor point.

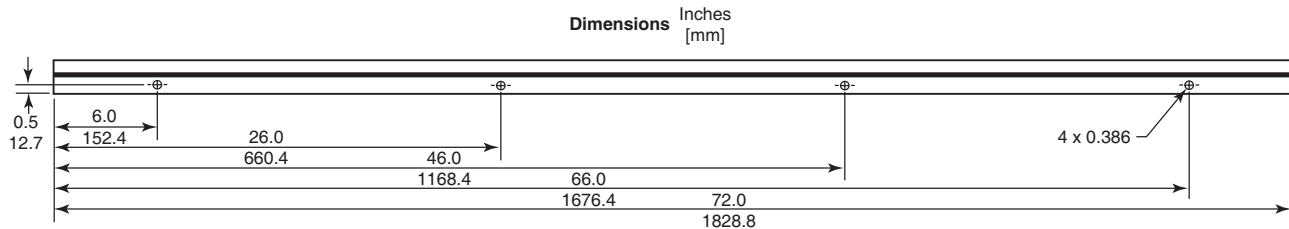

- **Frame Size B and C enclosures:** For a 72 in. long rail with a maximum of four size B or C drives (or any combination of these drives), do not locate the rail anchor points more than 3 in. from each end, and do not allow more than 11 in. between each additional anchor point.

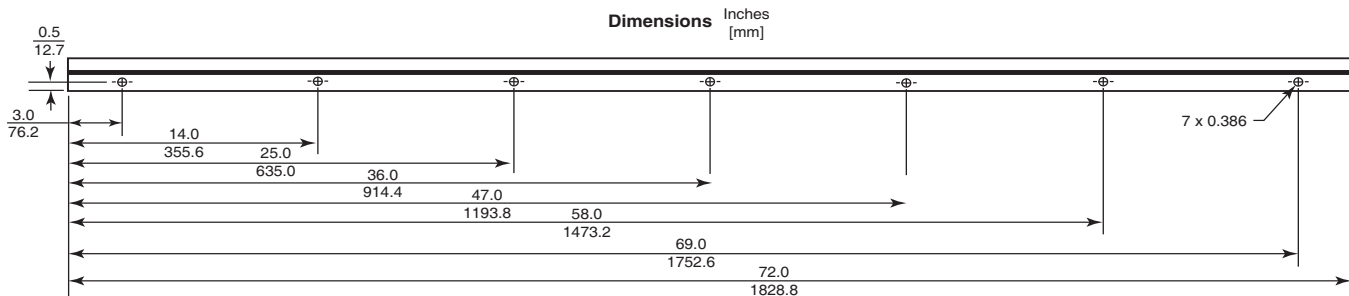

- Use SAE grade 5-3/8 in. or better hardware to secure the rail to the wall. Use additional anchor hardware if needed for the material used in the wall construction.
- Add additional 5/16 in. hardware to the bottom flange of the enclosure. See Figure 12.

Figure 12: EZM Mounting Hardware

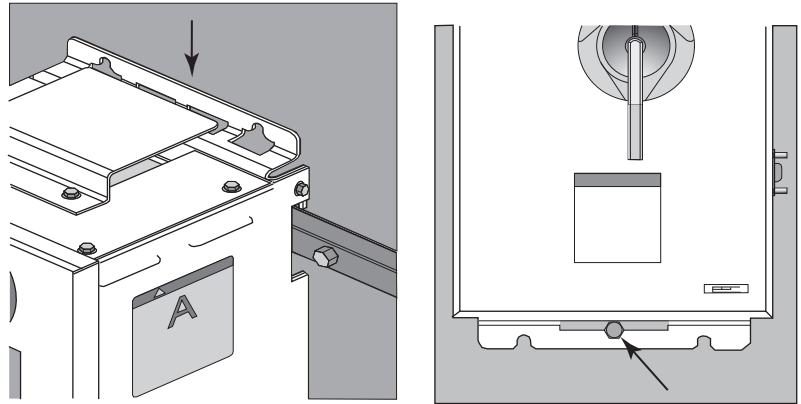

Seismic Qualification Mounting Criteria

Seismic qualification (MOD S07) harmonizes the following standards in compliance to ICC ES AC156 acceptance criteria test protocol with an importance factor of 1.5:

- IBC (International Building Code)
- NFPA 5000 (Building Code-National Fire Protection Agency)
- CBC (Canadian Building Code)
- ASCE/SEI 7 (American Society of Civil Engineers)
- California Building Code
- California Office of Statewide Health Planning

For seismic rating installation compliance:

- Follow the anchorage and mounting guidelines on the seismic qualification labels attached to the controller (see Figures 4–6 on pages 23–25).
- Use SAE Grade 5 bolts and washers.
- Torque all bolts to applicable SAE standards for grade 5 hardware, considering all plating and lubricant factors.

For additional information on Seismic qualification of enclosed drives, refer to instruction bulletin 30072-454-87, *Seismic Qualification of Enclosed Drives and Soft Starters*.

Figure 13: Seismic Qualification Labels

Certification Label	Wall Mounting
<div style="border: 1px solid black; padding: 10px;"> <p style="font-size: 24pt; font-weight: bold; margin: 0;">SEISMIC QUALIFIED</p> <p style="margin: 5px 0;">2003 IBC NFPA 5000 2001 CBC 1997 UBC 1999 NBC 1999 SBC ASCE-7 02</p> <div style="text-align: center; margin: 10px 0;"> </div> <p style="font-size: 10pt; margin: 0;">80438-880-04 REV -</p> </div>	<div style="border: 1px solid black; padding: 10px;"> <div style="display: flex; align-items: center;"> <div style="margin-left: 20px;"> <p>Seismic Anchorage Requirements</p> <ul style="list-style-type: none"> ■ Seismic Anchorage Location </div> </div> <p style="font-size: 8pt; margin-top: 10px;">To maintain Seismic Qualification each individual enclosure must be anchored to wall at all five mounting locations shown above. Refer to the current International Building Code or NFPA 5000 for location specific values of Ss. Use 5/16" grade 5 bolts and the appropriate flat washers. In order to develop full strength of the anchor, torque bolts to the value specified by the anchor manufacturer.</p> <p style="font-size: 8pt; margin-top: 5px;">Refer to Instruction Manual 30072-451-83 for installation instructions.</p> <p style="font-size: 8pt; text-align: right; margin-top: 10px;">80462-041-01 Rev -</p> </div>

Electrical Installation

⚠ DANGER

HAZARD OF ELECTRIC SHOCK, EXPLOSION, OR ARC FLASH

Turn off all power (main and remote) before installing the equipment. Refer to “Before You Begin” starting on page 8 for important information and precautions.

Failure to follow these instructions will result in death or serious injury.

General Wiring Practices

Before wiring the drive, perform the DC Bus Voltage Measurement Procedure on page 40. Good wiring practice requires the separation of control circuit wiring from all power wiring. Power wiring to the motor must have the maximum possible separation from all other power wiring, whether from the same drive or other drives.

Do not run power and/or control or multiple power wiring in the same conduit. This separation reduces the possibility of coupling electrical transients from power circuits into control circuits or from motor power wiring into other power circuits.

⚠ CAUTION

IMPROPER WIRING HAZARD

Follow the wiring practices described in this document in addition to those already required by the National Electrical Code® and local codes.

Failure to follow these instructions can result in injury or equipment damage.

Follow the practices below when wiring the S-Flex enclosed drive:

- Use the supplied knockouts to feed control wiring into the cabinet. Do not run control wires through the drive vents or rear air intake.
- Use metallic conduit for all drive wiring. Do not run control and power wiring in the same conduit.
- Separate metallic conduits carrying power wiring or low-level control wiring by at least 3 inches (76 mm).
- Separate existing, non-metallic conduits or cable trays used to carry power wiring from metallic conduit carrying low-level control wiring by at least 12 inches (305 mm).
- Whenever power and control wiring cross, the metallic conduits and non-metallic conduits or trays must cross at right angles.
- Equip all inductive circuits near the controller (relays, contactors, solenoid valves) with noise suppressors.

Input Power

The S-Flex enclosed drive operates from a three-phase supply connected to the input of the controller. The disconnect is coordinated and tested with the controller power circuit for a short circuit current rating of 100,000 A.

Branch Circuit Connections

Size all branch circuit components and equipment such as feeder cables, disconnect devices, and protective devices according to the National Electrical Code and applicable local codes based on the drive input current or motor full load current (whichever is greater).

The input current and drive controller rated FLA are printed on the nameplate (see Figure 1 on page 12). Refer to Table 3 on page 13 for drive controller input currents. Refer to Tables 10 and 11 (page 47) for lug data and wire range of drive controller input terminals L1, L2, and L3.

Connect input power leads L1, L2, and L3 to the input of the circuit breaker or disconnect switch.

Input Wiring

⚠ WARNING

IMPROPER OVERCURRENT COORDINATION

- Properly coordinate all protective devices.
- Do not connect the drive to a power feeder whose short circuit capacity exceeds the short-circuit current rating listed on the drive nameplate.

Failure to follow these instructions can result in death or serious injury.

⚠ CAUTION

EQUIPMENT DAMAGE FROM IMPROPER WIRING

- Do not connect input power leads to the drive output terminals (T1, T2, T3 or U, V, W). This damages the controller and voids the warranty.
- Check the power connections before energizing the controller.

Failure to follow these instructions can result in injury or equipment damage.

Size the ampacity of the input power conductors according to the National Electrical Code and applicable local codes based on the drive input current or motor full load current (whichever is greater).

Grounding

Ground the S-Flex enclosed drive according to the National Electrical Code and all local codes. To ground the drive:

- Connect a copper wire from the grounding bar terminal to the power system ground.
- Verify that the resistance to ground is 1 Ω or less. Improper grounding causes intermittent and unreliable operation.
- Do not remove any internal ground wires or connections.

⚠ DANGER

HAZARD OF ELECTRIC SHOCK

- Ground equipment using the provided grounding connection point as shown in Figure 16 on page 44. The drive panel must be properly grounded before power is applied.
- Do not use metallic conduit as a grounding conductor.

Failure to follow these instructions will result in death or serious injury.

Ground multiple drives as shown in Figure 14. Use one grounding conductor per device. Do not loop grounding conductors or install them in series.

Figure 14: Grounding Multiple Drives

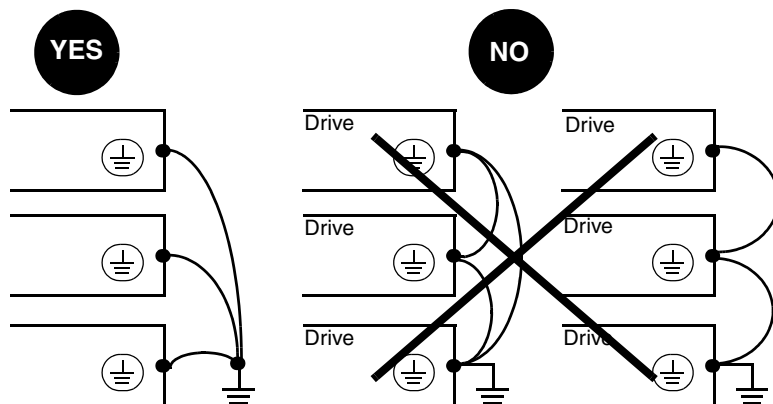

Connection to Ungrounded or High-Resistance Grounded Systems

Altivar 212 480 V drive controllers feature built-in radio frequency interference (RFI) filters with grounded capacitors. When using the drive controller on an ungrounded, resistance grounded, or delta connected system, to isolate the RFI filters from ground to help prevent reduction of their operating life. Refer to the *Altivar 212 Installation Guide*, S1A53832, for information on disconnecting the filter ground.

Wiring and Electromagnetic Compatibility

▲ WARNING

LOSS OF CONTROL

- The designer of any control scheme must consider the potential failure modes of control paths and, for certain critical control functions, provide a means to achieve a safe state during and after a path failure. Examples of critical control functions are emergency stop and over travel stop.
- Separate or redundant control paths must be provided for critical control functions.
- System control paths may include communication links. Consideration must be given to the implications of anticipated transmission delays or failures of the link¹.
- Each implementation of a S-Flex enclosed drive must be individually and thoroughly tested for proper operation before being placed into service.

Failure to follow these instructions can result in death, serious injury, or equipment damage.

¹ For additional information, refer to NEMA ICS 1.1 (latest edition), "Safety Guidelines for the Application, Installation, and Maintenance of Solid State Control" and to NEMA ICS 7.1 (latest edition), "Safety Standards for Construction and Guide for Selection, Installation and Operation of Adjustable-Speed Drive Systems."

The high frequency equipotential grounding connection between the drive, motor, and cable shielding does not eliminate the need to connect the grounding (PE) conductors (green-yellow) to the appropriate terminals on each unit. To help accomplish this, follow these guidelines:

- To avoid communication interference, grounds between the drive, motor and cable shields must have high frequency equipotentiality.
- When using shielded cable for the motor, use a 4-conductor cable so that one wire will be the grounding connection between the motor and the drive. Size the grounding conductor in compliance with local and national codes. The shield can then be grounded at both ends. Metal ducting or conduit can be used for part or all of the shielding length, provided there is no break in continuity.
- When using shielded cable for control signals, if the cable is connecting equipment that is close together and the grounds are bonded together, then both ends of the shield can be grounded. If the cable is connected to equipment that may have a different ground potential, then ground the shield at one end only to prevent large currents from flowing in the shield. The shield on the ungrounded end may be tied to ground with a capacitor (for example: 10 nF, 100V or higher) in order to provide a path for the higher frequency noise.
- Ensure maximum separation between the power supply cable (line supply) and the motor cable and also ensure maximum separation between the control cables and any power cables.

Connecting the motor ground wire directly to the power converter chassis as shown in Figure 15 (page 38) is the preferred grounding method. This method reduces the amount of high frequency noise generated by the power converter PWM that may be coupled into communication or control wiring. The drive has two or more marked terminals for making grounding connections.

Figure 15: Grounding Connection Diagram

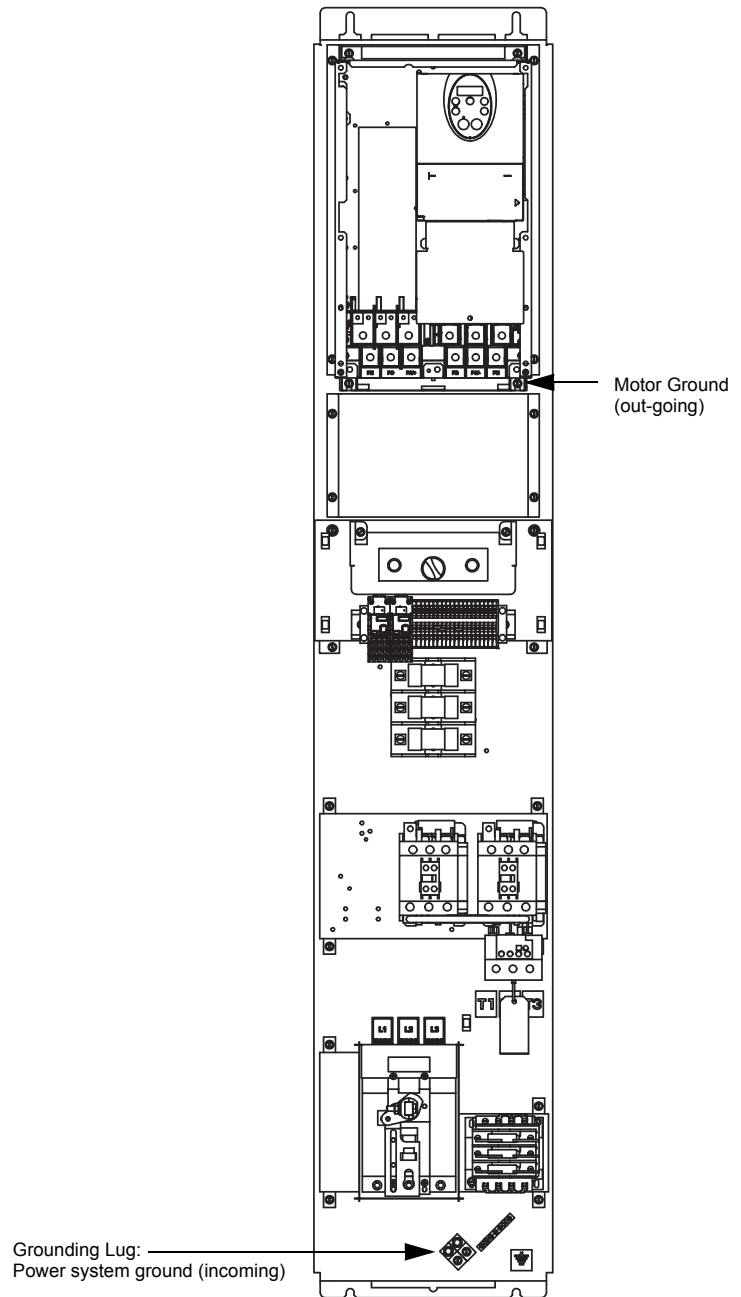

Output Wiring

Size the ampacity of motor power conductors according to the motor full load current, National Electrical Code, and applicable local codes.

Connect motor conductors to the lugs provided and connect the motor ground to the power converter chassis. Connect motor conductors to T1, T2, and T3 on the overload relay when the controller is supplied with a bypass circuit. Connect motor conductors to T1/U, T2/V, and T3/W on the power converter, or T1, T2, and T3 on the distribution block (if supplied), when the controller is supplied without a bypass circuit. See Figure 16 on page 44.

The drive is sensitive to the amount of capacitance (either phase-to-phase or phase-to-ground) present on the output power conductors. If excessive capacitance is present, the drive may trip on overcurrent.

Output Cable

Follow these guidelines when selecting output cable:

- Cable type: select cable with a low capacitance phase-to-phase and to ground. Do not use mineral-impregnated cable because it has a very high capacitance. Immersion of cables in water increases capacitance.
- Cable length: the longer the cable, the greater the capacitance. Cable lengths greater than 164 ft (50 m) may appear as a ground fault condition to the drive. For installations where cable capacitances may be a problem, a reactor or motor protection filter can be installed between the drive and the motor.

The following guidelines are designed to address maximum cable length for typical drive/motor applications.

These limits are based on the maximum recommended peak voltage that can be allowed at the motor terminals, which is due to the reflected wave phenomenon. This increase in voltage is primarily determined by the degree of impedance mismatch between the power conductor and the motor in combination of the dV/dt of the specific semiconductors used in the inverter section of the drive feeding the motor, both of which vary depending on the horsepower involved.

- Many variables can affect the performance of the drive, the motor, and the cables in long lead applications. Motor protection filters can provide substantial benefits when you are using:
 - 460 V or higher rated AC drives
 - Existing general purpose motors subject to retrofit to an AC drive
 - Shielded cables
- NEMA MG-1 Part 31 compliant motors are recommended but not required. However, consult the motor manufacturer or vendor literature to address any specific limitations governing the application.
 - Proximity to other output cables: because of high frequency switching and increased capacitance, the drive may trip under some conditions.
 - **Do not use lightning arrestors or power factor correction capacitors on the output of the drive.**

For proper drive short circuit protection, certain values of inductance may be required in the output power wiring. Inductance can be supplied by the power wiring or auxiliary inductors.

⚠ CAUTION

INSUFFICIENT OUTPUT INDUCTANCE

Provide at least 500 mm (20 in.) of cable at the drive output (U/T1, V/T2, W/T3) to help protect the drive output when short circuits occur.

Failure to follow these instructions can result in injury or equipment damage.

The S-Flex enclosed drive is not intended to be used where extremely long output cable runs are required. Maximum output cable length for standard duty motors should be limited to 100 m (328 ft). For applications exceeding this cable length, consult the factory.

DC Bus Voltage Measurement Procedure

⚠ DANGER

HAZARD OF ELECTRIC SHOCK, EXPLOSION, OR ARC FLASH

- Read and understand the DC Bus Voltage Measurement Procedure before performing the procedure.
- Measurement of bus capacitor voltage must be performed by qualified personnel.
- Apply appropriate personal protective equipment (PPE) and follow safe electrical work practices. See NFPA 70E.
- DO NOT short across terminals PA/+ and PC/- or across the DC bus capacitors.
- DO NOT touch unshielded components or terminal strip screw connections with voltage present.
- Use only electrically insulated tools.
- Before servicing the drive:
 - Disconnect all power including external control power that may be present.
 - Always use a properly rated voltage sensing device to confirm power is off.
 - Place a “DO NOT TURN ON” label on all power disconnects.
 - Lock all power disconnects in the open position.
 - WAIT 15 MINUTES to allow the DC bus capacitors to discharge. Then follow the “DC Bus Voltage Measurement Procedure” below to verify that the DC voltage is less than 42 V. The drive LED is not an indicator of the absence of DC bus voltage.
- Replace all devices, doors and covers before turning on power to this equipment or starting and stopping the drive.

Failure to follow these instructions will result in death or serious injury.

The DC bus voltage level is determined by monitoring the PA/+ and PC/- terminals. The location of these terminals varies by power converter model number. Read the model number of the power converter from the nameplate, and identify the corresponding PA/+ and PC/- terminals. See Figure 1 on page 12.

To measure the DC bus capacitor voltage:

1. Remove all power from the drive. Use a properly rated voltage sensing device to confirm power is off. Also, be sure to remove all external control power that may be present such as on the control board and the option board terminals.
2. Open the disconnect between the input line and the drive. Lock the disconnect in the open position and install a “Do Not Turn On” sign. Open the circuit breaker disconnect located on the front of the drive. Be sure to remove all external control power that may be present, such as on the control board and the option board terminals.
3. Wait fifteen minutes for the DC bus capacitors to discharge.
4. Open the door of the drive.
5. Set the voltmeter to the 1000 Vdc scale. Measure the voltage between the PA/+ and PC/- terminals.
6. Verify that the DC bus voltage has discharged below 42 V before servicing the drive. If the DC bus capacitors will not discharge below 42 V, contact your local Schneider Electric representative. **Do not operate the drive.**
7. After servicing the drive, close and secure door.

Wire Routing and Interconnection

Wire Class

The Wire Class describes the compatibility of the field wiring terminal with the conductor material and insulation system. When used in conjunction with the required conductor current rating and the controller ambient temperature rating, the Wire Class forms the basis for selecting a conductor size that limits the temperature on the conductor insulation at the field wiring terminal to acceptable limits. Conductors with operating temperatures exceeding those given by the Wire Class can be used, but the conductor size must be selected based on the Wire Class limits.

Noise Class

The Noise Class categorizes the electromagnetic properties of the voltages and currents present. The six Noise Class categories determine proper wiring methods and physical segregation.

Quiet Wiring 1 (QW1)

High-susceptibility analog and digital control signals. Signals falling under the classification of QW1 include digital communication/network circuits, controller analog I/O and analog process signals.

Quiet Wiring 2 (QW2)

Medium-susceptibility analog and digital control signals. Signals falling under the classification of QW2 include 24 Vdc and 24 Vac control circuits.

Standard Wiring 1 (SW1)

Low-Susceptibility control or power circuits rated less than 600 Vac (250 Vdc) and less than 15 A (voltage and current spectra are generally contained within 0.05–9 kHz). Signals falling under the classification of SW1 include 120 Vac control circuits.

Standard Wiring 2 (SW2)

Power circuits rated greater than 15 A (voltage and current spectra are generally contained with 0.05–9 kHz). Signals falling under the classification of SW2 include line power to controllers.

Standard Wiring 3 (SW3)

Reserved.

Pulse Wiring 1 (PW1)

Control or power circuits whose voltage or current spectra significantly exceed 9 kHz. Signals falling under the classification of PW1 include motor and dynamic braking circuits fed from PWM (pulse width modulation) power converters.

Voltage Class

The Voltage Class groups the voltages present into recognized conductor insulation categories (30, 150, 300, and 600 V) for selection of conductor insulation voltage rating and physical segregation.

Wiring Methods

⚠ DANGER

HAZARD OF ELECTRIC SHOCK, EXPLOSION, OR ARC FLASH

- Route and secure all conductors to prevent damage to insulation when installing them under or near sharp edges.
- When possible, use jacketed conductors.

Failure to follow these instructions will result in death or serious injury.

Based on the Noise Class and Voltage Class of the conductors, apply the wiring methods in Table 8 to the drive.

Table 8: Wire Routing and Interconnection

Wiring Methods and Considerations	Noise Class of Conductors ¹				
	QW1	QW2	SW1	SW2	PW1
Conductor Grouping in Wireways and Conduits					
1. Bundle all conductors of 1- or 3-phase AC power circuits to minimize stray magnetic fields.			X	X	X
2. Bundle all conductors of a DC power circuit to minimize stray magnetic fields.			X	X	X
3. When parallel conductors must be run in separate wireways or conduit, bundle the conductors into groups to minimize stray magnetic fields.				X	X
4. Maintain conductor runs that are as short and direct as possible.	X	X	X	X	X
Separation of Circuits					
1. Do not run different Noise Class conductors in the same conduit.	X	X	X	X	X
2. Do not run different Voltage Class conductors in the same conduit unless all conductors are insulated for the maximum Voltage Class present.	X	X	X	X	X
3. Separate all conductors by Noise Class. Use the following circuit separation when conductors run parallel for more than 12 inches.					
• Metallic conduit: 3 in. from QW to SW or PW	X	X	X	X	X
• Metallic tray: 3 in. from SW to PW			X	X	X
• Metallic tray: 6 in. from QW to SW or PW	X	X	X	X	X
• Against continuous metal surface: 3 in. from SW to PW			X	X	X
• Against continuous metal surface: 6 in. from QW to SW or PW	X	X	X	X	X
• Metallic conduit housing QW: 12 in. to non-metallic conduit SW or PW	X	X	X	X	X
• Non-metallic conduit: 3 in. from SW to PW			X	X	X
• Non-metallic conduit: 23 in. from QW to SW or PW	X	X	X	X	X
4. All PW conductor groups must be individually separated using metallic conduit.					X
5. If QW and SW1 wiring must cross SW2 or PW1 wiring, cross the bundles at right angles.	X	X	X	X	X
Common Mode Noise Issues					
1. Provide adjacent signal returns using twisted pair cable.	X	X			
2. Galvanically isolate the signal and the associated signal return path when possible.	X	X			
Shielding					
1. Use metallic conduit for all power and control circuits external to the controller enclosure.	X	X	X	X	X
2. Use shields that are continuous and equipped with a drain wire.	X	X	X		
3. Do not group different Noise Class conductors within the same shield.	X	X	X	X	X
4. Minimize the non-shielded portion of the conductor at the end of the shielded cable.	X	X	X	X	X
5. When shielding AC or DC power conductors, group the conductors to minimize the magnetic field in the shield.			X	X	X
Grounding					
1. Ground shields only at the controller end.	X	X	X	X	X
2. Use a separate ground wire for each shield ground.	X	X	X	X	X
3. Provide a ground wire with all conductor groups, whether in tray or conduit.			X	X	X
4. When multiple grounds must be made to a shielded power cable, the shield must have the same short circuit withstand capability as the grounding conductor in the power cable.			X	X	X
5. Terminate all power grounds and power shield grounds to the controller grounding point or power converter chassis.			X	X	X
6. Terminate all signal shield grounds to the terminals provided.	X	X			
7. Always supply a separate equipment grounding conductor with the controller power feed. Do not depend on metallic conduit for the grounding connection.			X	X	X

¹ "X" indicates applicability to the specified Noise Class.

Component Locations

Figures 16 and 17 (page 45) show the component identification and terminal strip location on the S-Flex enclosed drives. Table 10 on page 47 lists the wire size and terminal torque requirements.

Figure 16: Typical Component Identification and Terminal Strip Location (1–30 hp @ 208/230 Vac and 1–60 hp @ 460 Vac with Line Reactor)

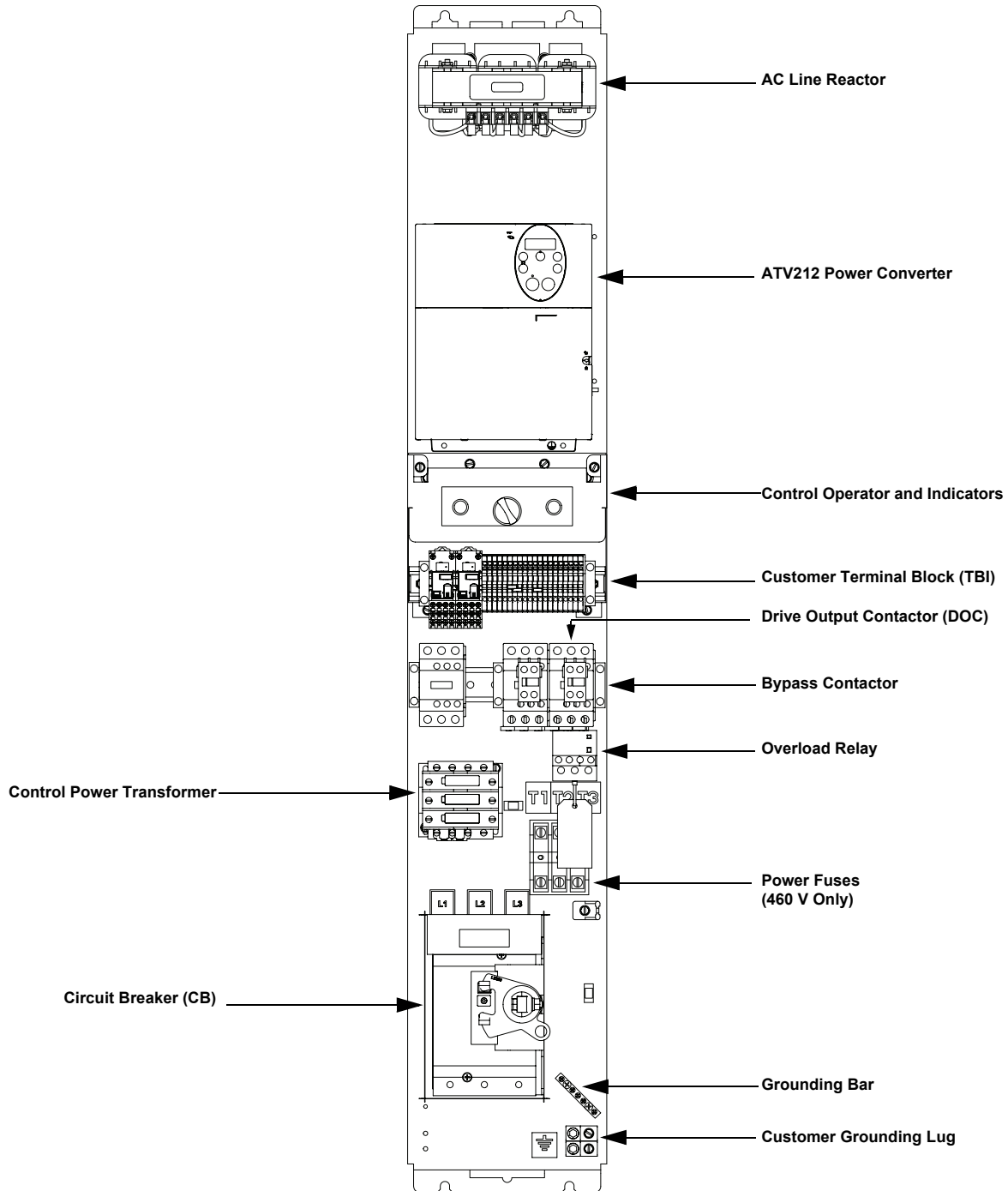
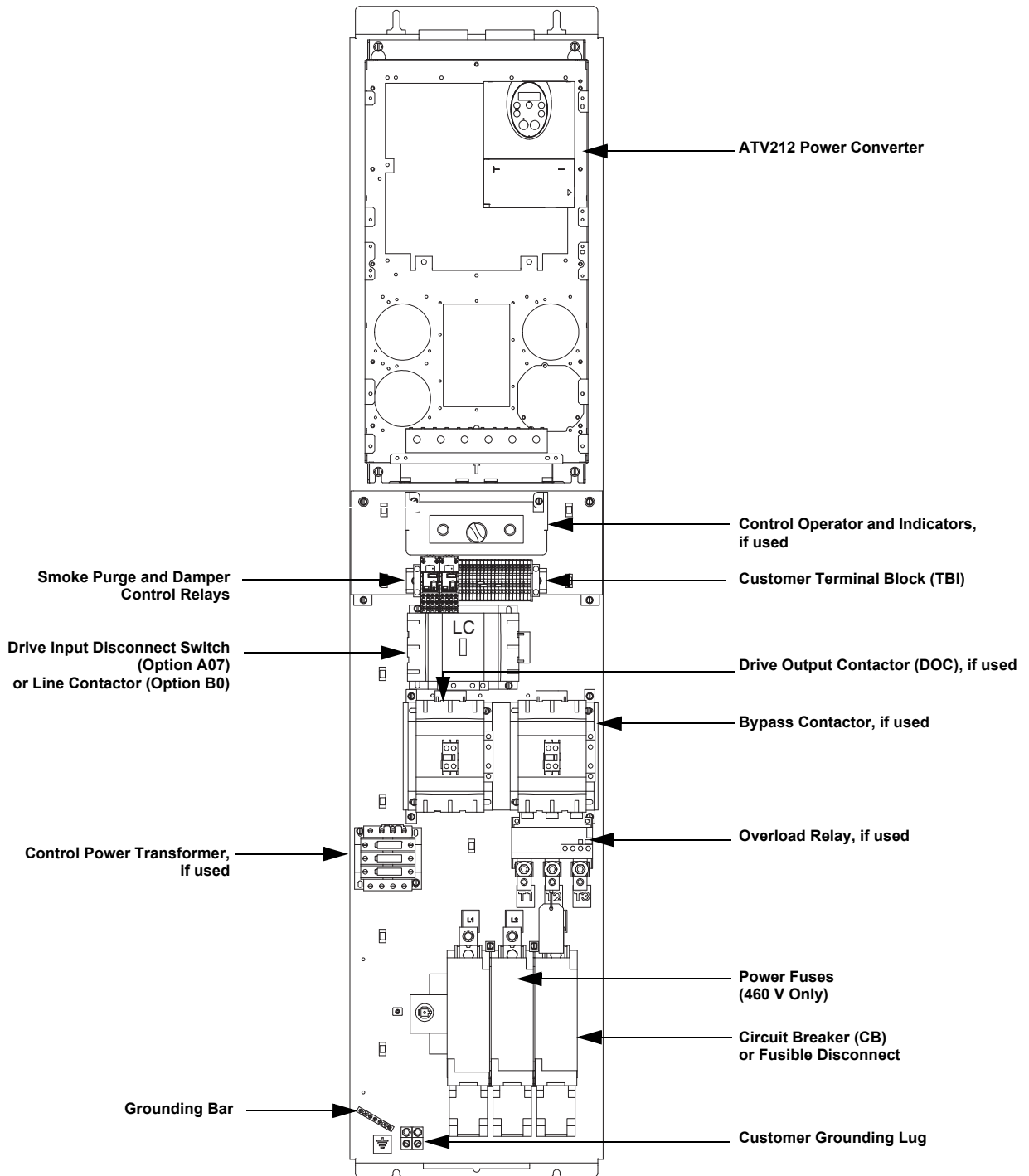

Figure 17: Typical Component Identification and Terminal Strip Location (40 hp @ 208/230 Vac and 75–100 hp @ 460 Vac)



Power Wiring

⚠ DANGER

HAZARD OF ELECTRIC SHOCK, EXPLOSION, OR ARC FLASH

- Apply appropriate personal protective equipment (PPE) and follow safe electrical work practices. See NFPA 70E or CSA Z462.
- Some terminals have voltage on them when the disconnect is open.
- Turn off all power supplying this equipment before working on or inside equipment.
- Always use a properly rated voltage sensing device to confirm that power is off.
- Replace covers before turning on power to equipment.
- Refer to “Before You Begin” starting on page 8 for important safety messages and precautions.

Failure to follow these instructions will result in death or serious injury.

⚠ CAUTION

IMPROPER WIRING

- Do not connect input power leads to the drive output terminals (T1, T2, T3 or U, V, W). This damages the controller and voids the warranty.
- Check the power connections before energizing the controller.

Failure to follow these instructions can result in injury or equipment damage.

⚠ CAUTION

HEAT AND FIRE DAMAGE

Follow the torque requirements specified on the S-Flex controller nameplate.

Failure to follow these instructions can result in injury or equipment damage.

Table 9: Power Terminal Characteristics

Terminal	Function	Characteristics ¹
GND	Ground (to grounding lug on panel)	—
L1, L2, L3	Three-phase power supply (to top of circuit breaker)	208 Vac +/- 10% (SFD212G2• units) 230 Vac +/- 10% (SFD212G3• units) 460 Vac +/- 10% (SFD212G4• units)
T1/U, T2/V, T3/W	Output connections to motor (from overload relay or power converter terminals)	208 Vac +/- 10% (SFD212G2• units) 230 Vac +/- 10% (SFD212G3• units) 460 Vac +/- 10% (SFD212G4• units)

¹ The “•” indicates that the catalog number can end in a “Y” (for an S-flex drive with full voltage bypass) or a “W” (for an S-Flex drive without bypass).

Table 10: Power Terminal Wire Range and Torque Requirements for FH Mag-Gard™ Circuit Breaker 1

SFD212	Circuit Breaker L1, L2, L3 (Line)		Overload Relay T1, T2, T3 (Load–Power Circuit Y)		Power Converter U, V, W (Load–Power Circuit W or Motor Grounding Point)		Distribution Block T1, T2, T3 (Load–Power Circuit W)		GND Bar		GND Lug	
	HP	AWG (mm ²)	lb-in (N•m)	AWG (mm ²)	lb-in (N•m)	AWG (mm ²)	lb-in (N•m)	AWG (mm ²)	lb-in (N•m)	AWG (mm ²)	lb-in (N•m)	AWG (mm ²)
1–3 @ 208 V 1–3 @ 230 V 1–7.5 @ 460 V	#14–4 (2.1–21.1)	30 (4.00)	#14–#8 (2.1–8.4)	15 (1.69)	#14–#10 (2.1–6)	11.5 (1.30)	—	—	#14–4 (2.1–21.1)	35 (3.95)	#14–1/0 (2.1–53.4)	100 (11.30)
5 @ 208 V 5 @ 230 V	#14–4 (2.1–21.1)	30 (4.00)	#14–#8 (2.1–8.4)	22.1 (2.50)	#12–#10 (3.3–6)	11.5 (1.30)	—	—	#14–4 (2.1–21.1)	35 (3.95)	#14–1/0 (2.1–53.4)	100 (11.30)
10–15 @ 460 V	#14–4 (2.1–21.1)	30 (4.00)	#14–#8 (2.1–8.4)	22.1 (2.50)	#12–#6 (3.3–13.3)	22 (2.70)	—	—	#14–4 (2.1–21.1)	35 (3.95)	#14–1/0 (2.1–53.4)	100 (11.30)
7.5–10 @ 208 V 7.5–10 @ 230 V	#14–1/0 (2.1–53.4)	80 (9.04)	#14–#8 (2.1–8.4)	22.1 (2.50)	#12–#6 (3.3–13.3)	22 (2.70)	—	—	#14–4 (2.1–21.1)	35 (3.95)	#14–1/0 (2.1–53.4)	100 (11.30)
20 @ 460 V	#14–1/0 (2.1–53.4)	80 (9.04)	#14–#8 (2.1–8.4)	22.1 (2.50)	#8–#3 (8.4–26.7)	40.0 (4.50)	—	—	#14–4 (2.1–21.1)	35 (3.95)	#14–1/0 (2.1–53.4)	100 (11.30)
15–25 @ 208 V 15–25 @ 230 V 25 @ 460 V	#14–1/0 (2.1–53.4)	80 (9.04)	#10–#2 (5.3–33.6)	100 (11.30)	#8–#3 (8.4–26.7)	40.0 (4.50)	—	—	#14–4 (2.1–21.1)	35 (3.95)	#14–1/0 (2.1–53.4)	100 (11.30)
30–60 @ 460	#14–1/0 (2.1–53.4)	80 (9.04)	#10–#2 (5.3–33.6)	100 (11.30)	#8–1/0 (8.4–53.4)	212 (24.0)	—	—	#14–4 (2.1–21.1)	35 (3.95)	#14–1/0 (2.1–53.4)	100 (11.30)

Table 11: Power Terminal Wire Range and Torque Requirements for the PowerPact™ H Frame Circuit Breaker¹

SFD212	Circuit Breaker L1, L2, L3 (Line)		Overload Relay T1, T2, T3 (Load–Power Circuit Y)		Power Converter U, V, W (Load–Power Circuit W or Motor Grounding Point)		Distribution Block T1, T2, T3 (Load–Power Circuit W)		GND Bar		GND Lug	
	HP	AWG (mm ²)	lb-in (N•m)	AWG (mm ²)	lb-in (N•m)	AWG (mm ²)	lb-in (N•m)	AWG (mm ²)	lb-in (N•m)	AWG (mm ²)	lb-in (N•m)	AWG (mm ²)
1–3 @ 208 V 1–3 @ 230 V 1–7.5 @ 460 V	#14–#10 (2.1–6)	50 (5.65)	#14–#8 (2.1–8.4)	15 (1.69)	#14–#10 (2.1–6)	11.5 (1.30)	—	—	#14–4 (2.1–21.1)	35 (3.95)	#14–1/0 (2.1–53.4)	100 (11.30)
5 @ 208 V 5 @ 230 V	#14–#10 (2.1–6)	50 (5.65)	#14–#8 (2.1–8.4)	22.1 (2.5)	#12–#10 (3.3–6)	11.5 (1.30)	—	—	#14–4 (2.1–21.1)	35 (3.95)	#14–1/0 (2.1–53.4)	100 (11.30)
7.5–10 @ 208 V 7.5–10 @ 230 V 10–15 @ 460 V	#8–#1 (8.4–42.4)	120 (13.56)	#14–#8 (2.1–8.4)	22.1 (2.5)	#12–#6 (3.3–13.3)	22 (2.70)	—	—	#14–4 (2.1–21.1)	35 (3.95)	#14–1/0 (2.1–53.4)	100 (11.30)
20 @ 460 V	#8–#1 (8.4–42.4)	120 (13.56)	#14–#8 (2.1–8.4)	22.1 (2.5)	#8–#3 (8.4–26.7)	40 (4.50)	—	—	#14–4 (2.1–21.1)	35 (3.95)	#14–1/0 (2.1–53.4)	100 (11.30)
15–25 @ 208 V 15–25 @ 230 V 25 @ 460 V	#8–#1 (8.4–42.4)	120 (13.56)	#10–#2 (5.3–33.6)	100 (11.3)	#8–#3 (8.4–26.7)	40 (4.50)	—	—	#14–4 (2.1–21.1)	35 (3.95)	#14–1/0 (2.1–53.4)	100 (11.30)
30 @ 208 V 30 @ 230 V	#8–1/0 (8.4–53.4)	120 (13.56)	#10–#1 (5.3–42.4)	100 (11.3)	#8–1/0 (8.4–53.4)	212 (24.0)	—	—	#14–4 (2.1–21.1)	35 (3.95)	#14–1/0 (2.1–53.4)	100 (11.30)
30–60 @ 460 V	#8–1/0 (8.4–53.4)	120 (13.56)	#10–#2 (5.3–33.6)	100 (11.3)	#8–1/0 (8.4–53.4)	212 (24.0)	—	—	#14–4 (2.1–21.1)	35 (3.95)	#14–1/0 (2.1–53.4)	100 (11.30)
40 @ 208 V	#8–3/0 (8.4–53.4)	120 (13.56)	#6–#3/0 (13.3–85)	160 (18.07)	#3–300 MCM (26.7–150)	212 (24.0)	#10–350 MCM (6–177)	250 (28.3)	#14–4 (2.1–21.1)	35 (3.95)	#14–1/0 (2.1–53.4)	100 (11.30)
40 @ 230 V	#8–3/0 (8.4–53.4)	120 (13.56)	#10–#1 (5.3–42.4)	100 (11.3)	#3–300 MCM (26.7–150)	212 (24.0)	#10–350 MCM (6–177)	250 (28.3)	#14–4 (2.1–21.1)	35 (3.95)	#14–1/0 (2.1–53.4)	100 (11.30)
75 @ 460 V	#6–3/0 (13.3–85)	200 (22.6)	#10–#1 (5.3–42.4)	100 (11.3)	#3–300 MCM (26.7–150)	363 (41.0)	#10–350 MCM (6–177)	250 (28.3)	#14–4 (2.1–21.1)	35 (3.95)	#14–1/0 (2.1–53.4)	100 (11.30)
100 @ 460 V	#6–3/0 (13.3–85)	200 (22.6)	#6–3/0 (13.3–85)	160 (18.07)	#3–300 MCM (26.7–150)	363 (41.0)	#10–350 MCM (6–177)	250 (28.3)	#14–4 (2.1–21.1)	35 (3.95)	#14–1/0 (2.1–53.4)	100 (11.30)

NOTE: For wire sizes in the range of 14–10 AWG, the required torque for the PowerPact H Frame circuit breaker is 50 lb-in. For wire sizes larger than 10 AWG, the required torque for the PowerPact H Frame circuit breaker is 120 lb-in.

¹ See Figures 21 and 22 on page 58 for circuit breaker identification.

Control Wiring

Connect the control wiring to the bottom portion of the terminal block TB1. See Figure 18.

Each terminal is rated for one wire, 24–16 AWG (0.25 –1.5 mm²). Torque the terminal screws to 5.3–7.1 lb-in (0.6–0.8 N•m). The customer terminals are designated on the wiring diagrams in this instruction bulletin. See Figure 25 on page 67.

Figure 18: Bypass Power Circuit Y

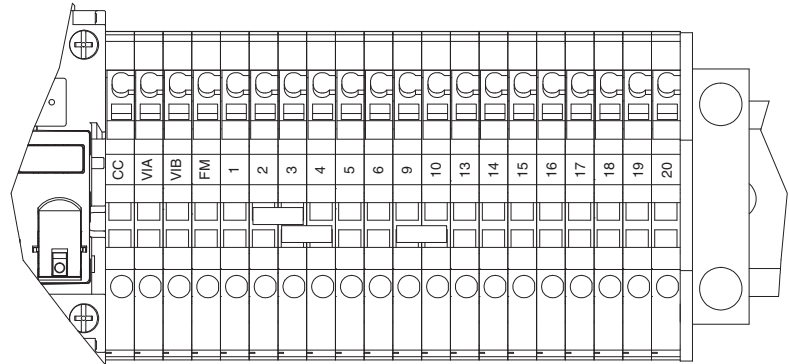

Table 12: TB1 Customer Terminal Connections

Function	Description	Customer Terminals (see Figure 18)	
0–10 Vdc Input	AFC Speed Reference	VIB	CC
4–20 mA or 0–10 Vdc Input	AFC Speed Reference ¹	VIA	CC
Analog Output Signal	Configurable	FM ¹	CC
Smoke Purge Relay Disable	Add Jumper	1	2
Freeze/Firestat	Remove Jumper / Add Interlock	2	3
Damper End Switch Enable	Remove Jumper	3	4
Auto Start Contact	AFC Mode Run Input	5	6
Smoke Purge Relay Disable	Remove Jumper	9	10
System Run Auxiliary Contact	Closes on Motor Running (AFC or BYP)	13	14
AFC Trip Auxiliary Contact	Closes on AFC Trip	15	16
Smoke Purge Relay Coil	120 Vac to Energize Coil	17	18
Open Damper Signal	Closes when Run Signal Provided	19	20

¹ Factory set for current control. To change the input VIA to voltage control, see *Altivar 212 Programming and Operation Guide*, S1A53838.

Figure 19: Non-Bypass Power Circuit W

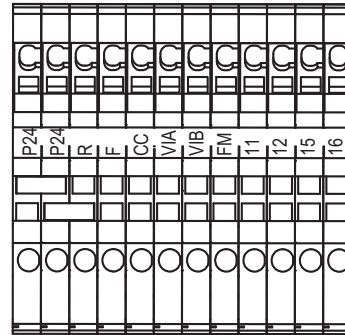

Table 13: TB1 Customer Terminal Connections for Controllers Without Bypass

Function	Description	Customer Terminals (see Figure 19)	
Auto Start Contact	AFC Mode Run Input	P24	F
Freeze/Firestat	Remove Jumper / Add Interlock	P24	R
0–10 Vdc Input	AFC Speed Reference	VIB	CC
4–20 mA or 0–10 Vdc Input	AFC Speed Reference ¹	VIA	CC
Analog Output Signal	Configurable	FM ¹	CC
AFC Run Auxiliary Contact	Closes with AFC Running Motor ¹	11	12
AFC Detected Fault Auxiliary Contact	Closes on AFC Detected Fault	15	16

¹ Factory set for current control.
 To change the input VIA to voltage control, see *Altivar 212 Programming and Operation Guide*, S1A53838.

Keypad Operation

Integrated Keypad

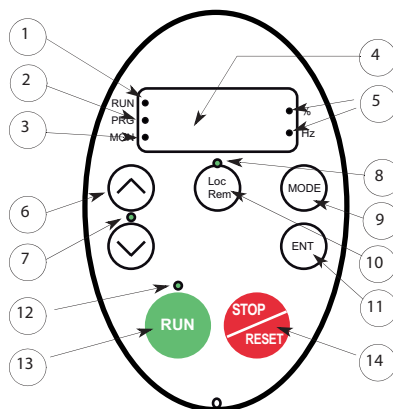

Table 14: Integrated Keypad Features¹

	LED/Key	Characteristics
1	Display RUN LED	Illuminates when a run command is applied to the drive. Flashes when there is a speed reference present with a Run command.
2	Display PRG LED	Illuminates when Programming mode is active. Flashes when programming parameters within menus (for example <i>R U H</i> , <i>R U F</i> , <i>G R U</i> , <i>I D</i> , or <i>C O N</i>).
3	Display MON LED	Illuminates when Monitoring mode is active. Flashes in trip history display mode.
4	Display unit	4 digits, 7 segments
5	Display unit LED	The % LED illuminates when a displayed numeric value is a percentage. The Hz LED illuminates when a displayed numeric value is in hertz.
6	UP/DOWN keys	Depending on the mode, you can use the arrows to: Navigate between the menus Change a value Change the speed reference when the UP/DOWN LED (7) is illuminated.
7	UP/DOWN LED	Illuminates when the navigation arrows are controlling the speed reference.
8	Loc/Rem LED	Illuminates when Local mode is selected.
9	MODE	Press to select the embedded keypad mode. <ul style="list-style-type: none"> • Run mode (default on power-up) • Programming mode • Monitoring mode Can also be used to go back to the previous menu.
10	Loc/Rem	Switches between Local and Remote modes.
11	ENT	Press to display a parameter's value or to save a changed value.
12	RUN LED	Illuminates when the Run key is enabled.
13	RUN	Pressing this key when the RUN LED is illuminated starts the drive.
14	STOP	Stop/reset key. In Local mode, pressing the STOP key causes the drive to stop based on the setting of parameter [Loc. mot stop mode] (<i>F 7 2 1</i>). In Remote mode, pressing the STOP key causes the drive to stop based on the setting of parameter [Ext. fault stop Mode] (<i>F 6 0 3</i>). The display will indicate a flashing "E". To reset the drive, cycle the power. If [HMI reset button] (<i>F 7 3 5</i>) is set to 0 (default setting), pressing the STOP key twice will reset all the resettable detected faults if the trip condition has been resolved.

¹ An optional graphic keypad is also available by selecting option D07. See page 51.

Graphic Keypad Option (D07)

The graphic keypad, with FLASH V1.1IE26 or higher, displays more detailed information than can be shown on the integrated keypad.

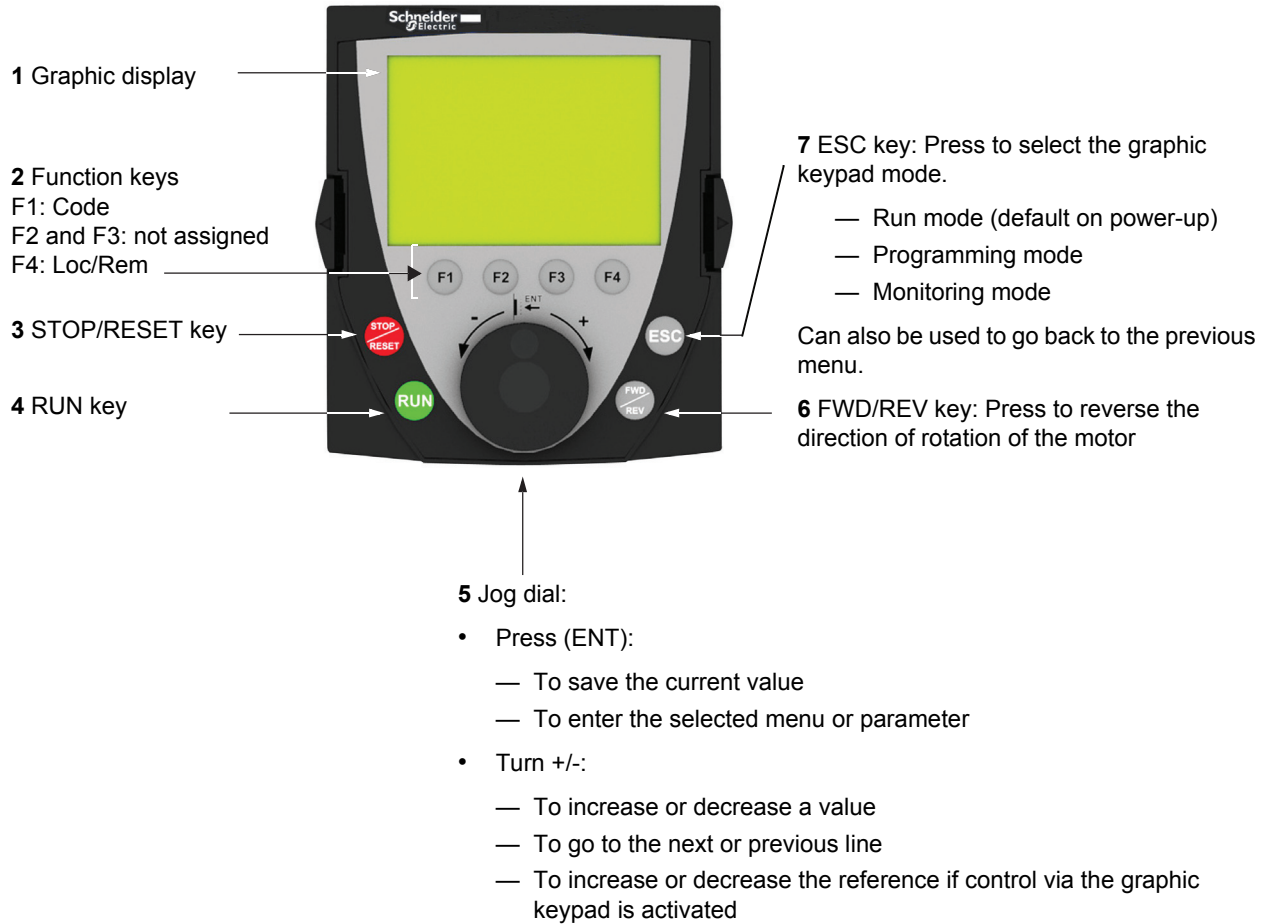

NOTE: Keys 3, 4, 5 and 6 can be used to control the drive directly, if control via the graphic keypad is activated.

Initial Start-up Procedure

⚠ DANGER

HAZARD OF ELECTRIC SHOCK, EXPLOSION, OR ARC FLASH

- Read and understand this manual before installing or operating the S-Flex drive. Installation, adjustment, repair, and maintenance must be performed by qualified personnel.
- The user is responsible for compliance with all international and national electrical code requirements with respect to grounding of all equipment.
- Many parts of this drive, including the printed circuit boards, operate at the line voltage. **DO NOT TOUCH.** Use only electrically insulated tools.
- Some terminals have voltage on them when the disconnect is open.
- **DO NOT** short across terminals PA/+ and PC/- or across the DC bus capacitors.
- Before servicing the drive:
 - Disconnect all power including external control power that may be present.
 - Place a “DO NOT TURN ON” label on all power disconnects.
 - Lock all power disconnects in the open position.
 - **WAIT 15 MINUTES** to allow the DC bus capacitors to discharge. Then follow the DC Bus Voltage Measurement Procedure on page 40 to verify that the DC voltage is less than 42 V. The drive LED is not an indicator of the absence of DC bus voltage.
- Install and close all covers and doors before applying power or starting and stopping the drive.

Failure to follow these instructions will result in death or serious injury.

⚠ DANGER

UNQUALIFIED PERSONNEL

- This equipment must be installed and serviced only by qualified personnel.
- Qualified personnel performing diagnostics or troubleshooting requiring electrical conductors to be energized must comply with NFPA 70 E - Standard for Electrical Safety Requirements for Employee Workplaces and OSHA Standards – 29 CFR Part 1910 Subpart S Electrical.

Failure to follow these instructions will result in death or serious injury.

⚠ DANGER

HAZARD OF ELECTRIC SHOCK, EXPLOSION, OR ARC FLASH

- Before applying power, properly ground the controller panel and close and secure the enclosure door.
- Certain adjustments and test procedures require that power be applied to this controller. Exercise extreme caution as hazardous voltages exist.
- The enclosure door must be closed and secured while turning on power or starting and stopping this controller. Always follow the practices and procedures from NFPA 70E, “Standard for Electrical Safety in the Workplace®.”

Failure to follow these instructions will result in death or serious injury.

The S-Flex drive has been configured for the installed options and tested at the factory. Minor adjustments to complete the field installation may be required based upon the application requirements. Using the door-mounted or remote-mounted graphic display terminal or the optional SoMove™ software, follow this start-up procedure step by step. In case of difficulty, refer to “Maintenance and Support” beginning on page 83.

Checking the Enclosure Components and Connections

With all incoming power removed, make the following equipment checks:

1. Verify that all equipment disconnects are open.
2. Set the AFC-Off-Bypass switch (if used) to Off.

⚠ WARNING

UNINTENDED CONFIGURATION CHANGES

- Changing the macro configurations or installing a new option card reconfigures the drive to factory settings.
- The controller configuration must be reinstalled.

Failure to follow these instructions can result in death or serious injury.

3. Wait 15 minutes, then perform the “DC Bus Voltage Measurement Procedure” described on page 40.
4. Open the enclosure door. To open the door, turn the handle assembly to the Off position.
5. Check the wiring of the input power ground and the motor ground.
6. Ensure that the motor conductors are wired to the T1, T2, and T3 terminals of the overload relay.

NOTE: When using the bypass circuit, ensure that the motor conductors are wired to the T1, T2, and T3 terminals of the overload relay. When using the power circuit without bypass, ensure that the motor conductors are wired to T1/U, T2/V, and T3/W of the controller, or T1, T2, and T3 of the distribution block.

Adjusting Bypass Motor Overload Protection

- If the controller includes a bypass option for running the motor across the line, set the Overload Relay dial (on the load side of the bypass contactor) to the full load ampere rating (FLA) listed on the nameplate of the connected motor. See Figure 20.

Figure 20: Overload Relay Dial

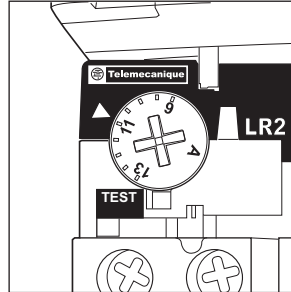

NOTE: The LR2D1516 overload relay is shown. Your dial setting range may be different. Refer to Table 15 on page 58 for range of adjustment.

- Using a voltmeter set at the 1000 Vac scale, verify that the incoming line voltage at the line side of the disconnecting means is within $\pm 10\%$ of the input voltage rating on the controller nameplate.
- When supplied with a Drive Input Disconnect Switch, confirm that the switch is in the On position.
- Close and secure the enclosure door. Close the equipment disconnect means. The Power On pilot light illuminates (if used for Bypass Power Circuit Y).

CAUTION

OVERHEATED MOTOR

- This drive does not provide direct thermal protection for the motor.
- Use of a thermal sensor in the motor may be required for protection at all speeds or load conditions.
- Consult the motor manufacturer for the thermal capability of the motor when it is operated above the desired speed range.

Failure to follow these instructions can result in injury or equipment damage.

- Adjust the full load current setting as follows:

Programming by 7-Segment LED

- Press the MODE key on the integrated display terminal until the PRG LED is illuminated and the display shows AUF. Press the ENT key once, then press the DOWN arrow key until tHr is displayed.
- Press the ENT key, then use the UP and DOWN arrow keys to adjust the setting to match the full load current listed on the motor nameplate.
- Press the ENT key to save the setting, and press the MODE key three times to return to the original menu.

Programming by Graphic Keypad

- Press the ESC key until the PROGRAMMING MENU is displayed, turn the Jog dial until QUICK MENU (AUF) is highlighted. Press the Jog dial once, then turn the Jog dial until MOTOR THERMAL PROT. (tHr) is highlighted.

- Press the Jog dial once to adjust the setting to match the full load current on the motor nameplate.
- Press the Jog dial once to save the setting. Press the ESC key to exit to the PROGRAMMING MENU.

NOTE: The settings listed in this procedure are suitable for most applications. If your application requires different operating characteristics, refer to the *Altivar 212 Programming and Operation Guide*, S1A53838, for more information.

⚠ WARNING

HAZARDOUS MOVING PARTS

Before starting the drive, ensure that personnel are clear of the motor and its connected load and that the motor and load are ready to run.

Failure to follow these instructions can result in death or serious injury.

Checking and Correcting Motor Rotation

12. Set the AFC-Off-Bypass selector switch (if used) to AFC. Check the direction of motor rotation. If correct, proceed to Step 17. If incorrect, turn the AFC-Off-Bypass selector switch back to Off or press STOP on the power converter control keypad.

⚠ DANGER

HAZARD OF ELECTRIC SHOCK, EXPLOSION, OR ARC FLASH

- Turn off all power supplying this equipment.
- Wait 15 minutes.
- Perform the “DC Bus Voltage Measurement Procedure” on page 40 before proceeding.

Failure to follow these instructions will result in death or serious injury.

13. Correct the direction of motor rotation by reversing any two motor leads connected to the controller output (see Step 6, page 53).
14. Close and secure the enclosure door. Close the equipment disconnect means. The Power On pilot light illuminates.
15. Set the AFC-Off-Bypass selector switch to AFC. Check the direction of motor rotation. If correct, this completes the controller mode, motor rotation check. For Non-Bypass Power Circuit W, skip to Step 20.

Checking and Correcting Motor Rotation in Bypass Mode

16. Set the AFC-Off-Bypass selector switch to Off.
17. Momentarily set the AFC-Off-Bypass selector switch to Bypass to check the direction of motor rotation, then return it immediately to the Off position. If the direction of motor rotation is correct, proceed to Step 20. If incorrect, stop the drive. **Remove all power!**

NOTE: If the controller circuit breaker trips during this test, a higher trip setting may be required. Refer to “Adjusting Mag-Gard or PowerPact Magnetic Trip Setting” on page 57.

⚠ DANGER

HAZARD OF ELECTRIC SHOCK, EXPLOSION, OR ARC FLASH

- Turn off all power supplying this equipment.
- Wait 15 minutes.
- Perform the “DC Bus Voltage Measurement Procedure” on page 40 before proceeding.

Failure to follow these instructions will result in death or serious injury.

18. Correct the direction of motor rotation by reversing any two incoming leads to the circuit breaker disconnect means marked L1, L2, or L3.
19. Momentarily set the AFC-Off-Bypass selector switch to Bypass to check the direction of motor rotation, then return it immediately to the Off position. If correct, this completes the bypass mode motor rotation check.

Checking the Graphic Terminal Settings

20. Adjust the High Speed (UL) Setting as follows:

Programming by 7-Segment LED

Check the High Speed (UL) setting (maximum motor speed). Press the MODE key until AUF is displayed. Using the UP and DOWN arrow keys, scroll to UL, then press the ENT key. Use the UP and DOWN arrow keys to adjust the maximum output frequency for the required application (factory default is 60 Hz), then press the ENT key. The controller UL setting is now complete.

Programming by Graphic Keypad

Check the High Speed (UL) setting (maximum motor speed.) Press the ESC key until PROGRAMMING MENU is displayed and turn the dial until QUICK MENU (AUF) is highlighted, then press the Jog dial. Turn the Jog dial until UPPER LIMIT FREQ (UL) is highlighted, then press the Jog dial. Turn the Jog dial to adjust the maximum output frequency for the required application (factory default is 60 Hz), then press the Jog dial once to save the setting.

Refer to the *Altivar 212 Programming and Operation Guide*, S1A53838.

21. Adjust the Low Speed (LL) Setting as follows:

Programming by 7-Segment LED

Check the Low Speed (LL) setting (minimum motor speed). Continuing from Step 20 above, using the UP and DOWN arrow keys, scroll to LL, then press the ENT key. Use the UP and DOWN arrows keys to adjust the minimum output frequency for the required application (preset value is 15 Hz; factory default is 0 Hz), then press the ENT key. The controller LL setting is now complete. Press the MODE key three times to return to the original menu.

Programming by Graphic Keypad

Check the Low Speed (LL) setting (minimum motor speed). Continuing from Step 20 above, turn the Jog dial until LOW LIMIT FREQUENCY (LL) is highlighted, then press the Jog dial. Turn the Jog dial to adjust the minimum output frequency for the required application (preset value is 15 Hz; factory default is 0 Hz), then press the Jog dial once to save the setting. The controller LL setting is now complete. Press the ESC to return to the MAIN MENU.

Refer to the *Altivar 212 Programming and Operation Guide*, S1A53838.

22. The application may require changing the setting of acceleration (ACC) and deceleration (dEC) times. The preset value is 60 seconds. If the power converter has been replaced or reset to the factory default, the value is model dependent. Refer to the *Altivar 212 Programming and Operation Guide*, S1A53838, for information about the settings.

Adjusting Mag-Gard or PowerPact Magnetic Trip Setting

The adjustable magnetic trip setting is factory-set at Lo for Mag-Gard Motor Circuit Protectors. For PowerPact Motor Circuit Protectors, the Full Load Amp (FLA) Setting is factory set to the lowest position and the Instantaneous Trip Setting (Im) is factory set to the Auto 1 position. These settings may have to be adjusted for proper motor start-up. For both Mag-Gard and PowerPact Motor Circuit Protectors, refer to the magnetic trip setpoint limits outlined in the applicable national standards. For PowerPact Motor Circuit Protectors, also refer to the *PowerPact Motor Circuit Protector Settings* instruction bulletin (48940-260-01) shipped with the equipment. Some units include thermal-magnetic circuit breakers which do not require any adjustment.

⚠ DANGER

HAZARD OF ELECTRIC SHOCK, EXPLOSION, OR ARC FLASH

- Apply appropriate personal protective equipment (PPE) and follow safe electrical work practices. See NFPA 70E or CSA Z462.
- This equipment must only be installed and serviced by qualified electrical personnel.
- Turn off all power supplying this equipment before working on or inside equipment.
- Always use a properly rated voltage sensing device to confirm power is off.
- Replace all devices, doors, and covers before turning on power to this equipment.

Failure to follow these instructions will result in death or serious injury.

Figure 21: FH Mag-Gard Circuit Breaker Trip Adjustment

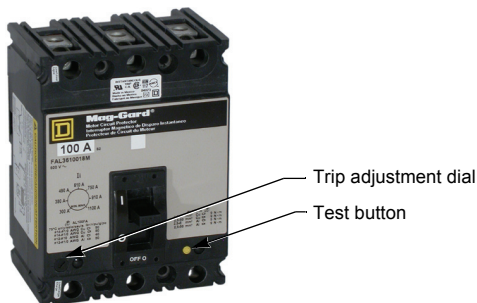

To access the Trip Adjustment dial on the FH Mag-Gard circuit breaker (if included):

1. Turn off all power supplying this equipment before working on or inside the equipment, and follow lockout/tagout procedures. Always use a properly rated voltage sensing device to confirm the power is off.
2. Place the unit handle in the Off position and open the door.

After obtaining the motor full load current from the motor nameplate, select an adjustable trip setpoint to test start the motor. Further adjustments may be required because of motor load characteristics. Refer to applicable national standards for permissible setpoints.

After adjusting the trip setting, reset the circuit breaker by moving the disconnect handle to the On position and then to the Off position.

Figure 22: PowerPact Circuit Breaker Trip Adjustment

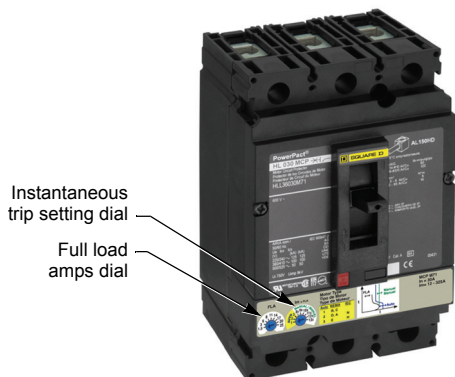

To access the Instantaneous Trip Setting (Im) and Full Load Amps (FLA) dials on the PowerPact circuit breaker (if included):

1. Turn off all power supplying this equipment before working on or inside the equipment, and follow lockout/tagout procedures. Always use a properly rated voltage sensing device to confirm the power is off.
2. Place the unit handle in the Off position and open the door.
3. To set the FLA and Im dials, refer to the PowerPact Motor Circuit Protector Settings instruction bulletin (48940-260-01) shipped with the equipment.

NOTE:

- These circuit breakers are suitable for motors with locked-rotor indicating code letters based on applicable national codes and standards. For other motors, consult your local Schneider Electric field sales representative.
- A fusible disconnect is provided with the 75 hp and 100 hp, 460 V drives instead of a circuit breaker.

Fusible Disconnect

Due to wire routing you may need to disconnect the motor power conductors to access the fuses. When replacing fuses, torque fuse bolts to 275 lb-in (31.1 N•m).

Overload Relay Adjustment

Always verify that the overload relay setting does not exceed the motor full load current or rated controller current found on the S-Flex nameplate, whichever is less.

Table 15 provides the range of adjustment provided for overload relays according to horsepower rating and voltage. Contact the factory if the overload relay range or adjustment does not meet the intended application.

Table 15: Overload Relay Adjustment Range (Amperes)

HP	208 V	230 V	460 V
1	4–6	4–6	1.6–2.5
2	5.5–8	5.5–8	2.5–4
3	9–13	7–10	4–6
5	12–18	12–18	7–10
7.5	23–32	16–24	9–13
10	23–32	23–32	12–18
15	37–50	37–50	16–24
20	48–65	48–65	23–32
25	63–80	63–80	30–40
30	80–104	80–104	30–40
40	90–150	95–120	48–65
50	—	—	63–80
60	—	—	63–80
75	—	—	95–120
100	—	—	90–150

Section 4—Operation

⚠ DANGER

HAZARD OF ELECTRIC SHOCK, EXPLOSION, OR ARC FLASH

Read and understand the precautions in “Before You Begin” starting on page 8 before performing the procedures in this section.

Failure to follow these instructions will result in death or serious injury.

⚠ DANGER

UNINTENDED EQUIPMENT OPERATION

Before operating the S-Flex enclosed drives:

- Read and understand instruction bulletins S1A53832 and S1A53838 before changing any parameters from the factory defaults. See page 7 for list of instruction bulletins and information for obtaining them.
- Refer to Table 16 on page 60 for parameter setting sequence.
- If the power converter is re-initialized using the total or partial factory setting function, the power converter must be reprogrammed to the values listed in Table 16 on page 60.
- If the power converter or the main control board of the power converter is replaced, the power converter must be reprogrammed according to the programming instructions in Table 16 on page 60.

Failure to follow these instructions can result in death, or serious injury.

Programming the Power Converter

The Altivar 212 power converters are factory configured as shown in Table 16. Be sure to configure the power converter’s motor full-load current as shown on the motor nameplate. For additional programming information, see the *Altivar 212 Programming and Operation Guide*, S1A53838, supplied with drive.

⚠ WARNING

LOSS OF CONTROL

Changes to factory set parameters must be completed in the sequence of appearance in Table 16 on page 60.

Failure to follow these instructions will result in death, serious injury, or equipment damage.

Changes to factory settings must be completed in the sequence of appearance in Table 16.

Table 16: Power Converter Factory Configuration (*change factory set parameters according to table sequence*)

Parameter	Name	Unit	Description	Factory Setting	Customer Setting
<i>EYP</i>	Parameter reset type	—	60 Hz	2	
<i>RU1</i>	Auto ramp adaptation	—	Disable auto ramp	0	
<i>ACC</i>	Acceleration time 1	seconds	Acceleration time	60	
<i>DEC</i>	Deceleration time 1	seconds	Deceleration time	60	
<i>UL</i>	High speed	Hz	High speed	60	
<i>LL</i>	Low speed	Hz	Low speed	15	
<i>ULU</i>	Motor rated voltage	V	230/208 V models	230/208	
			460 V models	460	
<i>PE</i>	Motor control mode	—	Variable torque	1	
<i>EHr</i>	Motor rated current overload	A	Overload setting	100% of the drives' output rating	
<i>RU4</i>	Macro programming See <i>Macro Programming</i> in the <i>Altivar 212 Programming and Operation Guide</i> , S1A53838.	—	Run permissive	1	
<i>F130</i>	RC/RYC – RY/RYA relay primary function, Terminals 11 and 12 See <i>Relay Output Function</i> in the <i>Altivar 212 Programming and Operation Guide</i> , S1A53838.	—	Drive running	14	
<i>F132</i>	FL relay function, Terminals 15 and 16 See <i>Relay Output Function</i> in the <i>Altivar 212 Programming and Operation Guide</i> , S1A53838.	—	Inversion of relay	10	
<i>F201</i>	VIA speed reference level	%	4 mA minimum	20	
<i>F605</i>	Output phase failure detection	—	Disabled	0	
<i>F692</i>	Analog output bias	%	4 mA minimum	20	

Additional Factory Programming Configuration for Options A06, B06, C06, and D06

Parameter	Name	Unit	Description	Factory Setting	Customer Setting
<i>FB29</i>	Protocol	—	BACnet (A06)	4	
			LonWorks® (B06)	1	
			Metasys® N2 (C06)	2	
			Apogee™ P1 (D06)	3	
<i>CND</i>	Remote mode start/stop control source	—	Serial Communication	2	
<i>FND</i>	Remote mode primary speed reference source	—	Serial Communication	4	

Adjustments to the Factory Programming Configuration to Allow Serial Communication Control Through the Modbus RJ-45 port

Parameter	Name	Unit	Description	Factory Setting	Customer Setting
<i>CND</i>	Remote mode start/stop control source	—	Serial Communication	2	
<i>FND</i>	Remote mode primary speed reference source	—	Serial Communication	4	
<i>FB29</i>	Protocol	—	Modbus	1	

Adjustments to the Factory Programming Configuration to Allow Monitoring Only Through Options A06, B06, C06, D06

Parameter	Name	Unit	Description	Factory Setting	Customer Setting
<i>CND</i>	Remote mode start/stop control source	—	Terminals	0	
<i>FND</i>	Remote mode primary speed reference source	—	VIB	2	
<i>F10B</i>	Always active logic function	—	Forced local	48	

Power Circuit Y with Full Voltage Bypass

For power circuit Y with full voltage bypass, the S-Flex enclosed drives operate either by the power controller or at full-speed, full-voltage bypass. You can run the motor in bypass mode in the unlikely event that the power converter becomes inoperative.

The S-Flex enclosed drives consist of:

- An IEC-rated drive output and bypass contactor with electrical interlock and Class 10 overload relay
- A 120 Vac control power transformer (CPT)
- A Square D™ brand circuit breaker disconnect or fusible disconnect with the ability to lock in the open position
- An AFC-Off-Bypass switch
- A power converter

Always verify that the overload relay is set to the motor full load current.

Power Circuit W Without Bypass

For power circuit W without bypass, the S-Flex enclosed drives operate by the power controller only. This power circuit consists of a circuit breaker disconnect with means for locking in the open position, power converter, and optional equipment as specified.

Operator Controls – General Arrangement and Operation

Operator controls are located on the front of the power converter and the control rail for Bypass Power Circuit Y. AFC-Off-Bypass switch and indicators are not supplied with Non-Bypass Power Circuit W.

The AFC-Off-Bypass switch allows selection of power converter operation of the motor (AFC position) or line power operation of the motor (Bypass position).

▲ DANGER

UNINTENDED EQUIPMENT OPERATION

Before turning on the drive or upon exiting the configuration menus, ensure that the inputs assigned to the Run command are in a state that will not cause the drive to run. Otherwise, the motor can start immediately.

Failure to follow these instructions will result in death, or serious injury.

AFC Operation

AFC operation allows control of the motor with the power converter. To set the S-Flex drive to AFC operation, close the controller disconnect switch located on the front of the drive and place the AFC-Off-Bypass switch (if used) in the AFC position.

The power converter can be operated either locally or remotely depending on the Loc/Rem key setting (integrated keypad) or F4 key setting (graphic keypad). When using the integrated keypad, if the green LED above the Loc/Rem key is illuminated, the power converter is operating in local mode. When the green LED is not illuminated, the power converter is operating in remote mode. When using the graphic keypad, LOCAL or REMOTE is displayed above the F4 key.

- In local mode, the keypad Run and Stop keys can be used to start and stop the drive. Speed can be adjusted by pressing the UP and DOWN arrows on the integrated keypad, or by turning the Jog dial on the graphic keypad. The speed displays as output frequency in hertz.

- In remote mode, a run command and the speed reference signals can be sent to the power converter using either the logic input terminals or a serial communication network.
 - **Control through the logic input terminals** is the default factory setting when no communication options are selected. Start/stop functionality is available through the user-supplied auto start contact between TB1–P24 and TB1–F. Adjustable speed reference signals are sent through the analog input terminals VIA or VIB. The speed displays as output frequency in hertz.

The RJ-45 Modbus port is configured for monitoring only as a factory default. See Table 16 on page 60 for Modbus control information.
 - **Control through serial communication** is the default factory setting when a communication option is selected. The power converter responds to the run command and speed reference signals over the serial communications network. See Table 16 on page 60 for information about monitoring only through serial communications.

The RJ-45 Modbus port is occupied when graphic keypad (D07) is selected.

Bypass Operation

Bypass operation allows control of the motor with line power. To set the S-Flex drive to bypass operation, close the controller disconnect switch located on the front of the drive and place the AFC-Off-Bypass switch in the Bypass position. This transfers motor operation to line power, full speed operation. Moving the selector switch to the Off position opens the bypass contactor and stops the motor.

Freeze/Firestat Interlocks (If Used)

Terminals TB1-2 and TB1-4 accept a user-supplied, normally-closed (N.C.), freeze/firestat interlock. Remove the factory-installed jumper from the terminals before installing the interlock. If the connection between terminals TB1-2 and TB1-4 is open, the drive output contactor and the drive bypass contactor will open and cause the motor to coast. This feature can be used in conjunction with freeze sensors or in a firestat control system in accordance with NFPA (National Fire Protection Association) and local codes.

Pilot Lights

Pilot lights visually indicate protective functions and circuit status. The LED ratings for the pilot lights is 120 Vac.

The functions of the two pilot lights are:

- **Power On (red):** illuminates when the drive disconnect is turned on. When pilot lights are not supplied, Power On is indicated by illumination the of power convertor display.
- **Bypass Run (green):** illuminates while the drive is operating in bypass mode.

Pilot Lights are not available with Non-Bypass Power Circuit W.

Auxiliary Drive Run Contact

Provides a normally-open (N.O.) contact between terminals TB1–11 and TB1–12 that closes when the motor is running in drive mode.

Not available with communications options.

Auxiliary Bypass Run Contact

Provides an N.O. contact between terminals TB1–13 and TB1–14 that closes when the bypass contactor is closed and the motor is running in bypass mode.

Auxiliary Detected Fault Contact

Provides an N.C. contact between TB1–15 and TB1–16. Upon successful converter start-up, the contact will open and remain open until the drive detects a fault or is powered down.

Damper Control

Available only for S-Flex drives with the integral full voltage bypass circuit. To enable damper control, remove the jumper between terminals 3 and 4, and make appropriate connections to terminals 3, 4, 5, 6, 19, and 20.

AFC Mode

In AFC mode, if the drive is powered and in remote mode of operation, before starting the motor a customer-supplied auto start command contact closure between terminals 5 and 6 is required. When the auto start signal is provided, a dry relay contact closure occurs between terminals 19 and 20 that can be used by the customer to energize a damper actuator motor to open louvers that are closed when the controller is off.

NOTE: The power for the damper motor must be supplied separately by the user.

When the damper reaches an Open position, the damper end switch must close to provide feedback to the drive. The drive will then run the motor. The drive will continue to run until the auto start signal is removed or the damper end switch is no longer engaged. When damper control is enabled, the fan motor will freewheel stop when the auto start signal, damper end switch or other installed interlocks are removed.

Bypass Mode

When the S-Flex drive is set to BYP mode, the signal to power open the damper louvers is immediately made. When the damper end switch feedback is made, the bypass contactor will close. The motor will accelerate and run at line frequency speed until the Bypass is turned to off, the damper end switch made signal is lost, or any other installed interlocks are removed.

Smoke Purge Function (Fireman's Override)

Provides a smoke purge function which is controlled by a user-supplied, 120 Vac signal between terminals TB1–17 and TB1–18. Supplying 120 Vac to TB1–17 and TB1–18 transfers the motor operation to line power (if not operating in this mode already). This feature can be used in powered, smoke extract systems designed in accordance with NFPA and local codes. The Smoke Purge Function is not available with Non-Bypass Power Circuit W.

To disable the smoke purge function, remove the jumper between terminals TB1–9 and TB1–10 and install the jumper on terminals TB1–1 and TB1–2.

In the event that the smoke purge function is also enabled, the conditions described in "Damper Control" are not active. The controller full voltage bypass will close immediately, accelerating to line frequency speed regardless of the damper end switch position. Any required interlocks to prohibit operation once smoke purge has been activated must be connected to terminals 9 and 10. This may include damper end switch, high static pressure switch, freeze/firestats or any other device which, when opened, disables the motor operation even during a smoke purge event. Control wiring can be used to wire these signals in series so that the interlocks are active in normal and purge modes of operation. See details on Smoke Purge Function (Fireman's Override) and Figure 23 (page 65) for information on wiring external signals to the S-Flex drive with Bypass.

Options

MOD A06 – BACnet	The equipment comes pre-programmed for interface with BACnet communication protocol.
MOD A07 – Drive Input Disconnect Switch	This option provides an input line power disconnect switch between the mains power disconnect and the power converter. The Drive Input Disconnect Switch will disconnect line power to the power converter. The motor can run in bypass mode in the unlikely event the power converter becomes inoperative.
MOD B06 – LonWorks	The equipment comes pre-programmed for interface with LonWorks communication protocol. A LonWorks serial communication card is installed VW3A21212.
MOD B07 – Line Contactor	This option provides an electrically interlocked line contactor between the mains power disconnect and the power converter. When the drive is in bypass mode, the line contactor disconnects line power from the power converter. NOTE: Options A07 Drive Input Disconnect and B07 Line Contactor are available only when full voltage bypass option (Y05) is selected. Options A07 and B07 are mutually exclusive.
MOD C06 – Metasys N2	The equipment comes pre-programmed for interface with Metasys N2 communication protocol.
MOD D06 – Apogee P1	The equipment comes pre-programmed for interface with Apogee P1 communication protocol.
Mod D07 – Remote Graphic Keypad	This option provides a full-text door mounted graphic keypad with eight language options. With the graphic keypad, it is possible to display more detailed information than can be shown on the integrated keypad.
MOD N06 – ModBus	The drive provides factory standard ModBus communications.
MOD S07 – Seismic Qualified	This option supplies a certification label indicating that the enclosure is qualified with seismic rating AC156 acceptance criteria test protocol with an importance factor of 1.5. Refer to <i>Seismic Qualification Mounting Criteria on page 33</i> .
MOD X07 – Line Reactor	This option provides an AC line reactor, mounted and wired in series with the power converter. The line reactor supplies some additional inductance to limit the impact of mains transients which may occur in electrical distribution systems.

Figure 23: Full Voltage Bypass Package, Power Circuit Y

- NOTES:
- ⚠ REMOVE JUMPER 9-10 AND ADD JUMPER 1-2 TO DISABLE SMOKE FLUSH
 - ⚠ FREEZE/HEATSTAT INTERLOCKS. REMOVE JUMPER
 - ⚠ SEE PROGRAMMING AND OPERATION GUIDE, 30072-451-63
 - ⚠ TO CHANGE VIA TO A VOLTAGE AMONG UNIT, MOVE CONDENSABLE SWITCH TO THE "V" POSITION
 - ⚠ MODBUS VIA RS485 CONNECTION WIRING TO ALL DRIVES
 - ⚠ FUSES REQUIRED ON 460V MODELS ONLY; CONVERTER ENDING IN „JM“
 - ⚠ VARIABLE BASED ON THE FOLLOWING:
 - 1. REDUCES FLU
 - 2. REDUCES FLU
 - 3. REDUCES FLU
 - 4. REDUCES FLU
 - ⚠ FROM WHEN MODS ARE USED, 0.75% OF NAME PLATE KW IS REQUIRED FOR CONTROL. F BULLETIN 30072-451-83
 - ⚠ NOT AVAILABLE WHEN OPTION BOB SELECTED.
 - ⚠ DRIVE MUST DISCONNECT SWITCH OPTION (M00 A07) AND LINE CONNECTOR OPTION (M00 B07) UNLESS OTHERWISE INDICATED

- ⚠ DRIVE OPTIM. DISCONNECT SWITCH INCLUDED ONLY WHEN
- ⚠ LINE CONNECTOR INCLUDED ONLY WHEN M00 B07 SELECTED
- ⚠ FUSIBLE DISCONNECT SWITCH USED IN PLACE OF CIRCUIT BREAKER AND FUSE BLOCKS IN 75HP AND 100HP 460 VOLT UNITS REMOVE KEYPAD AVAILABLE WITH AV212 DRIVE ONLY, WHEN OPTION 007 IS SELECTED.
- ⚠ REMOVE JUMPER 3-4 TO DISABLE DRG DAMPER CONTROL
- ⚠ LINE REACTOR INCLUDED ONLY WHEN M00 X07 IS SELECTED

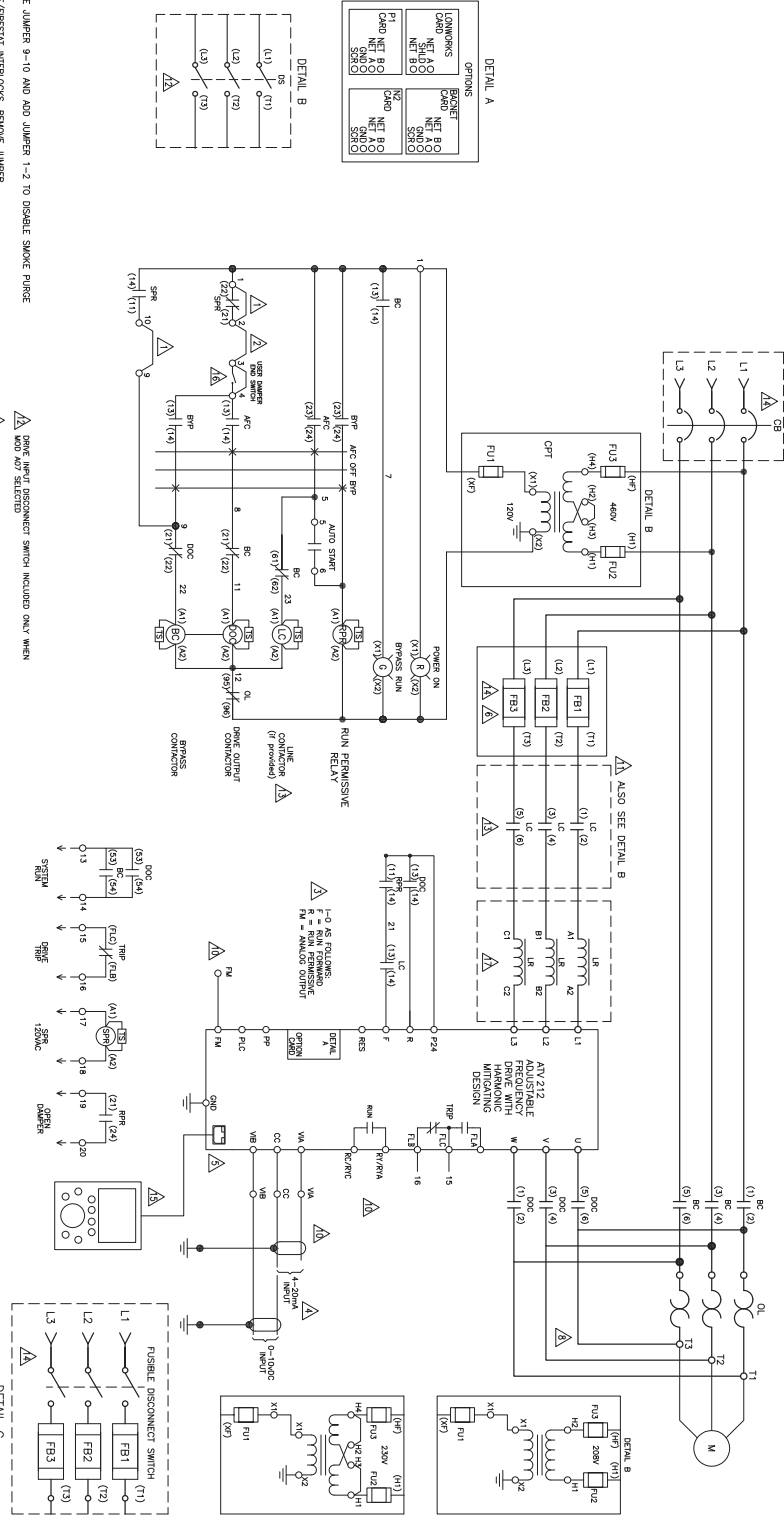

Figure 24: Power Circuit Y Full Voltage Bypass Package, 208 V and 230 V

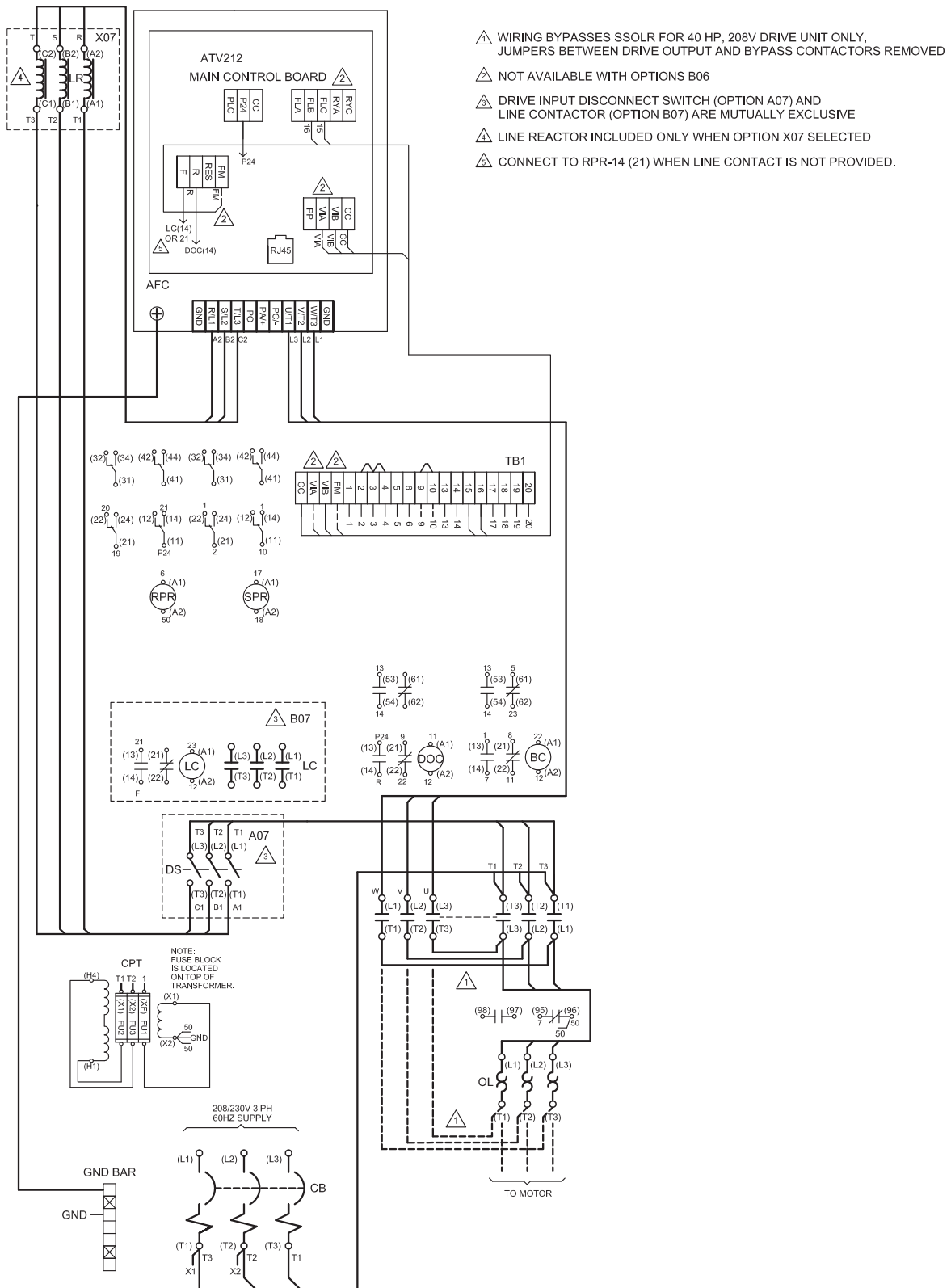

Figure 25: Power Circuit Y Full Voltage Bypass Package, 460 V

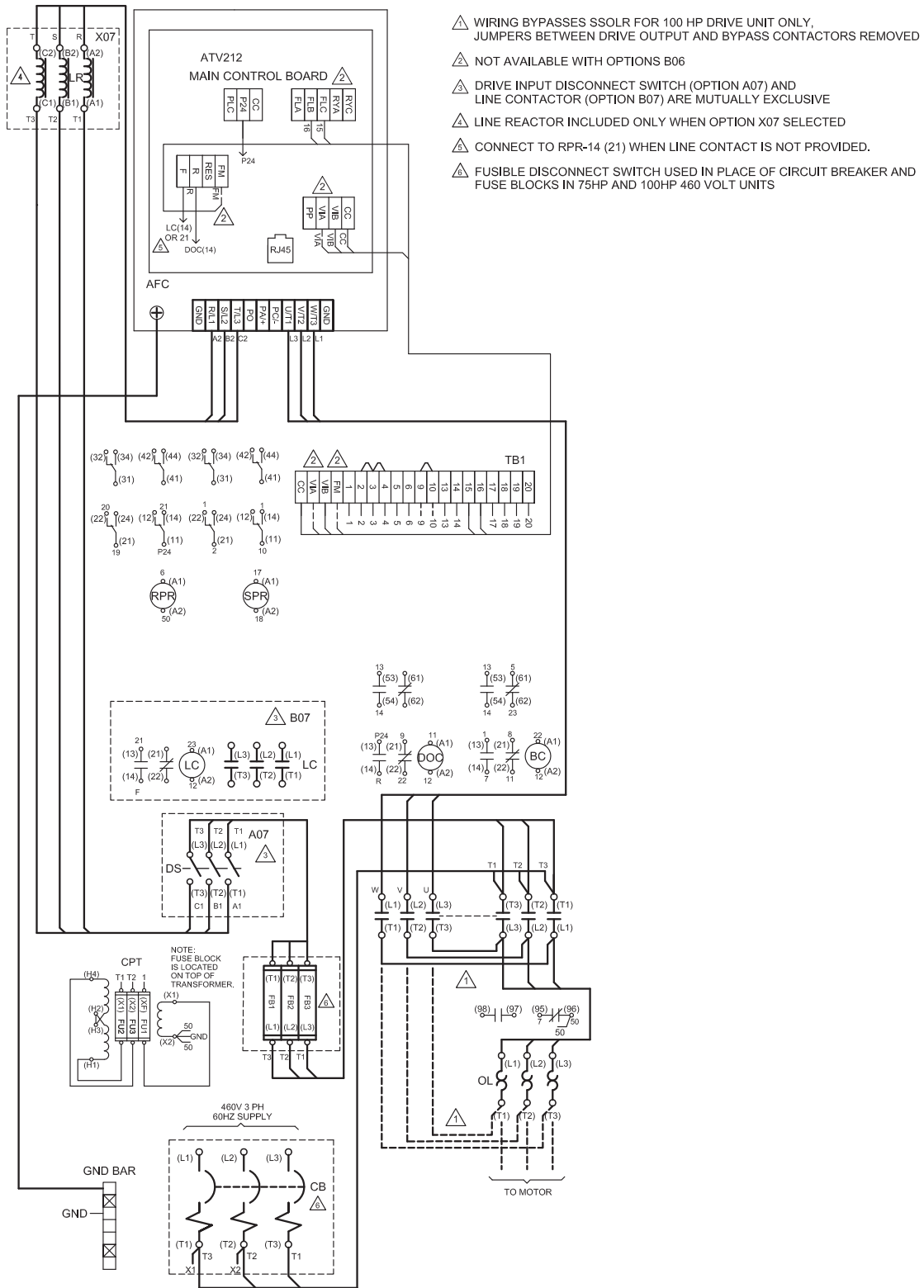

Figure 26: Non-Bypass Power Circuit W, 208/230 V and 460 V

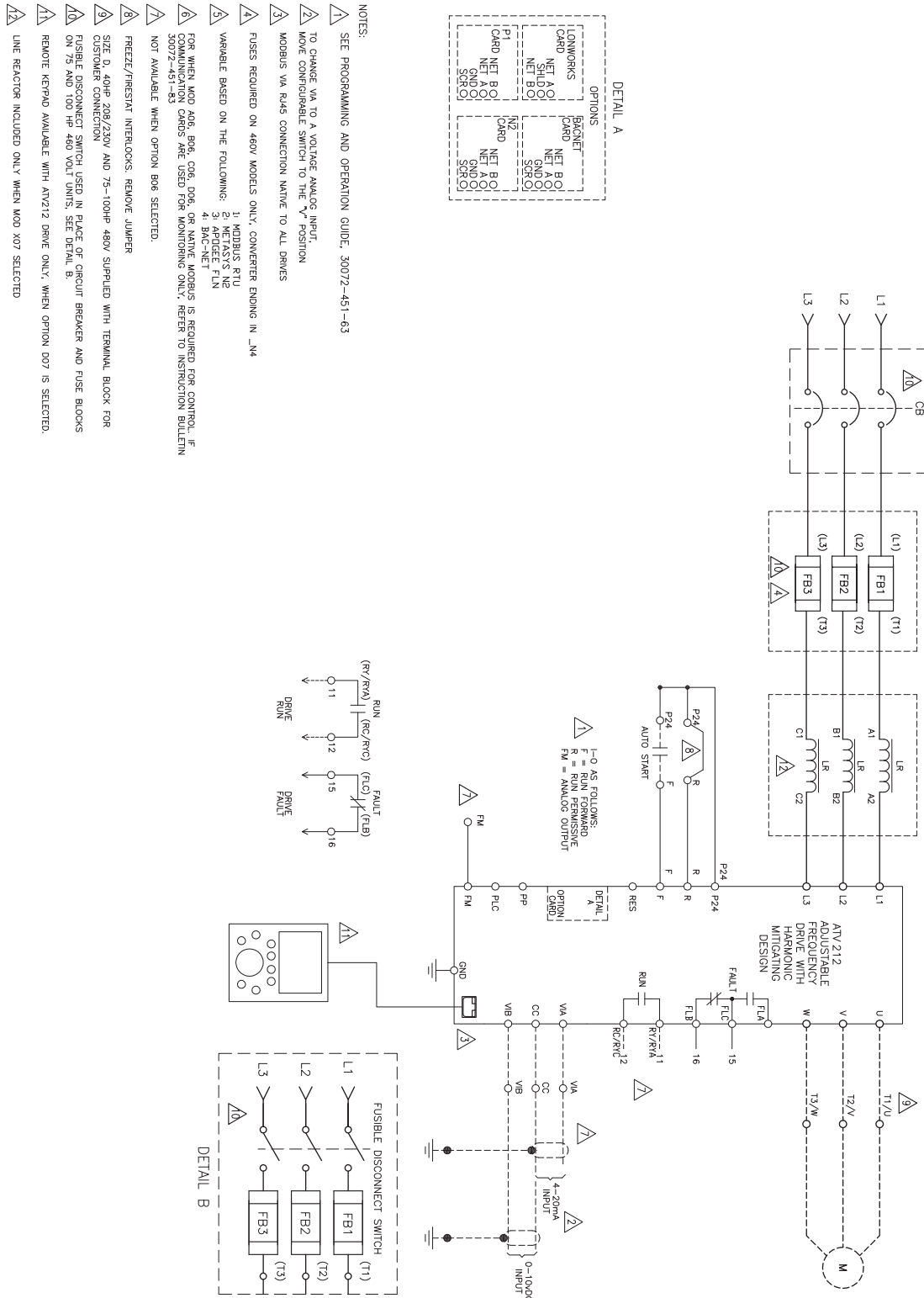

Figure 27: Power Circuit W Bypass Package, 208 V and 230 V

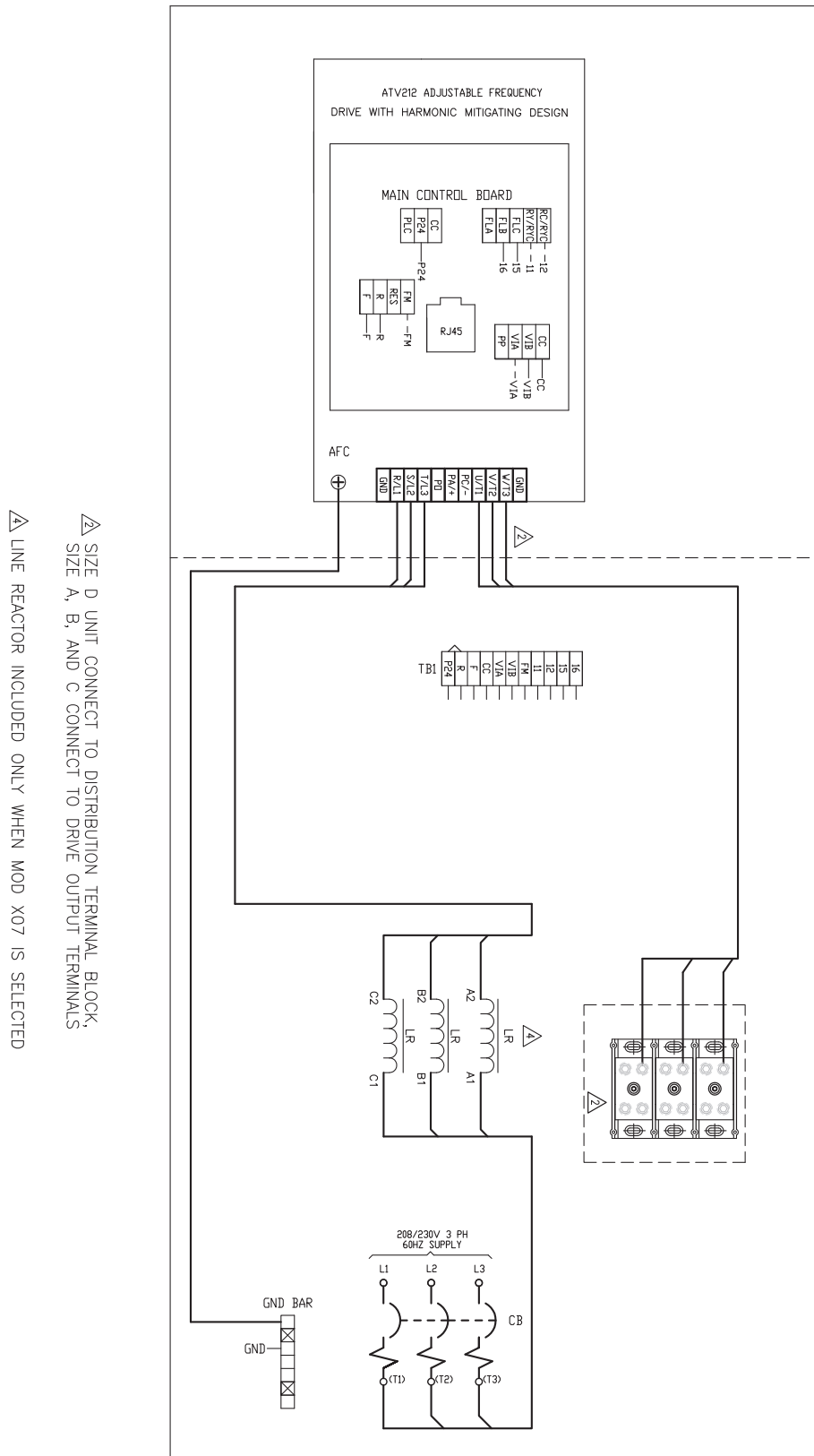
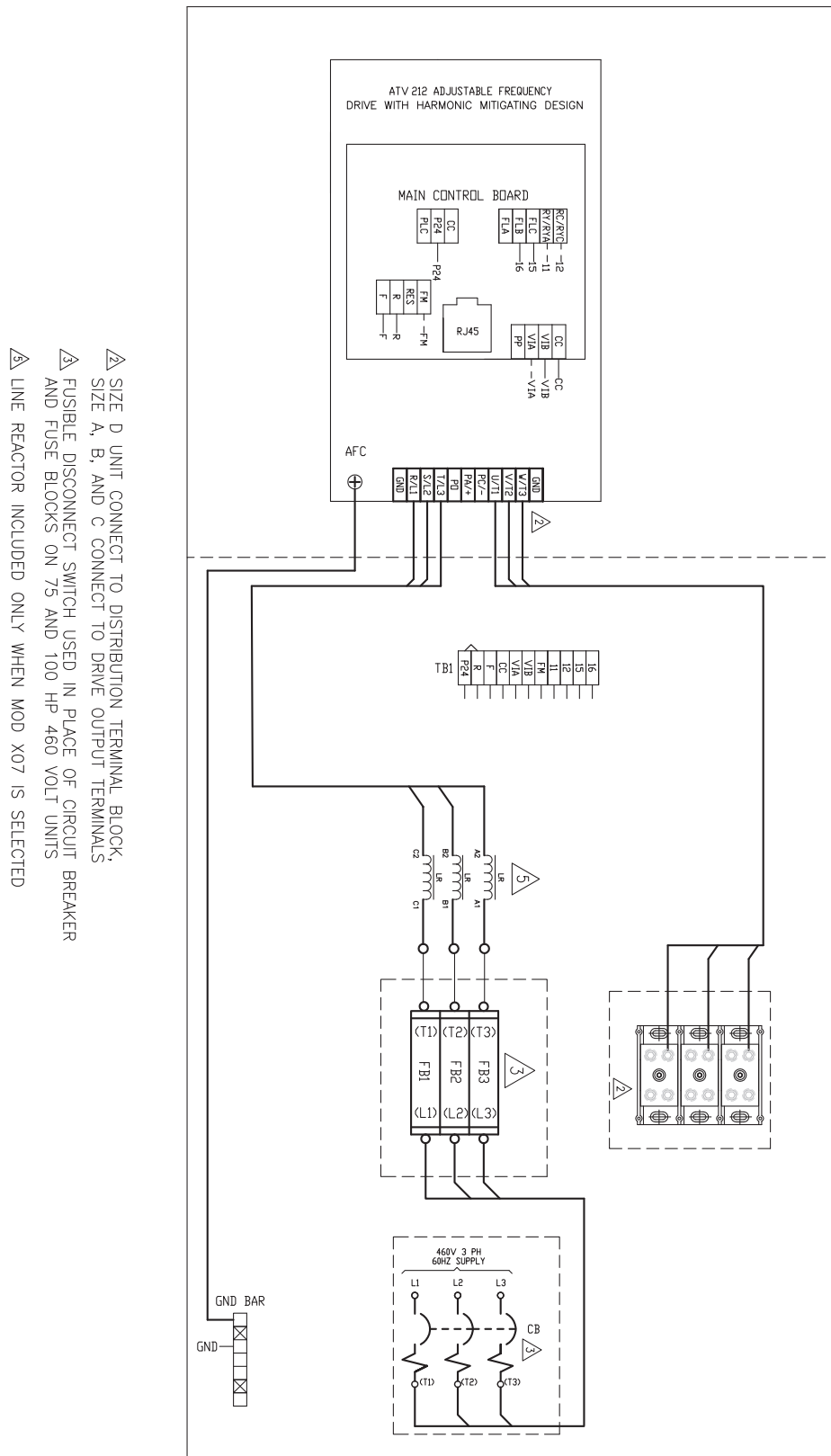

Figure 28: Power Circuit W Non-Bypass Package, 460 V



- ⚠ SIZE D UNIT CONNECT TO DISTRIBUTION TERMINAL BLOCK, SIZE A, B, AND C CONNECT TO DRIVE OUTPUT TERMINALS
- ⚠ FUSIBLE DISCONNECT SWITCH USED IN PLACE OF CIRCUIT BREAKER AND FUSE BLOCKS ON 75 AND 100 HP 460 VOLT UNITS
- ⚠ LINE REACTOR INCLUDED ONLY WHEN MOD X07 IS SELECTED

Section 5—Proportional–Integral–Derivative Control

DANGER

HAZARD OF ELECTRICAL SHOCK, EXPLOSION, OR ARC FLASH

- Read and understand this manual before installing or operating the S-Flex drive. Installation, adjustment, repair, and maintenance must be performed by qualified personnel.
- The user is responsible for compliance with all international and national electrical code requirements with respect to grounding of all equipment.
- Many parts of this drive, including the printed circuit boards, operate at the line voltage. **DO NOT TOUCH.** Use only electrically insulated tools.
- **DO NOT** touch unshielded components or terminal strip screw connections with voltage present.
- **DO NOT** short across terminals PA/+ and PC/- or across the DC bus capacitors.
- Before servicing the drive:
 - Disconnect all power.
 - Place a “DO NOT TURN ON” label on all power disconnects.
 - Lock all power disconnects in the open position.
 - Disconnect all power, including external control power that may be present, before servicing the drive. **WAIT 15 MINUTES** to allow the DC bus capacitors to discharge. Then follow the “DC Bus Voltage Measurement Procedure” to verify that the DC voltage is less than 42 V. The drive LED is not an indicator of the absence of DC bus voltage.
- Install and close all covers before applying power or starting and stopping the drive.

Failure to follow these instructions will result in death or serious injury.

DANGER

UNINTENDED EQUIPMENT OPERATION

- Test and ensure that any changes made to the parameter settings do not present any danger to personnel and equipment during the drive operation.
- Each control scheme must be individually and thoroughly tested for proper operation before being placed into service.

Failure to follow these instructions will result in death or serious injury.

Introduction

This section provides programming instructions for using Proportional-Integral-Derivative (PID) control on the S-Flex adjustable speed drive.

PID control provides a method for controlling a process variable using a closed loop feedback system. The error between the desired setpoint and feedback process variable provides continuous corrective action to control the process output. From an application standpoint, the drive output adjusts the speed of the motor to reduce the error to zero. Closed loop control eliminates the cycling normally associated with open loop on-off control methods. PID control aims to regulate the process consistently under changing conditions at a maximum rate with minimum waste and minimum cost of operation.

Process variables such as temperature, pressure, and level can be monitored by the drive as a current or voltage analog feedback signal. The PID regulator calculates the error between the setpoint and feedback for a closed loop, then applies an appropriate frequency reference to adjust the motor speed.

There are three control functions:

1. Proportional (P): The Proportional function determines the responsiveness of control or how quickly the output reacts to the error.
2. Integral (I): The Integral function determines the reaction based on the sum of recent errors and its absence may prevent the system from reaching its target value.
3. Derivative (D): The Derivative function determines the reaction to the rate at which the error has been changing and is very sensitive to measurement noise.

The weighted sum of P, I, and D functions is used to correct the process variable.

By tuning these three functions, the system performance including responsiveness (time to correct the error), overshoot (overage from the reference setpoint) and oscillations (cycling between the highest and lowest point until signal stabilization) can be controlled.

Figure 29: PID Control Concept

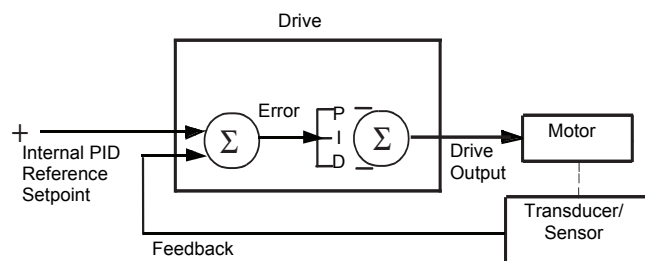
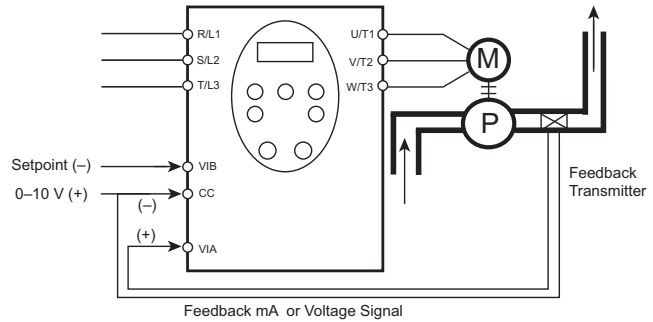

Figure 30: PID Setup for Drive



Scaling of PID Parameters

Scaling of PID parameters is required to suit a customer's application or range of the sensor input device providing the feedback signal (or both). Some examples of PID parameters and their ranges are pressure (0 to 20 psi), flow (0 to 500 gpm), and temperature (-100 °F to 300 °F).

SPEED REFERENCE LEVEL 1 and 2 parameters must be entered as a percentage of the analog input range (VIA or VIB) used as the feedback input signal. The OUTPUT FREQUENCY LEVEL 1 and 2 parameters are entered in Hz and set as a function of the speed reference (see Figure 31).

Figure 31: Examples of Terminal Setting

Example of VIB Terminal Setting

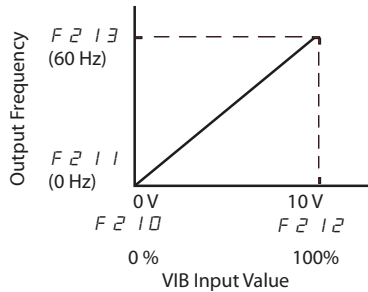

Example of VIA Terminal Setting (voltage input)

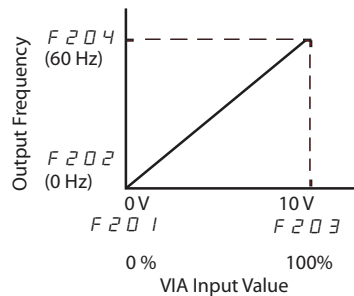

Example of VIA Terminal Setting (current input)

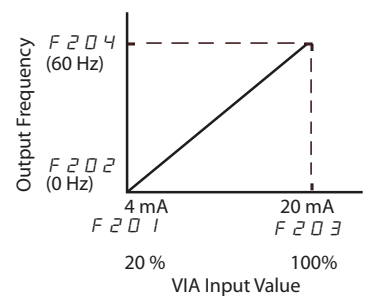

SPEED REFERENCE LEVEL parameter:

For a 4–6 V signal, set Speed Reference Level 1 to 40 and Speed Reference Level 2 to 60. Figure 31 illustrates scaling for a voltage signal of 0-10 V and a current signal of 4–20 mA.

OUTPUT FREQUENCY LEVEL parameter:

For an Output Frequency of 0–60 Hz, set Output Frequency Level 1 to 0 and Output Frequency Level 2 to 60.

PID Tuning

Tuning of the P, I, and D control functions is required to optimize the process performance based on application needs. There are several methods for tuning including manual, Ziegler-Nichols, and by using several software tools available in the market. The PID proportional gain (F362), Integral gain (F363) and derivative gain (F366) parameters can be adjusted to allow the PID regulator to be tuned for a specific application.

NOTE: Follow the instructions in *Drive Configuration via Integrated or Graphic Keypad* on page 76 to set-up the P, I, and D control functions and access the parameters for gains adjustment.

In many cases the factory settings for these parameters will be sufficient. However, if necessary, adjustments should be gradual and independent. If the system is unstable with the factory settings or the PID reference (setpoint) is not achieved, use the manual method described below:

- Set the integral gain (F363) to minimum.
- Leave the derivative gain (F366) at 0.
- Vary the load or PID reference setpoint a number of times and observe the PID regulator response.
- Set the proportional gain (F362) in order to obtain the best compromise between response time and stability.
- Once stable, if the steady state response varies from the preset value (setpoint), gradually increase the integral gain (F363), reduce the proportional gain (F362) in the event of instability (pump applications), and find a compromise between response time and precision.
- Typically, the derivative gain (F366) is not required, but may permit the reduction of overshoot and the improvement of response time. This can make it more difficult to obtain a compromise in terms of stability since this depends on 3 gains. If F366 is adjusted then the F362 and F363 may require re-adjustment.

Figure 32 on page 75 illustrates the system performance with adjustments in P, I, and D gains.

Figure 32: System Performance With Adjustments in P, I, and D Gains

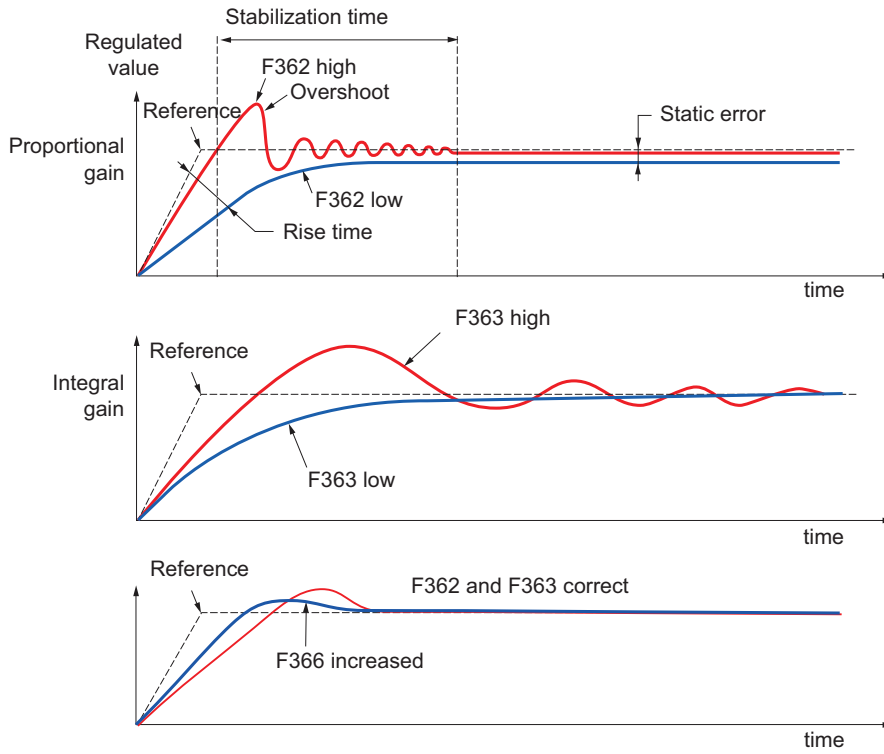

The oscillation frequency depends on the system's physical parameters and natural response.

Parameter	Rise time	Overshoot	Stabilization time	Static error
F362 ↗	↘↘	↗	=	↘
F363 ↗	↘	↗↗	↗	↘↘
F366 ↗	=	↘	↘	=

Setting PID Control

The procedure for setting PID control for analog inputs with 0–10 Vdc or 4–20 mA signal is described in this section.

For SFD21, PID control with 4–20 mA current feedback is only possible on drives without A06, B06, C06, D06 communication options selected.

For SFD212, PID control with 4–20 mA current feedback is only possible on drives without B06 communication options selected.

Ensure that the factory settings for the enclosed drive and motor parameters are set. For more information, refer to the *Altivar 212 Programming and Operation Guide*, S1A53838.

Drive Configuration via Integrated or Graphic Keypad

With the AFC-OFF-BYP selector switch in the Off position and prior to applying a run command to the drive, use the keypad to do the following:

Programming by Integrated Keypad:

1. Press the MODE key until AUF displays; then press ENT.
2. Scroll using the UP and DOWN arrow keys until FMOd displays; then press ENT.
3. Use the UP and DOWN arrow keys to adjust the desired control source.
Procedure is continued on page 77.

Programming by Graphic Keypad:

1. Press the ESC key to display the PROGRAMMING MENU and turn the Jog dial until FREQUENCY MODE SEL. (FMOd) is highlighted; then press the Jog dial.
2. Turn the Jog dial to adjust the desired control source, then press the Jog dial when the desired control source is highlighted.
Procedure is continued on page 77.

Table 17: Parameters

Parameter	Name	Setting
FMOd	Remote mode primary speed reference source (VIA)	1
	Remote mode primary speed reference source (VIB)	2
	Panel input setting Internal preset speed setting	3
	Remote mode primary speed reference source (Serial Comm.)	4

NOTE: VIA accepts a 0–10 Vdc voltage signal or a 4–20 mA current signal, VIB accepts a 0–10 Vdc voltage input signal. Refer to the *Altivar 212 Installation Guide*, S1A53832, for instructions on accessing SW3.

When operating with internal setpoint, the adjusted range is taken as a percentage value reference and not an actual speed value and may only be set between the lower speed limit (LL) and upper speed limit (UL). For example, if the intended reference output frequency is 30 Hz and UL is set for 60 Hz, the drive requires a reference signal corresponding to 50%. If LL is set to 30 Hz, the setpoint cannot be set below 50% using this method. Additional signal manipulation may be required to convert the fundamental output frequency to rotational speed, pressure, or flow.

Programming by Integrated Keypad:
Continued from Step 3 on page 76.

4. Press the ENT key to save the selection and to exit the FMOd parameter.
5. Use the UP and DOWN arrow keys until F--- (extended parameters) displays; then press the ENT key.
6. Use the UP and DOWN arrows to select the appropriate parameter and press ENT to modify the parameter.

Programming by Graphic Keypad:
Continued from Step 2 on page 76.

3. Turn the Jog dial until EXTENDED MENU (F---) is displayed; then press the Jog dial.
4. Turn the Jog dial to select the appropriate parameter and press the Jog dial to confirm the parameter setting.

NOTE: Press the ENT key after modifying each parameter value to save and exit the parameter value selection menu and return to the F--- menu.

Control Loop Configuration

To enable PID control, configure the analog feedback signal to VIA or VIB as required based on the type of transducer feedback signal used.

If VIB is used as the speed reference, then enable VIA to be used as the feedback signal. Use the UP and DOWN arrow keys to adjust the following parameter using the rules in Table 18.

Table 18: Parameters

Parameter	Name	Setting	Adjustment Range	Description
F360	PID Control Enable VIA (0–10 Vdc or 4–20 mA dc)	1	—	—
	PID Control Enable VIB (0–10 Vdc)	2	—	—
F362	PID Proportional Gain	—	0.01 to 100.0	Parameter F362 adjusts the proportional gain applied during PID control. The speed change applied to the motor is a correctional value proportional to the product of this parameter's setting and the process error.
F363	PID Integral Gain	—	0.01 to 100.0	Parameter F363 adjusts the integral gain applied during PID control. Any residual process errors that remain after correction by the proportional gain are cleared to zero over time by the integral gain function.
F366	PID Derivative Gain	—	0.00 to 2.55	Parameter F366 adjusts the derivative gain applied during PID control. This gain adjusts the response time of the drive to rapid changes in the process.

Control Loop Configuration

If FMOd (FREQUENCY MODE SEL) is set to 2, adjust parameters F201–F204 (for analog input control from VIA) or F210–F213 (for analog input control from VIB) according to the ranges in Table 19 to define the performance characteristics of the drive.

Table 19: Analog Input Control Parameters

Parameter	Name	Adjustment Range
F201	VIA reference point 1	0 to 100 (%)
F202	VIA frequency point 1	0 to 200 (Hz)
F203	VIA reference point 2	0 to 100 (%)
F204	VIA frequency point 2	0 to 200 (Hz)
F210	VIB reference point 1	0 to 100 (%)
F211	VIB frequency point 1	0 to 200 (Hz)
F212	VIB reference point 2	0 to 100 (%)
F213	VIB frequency point 2	0 to 200 (Hz)

Do not set the same frequency values for both VIA frequency points 1 (F202) and 2 (F204) or VIB frequency points 1 (F211) and 2 (F213). This will cause an Err1 error.

Figure 33: Analog Input Speed Reference and Output Frequency

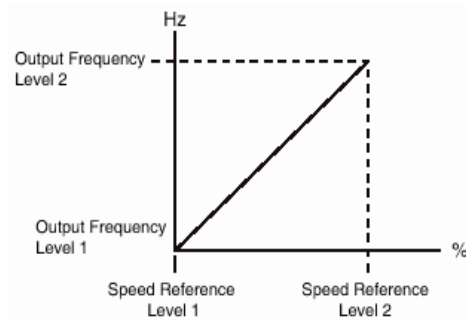

A refinement to the bias and slope of the analog input signals can be made with parameters F470–F473. Refer to the *Altivar 212 Programming and Operation Guide*, S1A53838.

Sleep/Wake Operation

Parameter	Name	Adjustment Range
F256	Sleep/Wake Operation Time	0 to 600 (s)

Setting parameter F256 enables Sleep/Wake Operation. If the drive operates continuously at low speed (LL) for a time period equal to the setting of F256 in seconds, the drive will ramp the motor to a stop.

While the motor is stopped, LStP will flash on the drive keypad until a speed reference above LL is provided. The factory setting is 0, which disables this function. By default LL is set to 15 Hz and can be modified.

Refer to the *Altivar 212 Programming and Operation Guide*, S1A53838, for more information.

PID Control Waiting Time

Parameter	Name	Adjustment Range
F359	PID Control Waiting Time	0 to 2400 s

By setting F359, the drive will not enter PID control until the time set by F359 has elapsed. The factory setting is 0, which disables this function. Factory default acceleration time is set at 60 seconds. If default acceleration time is changed or a factory reset is performed, adjust parameter F359 to match the desired acceleration and wait times.

Refer to the *Altivar 212 Programming and Operation Guide*, S1A53838, for more information.

Attain Speed Relay

Attain Speed Relay is only compatible with analog feedback control. Refer to the *Altivar 212 Programming and Operation Guide*, S1A53838, for additional relay configurations and settings.

Table 20: Attain Speed Relay Parameters

Parameter	Name	Setting	Adjustment Range	Description
F137	RYC–RYA Relay Secondary Function	60	—	To enable the run command signal relay (RA–RC and RYC–RYA) to include attain speed signal functionality, set parameter F137 to 60. The relay will only energize when the drive speed reference equals the VIB signal and a run command is received.
F167	Frequency command agreement detection range	—	0.0 to FH (Hz)	Parameter F167 determines the bandwidth around the VIB speed reference driving the relay output function.

Control Wiring

For analog PID control, wire terminals VIA, VIB, and CC as shown in Figure 34 (for two-wire loop powered) and in Figure 35 (for separately powered transducer).

- If the feedback is a 4–20 mA signal, set switch SW3 to the I (current) position.
- If the feedback is a 0–10 Vdc signal, set switch SW3 to the V (voltage) position.

Refer to the *Altivar 212 Installation Guide*, S1A53832, for instructions on accessing SW3.

Figure 34: Two-wire Loop Powered Transducer

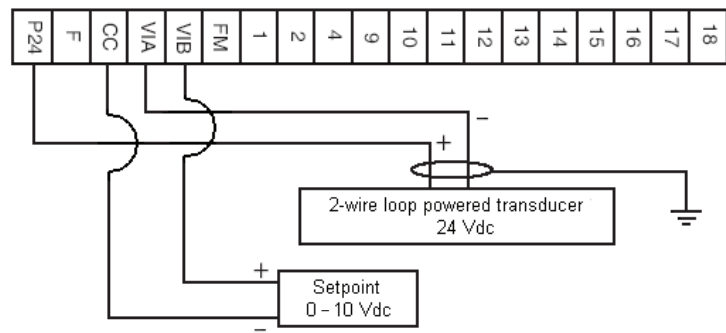

⚠ CAUTION
<p>UNINTENDED MOTOR SPEED</p> <p>Ensure adequate current for the transducer. The 24 Vdc power supply is current-limited to 200 mA. A load greater than the limit will cause the control voltage to dip and may result in erroneous readings from the transducer.</p> <p>Failure to follow these instructions can result in injury or equipment damage.</p>

Figure 35: Separately Powered Transducer

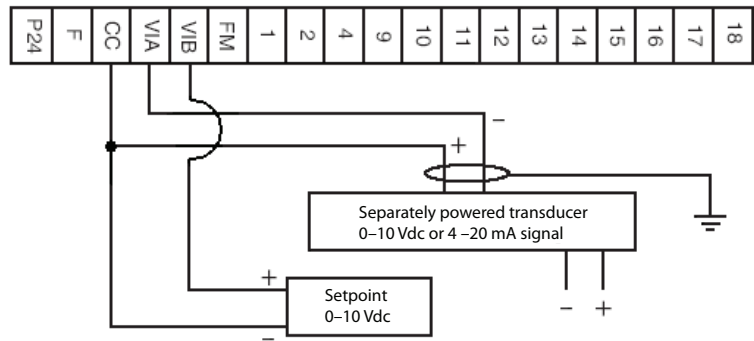

Ground the shield only at one end to prevent large currents from flowing in the shield. The shield on the ungrounded end may be tied to ground with a capacitor (for example, 10 nF, 100 V or higher) to provide a path for the higher frequency noise.

Application Notes

To set up the drive for a potentiometer using the drive supplied 10 Vdc supply or keypad speed reference, refer to the *Altivar 212 Installation Guide*, S1A53832, for additional details on power converter terminal block characteristics. Actual terminal arrangement and termination availability may vary depending on the communications option selected.

Programming the PID Internal Setpoint with the Keypad

Set the following parameter: = FNOd to 3. This allows you to program the internal setpoint with the keypad.

When a run command is issued the default display for the drive will be the is output frequency.

Press the Up or Down arrow button while watching the gauge that shows the actual value. Once the actual value reaches the point you want to maintain, press enter. The setpoint will be shown on the display in a percentage between Low Speed (LL) and High Speed (UL). For example, 30 is 50%. See “Graphic Keypad Option (D07)” on page 51.

Figure 36: Control Terminals

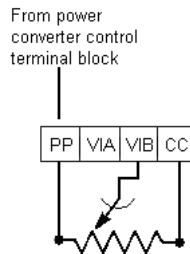

One internal 10 Vdc supply is accessible through terminal PP, integral to the power converter. Refer to Figure 36. The power supply is short-circuit and overload protected and capable of supplying up to 10 mA supply current. Size the reference potentiometer accordingly within a 1 to 10 k range. Connect the potentiometer as shown in Figure 36.

Set parameters CMOD and FMOd to the values shown in Table 21 to accept reference from the VIB terminal using the reference potentiometer.

Table 21: Parameters

Parameter	Name	Setting
CMOD	Control terminal logic input	0
FMOd	Remote mode primary speed reference source (VIB)	2

To control the PID reference setpoint from the keypad, press the Loc/Rem key at any time and provide a speed reference command from the keypad display using the UP/DOWN arrows.

NOTE: Parameter F732 must be set to 0 to enable Loc/Rem.

Refer to the *Altivar 212 Programming and Operation Guide*, S1A53838, for more information.

Section 6—Maintenance and Support

Precautions

Before replacing any parts in the S-Flex enclosed drive, read and observe the following safety messages and all other safety messages provided in this bulletin.

⚠ DANGER

HAZARD OF ELECTRIC SHOCK, EXPLOSION, OR ARC FLASH

- Read and understand this instruction bulletin before installing or operating the S-Flex drive. Installation, adjustment, repair, and maintenance must be performed by qualified personnel.
- The user is responsible for compliance with all international and national electrical code requirements with respect to grounding of all equipment.
- Many parts of this drive, including the printed circuit boards, operate at the line voltage. **DO NOT TOUCH.** Use only electrically insulated tools.
- Some terminals have voltage on them when the disconnect is open.
- **DO NOT** short across terminals PA/+ and PC/- or across the DC bus capacitors.
- Before servicing the drive:
 - Disconnect all power including external control power that may be present before servicing the drive.
 - Place a “DO NOT TURN ON” label on the drive disconnect.
 - Lock disconnect in the open position.
 - **WAIT 15 MINUTES** to allow the DC bus capacitors to discharge. Then follow the “DC Bus Voltage Measurement Procedure” on page 40 to verify that the DC voltage is less than 42 V. The drive LEDs are not indicators of the absence of DC bus voltage.
- Install and close all covers and doors before applying power or starting and stopping the drive.

Failure to follow these instructions will result in death or serious injury.

⚠ DANGER

HAZARD OF ELECTRIC SHOCK, EXPLOSION, OR ARC FLASH

For 460 V units:

- Apply appropriate personal protective equipment (PPE) and follow safe electrical work practices. See NFPA 70E or CSA Z462.
- This equipment must only be installed and serviced by qualified electrical personnel.
- Never operate energized switch with door open.
- Turn off switch before removing or installing fuses or making load side connections.
- Always use a properly rated voltage sensing device at all line and load fuse clips to confirm switch is off.
- Turn off power supplying switch before doing any other work on or inside switch.
- Do not use renewable link fuses in fused switches.

Failure to follow these instructions will result in death or serious injury.

⚠ DANGER

HAZARD OF ELECTRIC SHOCK, EXPLOSION, OR ARC FLASH

For 208 and 230 V units:

- Apply appropriate personal protective equipment (PPE) and follow safe electrical work practices. See NFPA 70E or CSA Z462.
- This equipment must be installed and serviced only by qualified electrical personnel.
- Turn off all power supplying this equipment before working on or inside the equipment.
- Always use a properly rated voltage sensing device to confirm power is off.
- Replace all devices, doors and covers before turning on power to this equipment.

Failure to follow these instructions will result in death or serious injury.

⚠ DANGER

UNINTENDED EQUIPMENT OPERATION

Before turning on the drive or upon exiting the configuration menus, ensure that the inputs assigned to the Run command are in a state that will not cause the drive to run. Otherwise, the motor can start immediately.

Failure to follow these instructions will result in death, or serious injury.

⚠ WARNING

LOSS OF CONTROL

- The designer of any control scheme must consider the potential failure modes of control paths and, for certain critical control functions, provide a means to achieve a safe state during and after a path failure. Examples of critical control functions are emergency stop and overtravel stop.
- Separate or redundant control paths must be provided for critical control functions.
- System control paths may include communication links. Consideration must be given to the implications of anticipated transmission delays or failures of the link¹.
- Each implementation of an S-Flex enclosed drive must be individually and thoroughly tested for proper operation before being placed into service.

Failure to follow these instructions can result in death, serious injury, or equipment damage.

¹ For additional information, refer to NEMA ICS 1.1 (latest edition), "Safety Guidelines for the Application, Installation, and Maintenance of Solid State Control" and to NEMA ICS 7.1 (latest edition), "Safety Standards for Construction and Guide for Selection, Installation and Operation of Adjustable-Speed Drive Systems."

⚠ CAUTION

INCOMPATIBLE LINE VOLTAGE

Before turning on and configuring the drive, ensure that the line voltage is compatible with the line voltage range specified on the drive nameplate. The drive can be damaged if the line voltage is not compatible.

Failure to follow these instructions can result in injury or equipment damage.

Diagnostic Codes

A number of diagnostic and status codes are included on the power converter. See the Troubleshooting Sheet on page 89. The graphic display terminal provides a visual indication of the controller's operating and protective circuit functions, as well as indicator lights for maintenance and troubleshooting assistance.

If the controller trips while operating, the codes must be viewed before power is removed because removing power resets the detected fault code.

External Signs of Damage

The following are signs of external damage:

- Cracked, charred, or damaged covers or enclosure parts
- Damage to the graphic display terminal such as scratches, punctures, burn marks, chemical burns, or moisture in the screen
- Oil or electrolyte on the bottom of the drive which might have leaked from the capacitors inside
- Excessive surface temperatures of enclosures and conduits
- Damage to power or control conductors
- Unusual noise or odors from any of the equipment
- Abnormal temperature, humidity, or vibration

If any of these signs are found while the equipment is powered up, immediately inform operating personnel and assess the risk of leaving the drive system powered up. Before removing power from the equipment, always consult with the operating personnel responsible for the machinery and process.

Preventive Maintenance

Table 22: Recommended Maintenance Intervals

Inspection ¹	Interval (years)																			
	1	2	3	4	5	6	7	8	9	10	11	12	13	14	15	16	17	18	19	20
Line side terminals and torque				√				√				√				√				√
Load side terminals and torque				√				√				√				√				√
Plug-in connections				√				√				√				√				√
Relay contacts						√						√						√		
Circuit boards						√						√						√		
Insulation damage		√		√		√		√		√		√		√		√		√		√
Fiber optic cables				√				√				√				√				√
Oxidation, corrosion, dust	√	√	√	√	√	√	√	√	√	√	√	√	√	√	√	√	√	√	√	√
Power supply LEDs				√				√				√				√				√
Gasket						√						√						√		
DC-link capacitors						√						√						√		
Circuit breaker inspection				√				√				√				√				√
Spare part inspection				√				√				√				√				√
Air filter ²	√	√	√	√	√	√	√	√	√	√	√	√	√	√	√	√	√	√	√	√
Heat sinks (dust and debris)		√		√		√		√		√		√		√		√		√		√
Change	1	2	3	4	5	6	7	8	9	10	11	12	13	14	15	16	17	18	19	20
Fan(s) for control electronics				√				√				√				√				√
Fan(s) for power electronics				√				√				√				√				√
Enclosure fan(s)				√				√				√				√				√
DC-link capacitors												√								√
Enclosure filters				√				√				√				√				√
Service	1	2	3	4	5	6	7	8	9	10	11	12	13	14	15	16	17	18	19	20
Capacitor reforming				√				√				√				√				√
Thermography				√				√				√				√				√
Current symmetry				√				√				√				√				√
Check of parameter setting				√				√				√				√				√

¹ All service must be done with the controller in a non-energized state.

² Clear the fan filters once every six months.

Inspection

Periodic inspection of the equipment is recommended to maintain the functionality over the course of its lifetime.

- Inspect the heatsink fans of the controller for blockage and impeded rotation. To prevent overheating and to allow proper air flow, maintain the clearances described on page 31.
- Examine the interior and exterior of the controller for moisture, oil, or other foreign material. Remove all foreign material and clean the controller.
- Clean the interior and exterior of the controller with a vacuum, do not use compressed air; it may distribute foreign contaminants to other surfaces.
- Check the enclosure for damage that might reduce electrical clearances.
- Examine the finish of the enclosure. Touch up the paint if necessary. Replace any badly oxidized, corroded or damaged enclosure parts.

Maintenance after a Downstream Fault Has Occurred

Excessive currents during a downstream fault may result in component or conductor damage. This damage is caused by mechanical distortion, thermal damage, metal deposits, or smoke from downstream short circuit or thermal overload currents.

After a downstream fault, locate and correct the cause of the fault. Inspect all equipment and make any necessary repairs or replacements before putting the equipment back into service. Make sure all replacement parts are rated properly and are suitable for the application. If in doubt, consult your Schneider Electric field sales representative.

After any downstream fault, perform the following maintenance procedures:

1. Examine the enclosure. External evidence of enclosure damage usually indicates damage within. Extensive damage requires replacement of the enclosure parts or the equipment entirely.
2. Replace any parts that are damaged or deformed. Pay particular attention to door hinges and door closing hardware. Inspect the area around any damaged units (both inside and out) for displaced parts from the damaged unit.
3. Examine all conductors and tighten all electrical connections to their proper torque values. Replace any damaged conductors, as well as any showing signs of arcing damage. Inspect all insulators for cracks or burn marks and replace any displaying these characteristics.

Circuit Breaker Maintenance

Some S-Flex drives are supplied with circuit breakers. Before performing any test or maintenance on the circuit breaker, locate the upstream disconnecting device and lock-out the power feeding the circuit breaker.

Press the push-to-trip button once a year to exercise the circuit breaker. Do not perform this test under load.

NOTE: The push-to-trip button will not function when the circuit breaker handle is in the Off (O) position.

Technical Support

When troubleshooting the S-Flex enclosed drive, discuss the symptoms of the reported problems with operating personnel. Ask them to describe the problem, identify when they first observed the problem, and where the problem was seen.

Observe the drive system and process. Record the drive motor and peripheral equipment nameplate data on the Troubleshooting Sheet provided on page 89. Copy this form as needed.

S-Flex 212 TROUBLESHOOTING SHEET

When requesting after-sales service, it is important to disclose all conditions under which the Schneider Electric equipment currently operates. This will help in diagnosing the system quickly.

Call the Product Support Group at 888-778-2733.

DATE: _____
 CONTACT NAME: _____
 COMPANY: _____
 ADDRESS: _____
 CITY: _____
 STATE: _____
 PHONE: _____
 FAX: _____

DRIVE CONFIGURATION

CATALOG NUMBER: TYPE **SFD212**:
 APPLICATION/EQUIPMENT DESIGNATION:

MOTOR NAMEPLATE DATA

HORSEPOWER: _____ VOLTAGE (3 PHASE): _____ FREQUENCY: _____ RPM: _____ FLA: _____
 SERVICE FACTOR: _____ MOTOR INSULATION: NEW OR EXISTING
 MOTOR CABLE TYPE: _____ LENGTH IN FEET: _____
 IS MOTOR DESIGNED TO COMPLY WITH NEMA MG-1 PART 31 GUIDELINES? YES NO

POWER SOURCE AND ENVIRONMENT

VOLTAGE BETWEEN: L1 AND L2: _____ L2 AND L3: _____ L3 AND L1: _____
 SERVICE TRANSFORMER RATING: _____ KVA _____ % Z FREQUENCY: 60 HZ OR 50 HZ
 AMBIENT TEMPERATURES: MIN °C (°F) _____ MAX °C (°F) _____ HUMIDITY: _____
 ALTITUDE IF GREATER THAN 3300 FEET ABOVE SEA LEVEL, SPECIFY: _____ FT

DRIVE DETECTED FAULT CODES

Refer to the *Altivar 212 Programming and Operation Guide*, S1A53838 for possible causes, corrective actions, and additional detected fault codes.

<input type="checkbox"/> E-19	<input type="checkbox"/> Err7	<input type="checkbox"/> OC3P	<input type="checkbox"/> OP1
BREAK IN VIA SIGNAL CABLE	CURRENT SENSOR	GROUND CONSTANT SPEED	OVERVOLTAGE ACCELERATION
<input type="checkbox"/> E-21	<input type="checkbox"/> EtYP	<input type="checkbox"/> OCL	<input type="checkbox"/> OP2
CPU	DRIVE TYPE	SHORT CIRCUIT	OVERVOLTAGE DECELERATION
<input type="checkbox"/> EF2	<input type="checkbox"/> OC1	<input type="checkbox"/> OH	<input type="checkbox"/> OP3
GROUND FAULT	OVERCURRENT ACCELERATION	OVERTEMPERATURE	OVERVOLTAGE CONSTANT SPEED
<input type="checkbox"/> EPH1	<input type="checkbox"/> OC1P	<input type="checkbox"/> OL1	<input type="checkbox"/> Ot
INPUT PHASE LOSS	GROUND FAULT ACCELERATION	DRIVE OVERLOAD	OVERTORQUE FAULT
<input type="checkbox"/> EPH0	<input type="checkbox"/> OC2P	<input type="checkbox"/> OL2	<input type="checkbox"/> UC
OUTPUT PHASE LOSS	GROUND FAULT	MOTOR OVERLOAD	UNDERLOAD FAULT

DETAILED DESCRIPTION OF PROBLEM

Renewable Parts

Schneider Electric provides a limited number of renewable parts for the Altivar 212 power converters and the S-Flex enclosed drives. Before replacing any parts, consult your local field sales representative. Renewable parts must be installed by qualified personnel.

Table 23: Recommended Renewable Parts

Renewable Part	208 V Rating		230 V Rating		460 V Rating		
Power Converter¹							
	1 hp	ATV212H075M3X	ATV212H075M3X	ATV212H075M3X	ATV212H075N4		
	2 hp	ATV212HU15M3X	ATV212HU15M3X	ATV212HU15M3X	ATV212HU15N4		
	3 hp	ATV212HU22M3X	ATV212HU22M3X	ATV212HU22M3X	ATV212HU22N4		
	5 hp	ATV212HU40M3X	ATV212HU40M3X	ATV212HU40M3X	ATV212HU40N4		
	7.5 hp	ATV212HU55M3X	ATV212HU55M3X	ATV212HU55M3X	ATV212HU55N4		
	10 hp	ATV212HU75M3X	ATV212HU75M3X	ATV212HU75M3X	ATV212HU75N4		
	15 hp	ATV212HD11M3X	ATV212HD11M3X	ATV212HD11M3X	ATV212HD11N4		
	20 hp	ATV212HD15M3X	ATV212HD15M3X	ATV212HD15M3X	ATV212HD15N4		
	25 hp	ATV212HD18M3X	ATV212HD18M3X	ATV212HD18M3X	ATV212HD18N4		
	30 hp	ATV212HD22M3X	ATV212HD22M3X	ATV212HD22M3X	ATV212HD22N4		
	40 hp	ATV212HD30M3X	ATV212HD30M3X	ATV212HD30M3X	ATV212HD30N4		
	50 hp	—	—	—	ATV212HD37N4		
	60 hp	—	—	—	ATV212HD45N4		
	75 hp	—	—	—	ATV212HD55N4		
	100 hp	—	—	—	ATV212HD75N4		
FB1, FB2, FB3 Power Fuses²						Rating (A)	Class
	1 hp	—	—	25430-20300	3	CC	
	2 hp	—	—	25430-20600	6	CC	
	3 hp	—	—	25430-20700	7	CC	
	5 hp	—	—	25430-21500	15	CC	
	7.5 hp	—	—	25430-21500	15	CC	
	10 hp	—	—	25430-22000	20	CC	
	15 hp	—	—	25430-23000	30	CC	
	20 hp	—	—	25423-30400	40	J	
	25 hp	—	—	25423-30500	50	J	
	30 hp	—	—	25423-30600	60	J	
	40 hp	—	—	25423-30800	80	J	
	50 hp	—	—	25423-31000	100	J	
	60 hp	—	—	25423-31000	100	J	
	75 hp	—	—	25423-31500	150	J	
	100 hp	—	—	25423-31750	175	J	
FU2, FU3							
		Rating (A)	Class		Rating (A)	Class	
Control Power Transformer (Primary Fuse)	25430-20350 ³	3.5	CC	25430-20321 ³	3.2	CC	
	25430-20225 ⁴	2.25	CC	25430-20200 ⁴	2	CC	
Control Power Transformer (Secondary Fuse)	25430-20200 ³	2	CC	25430-20200 ³	2	CC	
	25430-20140 ⁴	1.4	CC	25430-20140 ⁴	1.4	CC	

¹ Drives shown in the table are installed in SFD212 controllers.

² Use Class CC or J fast acting fuses. Control power transformer and fuses are supplied only with power circuit Y05.

³ Fuses are supplied for 15 to 40 hp, 208/230 V and 25 to 100 hp, 460V with MOD B07.

⁴ Fuses are supplied for all power ratings without MOD B07. Fuses are supplied for 1 to 10 hp, 208/230 V and 1 to 20 hp, 260 V with MOD B07.

Table 24: S-Flex ByPass Circuit Power Component Renewable Parts (Mod Y Only), Square D Catalog Numbers

S-Flex Drive Catalog Number	Input Voltage (60 Hz Vac)	Horsepower Rating (hp)	Main Circuit Breaker	Drive Input, Drive Output, or Bypass Contactor	Motor Overload Relay	
SFD212CG2	208	1	HLL36015LV	LC1D25G7	LRD10	
SFD212DG2		2	HLL36020LV	LC1D25G7	LRD12	
SFD212EG2		3	HLL36025LV	LC1D25G7	LRD16	
SFD212FG2		5	HLL36040LV	LC1D25G7	LRD21	
SFD212GG2		7.5	HLL36060LV	LC1D32G7	LRD32	
SFD212HG2		10	HLL36080LV	LC1D32G7	LRD32	
SFD212JG2		15	HLL36110LV	LC1D50AG7	LRD350	
SFD212KG2		20	HLL36150LV	LC1D65AG7	LRD365	
SFD212LG2		25	HLL36100M73LV	LC1D80G7	LRD3363	
SFD212MG2		30	HLL36150M74LV	LC1D115G7	LRD4365	
SFD212NG2		40	HLL36150M74LV	LC1D150G7	LR9D5369	
SFD212CG3		230	1	HLL36015LV	LC1D25G7	LRD10
SFD212DG3			2	HLL36020LV	LC1D25G7	LRD12
SFD212EG3	3		HLL36025LV	LC1D25G7	LRD14	
SFD212FG3	5		HLL36035LV	LC1D25G7	LRD21	
SFD212GG3	7.5		HLL36060LV	LC1D32G7	LRD22	
SFD212HG3	10		HLL36070LV	LC1D32G7	LRD32	
SFD212JG3	15		HLL36100LV	LC1D50AG7	LRD350	
SFD212KG3	20		HLL36125LV	LC1D65AG7	LRD365	
SFD212LG3	25		HLL36100M73LV	LC1D80G7	LRD3363	
SFD212MG3	30		HLL36150M74LV	LC1D115G7	LRD4365	
SFD212NG3	40	HLL36150M74LV	LC1D150G7	LRD4367		
SFD212CG4	460	1	HLL36015LV	LC1D25G7	LRD07	
SFD212DG4		2	HLL36015LV	LC1D25G7	LRD08	
SFD212EG4		3	HLL36015LV	LC1D25G7	LRD10	
SFD212FG4		5	HLL36020LV	LC1D25G7	LRD14	
SFD212GG4		7.5	HLL36025LV	LC1D25G7	LRD16	
SFD212HG4		10	HLL36035LV	LC1D25G7	LRD21	
SFD212JG4		15	HLL36050LV	LC1D32G7	LRD22	
SFD212KG4		20	HLL36060LV	LC1D32G7	LRD32	
SFD212LG4		25	HLL36080LV	LC1D50AG7	LRD340	
SFD212MG4		30	HLL36100LV	LC1D50AG7	LRD340	
SFD212NG4		40	HLL36125LV	LC1D65AG7	LRD365	
SFD212PG4		50	HLL36150LV	LC1D80G7	LRD3363	
SFD212QG4		60	HLL36100M73LV	LC1D80G7	LRD3363	
SFD212RG4		75	GS1MU3S02 ¹	LC1D150G7	LRD4367	
SFD212SG4		100	GS1MU3S02 ¹	LC1D150G7	LR9D5369	

¹ Denotes Fusible Switch used for these power ratings instead of Main Circuit Breaker

Table 25: S-Flex ByPass Circuit Control Component Renewable Parts (Mod Y Only)—All Sizes, Square D Catalog Numbers

AFC/OFF/ByPass 3-Position Selector Switch	ZB5AD3 + ZB5AZ009 + (2) ZBE203
Red Power On LED	80462-110-01
Green ByPass Run LED	80462-109-01

**S-Flex™ Adjustable Speed Enclosed Drive
Instruction Bulletin**

Electrical equipment should be installed, operated, serviced, and maintained only by qualified personnel. No responsibility is assumed by Schneider Electric for any consequences arising out of the use of this material.

Altivar™, Mag-Gard™, Modbus™, PowerPact™, S-Flex™, Schneider Electric™ and Square D™ are trademarks or registered trademarks of Schneider Electric. Other trademarks used herein are the property of their respective owners.

30072-451-83 Rev. 02, 12/2012
Replaces 30072-451-83 Rev. 01, 06/2011
© 2007–2012 Schneider Electric All Rights Reserved