

Flush Service Floor Boxes

Carpet Plates for 671 and 672 Floor Boxes

- Polished-brass finish
- Furnished complete with 6-32 x 1"-long brass flathead screws and gasket
- For brushed aluminum, add AL after catalog number
- 3 $\frac{3}{8}$ " outside diameter



P-90-CP



| CAT. NO. | DESCRIPTION | STD. CTN. |
|------------|-------------------------|-----------|
| P-90-CP | Carpet Plate — Brass | 4 |
| P-90-CP-AL | Carpet Plate — Aluminum | 4 |

Accessories for 671 and 672 Floor Boxes

- Use brass edge ring for neat appearance when non-adjustable floor box is installed in concrete
- Edge ring has 3 $\frac{3}{4}$ " OD and adds $\frac{3}{8}$ " to floor box height
- 15-amp, 125-volt, NEMA grounding type
- Mounted on steel seating plate
- For use with 2" diameter opening floor plate



P-67-F Edge Ring



478-G-12 Short Strap Receptacle



| CAT. NO. | DESCRIPTION | STD. CTN. |
|----------|--|-----------|
| P-67-F | Brass Edge Ring for Concrete | 4 |
| 478-G-12 | 15-Amp, 125-Volt NEMA Grounding Receptacle | 4 |

Floor Plate Plug Inserts for 78, 88, 671 or 672 Series



| CAT. NO. | SIZE OR DESCRIPTION | STD. CTN. |
|----------|---------------------------|-----------|
| 690-SC | 1/2"-14" NPS Thread | 4 |
| 691-SC | 3/4"-14" NPS Thread | 4 |
| 692-SC | 1"-11 1/2" NPS Thread | 4 |
| 693-SC | 1 1/4"-11 1/2" NPS Thread | 4 |
| 694 | 2"-20" UN Thread | 4 |
| 695 | 1/2"-2" | 4 |
| 696-SC | 3/4"-2" | 4 |
| 697 | 2 5/8"-20" UN 2A Thread | 4 |
| 698 | 1 7/8" for Duplex P-60-DU | 4 |

For standard plug inserts 1/2" through 2", see **page A-155**

Catalog numbers are for brass.

For aluminum, add AL after catalog number.

Floor Box Body Parts

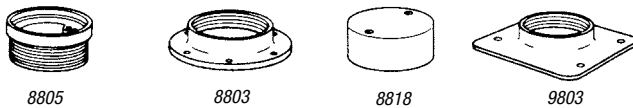

| CAT. NO. | DESCRIPTION | STD. CTN. |
|----------|---|-----------|
| 8805 | Brass Adjusting Ring | 4 |
| 8803 | Threaded Steel Body Cover of 78 and 88 Series | 4 |
| 8818 | Metal Protective Cap | 4 |
| 9803 | Threaded Steel Body Cover for 98 Series | 4 |

2 5/8"-20 UN 2A Thread.

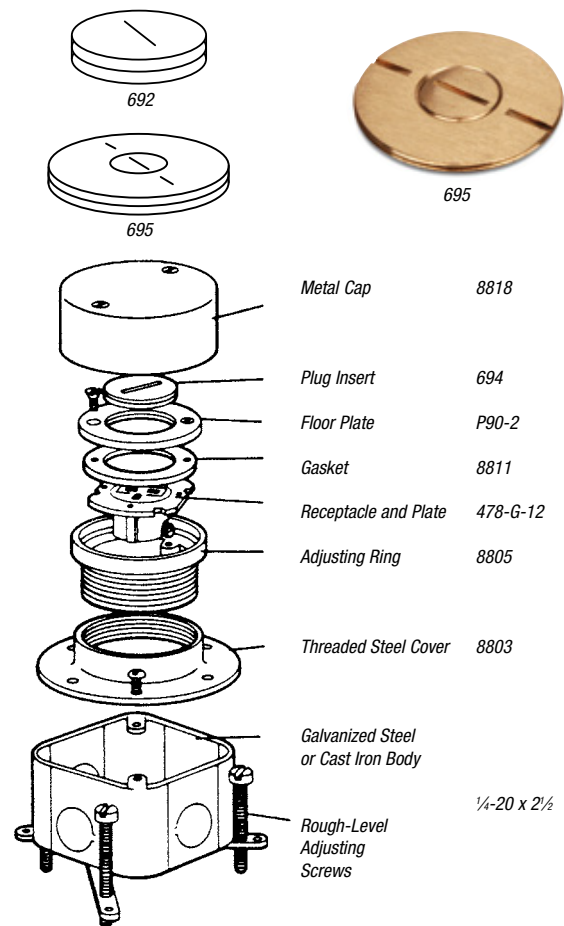

Floor Box Assembly with Floor Plate