



Long-life energy saving lamp

Wall-mount lamp holder



Technical Data

Power consumption	20W (~ 100W incandescent bulb)
Luminosity	1000Lm
Lamp type	compact fluorescent, E27 base, electronic ballast
Service life	10,000 hrs.
Connection	integrated power cable (6 ft.) with US or Euro plug
Housing	plastic, UL 94V-0, light grey
Mounting	screws or self-adhesive mounting plate (included)
Mounting position	variable
Operating temperature	-4 to +122°F (-20 to +50°C)
Storage temperature	-49 to +158°F (-45 to +70°C)
Weight	approx. 1.3 lbs. (600g)
Protection class	II (double insulated)
Protection type	IP20

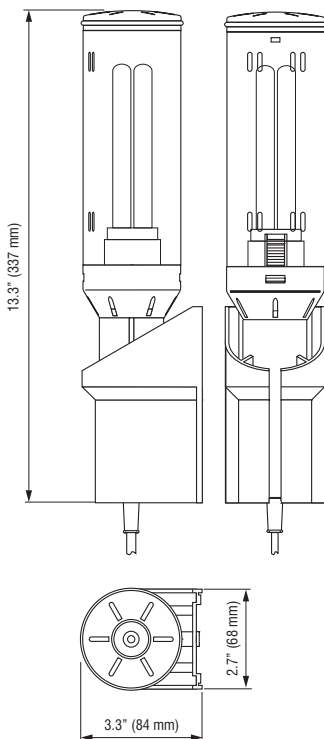

Part No.	Operating voltage	Plug type
02610.0-00	230VAC, 50/60Hz	Euro
02610.9-00	120VAC, 50/60Hz	US

Specifications are subject to change without notice. Suitability of this product for its intended use and any associated risks must be determined by the end customer/ buyer in its final application.