

INSTALLATION INSTRUCTIONS FOR SYMCOM'S LOAD SENSOR MODEL LSR-0

**BE SURE POWER IS DISCONNECTED PRIOR TO INSTALLATION!!
FOLLOW NATIONAL, STATE AND LOCAL CODES!**

CONNECTIONS

1. Mount the Model LSR-0 near one of the conductors of the load which is to be monitored. If the unit is in a wet or dusty environment, a NEMA 4 or 12 enclosure should be used. Install according to all local, state and national electric codes.
2. Insert one of the conductors of the load which is to be monitored through the sensor hole in the Model LSR-0. If the conductor current is less than 15 Amps, multiple passes must be made. Refer to Table No. 1 for the number of required passes.
3. Connect the Model LSR-0 contacts to the desired control circuit. Refer to Figure No. 1 for typical wiring diagrams.

Conductor Amps	Number of Conductor Passes Required
>15	1
8 - 15	2
5 - 8	3
4 - 5	4
3 - 4	5
2 - 3	8
1 - 2	15

Table No. 1: Number of Conductor Passes Required Through the Model LSR-0 Sensor Hole

Amperage Ratings	135A Continuous
Turn-on Threshold	Fixed, 15A (max.)
Turn-off Threshold	2.5 Amps (min.)
Power	Induced from conductor
Isolation	600 VAC rms
Output Ratings	480 VA @ 240 VAC

Visit our website at www.symcominc.com for our complete catalog and new product listings!



2880 North Plaza Drive, Rapid City, SD 57702 • (800) 843-8848

TYPICAL WIRING DIAGRAM FOR BACK-UP PUMP OPERATION

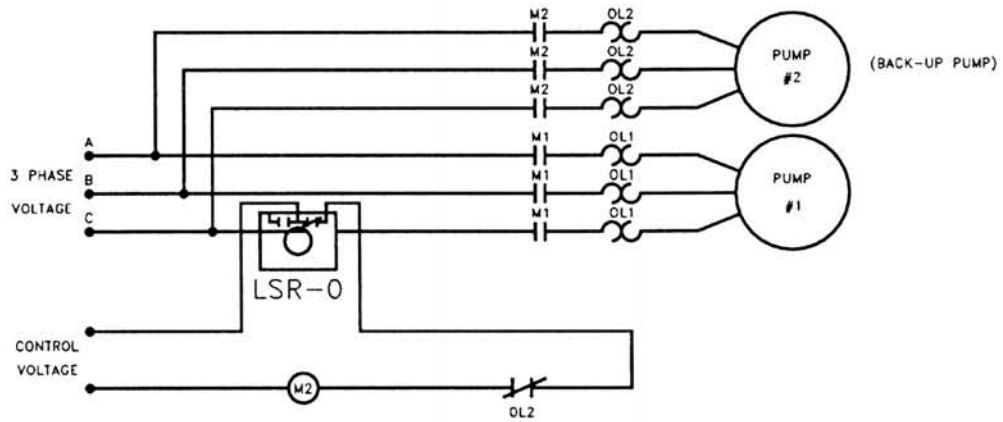

TYPICAL WIRING DIAGRAM FOR PROCESS CONTROL

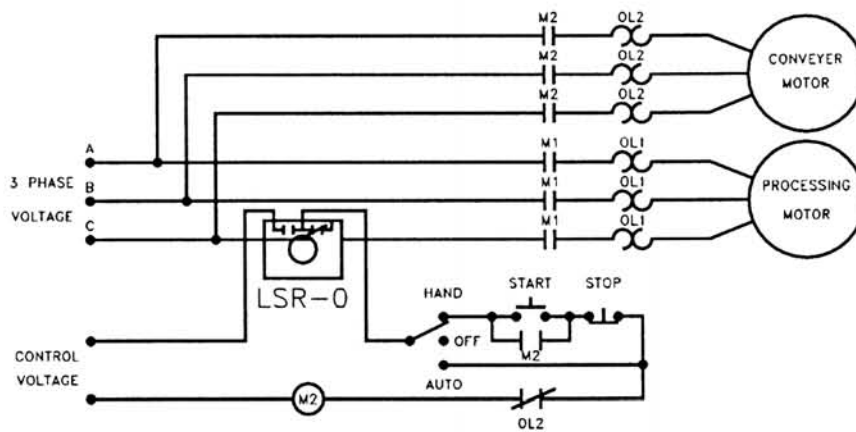

TYPICAL WIRING DIAGRAM FOR COMPRESSOR MOTORS

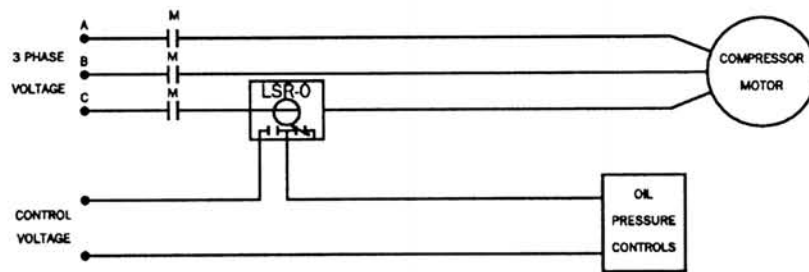

TYPICAL WIRING DIAGRAM FOR BUILDING AUTOMATION

