

MODEL PC-102CICI-DL



II_PC-102CICI-DL_B1

DANGER!



HAZARDOUS VOLTAGES MAY BE PRESENT DURING INSTALLATION.

Electrical shock can cause death or serious injury.

Installation should be done by qualified personnel following all national, state and local electrical codes.



**BE SURE POWER IS DISCONNECTED PRIOR TO INSTALLATION!
FOLLOW NATIONAL, STATE AND LOCAL CODES.
READ THESE INSTRUCTIONS ENTIRELY BEFORE INSTALLATION.**

SymCom's PC-102CICI-DL is a dual seal-leak detector with two isolated form C output relays. The input resistance threshold can be set from 4.7k – 100kΩ. A pulsed DC voltage is applied to the probes, which prevents corrosion and build-up on the probes.

CONNECTIONS

1. Mount the PC-102 on 35mm DIN rail, or by installing two #6 – #8 screws into the surface mounting holes provided.
2. Connect inputs and outputs according to the typical wiring diagram below. Switches or resistive probes can be used on the inputs. The PC-102 must be powered by 120VAC connected to terminals 2 and 3.

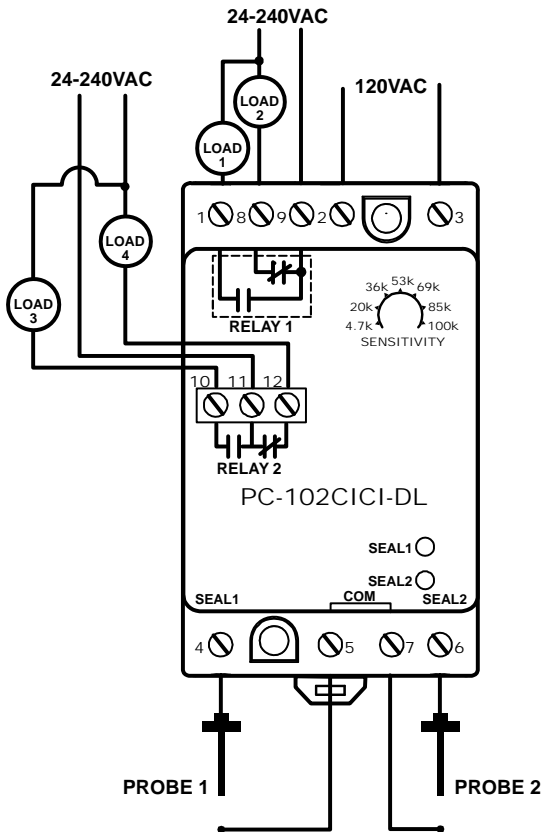

Figure 1: Typical Wiring Diagram

(Relays are shown in their normal/non-energized states.)

SETTINGS

Input	DIP Switch	OFF	ON
SEAL 1	S1	direct logic	inverted logic
	S2	0.5-sec. debounce	2-sec. debounce
SEAL 2	S3	direct logic	inverted logic
	S4	0.5-sec. debounce	2-sec. debounce

Table 1: DIP Switch Settings

OPERATION

When the resistance measured at an input is greater than the sensitivity setting, the corresponding output relay is de-energized—in its normal state. When the input resistance drops below the sensitivity setting (water is detected), the associated output relay is energized. The input logic may be reversed/inverted using DIP switches on the side of the device. Refer to Table 1 for setting the logic for each input.

The PC-102CICI-DL can utilize either a 0.5-second or 2-second debounce time delay. The output contact will not change states until a fault condition exists for this time period. Refer to Table 1 for setting the debounce time delay for each input.

Red LEDs illuminate on the PC-102CICI-DL when the associated output relay is energized.

DIMENSIONS

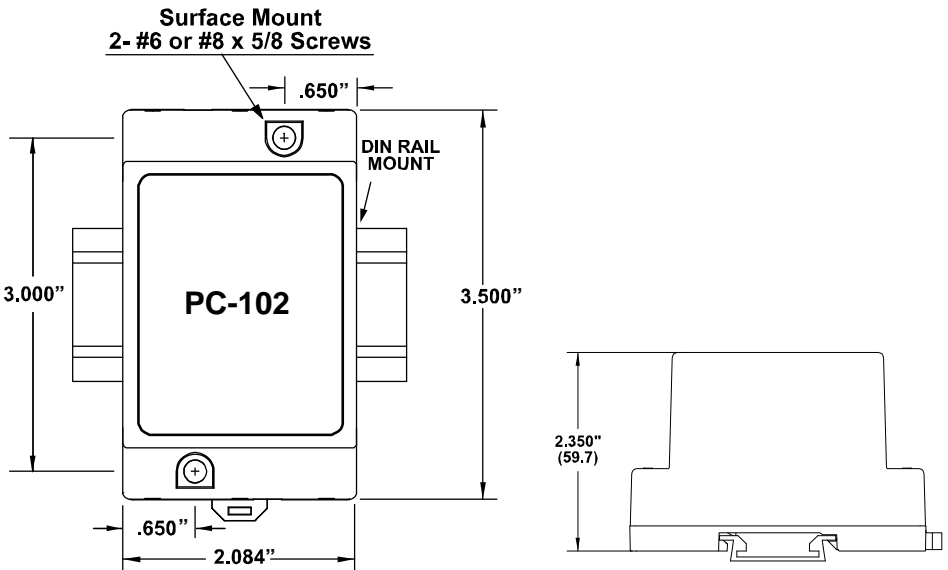

Figure 2: Dimensions

Model PC-102CICI-DL SPECIFICATIONS	
Functional Characteristics	
Adjustments	
Sensitivity	4.7k – 100kΩ
Input Logic	Direct or inverted
Debounce Time Delay	0.5 or 2 seconds
Probe Voltage	Pulsed 5V DC
Input Characterisitcs	
Voltage Range	120VAC
Frequency	50/60 Hz
Output Characteristics	
Pilot Duty	180VA @ 120VAC, C150
General Purpose	5Amps @ 240VAC
Depluggable Connector (included)	Phoenix Contact - Series MSTB plugs (or equivalent)
General Characteristics	
Weight	9 oz.
Torque	6 in.-lbs. (max.)
Wire AWG	12–20 AWG
Safety Marks	
UL Listed	UL508 (File #E68520)
cUL	C22.2 No. 14
Standards Passed	
Electrostatic Discharge (ESD)	IEC 61000-4-2, Level 3, 6 kV contact, 8 kV air
Radio Frequency Immunity, Radiated	IEC 61000-4-2, Level 3, 10V/m
Fast Transient Burst	IEC 61000-4-4, Level 3, 4 kV input power 2 kV inputs/outputs
Environmental	
Temperature Range	-20 to 55° C

For warranty information, please see **Terms and Conditions** at
www.symcom.com

*Visit us at www.symcom.com to see
our complete product listing!*

*Can't find what
you're looking for?*

*SymCom designs and manufactures
custom control boards too.
Call us for details!*