

# INSTALLATION INSTRUCTIONS

Revision A1  
Rapid City, SD, USA, 08/2009

# Motors<sup>®</sup>Saver

ELECTRONIC MOTOR  
CONTROL & PROTECTION

## MODEL 201-XXX-SP-DPDT



IL\_201-XXX-SP-DPDT\_A1

## **DANGER!**



**HAZARDOUS VOLTAGES MAY BE PRESENT DURING INSTALLATION.**

Electrical shock can cause death or serious injury.

Installation should be done by qualified personnel following all national, state and local electrical codes.



**BE SURE POWER IS DISCONNECTED PRIOR TO INSTALLATION!  
FOLLOW NATIONAL, STATE AND LOCAL CODES.  
READ THESE INSTRUCTIONS ENTIRELY BEFORE INSTALLATION.**

SymCom's MotorSaver<sup>®</sup> Model 201-XXX-SP-DPDT is a voltage monitor designed to protect single-phase motors regardless of size. The MotorSaver<sup>®</sup> is used on 120V or 240V, 50<sup>1</sup>/60 Hz motors to protect from damage caused by low voltage. The 201-XXX-SP-DPDT products feature two isolated Form C relay outputs.

### **CONNECTIONS**

1. Mount the MotorSaver<sup>®</sup> in a convenient location in or near the motor control panel. If the location is wet or dusty, it should be mounted in a NEMA 4 or 12 enclosure.
2. Mount the SymCom P/N OT08 socket to the motor control back panel.
3. Connect L1 and L2 (terminals 2 & 7 on the relay socket) to the LINE SIDE of the motor starter (Figure 2).
4. Connect the output relays to the circuitry to be controlled. For motor control, connect a normally open contact in series with the magnetic coil of the motor starter as shown in Figure 2. The 201-XXX-SP-DPDT has two sets of isolated relay contacts so that two separate circuits can be connected. For alarm operation, connect a normally closed contact in series with the control circuit as in Figure 2.
5. Plug the relay into the relay socket.

---

<sup>1</sup> 50 Hz will increase all delay times by 20%.

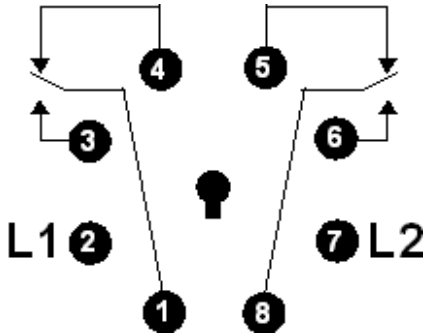

**Figure 1: Pin-Out Diagram**

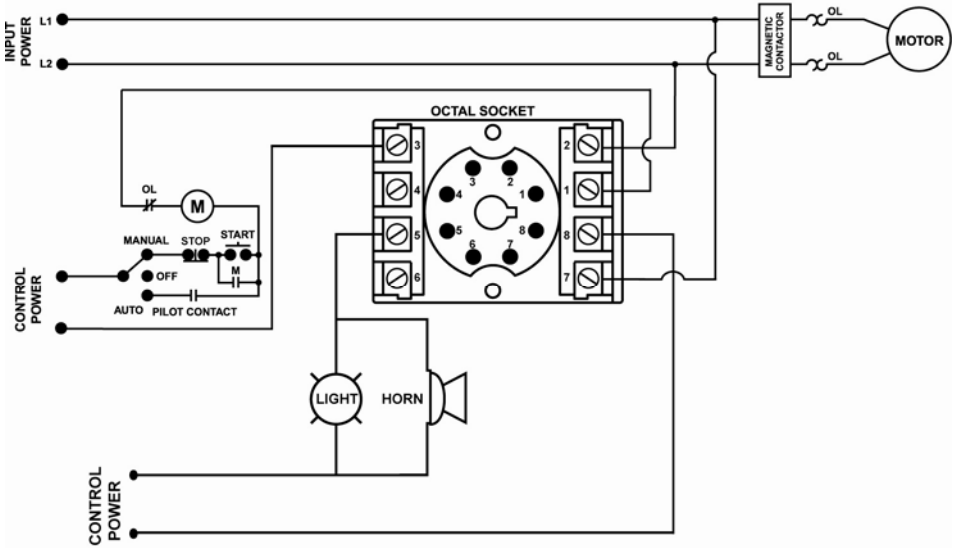

**Figure 2: Typical Wiring Diagram for MODEL 201-XXX-SP-DPDT  
With Motor & Alarm Control**

## SETTING

**LINE VOLTAGE ADJUSTMENT:** Rotate the **VOLT ADJUSTMENT (VAC)** knob to the nominal line voltage feeding the motor to be protected.

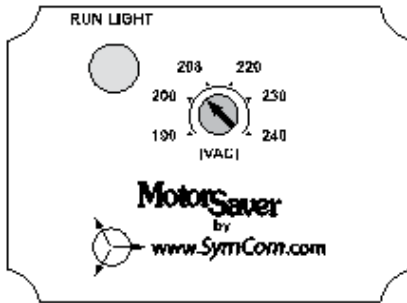

**Figure 3: Voltage Adjustment (201-100-SP-DPDT Model Shown)**

## OPERATION

Apply power to the motor. The MotorSaver's green RUN light will blink during the 2 second restart delay. Once the restart delay time has expired, the MotorSaver® will energize its output contacts and the green RUN light will illuminate.

If the contacts do not energize and the green RUN light does not illuminate, see the troubleshooting section.

STATUS	LIGHT PATTERN
RUN	GREEN
RESTART DELAY	 GREEN
LOW VOLTAGE	RED

**Table 1: Diagnostic Indicator Lights**

## TROUBLESHOOTING

<b>SYMPTOM</b>	<b>LIGHT PATTERN</b>	<b>SOLUTION</b>
No lights are on - the unit seems completely dead	<b>N/A</b>	Measure the voltage. If the Line Supply voltage is extremely low, the MotorSaver <sup>®</sup> does not have enough power to operate its internal electronics. See specifications for allowable voltage ranges. If the voltage is correct, call SymCom at (800) 843-8848 or (605) 348-5580.
Red light is on steady	<b>RED</b>	The voltage is too low. Measure the line voltage. If the voltage is 7% or more below the nominal voltage as selected by the LINE VOLTAGE ADJUST, the MotorSaver <sup>®</sup> is functioning properly. If the voltage is within 7%, call SymCom at (800) 843-8848 or (605) 348-5580.
Green light blinks and motor is not running	 <b>GREEN</b>	The MotorSaver <sup>®</sup> is timing through the restart delay and will energize its contacts when finished.
Green light is on steady, but motor does not start	<b>GREEN</b>	The MotorSaver <sup>®</sup> is in run mode. Ensure other control devices are allowing the motor to start. Check control circuit for loose wires or malfunctioning switches.

## DIMENSIONS

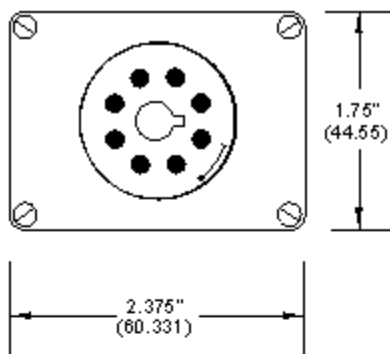

**BOTTOM**

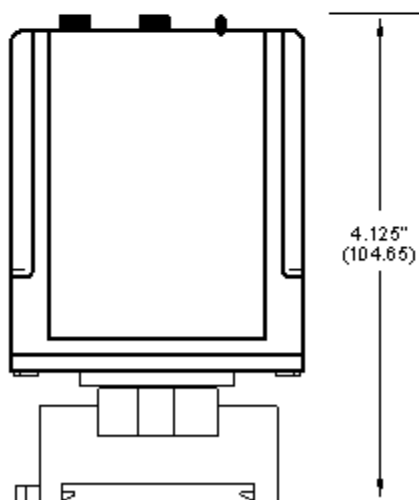

**SIDE  
WITH OT08\* SOCKET**

\*The OT08 octal socket is 35mm DIN rail compatible. The use of OT08 octal sockets is required for Model 201-XXX-SP-DPDT to qualify as UL Listed devices.

# MOTOR SAVER® 201-XXX-SP-DPDT SPECIFICATIONS

<b>Functional Specifications</b>	
Adjustments/Settings	
Low Voltage (% of setpoint)	
Trip	90%±1%
Reset	93%±1%
Trip Delay Times	
Low voltage	4 seconds
Restart Delay Times	
After a fault	2 seconds
After a complete power loss	2 seconds
<b>Input Characteristics</b>	
Line Supply Voltage	
201-100-SP-DPDT	95-120VAC
201-200-SP-DPDT	190-240VAC
Frequency	50 <sup>2</sup> /60 Hz
<b>Output Characteristics</b>	
Output Contact Rating – DPDT	
Pilot Duty	480VA @ 240VAC
General Purpose	10A @ 240VAC
<b>General Characteristics</b>	
Environmental	
Ambient Operating Temperature <sup>3</sup>	-40° to 70°C (-40° to 158°F)
Relative Humidity	10-95%, non-condensing per IEC 68-2-3
Maximum Input Power	5 W
Standards Passed	
Electrostatic Discharge (ESD)	IEC 61000-4-2, Level 3, 6kV contact, 8kV air
Radio Frequency Immunity, Radiated	150 MHz, 10V/m
Fast Transient Burst	IEC 61000-4-4, Level 3, 3.5kV input power and controls
Surge Immunity	
IEC	IEC 61000-4-5, Level 3, 4kV line-to-line; Level 4, 4kV line-to-ground
ANSI/IEEE	C62.41 Surge and Ring Wave Compliance to a level of 6kV line-to-line
Hi-Potential Test	Meets UL508 (2 x rated V +1000V for 1 minute)
Safety Marks	
UL listed (OT08 octal socket required)	UL508 (File #E68520)
CE	IEC 60947-6-2
Dimensions	1.750" H x 2.375" W x 4.125" D (with socket)
Weight	9 oz.
Enclosure	Polycarbonate
Mounting Methods	Plugs into 8-Pin OT08 Socket
Wire Gauge	12-22 AWG Solid or Stranded
Terminal Torque	12 in. - lb.

<sup>2</sup> 50 Hz will increase all delay times by 20%.

<sup>3</sup> The ambient air temperature is the air temperature directly surrounding the product.

For warranty information, please see **Terms and Conditions** at  
[www.symcom.com](http://www.symcom.com)

*Visit us at [www.symcom.com](http://www.symcom.com) to see  
our complete product listing!*

*Need something special?*

*Contact SymCom today  
for your custom solution!  
800-843-8848*