

# INSTALLATION INSTRUCTIONS

Revision A1  
Rapid City, SD, USA, 01/2010

**Motorsaver**<sup>®</sup>  
ELECTRONIC MOTOR  
CONTROL & PROTECTION

## MODELS 201A 201A-9



## **DANGER!**



**HAZARDOUS VOLTAGES MAY BE PRESENT DURING INSTALLATION.**

**Electrical shock can cause death or serious injury.**

**Installation should be done by qualified personnel following all national, state and local electrical codes.**



**BE SURE POWER IS DISCONNECTED PRIOR TO INSTALLATION!  
FOLLOW NATIONAL, STATE AND LOCAL CODES.  
READ THESE INSTRUCTIONS ENTIRELY BEFORE INSTALLATION.**

---

SymCom's MotorSaver<sup>®</sup> Model 201A is an auto ranging plug-in voltage / phase monitor designed to protect 3-phase motors regardless of size. It is used on 190-480 VAC, 50/60 Hz motors to prevent damage caused by single-phasing, low voltage, phase reversal, or voltage unbalance conditions (high voltage detection is only available with the Model 201A-9).

### **CONNECTIONS**

1. Locate a convenient location in or near the motor control panel. If the location is wet or dusty, the MotorSaver<sup>®</sup> should be mounted in a NEMA 4 or 12 enclosure.
2. Mount an 8-pin socket to the motor control back panel (SymCom P/N OT08-PC, sold separately, is required for UL rating).
3. Connect L1, L2 and L3 (terminals 3, 4 & 5 on the relay socket) to the LINE SIDE of the motor starter as shown in Figure 1.
4. Connect the output relay to the circuitry to be controlled. For motor control, connect the normally open contact in series with the magnetic coil of the motor starter as shown in Figure 1. For alarm operation, connect the normally closed contact in series with the control circuit as shown in Figure 2.
5. Plug the MotorSaver<sup>®</sup> into the socket.

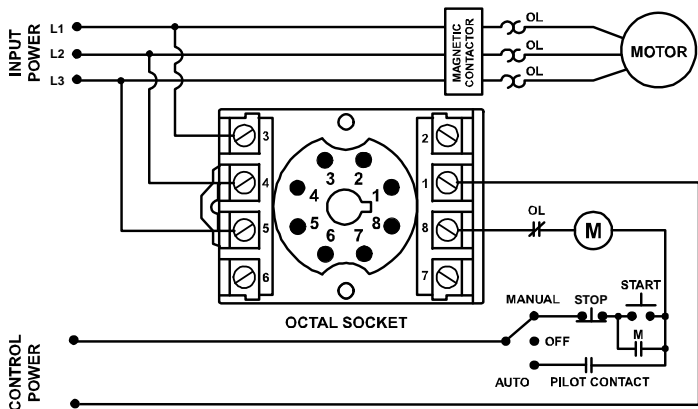

Figure 1: Typical Wiring Diagram

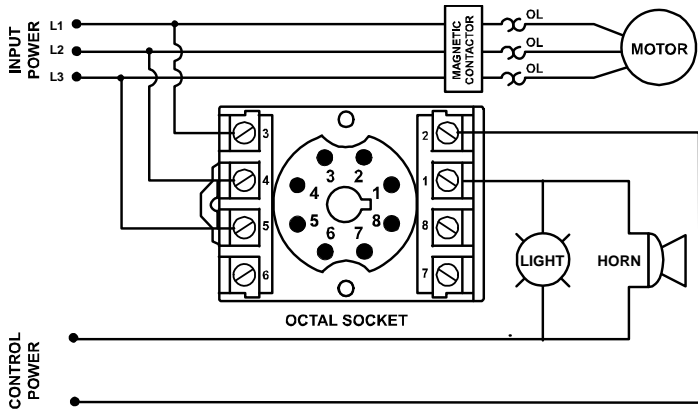

Figure 2: Alarm/Horn Wiring Diagram





## SETTINGS

Rotate the LINE VOLTAGE ADJUSTMENT to the nominal 3-phase line voltage feeding the motor to be protected.

## OPERATION

After applying power to the MotorSaver<sup>®</sup>, the green RUN light will blink during the restart delay. After the restart delay time has expired, the MotorSaver<sup>®</sup> will energize its output contacts (open the normally closed and close the normally open contacts) and the RUN light will turn solid green.

If the contacts do not energize and the RUN light does not turn solid green, see the TROUBLESHOOTING section.

INDICATOR LIGHT	STATUS
GREEN	RUN
 GREEN	RESTART DELAY
 RED	REVERSE PHASE
 RED	UNBALANCE / SINGLE PHASE (SEE EXAMPLE BELOW)
RED	LOW VOLTAGE
 RED	HIGH VOLTAGE (201A-9 ONLY)

**Table 1: Diagnostic Indicator Lights**

### Calculating Voltage Unbalance

NEMA MG1 Unbalance Formula

$$\% \text{ Voltage Unbalance} = \frac{\text{Maximum Deviation from the Average}}{\text{Average}} \times 100\%$$

EXAMPLE: The measured line-to-line voltages are 460, 466, and 490.

$$\text{Average} = \frac{(460 + 466 + 490)}{3} = 472$$





The maximum deviation from the average is the largest difference between the average voltage (472) and any one line-to-line voltage.

$$472 - 460 = 12 \quad 472 - 466 = 6 \quad 490 - 472 = 18$$

The maximum deviation from the average is 18.

$$\% \text{ voltage unbalance} = \frac{18}{472} \times 100 = 3.8\%$$

## TROUBLESHOOTING

SYMPTOM	LIGHT PATTERN	SOLUTION
No lights are on - the unit seems completely dead	N/A	Verify L1, L2 & L3 are connected to terminals 3, 4 & 5. Measure the three line-to-line voltages. If any of the voltages are below 150VAC, the MotorSaver <sup>®</sup> does not have enough power to operate its internal electronics. If the voltages are correct, call SymCom at (800) 843-8848 or (605) 348-5580.
Red light is blinking (on initial power-up)	 RED	Turn off the 3-phase power. Swap any two leads powering the MotorSaver <sup>®</sup> (L1, L2, or L3). There is a 50-50 chance of connecting L1, L2 and L3 correctly the first time. Reapply 3-phase power.
Red light is blinking (after the motor has been running)	 RED	The incoming lines have been reverse-phased. The MotorSaver <sup>®</sup> is preventing the motor from running backwards. Correct the phase sequence.
Red light is blinking in this pattern	 RED	The voltage is unbalanced or single-phased. Measure the incoming line voltages and calculate the % unbalance according to the procedure outlined earlier in this document. If the voltage unbalance does not exceed the % unbalance reset value, call SymCom at (800) 843-8848 or (605) 348-5580.
Red light is blinking in this pattern (201A-9 ONLY)	 RED	The voltage is high. Measure the three line-to-line voltages. If the average voltage is 7% above the line voltage adjustment setting, the MotorSaver <sup>®</sup> is functioning properly. If the voltage is within 7%, call SymCom at (800) 843-8848 or (605) 348-5580.
Red light is on steady	RED	The voltage is low. Measure the three line-to-line voltages. If the average is 7% below the line voltage adjustment setting, the MotorSaver <sup>®</sup> is functioning properly. If the voltage is within 7%, call SymCom at (800) 843-8848 or (605) 348-5580.
Green light blinks and motor is not running	 GREEN	The MotorSaver <sup>®</sup> is timing through the restart delay and will energize its contacts when finished
Green light is on steady, but motor does not start	GREEN	The MotorSaver <sup>®</sup> is in run mode. Ensure other control devices are allowing the motor to start. Check control circuit for loose wires or malfunctioning switches.

## DIMENSIONS

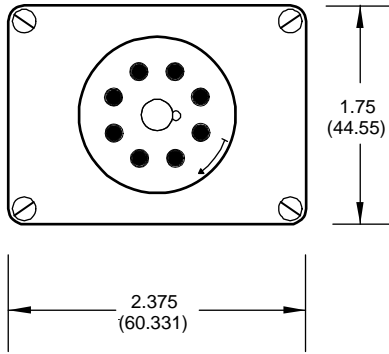

**BOTTOM**

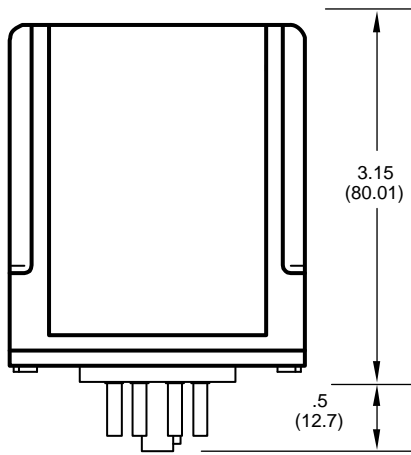

**SIDE**

**NOTE:** Use of the OT08-PC or RB08-PC octal socket, manufactured by Custom Connector Corp., is required for the MotorSaver to qualify as a UL Listed device. The OT08-PC is 35mm DIN rail compatible.

**MOTORSAVER® 201A SPECIFICATIONS**

<b>Functional Characteristics</b>	
Low Voltage	
Trip	90% of setting
Reset	93% of setting
High Voltage (201A-9 only)	
Trip	110% of setting
Reset	107% of setting
Voltage Unbalance	
Trip	6%
Reset	4.5%
Trip Delay	
High/Low Voltage and Unbalance	4 seconds
Single-Phasing	2 seconds
Restart Delay	2 seconds
<b>Input Characteristics</b>	
Line Supply Voltage	190 to 480 VAC
Frequency	50/60Hz
<b>Output Characteristics</b>	
Output Contact Rating	
Pilot Duty	480VA @ 240VAC
General Purpose	10A @ 240VAC
<b>General Characteristics</b>	
Environmental	
Ambient Operating Temperature <sup>1</sup>	-40° to 70°C (-40° to 158°F)
Relative Humidity	10-95%, non-condensing per IEC 68-2-3
Maximum Input Power	5 W
Standards Passed	
Electrostatic Discharge (ESD)	IEC 61000-4-2, Level 3, 6kV contact, 8kV air
Radio Frequency Immunity, Radiated	150 MHz, 10V/m
Fast Transient Burst	IEC 61000-4-4, Level 4, 4kV input power and controls
Surge Immunity	
IEC	IEC 61000-4-5, Level 4, 4kV line-to-line; Level 4, 4kV line-to-ground
ANSI/IEEE	C62.41 Surge and Ring Wave Compliance to a level of 6kV line-to-line
Hi-Potential Test	Meets UL508 (2 x rated V +1000 V for 1 minute)
Safety Marks	
UL listed (OT08 octal socket required)	UL508 (File #E68520)
CE	IEC 60947-6-2
Dimensions	1.750" H x 2.375" W x 4.125" D (with socket)
Weight	9 oz.
Enclosure	Polycarbonate
Mounting Method	Plugs into OT08 Socket
Wire Gauge	12-22 AWG Solid or Stranded
Terminal Torque for P/N OT08 Socket	12 in. - lb

<sup>1</sup> The ambient air temperature is the air temperature directly surrounding the product.

For warranty information, please see **Terms and Conditions** at  
[www.symcom.com](http://www.symcom.com)

*Visit us at [www.symcom.com](http://www.symcom.com) to see  
our complete product listing!*

*Need something special?*

*Contact SymCom today  
for your custom solution!  
800-843-8848*