

# **TRIPLETT**

## **Model 9007**

### **Digital Multimeter Instruction Manual**



 **TRIPLETT**

84-885  
3-10

## Table of Contents

1. Introduction	6. Front Panel
2. Safety Rules and Warnings	7. Measurement Procedures
3. International Symbols	8. Test Lead Holders and Stand
4. Product Features	9. Maintenance
5. Specifications	10. Accessories

### 1: INTRODUCTION

The Triplett 9007 is a ruggedized 3 ½ digit (2000 count) high performance precision digital multimeter with a large backlit high contrast LCD display. Its offering of measurement features includes AC and DC Voltage and Current, Resistance, Continuity, Diode Test, and Capacitance. The overmolded housing provides impact and drop resistance in a sleek ergonomic package, and the convenient Auto Power Off feature maximizes battery life. Its industry leading CAT IV design provides superior resistance to damage from transient overvoltages such as those experienced in demanding industrial settings. The 9007 is well suited for use in all test environments, from occasional use in residential applications, to everyday use by installers, home theater technicians, security technicians, electricians, HVAC technicians, and other professionals in the electrical and electronics industry.



## **2: SAFETY RULES & WARNINGS**

- 2.1 Read all instructions in this manual before using this meter. Failure to do so may result in damage to the meter or injury to the user.
- 2.2 Prior to using the meter in any situation which could result in injury to the user, in order to verify that the meter is functional and producing a valid reading, test the meter on a circuit(s) known to have potentials equivalent to the potential that is to be measured. For example, before using the meter to determine if an AC power line is energized with 120VAC, test the meter on a line known to be energized with 120VAC. Failure to do so may result in damage to the meter or injury to the user.
- 2.3 Do not use this meter with its case open, or with parts removed. Doing so may damage the meter and/or injure the user.
- 2.4 When using this meter in schools and workshops, responsible teachers or skilled personnel must control the usage of this meter. Failure to observe this precaution may result in damage to the meter or injury to the user.

- 2.5 Follow the recommendations of any Trade Organizations or Regulatory Agencies whose scope encompasses the use of this meter. Failure to do so may result in damage to the meter or injury to the user.
- 2.6 Do not open this meter for maintenance without first disconnecting the test leads from all external circuitry. Failure to observe this precaution may result in damage to the meter or injury to the user.
- 2.7 Repairs and maintenance must only be carried out by qualified service personnel or qualified electricians / technicians who know the dangers of, and the safety rules applicable to this type of equipment. Failure to observe this precaution may result in damage to the meter or injury to the user.
- 2.8 Always set the meter to the appropriate range or mode before connecting it to the circuitry to be tested. Failure to observe this precaution may result in damage to the meter or injury to the user.
- 2.9 Check the condition of the test leads before making a measurement. Do not use the test leads if there is damaged insulation or exposed metal. Failure to observe this

precaution may result in damage to the meter or injury to the user.

- 2.10 Make sure test leads are properly inserted and seated in the meter's input jacks. A loose test lead may cause the user to believe that no hazard exists, when in fact, dangerous voltages or currents may be present. Failure to observe this precaution may result in damage to the meter or injury to the user.
- 2.11 Do not touch the tips of the test leads when making a measurement. Do not touch live circuitry when making a measurement. Failure to observe this precaution may result in damage to the meter or injury to the user.
- 2.12 Before using the meter, examine both the meter and the test leads for damage. Do not use the meter if damage (damaged insulation, exposed metal, cracked case, burnt smell, etc.) is evident. Failure to observe this precaution may result in damage to the meter or injury to the user.
- 2.13 Insert the test leads in the jacks specified in the instructions for performing particular tests. Inserting the test leads in incorrect jacks can damage the meter and/or injure the user.

- 2.14 Do not exceed the maximum voltage or current limitations of the meter (see product specifications). Doing so may damage the meter and/or injure the user.
- 2.15 Do not apply voltage or current to the input of the meter when it is set to any of the Ohms  $\Omega$  ranges. Doing so may damage the meter and/or injure the user.
- 2.16 Do not apply voltage or current to the input of the meter when it is set to the Diode Test  or Continuity Beeper  modes. Doing so may damage the meter and/or injure the user.
- 2.17 Do not attempt to measure a voltage source with the test leads plugged into the meter's uAmA or 20A jacks. Doing so may damage the meter and/or injure the user.
- 2.18 Do not rotate the Function switch with the test leads connected to the circuitry to be tested. Doing so may damage the meter or the circuitry, and/or injure the user.
- 2.19 Replace fuses only with exact or equivalent fuses. Do not “bridge” fuses out of circuit. Failure to observe this precaution may result in damage to the meter or injury to the user.

- 2.20 Do not apply voltages to the input of the meter which are elevated above the earth ground potential by more than 600V AC/DC. Doing so may damage the meter and/or injure the user.
- 2.21 Do not continue to use meter when the “low battery” symbol  is displayed. The displayed reading may be in error and lead the user to believe that no hazard exists, when in fact, dangerous voltages or currents may be present. Failure to observe this precaution may result in damage to the meter or injury to the user.
- 2.22 Use caution when working with voltages above 25 volts AC or 35 volts DC. Such voltages may cause a life threatening electrical shock.
- 2.23 This meter is not for use by children. Failure to observe this precaution may result in damage to the meter or injury to the user.
- 2.24 Do not use this meter to make measurements in adverse environments such as rain, snow, fog, or locations with steam, explosive gases or dusts. Doing so may damage the meter and/or injure the user.

- 2.25 Do not use meter in condensing atmospheres. That is, do not use meter in conditions where ambient temperature and humidity could cause condensation of water inside of meter. Doing so may cause injury to the user.
- 2.26 Do not use the meter if either the meter or the test leads are wet, either from exposure to the weather, or after cleaning the case of the meter. Doing so may cause injury to the user.
- 2.27 Do not attempt immediate use of the meter when bringing it from a cold environment to a warm environment. Condensation of water, inside and outside of the meter, may produce dangerous measuring conditions. Allow the meter to warm to room temperature before using. Failure to observe this precaution may result in damage to the meter or injury to the user.
- 2.28 Do not modify the meter. Changing the design may make the meter unsafe and may result in injury to the user.
- 2.29 Use caution when attempting to evaluate if a dangerous voltage is present. The meter will not read AC voltage if it is set to DC, nor will it read DC if it is set to AC. For example, if the meter is set to 200VDC, it will not measure a dangerous AC voltage, even if the probes are



inserted into a household AC wall outlet.

- 2.30 Do not touch the metallic portion of one test lead if the other test lead is connected to a live circuit. The current from the live circuit may pass through the meter and appear on the unconnected test lead. Failure to observe this warning may result in user injury.
- 2.31 Do not attempt to use meter when no display is present on LCD. Doing so may damage the meter and/or injure the user.
- 2.32 Use caution when measuring circuits containing capacitors. Capacitors can store dangerous or lethal levels of electricity, even when the circuitry which they are in has been disconnected from its power source. Some capacitors could source enough energy to damage the meter and/or injure the user.
- 2.33 Do not use the meter if there is evidence of chemical leakage from the battery. Leakage could damage meter and lead to injury of user.

- 2.34 Do not use this meter to measure current in circuits whose open circuit voltage exceeds 250V AC/DC. The meter's fuses are rated at 250V max. Failure to observe this precaution may result in damage to the meter or injury to the user.
- 2.35 When you use the meter to check a high-voltage circuit, do not try to connect both test leads at once. Instead, clip one probe to the neutral or ground lead of the circuit (usually a bare, green, or white wire in AC wiring circuits) using the insulated slip-on Alligator Clips. Then probe for voltages with the other test lead. This helps prevent you from accidentally touching a hot wire, since you need to concentrate on only one test lead. Failure to observe this precaution may result in damage to the meter or injury to the user.
- 2.36 If there is any doubt about the condition of the meter (i.e. safe vs unsafe), remove the meter from service and secure it in a location that will prevent its unintentional use. Failure to observe this precaution may result in damage to the meter or injury to the user.

- 2.37 Do not use the meter if it does not appear to work correctly on all ranges and in all modes. Failure to observe this precaution may result in damage to the meter or injury to the user.
- 2.38 Do not use the meter if it has undergone long-term storage under unfavorable conditions. Failure to observe this precaution may result in damage to the meter or injury to the user.
- 2.39 Do not use the meter if it may have been damaged in transport. Failure to observe this precaution may result in damage to the meter or injury to the user.
- 2.40 Always connect one of the meter's alligator clips to the low side of a power circuit first. Never clamp onto a hot wire first, (usually red, black, or blue in AC wiring circuits.) If you clamp onto a hot wire first, and touch the other probe, you could receive a shock. Failure to observe this precaution may result in damage to the meter or injury to the user.

- 2.41 To avoid damage to the meter and possible user injury, disconnect test leads from test points before changing the function/range. Failure to observe this precaution may result in damage to the meter or injury to the user.
- 2.42 Avoid usage near strong magnetic fields (magnets, loudspeakers, transformers, motors, coils, relays, contactors, electromagnets, etc.). The meter may display readings that are in error, causing the user to misinterpret the hazards present. For example, the meter may indicate a low voltage when high voltages are actually present. Failure to observe this precaution may result in damage to the meter or injury to the user.
- 2.43 Avoid usage near strong electrostatic fields (high voltage power lines, televisions, computer monitors, etc.). The meter may display readings that are in error, causing the user to misinterpret the hazards present. For example, the meter may indicate a low voltage when high voltages are actually present. Failure to observe this precaution may result in damage to the meter or injury to the user.

- 2.44 Avoid usage near strong RF fields (radio or television transmitters, walkie talkies, cellular phones, etc.). The meter may display readings that are in error, causing the user to misinterpret the hazards present. For example, the meter may indicate a low voltage when high voltages are actually present. Failure to observe this precaution may result in damage to the meter or injury to the user.
- 2.45 Remove the battery when the meter may be left unused for longer than 1 month. Chemical leakage from the battery could damage the meter, leading to user injury.
- 2.46 Do not attempt to test charged capacitors. Only discharged capacitors may be tested. If you wish to test a capacitor, discharge it using an approved method before connecting it to the meter. **Caution:** Some capacitors can store dangerous lethal charges. Discharging these capacitors can be dangerous unless an approved method is used. Failure to observe this precaution may result in damage to the meter or injury to the user.

### 3: INTERNATIONAL SYMBOLS

The following International Symbols may be used in this manual and on the case of the meter to identify, caution, or warn the user of important product limitations or important operational procedures that must be followed to ensure safe usage of the product.



**Low Battery**



**Ground**



**See Instruction Manual**



**AC**



**DC**



**Fuse**



**Double Insulated**



**Beeper**



**Diode**



**AC or DC**



**Dangerous Voltages**

## **4: PRODUCT FEATURES**

- 4.1 31 Measurement Ranges
- 4.2 Huge 1.4" tall High Contrast LCD display
- 4.3 White LCD Backlight allows viewing in poorly lit areas
- 4.4 3 1/2 digit resolution (2000 counts)
- 4.5 Protective shock absorbing overmolded shell with built in stand and test lead holders
- 4.6 Diode Test
- 4.7 Continuity Beeper
- 4.8 Capacitance Test
- 4.9 Auto Power Off
- 4.10 Fused mA and Amp ranges
- 4.11 Overload protection
- 4.12 Double Insulated
- 4.13 CE Mark (EMC / LVD)
- 4.14 CAT I, II, III, and IV compliance (see Specifications for details)

## 5: SPECIFICATIONS

- 5.1 Display: .....1.4" (35mm) high LCD
- 5.2 Display Resolution: .....2000 counts, 0000 to 1999
- 5.3 Overrange Indication: .....First digit displays "1", remaining digits are blank
- 5.4 Measurement Rate: .....2 times per second
- 5.5 Low Battery Annunciator: .. 
- 5.6 Operating Conditions:  
Temperature: .....0 to 50 degrees C  
(32 to 122 degrees F)  
Relative Humidity:.....less than 70%
- 5.7 Storage Conditions:  
Temperature: .....-20 to 60 degrees C  
(-4 to 140 degrees F)  
Relative Humidity.....less than 80%
- 5.8 Case Dimensions: .....17.8 x 8.2 x 5.6 cm, (L x W x H)  
7 x 3.2 x 2.2 inches (L x W x H)
- 5.9 Weight (w battery) .....Approx 400 grams, 0.88 lbs.
- 5.10 Battery: .....1 standard 9 volt alkaline battery  
NEDA 1604, Triplett Part No. 37-48
- 5.11 Battery Life: .....Typically 200 hours
- 5.12 Fuses: .....0.2A / 250 volt FAST, 5 x 20mm  
fuse, for mA ranges. Triplett  
Part No. 3207-133



## 5: SPECIFICATIONS CONT.

20A / 250 volt FAST, 6 x 25mm, for  
20A range. Triplet Part No. 3207-134

5.13 Insulation: .....Double Insulated (Protection Class II)

5.14 Pollution Degree .....2

5.15 Approvals: .....IEC 1010-1 (EN61010-1)  
Overvoltage Category  
(Installation Category)  
Category I to 1000 volts DC,  
700 volts AC  
Category II to 1000 volts DC,  
700 volts AC  
Category III to 1000 volts DC,  
700 volts AC  
Category IV to 600 volts AC/DC  
CE: EMC, LVD

*Note:*

- a) *The following accuracy specifications are valid at 23 degrees C, +/- 5 degrees C, Relative Humidity less than 75%*
- b) *The specifications are in the form “ +/- (x % of reading + LSD)” where LSD is “Least Significant Digit”.*

<b>DC Voltage</b>		
Range	Resolution	Accuracy
200.0mV	0.1mV	± (0.5% rdg + 2 digit)
2.000V	1mV	
20.00V	10mV	
200.0V	100mV	
1000V	1V	± (0.8% rdg + 2 digit)

 **Input Impedance:** All ranges are 10MΩ  
**Overload Protection:** 200mV Range: 250V AC/DC rms.  
Other VDC ranges: 1000VDC, 700VAC rms

<b>AC Voltage</b>		
Range	Resolution	Accuracy
200.0mV	0.1mV	± (1.0% rdg + 5 digits)
2.000V	1mV	± (1.0% rdg + 3 digits)
20.00V	10mV	
200.0V	100mV	
700V	1V	± (1.2% rdg + 5 digits)



**Input Impedance:** All ranges are 10M $\Omega$

**Frequency:** 50Hz to 400Hz

**Overload Protection:** 200mV Range: 250V AC/DC rms.  
Other VAC ranges: 1000VDC, 700VAC rms

**Display:** Average Value (RMS of Sine Wave)

<b>DC Current</b>		
Range	Resolution	Accuracy
2.000mA	1 $\mu$ A	±(1.0% rdg + 3 digits)
20.00mA	10 $\mu$ A	± (1.5% rdg + 3 digits)
200.0mA	100 $\mu$ A	
20.00A	10mA	± (2.5% rdg + 10 digits)



**Overload Protection:** 0.2A / 250V fuse  
(below 200mA range)  
20A /250V fuse (20A range)

Limit measurement time on 20A range to 30 seconds  
for inputs over 10A. Allow 15 minutes cool down  
between measurements.

<b>AC Current</b>		
Range	Resolution	Accuracy
2.000mA	1 $\mu$ A	$\pm$ (1.2% rdg + 3 digits)
200.0mA	100 $\mu$ A	$\pm$ (2.0% rdg + 3 digits)
20.00A	10mA	$\pm$ (3% rdg + 10 digits)



**Overload Protection:** 0.2A / 250V fuse  
 (below 200mA range)  
 20A /250V fuse (20A range)  
 Limit measurement time on 20A range to 30 seconds  
 for inputs over 10A. Allow 15 minutes cool down  
 between measurements.  
**Display:** Average Value (RMS of Sine Wave)



<b>Resistance</b>		
Range	Resolution	Accuracy
200.0 $\Omega$	0.1 $\Omega$	$\pm$ (1.0% rdg + 4 digits) after subtracting any residual resistance noted when test leads are shorted.
2.000K $\Omega$	1 $\Omega$	$\pm$ (1.0% rdg + 2 digits)
20.00K $\Omega$	10 $\Omega$	$\pm$ (1.2% rdg + 2 digits)
200.0K $\Omega$	100 $\Omega$	
2.000M $\Omega$	1K $\Omega$	
20.00M $\Omega$	10K $\Omega$	$\pm$ (2.0% rdg + 5 digits)
200.0M $\Omega$	100K	$\pm$ [5% (rdg-10) + 10 digits]*

**⚠ Overload Protection:** All ranges 250V DC or AC RMS.

\* On 200M Ohm range, it is normal for the meter to display 10 LSD with the test leads shorted together. To obtain an accurate reading, subtract 10 LSD from the displayed value.

<b>Capacitance</b>		
Range	Resolution	Accuracy
2.000nF	1pF	± (4.0% rdg + 70 digits)
20.00nF	10pF	± (4.0% rdg + 3 digits)
200.0nF	0.1nF	
2.000uF	1nF	
200.0uF	0.1uF	<20uF, ± (5% rdg + 10 digits)
		>20uF, unspecified

**⚠ Overload Protection:** All ranges 250V DC or AC RMS.

<b>Diode Test and Continuity Beeper</b>		
Range	Display	Notes
	Actual diode voltage in volts	Forward DC current about 1mA Open circuit voltage about 2.8V
	Does not display resistance accurately	Beeper sounds if Continuity Resistance is less than 10 to 30 OhmsΩ

**⚠ Overload Protection:** 250V DC or AC RMS.

## 6: FRONT PANEL

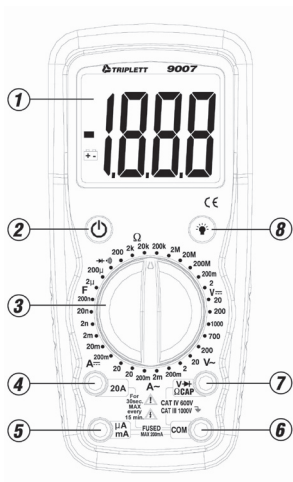

1. LCD Display
2. Power Button
3. Function Switch
4. 20A Input Jack
5. uA and mA Input Jack
6. COM Input Jack
7. Volt, Ohm, Capacitance, Diode Test, and Continuity Input Jack
8. Backlight Button

## 7: MEASUREMENT PROCEDURES

**WARNING!** 

Do not use the meter when the low battery symbol  is displayed. This may cause the meter to produce inaccurate readings, and lead the user to believe that no hazard exists, when, in fact, dangerous voltages or currents are present.

### 7.1 LCD Backlight

The 9005-A incorporates a convenient LCD Backlight. The Backlight provides illumination for the LCD in dimly lit conditions. When the blue  button is pressed, the white LED Backlight will turn on for about 5 seconds, and then automatically turn off.

### 7.2 Power Button and Auto Power Off:

Turn on the 9007 by pressing the yellow power button . Press it again to turn the meter off.

The 9007 has Auto Power Off. This feature automatically turns the meter off 10 to 15 minutes after it was turned on..... thereby extending battery life.

### 7.3 DC Voltage Measurement:

**WARNING!** 



If the magnitude of the voltage to be measured is unknown, always start by setting the meter to the highest range, and then to lower ranges, until a satisfactory reading is obtained.

*Do not rotate the RANGE switch with the input applied to the meter.*

If the input voltage is higher than 1000VDC (CAT I, CAT II, or CAT III), or 600V DC (CAT IV), do not attempt to measure!



**Use Caution when measuring voltages above 50V DC.**

- 7.3.1 Connect the black test lead to the **COM** jack and the red test lead to the **VOLT / DIODE / OHM / CAP** “V   $\Omega$  CAP” jack.
- 7.3.2 Set the RANGE switch to a V  position. If the magnitude of the voltage is unknown, set the RANGE switch to the highest V  position. If the input voltage is higher than the previously stated limits, do not attempt to measure!
- 7.3.3 Connect the test probes to circuit being measured. The LCD will display the DC voltage.



- 7.3.4 If the display indicates overrange, i.e. “1- - -”, disconnect the test probes from the circuit and rotate the RANGE switch to the next higher position. Reconnect the test probes to the circuit and observe the reading on the LCD display. If the RANGE switch is already at the highest position (i.e. 1000 VDC), the input voltage exceeds the measurement capability of the meter and should not be measured.
- 7.3.5 If the displayed value is less than “200” (decimal point not shown), a more accurate reading may be obtained by setting the RANGE switch to a lower range. Disconnect the probes from the circuit and rotate the RANGE switch to the next lower position. Reconnect the test probes to the circuit and observe the reading on the LCD display. If the RANGE switch is already on the lowest position (i.e. 200m VDC), no greater measurement resolution can be obtained.

## 7.4 AC Voltage Measurement:

### **WARNING!**

If the magnitude of the voltage to be measured is unknown, always start by setting the meter to the highest range, and then to lower ranges, until a satisfactory reading is obtained.

*Do not rotate the RANGE switch with the input applied to the meter.*

If the input voltage is higher than 700VAC (CAT I, CAT II, CAT III), or 600VAC (CAT IV), do not attempt to measure!



**Use Caution when measuring voltages above 30V AC.**

- 7.4.1 Connect the black test lead to the **COM** jack and the red test lead to the **VOLT / DIODE / OHM / CAP** “**V**  **Ω CAP**” jack.
- 7.4.2 Set the RANGE switch to a **V~** position. If the magnitude of voltage is unknown, set the RANGE switch to the highest **V~** position. If the input voltage is higher than the previously stated limits, do not attempt to measure!
- 7.4.3 Connect the test probes to circuit being measured. The LCD will display the AC voltage.

- 7.4.4 If the display indicates overrange, i.e. “1 - -”, disconnect the test probes from the circuit and rotate the RANGE switch to the next higher position. Reconnect the test probes to the circuit LCD display. If the RANGE switch is already at the highest position (i.e. 700 VAC), the input voltage exceeds the measurement capability of the meter and should not be measured.
- 7.4.5 If the displayed value is less than “200” (decimal point not shown), a more accurate reading may be obtained by setting the RANGE switch to a lower range. Disconnect the probes from the circuit and rotate the RANGE switch to the next lower position. Reconnect the test probes to the circuit and observe the reading on the LCD display. If the RANGE switch is already on the lowest position (i.e. 200m AC), no greater measurement resolution can be obtained.

## 7.5 DC Current Measurement:

### **WARNING!**

If the magnitude of the current to be measured is unknown, always start by setting the meter to the highest range, and then to lower ranges, until a satisfactory reading is obtained.

*Do not rotate the RANGE switch with the input applied to the meter.*  
If the input current is higher than 20A, do not attempt to measure!



Use caution when measuring current in a circuit with voltages above 50 VDC. Do not use meter to measure current in circuits whose voltage exceeds 250V AC/DC.

7.5.1 Connect the black test lead to the **COM** jack. Connect the red test lead to the **20A** jack unless it is known that the input current is less than 200mA. If the current is less than 200mA, connect the red test lead to the **uA mA** jack.

7.5.2 If the red test lead is inserted into the **20A** jack, set the RANGE switch to the **20 A**  position. Connect the test leads **IN SERIES** with the circuit to be measured. Read the value of the current on the LCD display.

- 7.5.3 If the red test lead is inserted into the **uA mA** jack, set the RANGE switch to the **200m A** **===** position. Connect the test leads ***IN SERIES*** with the circuit to be measured. Read the value of the current on the LCD.
- 7.5.4 If the display indicates overrange, i.e. “1- - -”, disconnect the test probes from the circuit and reconnect the red test lead to the **20A** jack. Set the RANGE switch to the **20 A** **===** position, and reconnect the test leads to the circuit. Read the value from the LCD. If the display indicates overrange, i.e. “1- - -”, the input current exceeds the measurement capability of the meter, and should not be measured.
- 7.5.5 If the displayed value is less than “200” (decimal point not shown), a more accurate reading may be obtained by setting the RANGE switch to a lower range. Disconnect the probes from the circuit and rotate the RANGE switch to the next lower position. Reconnect the test probes to the circuit and observe the reading on the LCD display. If the RANGE switch is already on the lowest position (i.e. 2m), no greater measurement resolution can be obtained.

## 7.6 AC Current Measurement:

### **WARNING!**

If the magnitude of the current to be measured is unknown, always start by setting the meter to the highest range, and then to lower ranges, until a satisfactory reading is obtained.

*Do not rotate the RANGE switch with the input applied to the meter.*

If the input current is higher than 20A, do not attempt to measure!



Use caution when measuring current in a circuit with voltages above 30 VAC. Do not use meter to measure current in circuits whose voltage exceeds 250V AC/DC.

- 7.6.1 Connect the black test lead to the **COM** jack. Connect the red test lead to the **20A** jack unless it is known that the input current is less than 200mA. If the current is less than 200mA, connect the red test lead to the **uA mA** jack.
- 7.6.2 If the red test lead is inserted into the **20A** jack, set the RANGE switch to the **20 A~** position. Connect the test leads **IN SERIES** with the circuit to be measured. Read the value of the current on the LCD display.

- 7.6.3 If the red test lead is inserted into the **uA mA** jack, set the RANGE switch to the **200m A~** position. Connect the test leads IN SERIES with the circuit to be measured. Read the value of the current on the LCD.
- 7.6.4 If the display indicates overrange, i.e. “1- -”, disconnect the test probes from the circuit and reconnect the red test lead to the **20A** jack. Set the RANGE switch to the **20 A ~** position, and reconnect the test leads to the circuit. Read the value from the LCD. If the display indicates overrange, i.e. “1- -”, the input current exceeds the measurement capability of the meter, and should not be measured.
- 7.6.5 If the displayed value is less than “200” (decimal point not shown), a more accurate reading may be obtained by setting the RANGE switch to a lower range. Disconnect the probes from the circuit and rotate the RANGE switch to the next lower position. Reconnect the test probes to the circuit and observe the reading on the LCD display. If the RANGE switch is already on the lowest position (i.e. 2m), no greater measurement resolution can be obtained.

## 7.7 Resistance Measurement:

**WARNING!** 

**Do not apply voltage or current to the meter when it is set to any of the “ $\Omega$ ” ranges.**

- 7.7.1 Connect the black test lead to the COM jack, and the red test lead to the **VOLT / DIODE / OHM / CAP** “**V**   **$\Omega$  CAP**” jack.
- 7.7.2 Set the RANGE switch to the **Ohms** “ **$\Omega$** ” position that is appropriate for the device or circuit to be measured. The LCD display will indicate overrange (i.e. “1 - -”).
- 7.7.3 Connect the test leads to the device or circuit being measured. Observe correct polarity if appropriate.
- 7.7.4 If the display indicates overrange, i.e. “1- -”, rotate the RANGE switch to the next higher position and observe the reading on the LCD display. If the RANGE switch is already at the highest position (i.e. 200M Ohms), the resistance exceeds the value measurable by the meter.



7.7.5 If the displayed value is less than “200” (decimal point not shown), a more accurate reading may be obtained by setting the RANGE switch to a lower range. Rotate the RANGE switch to the next lower position and observe the reading on the LCD display. If the RANGE switch is already on the lowest position (i.e. 200 Ohms), no greater measurement resolution can be obtained.



*Notes:*

- a) The 2M, 20M, and 200M ranges require several seconds to stabilize.*
- b) The 200M range reads about 10 LSD high. To obtain an accurate reading, short the test leads together and observe the residue reading (usually 8 to 12 LSD). For the best accuracy, subtract observed reading from subsequent measurements.*
- c) To obtain the most accurate reading on the 200 $\Omega$  range, short the test leads together and note the “residual resistance” reading. It is typically less than 0.5 $\Omega$  . Subtract this value from subsequent readings on the 200 $\Omega$  range.*

## 7.8 Continuity Beeper:

**WARNING!** 

**Do not apply voltage or current to the meter when it is set to the Diode Test / Continuity Beeper “” range.**



- 7.8.1 Connect the black test lead to the **COM** jack and the red test lead to the **VOLT / DIODE / OHM / CAP** “**V  Ω CAP**” jack.
- 7.8.2 Set the RANGE switch to the **Diode Test / Continuity Beeper** “****” range.
- 7.8.3 Connect the test probes to the device or circuit to be tested.
- 7.8.4 If the resistance of the device or circuit is less than 20 to 100 Ohms, the continuity beeper will sound.

*Note: The reading displayed on the LCD is not an accurate indication of the resistance of the device or circuit being measured.*

## 7.9 Diode Test:

**WARNING!** 

**Do not apply voltage or current to the meter when it is set to the Diode Test / Continuity Beeper “  ” range**

- 7.9.1 Connect the black test lead to the COM jack and the red test lead to the **VOLT / DIODE / OHM / CAP “V  Ω CAP”** jack.
- 7.9.2 Set the RANGE switch to the Diode Test / Continuity Beeper “  ” range.
- 7.9.3 Connect the test probes to the device or circuit to be tested. To test a simple diode, connect the red test probe to the Anode of the diode and the black test lead to the Cathode (“banded” end) of the diode. The LCD will indicate the voltage drop of the diode. Reverse the connections of the test probes to the diode. The LCD should indicate overrange (“1 - -”). If the Continuity Beeper sounds when the leads are connected in either direction to a standard silicon diode, the diode is probably shorted.

*Note: The reading displayed on the LCD is an accurate indication of the voltage drop of the device or circuit being measured.*

## 7.10 Measuring Capacitance:

### **WARNING!**

Do not apply voltage or current to the meter when it is set to the Capacitance “F” ranges. Do not connect a charged capacitor to the meter. Doing so may damage the meter or injure the user.

- 7.10.1 Connect the black test lead to the COM jack and the red test lead to the **VOLT / DIODE / OHM / CAP** “V  Ω CAP” jack.
- 7.10.2 Set RANGE switch to the **F** position appropriate for the measurement to be made.
- 7.10.3 Connect the test leads to the capacitor to be measured. Observe proper polarity (if appropriate). Read value from the LCD display.
- 7.10.4 If the display indicates overrange, i.e. “1- - -”, rotate the RANGE switch to the next higher position and observe the reading on the LCD display. If the RANGE switch is already at its highest position (i.e. 200u F), and the reading exceeds 20.0, it should be considered inaccurate.

7.10.5 If the displayed value is less than “200” (decimal point not shown), a more accurate reading may be obtained by setting the RANGE switch to a lower range. Rotate the RANGE switch to the next lower position and observe the reading on the LCD display. If the RANGE switch is already on the lowest position (i.e. 2n F), no greater measurement resolution can be obtained.

*Notes:*

- a) *On the 2nF and 20nF ranges, the meter may indicate residual capacitance. i.e The meter reading will not go to zero. This is caused by the internal capacitance of the meter circuitry or the test leads.*
- b) *The Test Leads may introduce error when used on the low capacitance ranges (like 2nF and 20nF). To minimize the error, note the difference in reading with the leads inserted into the meter and with the leads removed from the meter, and when using the test leads, subtract the noted difference from the displayed reading.*

## **8: TEST LEAD HOLDERS STAND, and HANGER**

Test Lead Holders are provided on the back of the 9007. The test leads may be snapped into the back of the meter for storage, or one or both leads may be snapped into the holders with the tip protruding, forming a handy 'meter with probe' unit.

A built in stand can be flipped out to tilt the meter up to a convenient angle for use on a table top.

A recess in the back of the meter allows it to be hung from a hook or nail.

## **9: MAINTENANCE**

Your Triplet Model 9007 DMM is a precision measuring instrument and, when used as described in this manual, should not require maintenance.

However, periodic calibration of the meter will insure that it is accurate and performing in accordance with its design specifications.

A one year calibration interval is suggested.

To clean the outside of the meter, use a cloth dampened with a mild detergent solution. Do not use any abrasive cleansers, or chemical solvents that may damage the case of the meter.

## **9.1 Replacing Battery:**

- 9.1.1 Remove the test leads from the meter.
- 9.1.2 Remove 1 screw from the top of the battery compartment cover. Flip the Stand out and remove the screw from the bottom of the battery compartment cover. The cover is sealed and may fit tightly. A small screwdriver inserted at the top of the cover may help to remove it.
- 9.1.3 Remove the 9 volt battery and, observing proper polarity, replace with a fresh battery (PN 37-48).
- 9.1.4 Reassemble battery compartment cover. Reinstall screws.
- 9.1.5 Verify that the meter operates properly before using it to make measurements.

## **9.2 Replacing Fuses:**

- 9.2.1 Remove the test leads from the meter.
- 9.2.2 Remove the 4 screws from the back of the meter case. Flip up the Stand and remove 2 additional screws. It is not necessary to remove the battery cover screws.



- 9.2.3 Open the meter case by wiggling the back to separate it from the front. Set the back of the case to one side.
- 9.2.4 Locate the defective fuse and replace with the exact or equivalent type. See meter specifications.
- 9.2.5 Reassemble case of meter. Reinstall screws.
- 9.2.6 Verify that the meter operates properly before using it to make measurements.

## **10: ACCESSORIES**

- 10.1 The Triplett Model 9007 package contains the following items:
  - 10.1.1 The Model 9007 DMM
  - 10.1.2 Test leads for the 9007 (Triplett PN 79-808)
  - 10.1.3 Instruction Manual (Triplett PN 84-885)
- 10.2 Several different carrying cases may be used for the 9007. Contact a Triplett representative to obtain help with determining which case will suit your needs.

## **Triplett Product Return Instructions**

In the unlikely event that you must return your Triplett equipment for repair, the following steps must be taken.

- 1) Call 1-800-TRIPLETT to obtain a Return Material Authorization (RMA) number from Customer Service.
- 2) Enclose a copy of the original sales receipt showing date of purchase.
- 3) Clearly print the RMA number on the outside of the shipping container.
- 4) Return to: Triplett / Jewell Instruments  
850 Perimeter Road  
Manchester, NH 03103  
ATTN: Repair Dept.

## **Triplett Three Year Limited Warranty**

Triplett warrants instruments and test equipment manufactured by it to be free from defective material or workmanship and agrees to repair or replace such products which, under normal use and service, disclose the defect to be the fault of our manufacturing, with no charge within three years of the date of original purchase for parts and labor.

If we are unable to repair or replace the product, we will make a refund of the purchase price. Consult the Instruction Manual for instructions regarding the proper use and servicing of instruments and test equipment. Our obligation under this warranty is limited to repairing, replacing, or making refund on any instrument or test equipment which proves to be defective within three years from the date of original purchase.

This warranty does not apply to any of our products which have been repaired or altered by unauthorized persons in any way so as, in our sole judgment, to injure their stability or reliability, or which have been subject to misuse, abuse, misapplication, negligence, accident or which have had the serial numbers altered, defaced, or removed. Accessories, including batteries and fuses, not of our manufacture used with this product are not covered by this warranty.

## **Triplett Three Year Limited Warranty**

To register a claim under the provisions of this warranty, contact Triplett's Customer Service Department for a Return Authorization Number (RMA) and return instructions. No returned product will be accepted without an RMA number. Upon our inspection of the product, we will advise you as to the disposition of your claim.

ALL WARRANTIES IMPLIED BY LAW ARE HEREBY LIMITED TO A PERIOD OF THREE YEARS FROM DATE OF PURCHASE, AND THE PROVISIONS OF THE WARRANTY ARE EXPRESSLY IN LIEU OF ANY OTHER WARRANTIES EXPRESSED OR IMPLIED.

The purchaser agrees to assume all liability for any damages and bodily injury which may result from the use or misuse of the product by the purchaser, his employees, or others, and the remedies provided for in this warranty are expressly in lieu of any other liability Triplett may have, including incidental or consequential damages.

Some states (USA ONLY) do not allow the exclusion or limitation of incidental or consequential damages, so the above limitation or exclusion may not apply to you. No representative of Triplett / Jewell Instruments or any other person is authorized to extend the liability of Triplett in connection with the sale of its products beyond the terms hereof.

## **Triplett Three Year Limited Warranty**

Triplett reserves the right to discontinue models at any time, or change specifications, price or design, without notice and without incurring any obligation.

This warranty gives you specific legal rights, and you may have other rights which vary from state to state.