



1 1/8" Channel

Telestrut

Nuts & Hardware

General Fittings

Pipe/Conduit Supports

Electrical Fittings

Concrete Inserts

Solar

Unipier®

P2348 EG, GR, HG

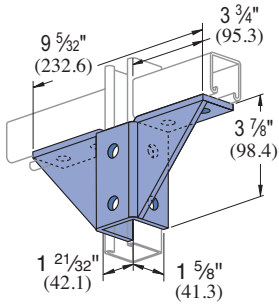

Wt/100 pcs: 274 Lbs (124.3 kg)

P2453 EG, GR, HG

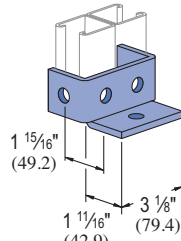

Wt/100 pcs: 116 Lbs (52.6 kg)

P1887 EG, GR, HG

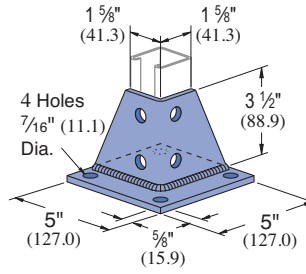

Wt/100 pcs: 297 Lbs (134.8 kg)

P2941, P2942 EG, GR, HG

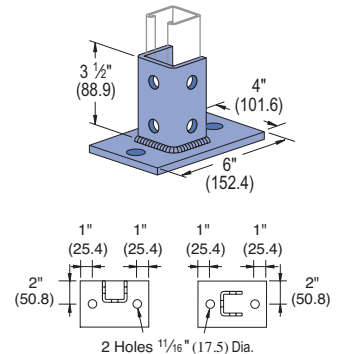

Wt/100 pcs: 358 Lbs (162.4 kg)

P2072, P2072 SQ EG, GR, HG

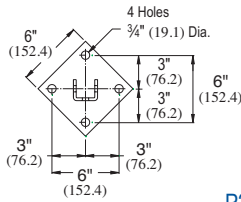
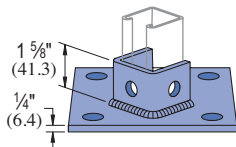

P2072

P2072A, P2072A SQ DF, EG, GR, HG

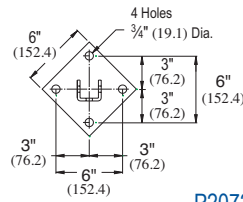
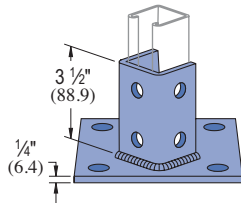

P2072A

P2073, P2073 SQ EG, GR, HG

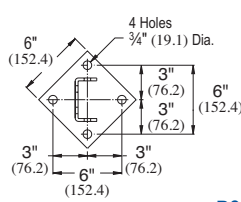
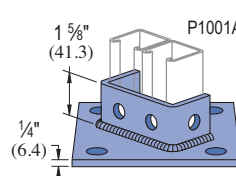

P2073

P2073A, P2073A SQ EG, GR, HG

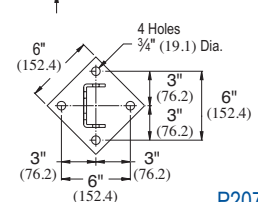
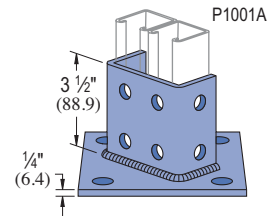

P2073A

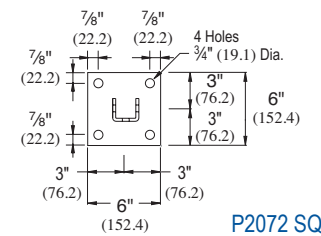

P2072 SQ

Wt/100 pcs: 307 Lbs (139.3 kg)

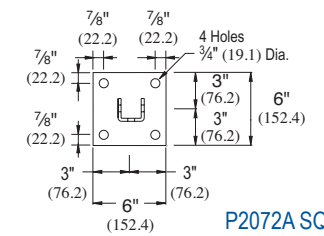

P2072A SQ

Wt/100 pcs: 373 Lbs (169.2 kg)

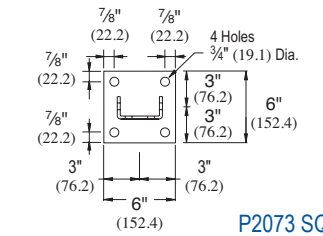

P2073 SQ

Wt/100 pcs: 325 Lbs (147.4 kg)

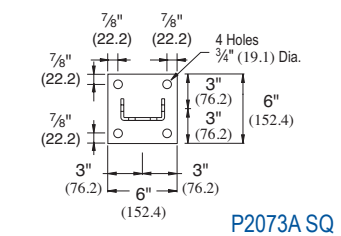

P2073A SQ

Wt/100 pcs: 408 Lbs (185.1 kg)

P1769 EG, GR

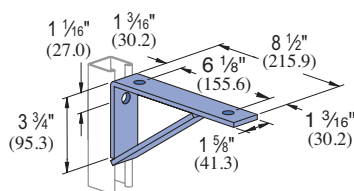

Material: 1/4" (6.4) thick steel.

Wt/100 pcs: 174 Lbs (78.9 kg)

Part No.	Gauge	Vertical Channel	Uniform Design Load
		Lbs (kN)	Lbs (kN)
P1000	12	800	3.56
P1100	14	600	2.67
P2000	16	400	1.81

Safety Factor 2 1/2

P1771 EG, GR

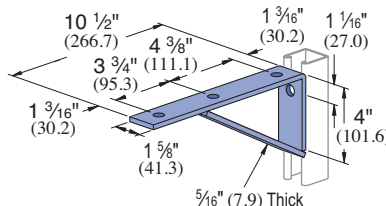

Material: 1/4" (6.4) thick steel.

Wt/100 pcs: 206 Lbs (93.4 kg)

Part No.	Gauge	Vertical Channel	Uniform Design Load
		Lbs (kN)	Lbs (kN)
P1000	12	800	3.56
P1100	14	600	2.67
P2000	16	400	1.81

Safety Factor 2 1/2

Standard Dimensions for 1 1/8" (41.3mm) width series channel fittings (Unless Otherwise Shown on Drawing)

Hole Diameter: 9/16" (14.3mm); Hole Spacing - From End: 1 1/16" (20.6mm); Hole Spacing - On Center: 1 1/8" (47.6mm); Width: 1 1/8" (41.3mm); Thickness: 1/4" (6.4mm) with steel meeting or exceeding ASTM A1011 SS GR 33, or 0.220" (5.6mm) with steel meeting or exceeding ASTM A1011 HSLAS GR 45