

VACON

DRIVEN BY DRIVES



VACON SE2 USER'S MANUAL

Need Help?

This manual answers most installation and startup questions that may arise. However, if you have any problems, please let your first call be to us.

Vacon, Inc.
Chambersburg, PA 17202

Normal business hours:
(North America)

8:00 AM to 5:00 PM, Eastern time
+1 877-Vacon06
(+1 877-822-6606)

After-hours support is also available

**For a quick-start summary of SE2 features, see
[“Appendix A: Quick Start Guide for the SE2 Drive” on page 42](#)**



and Vacon, Inc. are trademarks of Vacon Plc, a member of Vacon Group

SE2 User's Manual: Table of Contents

1	Introduction	5
1.1	Product overview	5
1.2	Important safety information	5
1.3	Electromagnetic compatibility (EMC)	7
1.4	Summary of certifications	7
1.5	User's manual publication history	7
2	About the SE2 drive	8
2.1	Identifying the drive by model number	8
2.2	Drive model numbers	9
3	Receiving and installation	10
3.1	Preliminary inspection	10
3.2	Installation precautions	10
3.3	Mechanical dimensions	11
4	Power wiring	13
4.1	General wiring information	13
4.2	Drive and motor connections	17
4.3	Motor terminal box connections	17
5	Control wiring	18
5.1	Control terminal connections	18
5.2	RJ45 data connection	18
6	Operation	19
6.1	Using the keypad	19
6.2	Changing parameters	19
6.3	Resetting factory default settings	20
6.4	Terminal control	20
6.5	Keypad control	21
7	Parameters	22
7.1	Level 1 parameters	22
7.2	Level 2 parameters	24
7.3	Adjusting Voltage / frequency (V/f) characteristics	28
7.4	P-00 read only drive status parameters (Group Zero)	28
8	Analog and digital input configurations	30
8.1	Terminal mode (P-201=0)	30
8.2	Typical applications for terminal mode	31
8.3	Keypad mode (P-201 = 1 or 2)	34
8.4	Modbus control mode (P-201 = 3 or 4)	35
8.5	User PI control mode (P-201 = 5 or 6)	35

9	Troubleshooting and fault messages	38
10	Technical data	40
	10.1 Environmental information	40
	10.2 Ratings	40
	10.3 Maximum supply ratings for UL compliance	41
	Start-up guide	42

1. INTRODUCTION

1.1 PRODUCT OVERVIEW

Although the Vacon SE2 variable speed AC drive is small in size, it is big on performance. It is an economical yet powerful solution for many industrial applications. It features remote communications capability (using Modbus® protocol), a keypad for easy configuration, and standard NEMA 12 / IP54 enclosures that eliminate the need for mounting in a separate enclosure.

A separate model with a line disconnect speed potentiometer and direction selector switch is also available. Contact your local Vacon distributor for more information.

This product family includes a wide variety of models to suit almost any input voltage requirement. An 'x' in the following table indicates what models are currently available. Refer to [“Identifying the drive by model number” on page 8](#) for help in interpreting model numbers.

		Input Voltage			
Power (kW)	Power (hp)	115 Vac 1 Phase	230 Vac 1 Phase	230 Vac 3 Phase	460 Vac 3 Phase
0.37	0.5	x	x		
0.75	1	x	x		x
1.5	2	x	x	x	x
2.2	3		x	x	x
4.0	5			x	x
5.5	7.5				x
7.5	10				x

1.2 IMPORTANT SAFETY INFORMATION

The SE2 variable speed drive is intended for professional incorporation into complete equipment or systems. If it is installed incorrectly, it may cause a safety hazard. The SE2 uses high voltages and currents, carries a high level of stored electrical energy, and controls mechanical devices that can cause injury. Pay close attention to system design and electrical installation to avoid hazards in either normal operation or in the event of equipment malfunction.

System design, installation, commissioning, and maintenance must be carried out only by personnel who have the necessary training and experience to do it correctly. Please ensure that the safety information and instructions presented here are read and followed, including information regarding transport, storage, installation, and use of the SE2. Please also be aware of the specified environmental limitations of the product. [See [“Technical data” on page 40.](#)]

Throughout this manual, important safety information is included, with warning and caution notes. Please read the following information carefully, and all warning and caution information in the manual.



Indicates a potentially hazardous situation which, if not avoided, could result in injury or death.



Indicates a potentially hazardous situation which, if not avoided, could result in damage to property.

Safety of machinery, and safety-critical applications

The level of integrity offered by the SE2 control functions, for example, Stop/Start, Forward/Reverse, and Maximum Speed, is not sufficient for use in safety-critical applications without independent channels of protection. All applications where malfunction could cause injury or loss of life must be subject to a risk assessment and further protection provided where needed. Within the European Union, all machinery in which this product is used must comply with Directive 89/392/EEC, Safety of Machinery. In particular, the electrical equipment should comply with EN60204-1.



- SE2 units should be installed only by qualified electrical personnel and in accordance with local and national regulations and codes of practice.
- Electric shock hazard! Disconnect and ISOLATE the SE2 before attempting any work on it. High voltages are present at the terminals and within the drive for up to 10 minutes after the electrical supply has been disconnected.
- Where supply to the drive is through a plug and socket connector, do not disconnect until 10 minutes have elapsed after turning off the power supply.
- Ensure correct earthing (grounding) connections. The earth (ground) cable must be sufficient to carry the maximum supply fault current which normally is limited by the fuses or MCB.
- The STOP function does not remove potentially lethal high voltages. Be sure to ISOLATE the drive and wait 10 minutes before starting any work on it.
- If it is desired to operate the drive at any frequency/speed above the rated speed (P-503/P-511) of the motor, consult the manufacturers of the motor and the driven machine about suitability for over-speed operation.
- The fan (if fitted) inside the SE2 starts automatically when the heat sink temperature reaches approximately 45 degrees C.



- Carefully inspect the SE2 unit before installation to ensure it is undamaged.
- Indoor use only!
- Flammable material should not be placed close to the drive.
- The entry of conductive or flammable materials or foreign objects should be prevented.
- Relative humidity must be less than 95% (non-condensing).
- Ensure that the supply voltage, frequency, and number of phases (1 or 3 phase) correspond to the rating of the SE2 as delivered.
- An isolator should be installed between the power supply and the drive.
- Never connect the mains power supply to the output terminals U, V, or W.
- Protect the drive by using slow-blowing HRC fuses or MCB located in the mains supply of the drive.
- Do not install any type of automatic switchgear between the drive and the motor.
- Wherever control cabling is close to power cabling, maintain a minimum separation of 4 inches and arrange crossings at 90 degrees.
- Ensure that all terminals are tightened to the appropriate torque setting.

1.3 ELECTROMAGNETIC COMPATIBILITY (EMC)

The SE2 is designed to high standards of EMC and is optionally fitted with an internal EMC filter. This EMC filter is designed to reduce the conducted emissions back into the supply via the power cables for compliance with European standards.

It is the responsibility of the installer to ensure that the equipment or system into which the product is installed complies with the EMC legislation of the country of use. Within the European Union, equipment into which this product is incorporated must comply with 89/336/EEC, EMC.

For use on domestic supplies, shielded motor cable must be used with the shield terminated to earth ground on both the motor and drive sides. The installation must be carried out by qualified installation engineers, observing good wiring practice such as power and signal cable segregation and correct shielding techniques to minimize emissions. When installed in this way, an SE2 unit with a built-in filter has emission levels lower than those defined in EN61800-3, category C2 for first environments for shielded cable lengths of up to 5 meters.

For cable lengths longer than 5 meters, the emission levels may exceed those defined by EN61800-3, category C2. In this case, further mitigation methods, such as fitting an external filter) must be employed if the emission limits are to be maintained.

When used on industrial supplies, or second environments, the installation must be carried out by qualified installation engineers, observing good wiring practice such as power and signal cable segregation and correct shielding techniques to minimize emissions. The emissions limits defined by EN61800-3, category C3 (second environments) are maintained for shielded cable lengths of up to 25 meters. The cable shield should be connected to earth ground on both the drive and motor sides.

1.4 SUMMARY OF CERTIFICATIONS

The SE2 drive meets the following standards:

Standard	Description
EN61800-5-1	Safety requirements: electrical, thermal, and energy
EN61800-3	Adjustable speed electrical power drives systems, Part 3
EN55011	Limits and methods of measurement of radio interference characteristics of Industrial Equipment (EMC)
cUL	America (UL 508C) and Canada C22.2 No. 14

1.5 USER'S MANUAL PUBLICATION HISTORY

Date	Doc. No.	Nature of Change
15.9.2008	DPD00086	Original release
22.9.2008	DPD00086(A)	Rev. A: minor corrections to graphics and data; fault codes added
1.10.2008	DPD00086(B)	Rev. B: minor corrections to graphic; ratings data corrected
8.12.2008	DPD00086(C)	Rev. C: replaced Figure 7-1

2. ABOUT THE SE2 DRIVE

This chapter contains information about the SE2 drive, including how to identify the drive by its model number, with a list of all SE2 drive models and ratings.

2.1 IDENTIFYING THE DRIVE BY MODEL NUMBER

The model number of the SE2 AC drive appears on the shipping carton label and on the technical data label (drive nameplate) on the unit. The model number includes the drive and any options. The information provided by the model number is shown below:

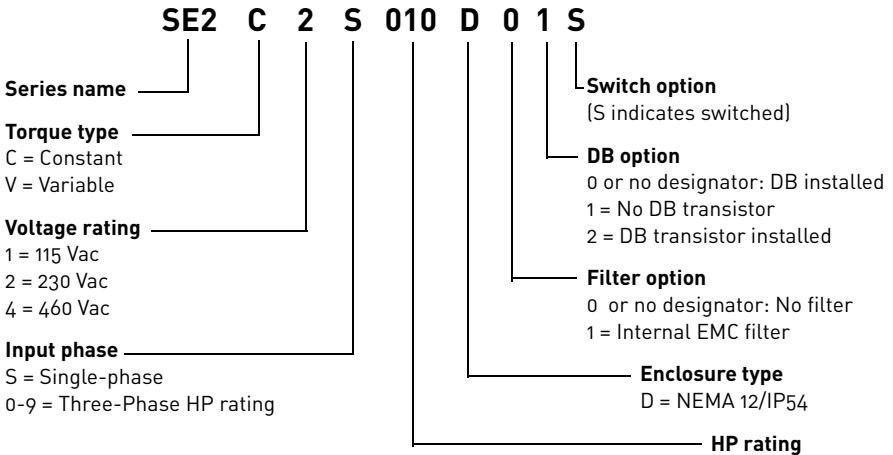

Figure 2-1: Drive model number format

Technical specifications for each of the the SE2 models are given in [“Technical data” on page 40](#).

See [“Drive model numbers” on page 9](#) for a list of all the SE2 drive model numbers.

2.2 DRIVE MODEL NUMBERS

The following chart lists each of the drive models, with horsepower, kW, output current (in amps), and frame size.

110-115V +/- 10% - 1 Phase Input - 3 Phase 230V Output (Voltage Doubler)				
HP Model Number	kW	HP	Output Current (A)	Frame Size
SE2C1S005D01	.37	0.5	2.3	1
SE2C1S010D01	.75	1.0	4.3	1
SE2C1S015D02	1.1	1.5	5.8	2
200-240V +/- 10% - 1 Phase Input				
HP Model Number	kW	HP	Output Current (A)	Frame Size
SE2C2S005D01	0.37	0.5	2.3	1
SE2C2S010D01	0.75	1	4.3	1
SE2C2S020D01	1.5	2	7	1
SE2C2S020D02	1.5	2	7	2
SE2C2S030D02	2.2	3	10.5	2
200-240V +/- 10% - 3 Phase Input				
HP Model Number	kW	HP	Output Current (A)	Frame Size
SE2C20005D01	.37	0.5	2.3	1
SE2C20010D01	0.75	1	4.3	1
SE2C20020D01	1.5	2	7	1
SE2C20020D02	1.5	2	7	2
SE2C20030D02	2.2	3	10.5	3
SE2C20050D02	4.0	5	18	3
380-480V +/- 10% - 3 Phase Input				
HP Model Number	kW	HP	Output Current (A)	Frame Size
SE2C40010D01	0.75	1	2.2	1
SE2C40020D01	1.5	2	4.1	1
SE2C40020D02	1.5	2	4.1	2
SE2C40030D02	2.2	3	5.8	2
SE2C40050D02	4	5	9.5	2
SE2C40075D02	5.5	7.5	14	3
SE2C40100D02	7.5	10	18	3

3. RECEIVING AND INSTALLATION

3.1 PRELIMINARY INSPECTION

Before storing or installing the SE2 AC drive, thoroughly inspect the device for possible shipping damage. Upon receipt:

1. Remove the drive from its package and inspect exterior for shipping damage. If damage is apparent, notify the shipping agent and your sales representative.
2. Remove the cover and inspect the drive for any apparent damage or foreign objects. Ensure that all mounting hardware and terminal connection hardware is properly seated, securely fastened, and undamaged.
3. Read the technical data label affixed to the drive and ensure that the correct horsepower and input voltage for the application has been purchased.
4. If you will be storing the drive after receipt, place it in its original packaging and store it in a clean, dry place free from direct sunlight or corrosive fumes, where the ambient temperature is not less than $-40\text{ }^{\circ}\text{C}$ ($-40\text{ }^{\circ}\text{F}$) or greater than $+60\text{ }^{\circ}\text{C}$ ($+149\text{ }^{\circ}\text{F}$).

 CAUTION	<p>EQUIPMENT DAMAGE HAZARD</p> <p>Do not operate or install any drive that appears damaged.</p> <p>Failure to follow this instruction can result in injury or equipment damage.</p>
--	--

5. If the SE2 unit has been stored without power applied for 30-36 months, special start-up procedures should be used to reform the high voltage filter capacitors before using the unit. Failure to exercise these procedures may result in extensive damage to the drive. Contact Technical Support for detailed instructions.

3.2 INSTALLATION PRECAUTIONS

Improper installation of the SE2 AC drive will greatly reduce its life. Be sure to observe the following precautions when selecting a mounting location. Failure to observe these precautions may void the warranty!

- Install the SE2 unit on a flat, vertical, flame-resistant, vibration-free mounting within a suitable enclosure, according to EN60529, if specific ingress protection ratings are required.
- The SE2 must be installed in a pollution degree 1 or 2 environment.
- Do not install the drive in a place subjected to high temperature, high humidity, excessive vibration, corrosive gases or liquids, or airborne dust or metallic

particles. See “Technical data” on page 40, for temperature, humidity, and maximum vibration limits for the SE2 drive.

- Do not mount the drive near heat-radiating elements or in direct sunlight.
- Mount the drive vertically and do not restrict the air flow to the heat sink fins.
- The drive generates heat. Allow sufficient space around the unit for heat dissipation.

3.3 MECHANICAL DIMENSIONS

The following table lists dimensions for the SE2 frame size 1, 2, and 3 models.

See the figures on the following pages for locations of dimensions. Dimensions are in inches and millimeters, with millimeters in parentheses.

Table 3-1: Dimensions of SE2 frame sizes 1-3

Frame		1		2			3	
Voltage (V)		110-115	200-240	110-115	200-240	380-480	200-240	380-480
KW		0.37-1.0	0.37-1.0	1.1	1.5-2.2	1.5-4.0	4	5.5-7.5
HP		0.5-1.0	0.5-1.0	1.5	2-3	2-5	5	7.5-10.0
Dimensions in inches (mm)	A	7.87 (200)		12.20 (310)			12.20 (310)	
	B	6.54 (166)		10.87 (276)			10.87 (276)	
	D	5.55 (141)		9.88 (251)			9.88 (251)	
	E	1.30 (33)		1.30 (33)			1.30 (33)	
	F	6.38 (162)		6.93 (176)			9.57 (243)	
	G	5.51 (140)		6.46 (164)			8.29 (210.5)	
	H	5.04 (128)		6.02 (153)			7.78 (197.5)	
	I	0.17 (4.2)		0.17 (4.2)			0.17 (4.2)	
J	0.33 (8.4)		0.33 (8.4)			0.33 (8.4)		

Control Terminal Torque settings of 0.5 Nm

Power Terminal Torque settings of 1 Nm

Note that the size 2 and 3 drives have 4 symmetrical mounting points.

Figure 3-1: Vacon SE2 dimensions

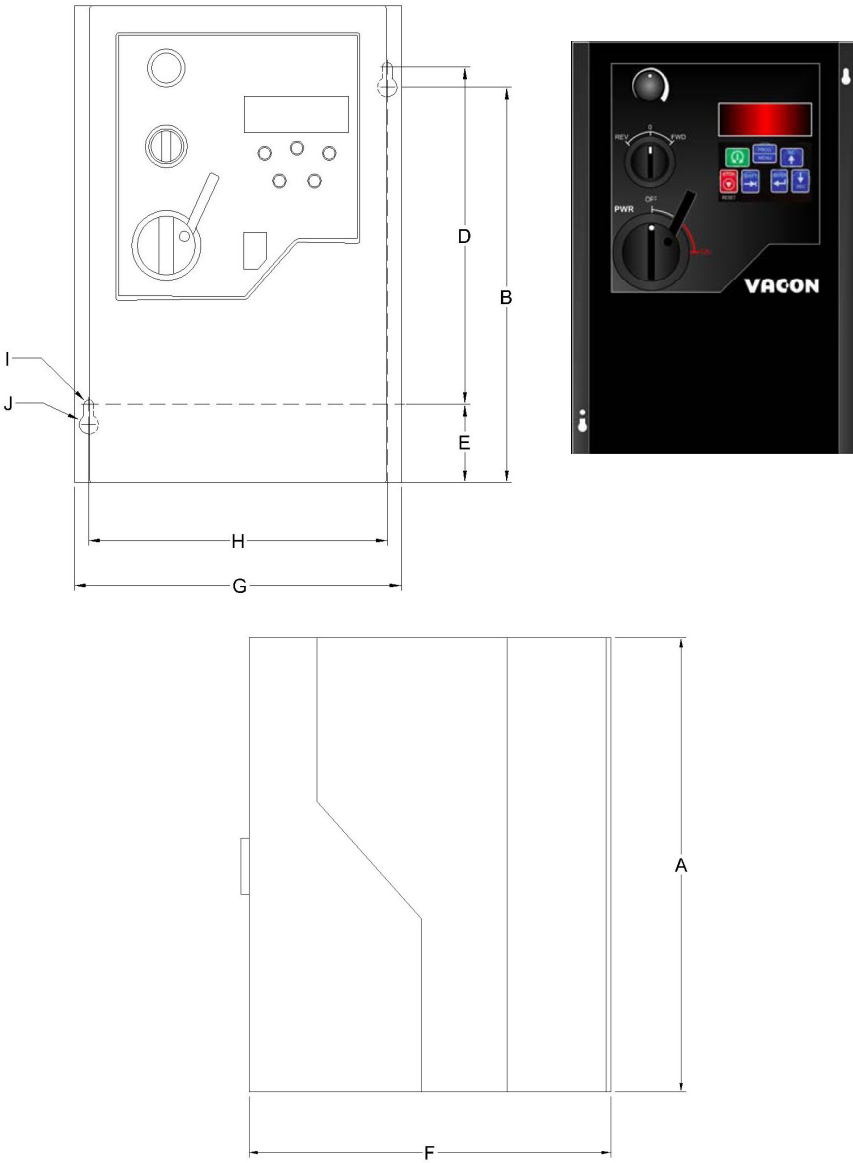

4. POWER WIRING

This chapter provides information about connecting power wiring to the SE2 drive.

 DANGER	<p>HAZARDOUS VOLTAGE</p> <ul style="list-style-type: none"> • Read and understand this manual in its entirety before installing or operating the SE2 drive. Installation, adjustment, repair, and maintenance of these drives must be performed by qualified personnel. • Disconnect all power before servicing the drive. WAIT 5 MINUTES until the DC bus capacitors discharge. • DO NOT short across DC bus capacitors or touch unshielded components or terminal strip screw connections with voltage present. • Install all covers before applying power or starting and stopping the drive. • The user is responsible for conforming to all applicable code requirements with respect to grounding all equipment. • Use the dedicated ground terminal to ground the drive unit. Do not use mounting screws, bolts, or the chassis. • Many parts in this drive, including printed circuit boards, operate at line voltage. DO NOT TOUCH. Use only electrically-insulated tools. <p>Before servicing the drive:</p> <ul style="list-style-type: none"> • Disconnect all power. • Place a "DO NOT TURN ON" label on the drive disconnect. • Lock the disconnect in the open position. <p>Failure to observe these precautions will cause shock or burn, resulting in severe personal injury or death.</p>
--	--

4.1 GENERAL WIRING INFORMATION

Be sure that the installation wiring conforms with local standards. Where local codes exceed these requirements, they must be followed.

4.1.1 Wiring Practices

When making power and control connections, observe these precautions:

- Never connect input AC power to the output terminals T1/U, T2/V, or T3/W. Damage to the drive will result.
- Power wiring to the motor must have the maximum possible separation from all other power wiring. Do not run in the same conduit; this separation reduces the possibility of coupling electrical noise between circuits.
- Cross conduits at right angles whenever power and control wiring intersect.

- Good wiring practice also requires separation of control circuit wiring from all power wiring. Since power delivered from the drive contains high frequencies which may cause interference with other equipment, do not run control wires in the same conduit or raceway with power or motor wiring.

4.1.2 Considerations for Power Wiring

Power wiring refers to the line and load connections made to terminals L1/R, L2/S, L3/T, and T1/U, T2/V, T3/W respectively. Select power wiring as follows:

- Use only VDE, UL or CUL recognized wire.
- Wire voltage rating must be a minimum of 300 V for 230 Vac systems and 600 V (Class 1 wire) for 400 Vac systems.
- Wire gauge must be selected based on 125% of the continuous input current rating of the drive. Wire gauge must be selected from wire tables for 75 °C insulation rating, and must be of copper construction. See “Ratings” on page 40 for the continuous output ratings for the drive.

See the following table for a summary of power terminal wiring specifications.

Table 4-1: Power terminal wiring specifications for the SE2 drive

Drive Size	Specifications
1	1.8 Nm (16 in-lbs) nominal torque or 2.0 Nm (18 in-lbs) maximum torque 1.5–10 mm ² (7–15 awg wire)
2	3.4 Nm (30 in-lbs) nominal torque 10–16 mm ² (5–7 awg wire)
3	4.0 Nm (35 in-lbs) nominal torque 25 mm ² (3 awg wire)

NOTE: Wire type not specified by the manufacturer. Some types of wire may not fit within the constraints of the conduit entry and bend radius inside the drive.

4.1.3 Grounding Guidelines

The ground terminal for each SE2 unit should be individually connected directly to the site ground bus bar (through the filter, if installed). SE2 ground connections should not loop from one drive to another, or to/from any other equipment. Ground loop impedance must conform to local industrial safety regulations. To meet UL regulations, UL approved ring crimp terminals should be used for all ground wiring connections.

If a system **ground fault monitor** is to be used, only Type B devices should be used to avoid nuisance tripping.

The **safety ground** (⊕) is required by code for the drive. One of these points must be connected to adjacent building steel (girder, joist), a floor ground rod, or bus bar.

Grounding points must comply with national and local industrial safety regulations and/or electrical codes.

The drive safety ground must be connected to the system ground. Ground impedance must conform to the requirements of national and local industrial safety regulations and/or electrical codes. The integrity of all ground connections should be checked periodically.

For **shield termination**, the safety ground terminal provides a grounding point for the motor cable shield. The motor cable shield connected to this terminal (drive end) should also be connected to the motor frame (motor end). Use a shield terminator or EMI clamp to connect the shield to the safety ground terminal. **Note:** When shielded cable is used for control and signal wiring, the shield should be grounded at the source end only, not at the drive end.

The **motor ground** must be connected to one of the ground terminals on the drive.

4.1.4 Wiring Precautions

Connect the drive according to the connection diagram shown in [Figure 4-1 on page 16](#), ensuring that motor terminal box connections match the output specifications of the drive.

For recommended cabling and wire sizing, see [“Technical data” on page 40](#).

Figure 4-1: Connection diagram for SE2 power wiring

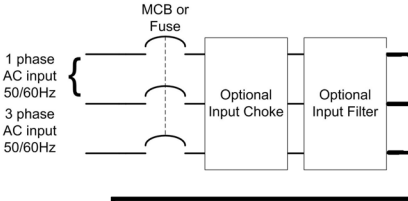

Note:

The default setting for the switch on the drive is FWD / REV and the motor speed is changed using the local potentiometer.

Changing the setting of P-721 will adjust the functionality of the FWD / REV switch.

Set P-721 = 5 to disable the operation of the reverse (REV) setting.

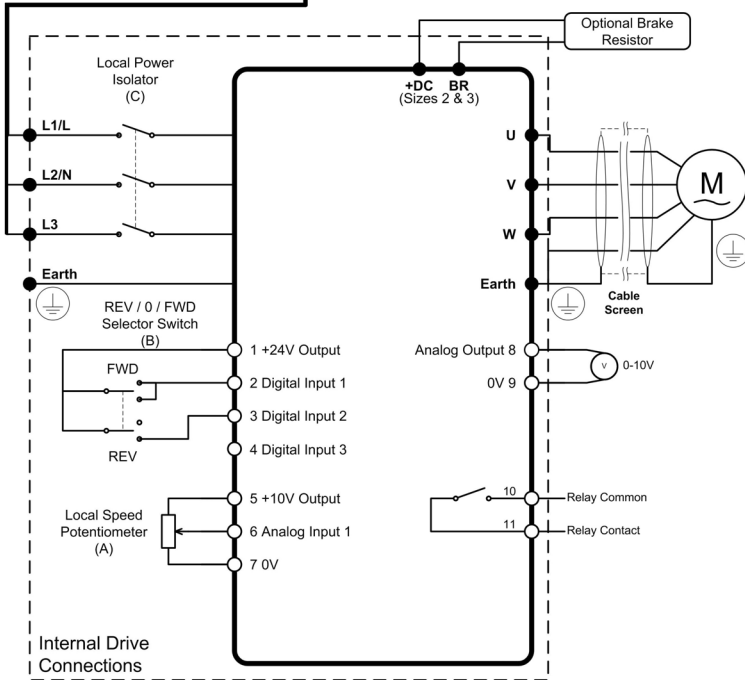

4.2 DRIVE AND MOTOR CONNECTIONS

For one-phase supply, power should be connected to L1/L and L2/N.

For three-phase supplies, power should be connected to L1, L2, and L3. Phase sequence is not important.

The motor should be connected to U, V, and W.

For drives with a dynamic brake transistor, an optional external braking resistor will need to be connected to +DC and BR when required. The brake resistor circuit should be protected by a suitable thermal protection circuit.

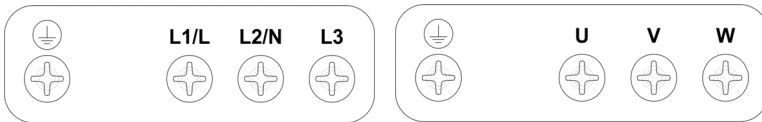

Figure 4-2: SE2 Size 1 connections

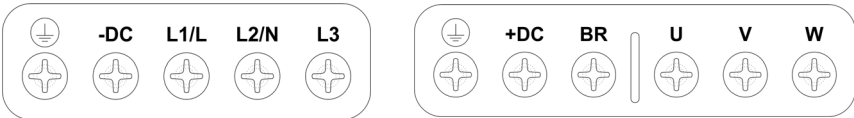

Figure 4-3: SE2 Size 2 and 3 connections

4.3 MOTOR TERMINAL BOX CONNECTIONS

Most general-purpose motors are wound for operation on dual voltage supplies. This is indicated on the nameplate of the motor.

Ensure that the motor is connected for the proper voltage configuration that matches the SE2 drive's output rating.

5. CONTROL WIRING

This chapter provides information about connecting control wiring to the SE2 drive.

5.1 CONTROL TERMINAL CONNECTIONS

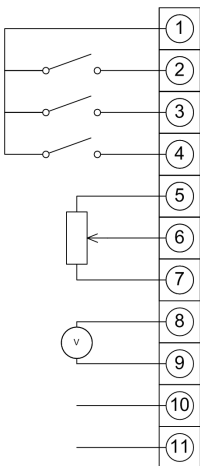

Control Terminal	Signal	Description
1	+24V user output	+24V, 100 mA
2	Digital input 1	Positive logic
3	Digital input 2	"Logic 1" input voltage range: 8V ... 30V DC "Logic 0" input voltage range: 0V ... 4V DC
4	Digital input 3 / Analog input 4	Digital: 8-30V Analog: 0-10V, 0-20 mA, or 4-20 mA
5	+10V user output	+10V, 10 mA, 1k Ohms minimum
6	Analog input 1 / Digital input 4	Analog: 0-10V, 0-20 mA, or 4-20mA Digital: 8-30V
7	0V	User ground-connected terminal 9
8	Analog output / Digital output	Analog: 0-10V, 20 mA maximum Digital: 0-24V
9	0V	User ground-connected terminal 7
10	Relay common	
11	Relay NO contact	Contact 250Vac, 6A / 30Vdc, 5A

5.2 RJ45 DATA CONNECTION

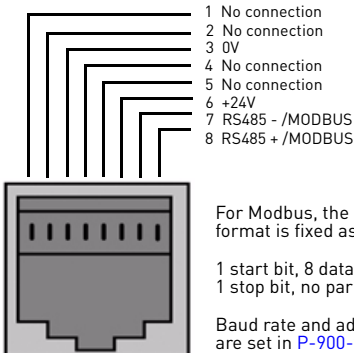

For MODBUS RTU register map information, please refer to ["Parameters" on page 22](#).







When using MODBUS control, the analog and digital input can be configured as in MODBUS control mode (P201=3 or 4).

6. OPERATION

This chapter describes the keypad and displays, and how to change parameters. It also describes how to control the SE2 using the keypad or using terminal control mode.

6.1 USING THE KEYPAD

Use the keypad and display to configure and monitor the SE2 operation.

	RUN	When in keypad mode, this key is used for starting a stopped drive or to reverse the direction of rotation if bi-directional keypad mode is enabled.
PROG	PROGRAM	This key is used for displaying real-time information, for accessing and entering parameter edit mode, and for storing parameter changes.
	INC	This key is used to increase speed in real-time mode, or to increase parameter values in parameter edit mode.
	DEC	This key is used to decrease speed in real-time mode, or to decrease parameter values in parameter edit mode.
	RESET/STOP	Use this key to reset a tripped drive. When in Keypad mode, use it to STOP a running drive.
	SHIFT	When in programming mode, and viewing a parameter, use this key to access the parameter so the data can be changed with the UP or DOWN arrows.
	ENTER	This key enters the data into memory.

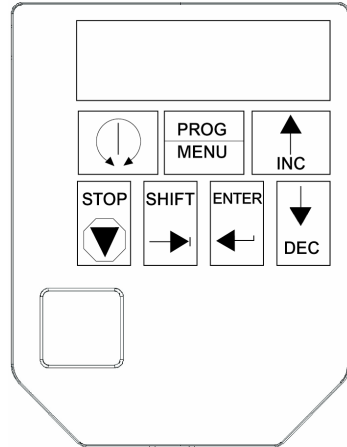

6.2 CHANGING PARAMETERS

To change a parameter value in **Level 1**, press and release the PROG key while the drive displays STOP. The display changes to P-010, indicating parameter 010.

To access all parameters (**Level 2**), hold down the SHIFT key and press the PROG key.

To change Level 1 or Level 2 parameters, use the UP or DOWN arrows to select the desired parameter to view or change. To display the value of the parameter, press and release the SHIFT key. To change the value, use the UP or DOWN keys. Store the change by pressing and releasing the ENTER key.

To return to real-time mode, press and release the PROG key. The display shows STOP if the drive is stopped, or displays the real-time information (for example, speed) if the drive is running.

6.3 RESETTING FACTORY DEFAULT SETTINGS

To reset factory default parameter settings, press the UP, DOWN, and STOP keys for more than two seconds. The display shows *P-DEF*. Press the STOP key to acknowledge and reset the drive.

6.4 TERMINAL CONTROL

When delivered, the SE2 is in the factory default state, meaning that it is set to operate in terminal control mode and all parameters (P-xxx) have the default values as indicated in ["Parameters" on page 22](#). To use terminal control:

1. Connect the motor to the drive, checking the motor connection matches that of the voltage rating.
2. Enter the motor data from the nameplate. **P-509** = motor rated voltage, **P-510** = motor rated current, **P-503** = motor rated frequency.
3. Connect a control switch between the control terminals 1 and 2, ensuring that the contact is open (drive disabled)
4. Connect a potentiometer (1k Ω to 10k Ω maximum) between terminals 5 and 7, and the wiper to terminal 6.
5. With the potentiometer set to zero, switch on the supply to the drive. The display shows *StoP*.
6. Close the control switch, terminals 1-2. The drive is now enabled and the output frequency and speed are controlled by potentiometer. The display shows zero speed in Hz (*H 0.0*) with the potentiometer turned to minimum.
7. Turn the potentiometer to maximum. The motor will accelerate to 60 Hz (the default value of **P-302**) under the control of the accelerating ramp time **P-402**. The display shows 60 Hz (*H 60.0*) at max speed.
8. To display motor current (A), briefly press the PROG key.
9. Press PROG again to return to the speed display.
10. To stop the motor, either turn the potentiometer back to zero, or disable the drive by opening the control switch (terminals 1-2). If the enable/disable switch is opened, the drive decelerates to stop, at which time the display shows *StoP*. If the potentiometer is turned to zero with the enable / disable closed, the display shows 0.0 Hz (*H 0.0*). If left in this state for 20 seconds, the drive goes into standby mode, and the display shows *StAnDbY*, waiting for a speed reference signal.

6.5 KEYPAD CONTROL

To control the SE2 from the keypad in a forward direction only, set **P-201** = 1, and follow these steps:

1. Connect the motor as for terminal control (described in "Terminal control" on page 20).
2. Enable the drive by installing a hard-wired jumper between control terminals 1 and 2. The display shows $5\text{E}\sigma\text{P}$.
3. Press the RUN key. The display shows $H _ _$.
4. Press the UP key to increase speed.
5. The drive runs in a forward direction, increasing speed until you release the UP key.



The rate of acceleration is controlled by the setting of **P-402**. Be sure to check this before starting.

6. Press the DOWN key to decrease speed. The drive decreases speed until you release the DOWN key. The rate of deceleration is controlled by the setting in **P-403**.
7. Press the STOP key. The drive decelerates to rest at the rate set in **P-403**.
8. The display shows $5\text{E}\sigma\text{P}$, at which point the drive is disabled.

To preset a target speed before enabling the drive:

1. Press the RUN key while the drive is stopped. The display shows the target speed.
2. Use the UP and DOWN keys to adjust the speed as needed, then press the STOP key to return the display to $5\text{E}\sigma\text{P}$.
3. Press the RUN key to start the drive accelerating to the target speed.

To allow the SE2 to be controlled from the keypad in a forward or reverse direction, set **P-201** = 2, and follow these steps:

*Note: Operation is the same as when **P-201** = 1, for start, stop, and changing speed.*

1. Press the RUN key. The display changes to $H _ _$.
2. Press the UP key to increase speed.
3. The drive runs in a forward direction, increasing speed until you release the UP key.



The rate of acceleration is controlled by the setting of **P-402**. The maximum speed is the speed set in **P-302**. Be sure to check this before starting.

4. To reverse the direction of rotation of the motor, press the RUN key again.

7. PARAMETERS

This chapter describes the Level 1 and Level 2 parameters for the SE2 drive, their defaults, and options for user control.

Note that all parameters can be addressed by adding **40000** to the parameter number. For example, **parameter 201 (Input Mode)** can be addressed by Modbus address **40201**.

7.1 LEVEL 1 PARAMETERS

The following chart lists all the Level 1 parameters and their options.

Par.*	Description	Range	Default	Explanation
P-010	Trip log	Last four trips stored	Read only	Previous 4 trips stored in order of occurrence, with the most recent first. UV trip is stored only once. More fault event logging functions are accessible through parameter group zero .
	P-010 displays the most recent four trips, together with the run-time stamp. For example: U-Volts, 576h, 42 28 means undervoltage after 576 hrs., 42 m, 28 s. The most recent trip is always displayed first. The time stamp is displayed by pressing the DOWN key repeatedly. Pressing the DOWN key again displays the next most recent fault message, and so forth. Standby mode is enabled automatically when the drive is at zero speed for >20s.			
P-201	Terminal / Keypad / Modbus / PI Drive Control Mode Selection	0: Terminal control 1: Keypad control - FWD 2: Keypad control-FWD and REV 3: Modbus network control with internal accel/decel ramps 4: Modbus network control with accel/decel ramp adjustment 5: User PI control 6: User PI control with analog input 1 summation	0	Primary control mode for SE2. 0: Terminal control 1: Uni-directional keypad control. Keypad START button does not reverse direction. 2: Bi-directional keypad control. Keypad START button toggles between FWD and REV. 3: Control via Modbus RTU (RS485) comms interface using the internal accel/decel ramps 4: Control via Modbus RTU (RS485) comms interface with accel/decel ramps updated via Modbus 5: User PI control with external feedback signal 6: User PI control with external feedback signal & summation with analog input

* **Note** that all parameters can be addressed by adding **40000** to the parameter number. For example, **parameter 201 (Input Mode)** can be addressed by Modbus address **40201**.

Par.*	Description	Range	Default	Explanation
P-203	Mains loss Stop mode select	0: Ramp stop (brown-out ride-through) 1: Coast to stop 2: Ramp to stop (fast stop)	0	If the supply is lost and P-203= 0, the drive tries to keep running by reducing the speed of the load using the load as a generator. If P-203=2, the drive ramps to stop using the P-405 decel ramp when mains supply is lost. This also activates constant power braking mode for normal braking.
P-301	Minimum speed	0	0 Hz	Minimum speed limit, Hz or rpm. See P-511.
P-302	Maximum speed	up to 500 Hz	60 Hz	Maximum speed limit, Hz or rpm. See P-511.
P-303	Preset speed 1	0..500 Hz	0 Hz	Sets jog / preset speed 1
P-402	Acceleration ramp time	0 to 600s	5s	Acceleration ramp time from 0 to base speed [P-503] in seconds
P-403	Deceleration ramp time	0 to 600s	5s	Deceleration ramp time from base speed [P-503] to standstill, in seconds. When set to zero, fastest possible ramp time without trip is activated.
P-405	2nd decel ramp time (Fast Stop)	0...25.0s	0	2nd deceleration ramp time from base speed [P-503] to standstill, in seconds. If set to zero, the drive coasts to stop. Select with fast stop function via digital input setting, or on mains loss as set by P-203.
P-502	Voltage boost	0.0 to 25.0% of max. output voltage	Motor power dependent	Applies an adjustable boost to SE2 voltage output at low speed to assist with starting "sticky" loads. For continuous applications at low speed using a forced ventilation motor.

* **Note** that all parameters can be addressed by adding **40000** to the parameter number. For example, **parameter 201 (Input Mode)** can be addressed by Modbus address **40201**.

Par.*	Description	Range	Default	Explanation
P-700	Analog output function select	Digital output mode: 0: Drive enabled 1: Drive healthy 2: Motor at target speed 3: Drive tripped 4: Motor speed >= limit 5: Motor current >= limit 6: Motor speed < limit 7: Motor current < limit Analog output mode: 8: Motor speed 9: Motor current	8	Digital output mode: Options 0 to 7 select a digital voltage output signal Disabled: 0V Enabled: +24V (25mA limit) Options 4 to 7: digital output is enabled using level set in P-721 Analog output mode: Option 8: Motor speed signal range 0..10V = 0..500 Hz (P-302) Option 9: Motor current signal range 0...10V = 0...200% of P-510
	User relay output select	0: Drive enabled 1: Drive healthy 2: Motor at target speed 3: Drive tripped 4: Motor speed >= limit 5: Motor current >= limit 6: Motor speed < limit 7: Motor current < limit	1	Defines the function of the user relay, when the operating conditions are met. Disabled: Contacts open Enabled: Contacts closed Options 4-7: relay output is enabled using level set in P-739 .

* **Note** that all parameters can be addressed by adding **40000** to the parameter number. For example, **parameter 201 (Input Mode)** can be addressed by Modbus address **40201**.

7.2 LEVEL 2 PARAMETERS

The following chart lists all the Level 2 parameters and their options.

Par.*	Description	Range	Default	Explanation
P-205	Analog input format	0..10V, b..10V, 0..20mA, t 4..20mA, r 4..20mA t 20..4mA r 20..4mA	0..10V	Configures the voltage or current format of the analog input signal. b 0..10V can be used for bipolar input signals. A 50% offset can be applied to P-206 and 200% scaling in P-207 gives +/- P-302 . "t" indicates the drive will trip if signal is removed when drive is enabled. "r" indicates the drive will ramp to Preset Speed 1 if signal is removed when drive is enabled.
P-206	Analog input offset	-500.0 ... 500.0%	0%	Introduces an offset to the analog input level with a resolution 0.1%
P-207	Analog input span	0 ... 500.0%	100%	Analog input scaling, resolution 0.1%

* **Note** that all parameters can be addressed by adding **40000** to the parameter number. For example, **parameter 201 (Input Mode)** can be addressed by Modbus address **40201**.

Par.*	Description	Range	Default	Explanation
P-211	2nd analog input format	0..10V, 0..20mA, t 4..20mA, r 4..20mA t 20..4.mA r 20...4mA	0...10	Selects the format of the 2nd analog input. "t" indicates the drive will trip if signal is removed when drive is enabled. "r" indicates the drive will ramp to Preset Speed 1 if signal is removed when drive is enabled.
P-304	Preset speed 2	0..500 Hz	0 Hz	Sets jog / preset speed 2
P-305	Preset speed 3	0..500 Hz	0 Hz	Sets jog / preset speed 3
P-306	Preset speed 4	0..500 Hz	0 Hz	Sets jog / preset speed 4
P-407	DC injection on stop	0 to 25.0s	0 (disabled)	When > 0, DC injection braking activated when speed reaches zero with stop signal applied. Only applied on disable (Stop), not on enable. Uses the level set in P-502.
P-410	Brake chopper enable (not S1)	0: Disabled 1: Enabled with s/w protection 2: Enabled without s/w protection	0	Software protection for standard brake resistors (200W).
P-501	Energy optimiser	0: Disabled 1: Enabled	0	When enabled, automatically reduces applied motor voltage on light load. Minimum value is 50% of nominal.
P-503	Motor rated frequency	25 Hz to 500 Hz	60 Hz	Rated (nameplate) frequency of the motor
P-504	Skip frequency hysteresis band	0..500 Hz	0 Hz	Set P-503 before adjusting. Speed reference held at upper or lower skip frequency limit until input signal reaches the opposite skip frequency limit. Speed ramps through the skip frequency band at a rate set by P-402 and P-403.
P-505	Skip frequency	0..500 Hz	0 Hz	Set P-503 before adjusting. Skip frequency center point.
P-509	Motor rated voltage	0, 20V to 250V 0, 20V to 500V	230V 460V	Rated (nameplate) voltage of the motor (Volts). Value limited to 250V for low-voltage drives. Setting to zero disables voltage compensation.
P-510	Motor rated current	25%-100% of drive rated current	Drive rating	Rated (nameplate) current of the motor. Sets overload protection.
P-511	Motor rated speed	0 to 30,000 rpm	0	When non-zero, all speed-related parameters are displayed in rpm.

* Note that all parameters can be addressed by adding 40000 to the parameter number. For example, parameter 201 (Input Mode) can be addressed by Modbus address 40201.

Par.*	Description	Range	Default	Explanation
P-512	V/f characteristic frequency adjust	0 ... P-503	0.0 Hz	Sets the frequency at which the adjustment voltage set in P-513 is applied. [See page 28.]
P-513	V/f characteristic adjustment voltage	0 ... P509	0	Adjusts the applied motor voltage to this value at the frequency set in P-512. [See page 28.]
P-608	Terminal mode restart function	Edge-r, Auto-0 .. Auto-5	Auto-0	<p>Edge-r: If the drive is powered up with digital input 1 closed (enabled), the drive will not run. The switch must be opened and closed after power-up or after clearing a trip for the drive to run.</p> <p>Auto-0: Drive will run when digital input 1 is closed (if not tripped).</p> <p>Auto-1...5: The drive will make 1..5 attempts to automatically restart after a trip (25s between attempts). If fault has cleared, the drive restarts. To reset the counter, drive must be powered-down. Reset the counter on the keypad or by re-enabling the drive.</p>
P-721	Digital input function select	0-12	0	Defines the function of the digital inputs depending on the control mode setting in P-201. See "Analog and digital input configurations" on page 30, for more information.
P-739	User relay output limit	0.0 to 100%	100%	Sets the limit for P-705.
P-802	Keypad mode restart function	0: Minimum speed 1: Previous speed 2: Minimum speed (Auto-run) 3: Previous speed (Auto-run)	1	If set to 0 or 2, the drive will always start from minimum speed. If set to 1 or 3, the drive ramps up to the operating speed prior to the last STOP command. If set to 2 or 3, the status of digital input 1 controls the drive to start or stop. The start and stop keys on the drive will not function in this case.
P-803	Effective switching frequency	4 .. 32kHz	8 / 16 kHz	Sets maximum effective switching frequency of the drive. If "rEd" appears, switching frequency is reduced to the level in P00-14 due to excessive drive heatsink temp. Defaults are model-dependent.

* **Note** that all parameters can be addressed by adding **40000** to the parameter number. For example, **parameter 201 (Input Mode)** can be addressed by Modbus address **40201**.

Par.*	Description	Range	Default	Explanation
P-809	Display speed scaling factor	0.000 to 6.000	0	Custom scaling factor applied to drive speed. If P-511=0, speed in Hz is scaled by this factor. If P-511>0, speed in rpm is scaled. Displayed as a real-time variable on the drive display, shown by "c".
P-811	Access code definition	0 - 9,999	0	Allows only selected parameter access.
P-816	Spin Start (S2 and S3 only) DC injection on start (S1)	0: Disabled 1: Enabled	0	When enabled, the drive starts from the detected motor rotor speed. Short start delay possible if rotor stationary. Recommended for high-inertia load applications. For Size 1 drives, setting this parameter to 1 enables DC injection braking on enable. Set the duration and levels with P-407 and P-502, respectively.
P-850	User PI operating mode	0: Direct 1: Inverse	0	If an increasing feedback signal should increase the speed of the motor, set to "Inverse" mode.
P-851	User PI feedback select	0: 2nd analog input (T4) 1: 1st analog input (T6) 2: Motor load current	0	This parameter selects the feedback signal source.
P-852	User PI proport. gain	0.0 ... 30.0	1.0	Higher value used for high inertia. Too high a value gives instability.
P-853	User PI integral time constant	0.0s ... 30.0s	1.0s	High value gives slower, more damped response.
P-866	User PI digital reference	0 ... 100%	0.0%	Sets the preset reference used when P-869=0.
P-869	User PI reference select	0: Digital 1: Analog	0	Sets the source for the PI control reference signal. When set to 1, analog input 1 is used.
P-900	Modbus enable / baudrate select	OP-buS (fixed at 115.2 kbps) 9.6k to 115.2 kbps (Modbus)	OP-buS	OP-buS disables Modbus. Setting a baud rate enables Modbus at that baudrate. Adr: Unique drive address for communication network.
P-902	Serial communications address	Adr: 0 disable, 1 .. 63	1	Time before a trip during a comms loss can be set in ms.
P-903	Trip enable / delay	0 (no trip, t 30, 100, 1000, 3000 (ms) r 30, 100, 1000, 3000 (ms)	t 3000 (3 sec trip)	"0" = disables the comms trip. "t" = drive will trip if time is exceeded. "r" = drive ramps to stop if the time is exceeded.

* Note that all parameters can be addressed by adding 40000 to the parameter number. For example, **parameter 201 (Input Mode)** can be addressed by Modbus address **40201**.

7.3 ADJUSTING VOLTAGE / FREQUENCY (V/F) CHARACTERISTICS

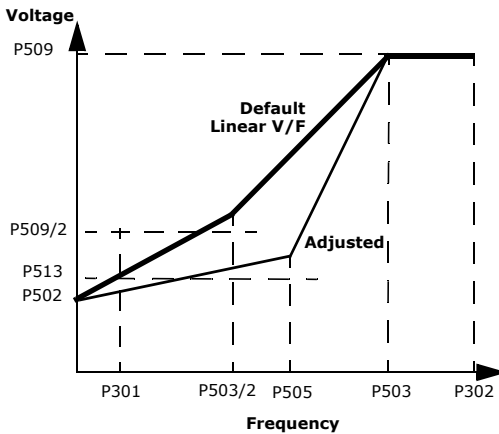

Figure 7-1. Voltage / frequency relationship

The V/f characteristic is defined by several parameters, as shown in Figure 7-1. Reducing the voltage at a particular frequency reduces the current in the motor and therefore reduces the torque and power. The V/f curve can be further modified by using [P-513](#) and [P-512](#), where P-513 determines the percentage increase or decrease of the voltage applied to the motor at the frequency specified in P-512. This can be useful if motor instability is experienced at certain frequencies. In this case, increase or decrease the voltage (P-513) at the speed of the instability (P-512).

For applications requiring energy savings, typically HVAC and pumping applications, the energy optimiser ([P-501](#)) parameter can be enabled. This automatically reduces the applied motor voltage on light loads.

7.4 P-00 READ ONLY DRIVE STATUS PARAMETERS (GROUP ZERO)

If you scroll to **P-00**, pressing SHIFT then displays “P-00 A”, where **A** represents the secondary number within P-00 (from 1-20). You can then scroll to the required P-00 parameter.

To display the value of that particular group zero parameter, press SHIFT again.

For parameters having multiple values (for example, software ID), pressing the UP or DOWN keys displays the different values within that parameter.

To return to the next level up, press ENTER. Pressing PROG (without pressing the UP or DOWN keys) changes the display to the next level up (main parameter level, that is, P-000). If the UP or DOWN keys are pressed while on the lower level (for example, P00-05), to change the P-00 index, press PROG to display that parameter value.

The following parameters are used for determining and monitoring status of a drive.

Par.	Description	Display range	Explanation
P00-01	1st analog input value	0 ... 100%	100% = max. input voltage
P00-02	2nd analog input value	0 ... 100%	100% = max. input voltage
P00-03	Speed reference input	-P1-302 ... P1-302	Displayed in Hz if P-511 = 0; otherwise, displayed in rpm. The '302' refers to the frequency programmed in P-302.
P00-04	Digital input status	Binary value	Drive digital input status
P00-05	Reserved	0	Reserved
P00-06	Reserved	0	Reserved
P00-07	Applied motor voltage	0 ... 600V AC	Value of RMS voltage applied to motor
P00-08	DC bus voltage	0 ... 1000V DC	Internal DC bus voltage
P00-09	Internal heatsink temperature	-20 ... 100 degrees C	Temperature of heatsink in degrees C
P00-10	Hours run meter	0 to 99,999 hours	Unaffected by resetting factory parameters
P00-11	Run time since last trip (1)	0 to 99,999 hours	Run-time clock stopped by drive disable (or trip); reset on next enable only if a trip occurred. Reset also on next enable after a drive power-down.
P00-12	Run time since last trip (2)	0 to 99,999 hours	Run-time clock stopped by drive disable (or trip); reset on next enable only if trip occurred (undervoltage not considered a trip). Not reset by power down / power up cycling unless a trip occurred prior to power down.
P00-13	Run time since last disable	0 to 99,999 hours	Run-time clock stopped on drive disable; value reset on next enable.
P00-14	Drive effective switching frequency	4..32 kHz	Actual drive effective output switching frequency. This value may be lower than the selected frequency in P-803 if the drive is too hot. The drive automatically reduces the switching frequency to prevent an over-temperature trip and maintain operation.
P00-15	DC bus voltage log	0 ... 1000V	8 most recent values prior to trip
P00-16	Thermistor temperature log	-20 ... 120 degrees C	8 most recent values prior to trip
P00-17	Motor current	0 to 2x rated current	8 most recent values prior to trip
P00-18	Software ID, I/O, and motor control	examples: "1.00", "47AE"	Version number and checksum. "1" on left hand side indicates I/O processor; "2" indicates motor control.
P00-19	Drive serial number	000000 ... 999999 00-000 ... 99-999	Unique drive serial number. Example: 540102 / 32 / 005
P00-20	Drive identifier	Drive rating	Drive rating, drive type. Ex: 0.37, 1 230, 3P-out

8. ANALOG AND DIGITAL INPUT CONFIGURATIONS

This chapter provides information about wiring and connections for terminal mode, keypad mode, with examples of typical applications for which you might use the terminal mode with the SE2 drive.

8.1 TERMINAL MODE (P-201=0)

(Page 1 of 2)

Par. 721	Digital input 1 (T1)	Digital input 2 (T2)	Digital input 3 (T4)			Analog input (T6)	Comments
0	Open: Stop (disable) Closed: Run (enable)	Open: Forward run Closed: Reverse run	Open: Analog speed ref Closed: Preset speed 1			Analog input 1 reference	
1	Open: Stop (disable) Closed: Run (enable)	Open: Analog spd ref Closed: Preset spd 1/2	Open: Preset spd 1 Closed: Preset spd 2			Analog input 1 reference	
2	Open: Stop (disable) Closed: Run (enable)	Dig. input 2	Dig. input 3	Preset spd		Open: Preset speeds 1-4 Closed: Max. speed (P-302)	4 preset speeds selectable. Analog input used as digital input Closed status: 8V < Vin < 30V
		Open	Open	1			
		Closed	Open	2			
		Open	Closed	3			
		Closed	Closed	4			
3 *	Open: Stop (disable) Closed: Run (enable)	Open: analog spd ref Closed: Preset spd 1	External trip input: Open: Trip Closed: Run			Analog input 1 reference	Connect external thermistor type PT100 or similar to digital input 3
4	Open: Stop (disable) Closed: Run (enable)	Open: analog input 1 Closed: analog input 2	Analog input 2 reference			Analog input 1 reference	Switches between analog inputs 1 and 2
5	Open: Fwd Stop Closed: Fwd Run	Open: Reverse stop Closed: Reverse run	Open: Analog spd ref Closed: Preset spd 1			Analog input 1 reference	Closing both digital inputs 1 and 2 causes a fast stop (P-405)
6 *	Open: Stop (disable) Closed: Run (enable)	Open: Forward Closed: Reverse	External trip input: Open: Trip Closed: Run			Analog input 1 reference	Connect external thermistor type PT100 or similar to digital input 3
7	Open: Stop (disable) Closed: Fwd Run (enable)	Open: Stop (disable) Closed: Reverse run (enable)	External trip input: Open: Trip Closed: Run			Analog input 1 reference	Closing both digital inputs 1 and 2 causes a fast stop (P-405)
8	Open: Stop (disable) Closed: Run (enable)	Open: Forward Closed: Reverse	Digital input 3	Analog input 1	Preset spd		
			Open	Open	1		
			Closed	Open	2		
			Open	Closed	3		
			Closed	4			

(Page 2 of 2)

Par. 721	Digital input 1 (T1)	Digital input 2 (T2)	Digital input 3 (T4)		Analog input (T6)	Comments
9	Open: Stop (disable) Closed: Fwd Run (enable)	Open: Stop (disable) Closed: Reverse run (enable)	Digital input 3	Analog input 1	Preset speed	Closing both digital inputs 1 and 2 causes a fast stop (P-405)
			Open	Open	1	
			Closed	Open	2	
			Open	Closed	3	
			Closed	Closed	4	
10	Normally open (NO) Momentary close to run	Normally closed (NC) Momentary open to stop	Open: Analog spd ref Closed: Preset spd 1		Analog input 1 reference	
11	Normally open (NO) Momentary close to run	Normally closed (NC) Momentary open to stop	Normally open (NO) Momentary close to rev		Analog input 1 reference	Closing both digital inputs 1 and 2 causes a fast stop (P-405)
12	Open: Stop (disable) Closed: Run (enable)	Open: Fast stop (disable) Closed: Run (enable)	Open: Analog spd ref Closed: Preset spd 1		Analog input 1 reference	

* **NOTE:** Negative preset speeds are inverted if Run Reverse is selected.

8.2 TYPICAL APPLICATIONS FOR TERMINAL MODE

The diagrams on the following pages illustrate applications where **parameter 201** (control mode selection) is set to **0** (terminal control mode), and the settings for **parameter 721** (digital input function select) control the function of the digital inputs:

8.2.1 Analog speed input with 1 preset speed and Fwd / Rev switch:

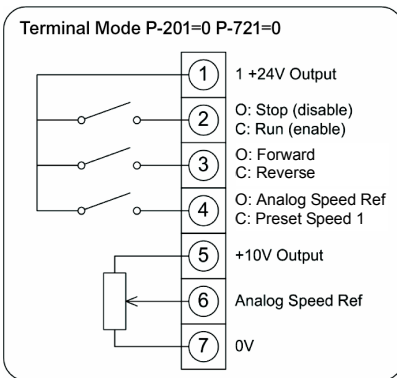

Parameter 721 is set to 0.

8.2.2 Analog speed input with 2 preset speeds:

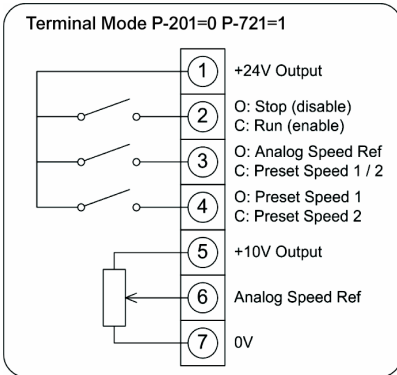

Parameter 721 is set to 1.

8.2.3 Four preset speeds and Fwd / Rev switch:

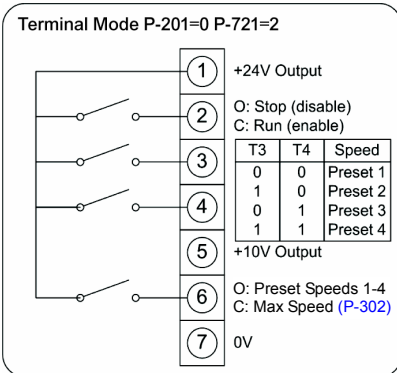

Parameter 721 is set to 2.

8.2.4 Analog speed input with 1 preset speed and motor thermistor trip:

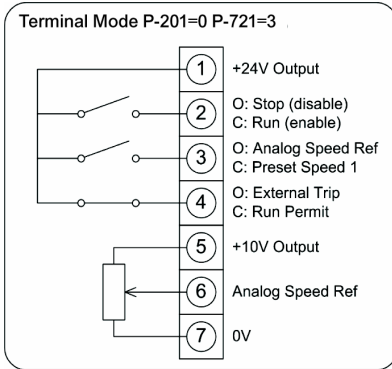

Parameter 721 is set to 3.

8.2.5 Local or remote analog speeds (2 analog inputs):

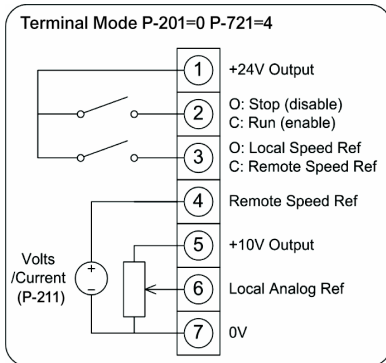

Parameter 721 is set to 4.

8.2.6 Push button Fwd / Rev / Stop with fast stop using 2nd deceleration ramp:

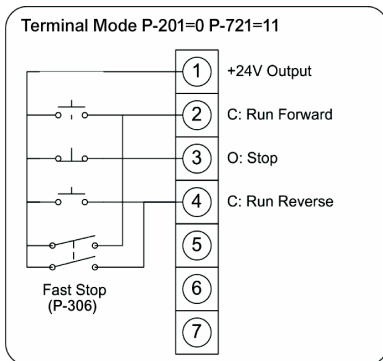

Parameter 721 is set to 11.

8.3 KEYPAD MODE (P-201 = 1 OR 2)

Par. 721	Digital input 1 (T1)	Digital input 2 (T2)	Digital input 3 (T4)	Analog input (T6)	Comments
0, 1, 5, 8.. 12	Open: Stop (disable) Closed: Run (enable)	Closed: remote UP push-button	Closed: remote DOWN push-button	Open: Forward +24V: Reverse	
2	Open: Stop (disable) Closed: Run (enable)	Closed: remote UP push-button	Closed: remote DOWN push-button	Open: Keypad spd ref +24V: Preset spd 1	
3*	Open: Stop (disable) Closed: Run (enable)	Closed: remote UP push-button	External trip input: Open: Trip Closed: Run	Closed: remote DOWN push-button	Connect external thermistor type PT100 or similar to digital input 3
4	Open: Stop (disable) Closed: Run (enable)	Closed: remote UP push-button	Open: Keypad spd ref Closed: Analog input 1	Analog input 1	
6*	Open: Stop (disable) Closed: Run (enable)	Open: Fwd run Closed: Rev run	External trip input: Open: Trip Closed: Run	Open: Keypad spd ref +24V: Preset spd 1	Connect external thermistor type PT100 or similar to digital input 3
7	Open: Fwd Stop Closed: Fwd Run	Open: Rev stop Closed: Rev run	External trip input: Open: Trip Closed: Run	Open: Keypad spd ref +24V: Preset spd 1	Closing both digital inputs 1 and 2 causes a fast stop [P-405]

* NOTE: By default, if the enable signal is present, the drive will not be enabled until the START button is pressed. To automatically enable the drive with the enable signal is present, set P-802 = 2 or 3. This then disables the use of the START or STOP buttons.

The following example shows a remote push-button speed control with Forward / Reverse. Parameter 721 is set to 0; Parameter 201 is set to 1 or 2.

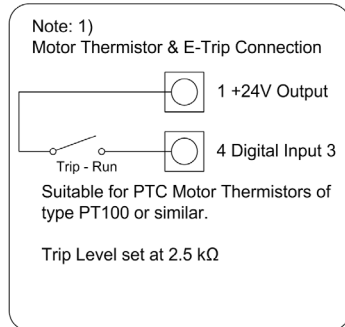
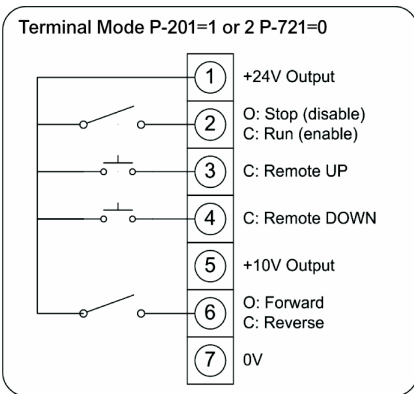

8.4 MODBUS CONTROL MODE (P-201 = 3 OR 4)

Par. 721	Digital input 1 (T1)	Digital input 2 (T2)	Digital input 3 (T4)	Analog input (T6)	Comments
0, 2, 4, 5, 8...12	Open: Stop (disable) Closed: Run (enable)	No effect	No effect	No effect	Run and stop commands given via the RS485 link and digital input 1 must be closed for the drive to run.
3*	Open: Stop (disable) Closed: Run (enable)	Open: Master speed ref Closed: Preset speed 1	External trip input: Open: Trip Closed: Run	No effect	Connect external thermistor type PT100 or similar to digital input 3
6*	Open: Stop (disable) Closed: Run (enable)	Open: Master speed ref Closed: Analog input	External trip input: Open: Trip Closed: Run	Analog input reference	Master speed ref: Start and Stop controlled via RS485. Keypad speed ref: Drive auto-runs if digital input 1 is closed, depending on the P-802 setting.
7	Open: Stop (disable) Closed: Run (enable)	Open: Master speed ref Closed: Keypad speed ref	External trip input: Open: Trip Closed: Run	No effect	

Note that all parameters can be addressed by adding **40000** to the parameter number. For example, **parameter 201 (Input Mode)** can be addressed by Modbus address **40201**.

8.5 USER PI CONTROL MODE (P-201 = 5 OR 6)

Par. 721	Digital input 1 (T1)	Digital input 2 (T2)	Digital input 3 (T4)	Analog input (T6)	Comments
0, 2, 4, 5, 8...12	Open: Stop (disable) Closed: Run (enable)	Open: PI control Closed: Preset speed 1	PI feedback analog input	No effect	
1	Open: Stop (disable) Closed: Run (enable)	Open: PI control Closed: Analog input 1	PI feedback analog input	Analog input 1	
3, 6, 7*	Open: Stop (disable) Closed: Run (enable)	Open: PI control Closed: Preset speed 1	External trip input: Open: Trip Closed: Run	PI feedback analog input	Connect external thermistor type PT100 or similar to digital input 3

*** NOTES:** By default, the PI reference is set for a digital reference level set in **P-866**.
 When using an analog reference, set **P-869 = 1** (analog), and connect reference signal to analog input 1 (T6).
 The default settings for proportional gain **[P-852]**, integral gain **[P-853]**, and feedback mode **[P-850]** are suitable for most HVAC and pumping applications.
 The analog reference used for PI control can also be used as the local speed reference when **P-721 = 1**.

The following diagrams illustrate various applications where **parameter 201** (control mode selection) is set to **5** (user PI control mode), and the settings for **parameter 721** (digital input function select) are set for 0, 1, and 3, respectively:

8.5.1 Remote closed loop PI feedback control with local preset speed 1:

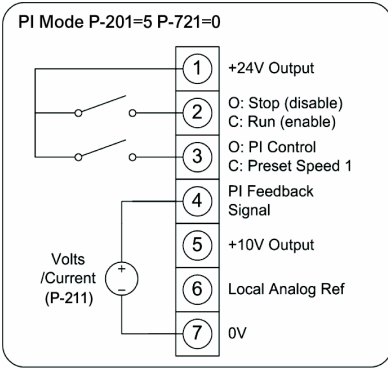

Parameter 201 is set to 5; Parameter 721 is set to 0.

8.5.2 Remote closed loop PI feedback control with local analog speed input:

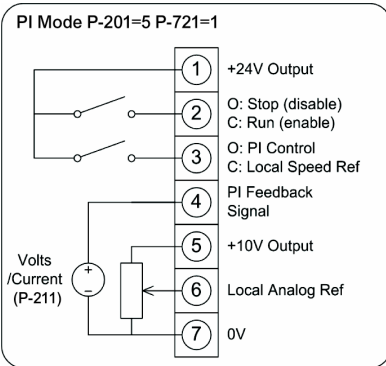

Parameter 201 is set to 5; Parameter 721 is set to 1.

8.5.3 Remote closed loop PI feedback control w/ local preset speed 1, motor thermistor trip:

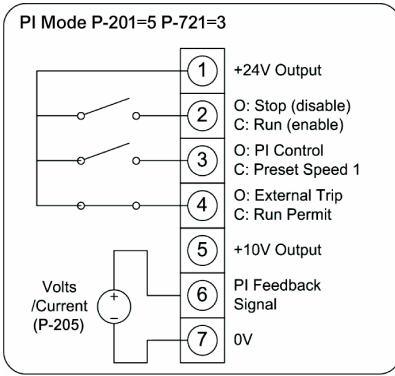

Parameter 201 is set to 5; Parameter 721 is set to 3.

9. TROUBLESHOOTING AND FAULT MESSAGES

This chapter provides the fault messages and codes for the SE2 drive, along with suggestions for corrective action.

If you need to contact technical support, the 24-hour support telephone number in the United States is +1 877-822-6606.

Fault messages

(Page 1 of 2)

Fault Code	Description	Corrective Action
P-dEF	Factory default parameters have been loaded	Press STOP key; drive is ready to configure for a particular application.
Q- I	Overcurrent on drive output. Excess load on the motor. Over-temperature on the drive heatsink.	Motor at constant speed; investigate overload or malfunction. Motor starting; load stalled or jammed. Check for star-delta motor wiring error. Motor accelerating/decelerating: the accel/ decel time too short, requiring too much power. If P-402 or P-403 cannot be increased, a bigger drive is required. Cable fault between drive and motor.
I- t- t r P	Drive has tripped on overload after delivering >100% of value in P-510 for a period of time.	Check to see when the decimal points are flashing (drive in overload) and either decrease acceleration rate or load. Check cable length to be sure it is within specifications range.
QI- b	Brake channel over current	Over current in the brake resistor circuit. Check the cabling to the brake resistor. Check brake resistor value. Ensure that minimum resistance values from the rating tables are observed.
QL- br	Brake resistor overload	Brake resistor overload. Increase deceleration time, reduce load inertia, or add further brake resistors in parallel. Ensure that minimum resistance values from the rating tables are observed.
P5- t r P	Internal power stage fault	Check wiring to motor, look for ph-ph or ph-ground short circuit. Check drive ambient temperature; is additional space or cooling needed? Check that drive is not forced into overload.
U- Uo It	Over voltage on DC bus	Supply problem, or increase decel ramp time with P-403 .
U- Uo It	Under voltage on DC bus	This occurs routinely when power is switched off. If it occurs during run operation, check the power supply voltage.
Q- t	Heatsink over temperature	Check drive ambient temperature. Additional space or cooling may be required.
U- t	Under temperature	Trip occurs when ambient temperature is less than 0 degrees C.
t h- F L t	Faulty thermistor on heatsink	Refer to an authorized Vacon distributor.

(Page 2 of 2)

Fault Code	Description	Corrective Action
E-trIP	External trip (on digital input 2 or 3)	E-trip requested on digital input 2 or 3. Normally closed contact has opened for some reason. If motor thermistor is connected, check to see if the motor is too hot.
SC-trP	Comms loss trip	Check communication link between drive and external devices. Make sure each drive in the network has a unique address.
P-LOSS	Input phase loss trip	Drive intended for use with a 3-phase supply has lost one input phase.
SPIN-F	Spin start failed	Spin start function failed to detect the motor speed.
dRtA-F	Internal memory fault	Parameters not saved; defaults reloaded. Try again. If problem recurs, contact an authorized Vacon distributor.
4-20 F	Analog input current out of range	Check input current in range defined by P-205 .
SC-FLt	Internal drive fault	Contact an authorized Vacon distributor.
FAULTY	Internal drive fault	Contact an authorized Vacon distributor.

10. TECHNICAL DATA

This chapter provides ratings and environmental information for the SE2 drives. Dimensional data and diagrams for the SE2 models are in [“Receiving and installation” on page 10.](#)

10.1 ENVIRONMENTAL INFORMATION

Operational ambient temperature range	0 - 50 degrees C
Storage ambient temperature range	-40 - 60 degrees C
Maximum altitude	2000 m. Derate above 1000 m: 1% / 100 m
Maximum humidity	95%, non-condensing

10.2 RATINGS

110-115V +/- 10% - 1 Phase Input - 3 Phase 230V Output (Voltage Doubler)

kW	HP	Frame size	Nominal input current (Amps)	Fuse or MCB (Type B) (Amps)	Nominal output current (Amps)	150% output current 60 s (Amps)	Max. motor cable length (m)	Min. brake res. value (Ohms)
0.37	0.5	1	6.7	10	2.3	3.45	25	-
0.75	1	1	12.5	16	4.3	6.45	25	-
1.1	1.5	2	16.8	20	5.8	8.7	100	47

200-240V +/- 10% - 1 Phase Input - 3 Phase Output

kW	HP	Frame size	Nominal input current (Amps)	Fuse or MCB (Type B) (Amps)	Nominal output current (Amps)	150% output curr. 60 s (Amps)	Max. motor cable length (m)	Min. brake res. value (Ohms)
0.37	0.5	1	6.7	6	2.3	3.45	25	-
0.75	1	1	12.5	10	4.3	6.45	25	-
1.5	2	1	19.3	20	7	10.5	25	-
1.5	2	2	19.3	20	7	10.5	100	47
2.2	3	2	28.8	32	10.5	15.75	100	47

(continued on next page)

200-240V +/- 10% - 3 Phase Input - 3 Phase Output

kW	HP	Frame size	Nominal input current (Amps)	Fuse or MCB (Type B) (Amps)	Nominal output current (Amps)	150% output curr. 60 s (Amps)	Max. motor cable length (m)	Min. brake res. value (Ohms)
1.5	2	2	9.2	16	7	10.5	100	47
2.2	3	2	13.7	20	10.5	15.75	100	47
4.0	5	3	20.7	32	18	27	100	47

380-480V +/- 10% - 3 Phase Input - 3 Phase Output

kW	HP	Frame size	Nominal input current (Amps)	Fuse or MCB (Type B) (Amps)	Nominal output current (Amps)	150% output current 60 s (Amps)	Max. motor cable length (m)	Min. brake res. value (Ohms)
0.75	1	1	2.9	5	2.2	3.3	25	-
1.5	2	1	5.4	10	4.1	6.15	25	-
1.5	2	2	5.4	10	4.1	6.15	50	100
2.2	3	2	7.6	10	5.8	8.7	50	100
4	5	2	12.4	16	9.5	14.25	50	100
5.5	7.5	3	17.6	20	14	21	100	22
7.5	10	3	22.1	25	18	27	100	22

10.3 MAXIMUM SUPPLY RATINGS FOR UL COMPLIANCE

Drive rating	Maximum supply voltage	Maximum supply short-circuit current
115V ratings: 0.37kW (0.5 HP) to 1.1kW (1.5 HP)	120V rms (AC)	5kA rms (AC)
230V ratings: 0.37kW (0.5 HP) to 3.7kW (5 HP)	240V rms (AC)	5kA rms (AC)
400/460V ratings: 0.75kW (1 HP) to 7.5 kW (10 HP)	500V rms (AC)	5kA rms (AC)

All the drives in the above chart are suitable for use on a circuit capable of delivering not more than these specified maximum short-circuit Amperes symmetrical with the specified maximum supply voltage.

Appendix A: Quick Start Guide for the SE2 Drive



Keypad and display information can be found in "Operation" on page 19

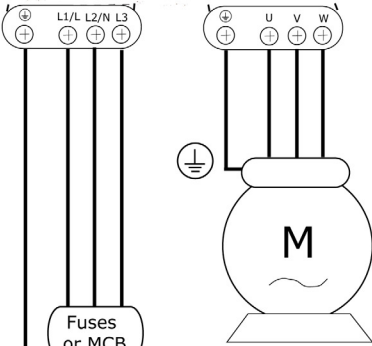
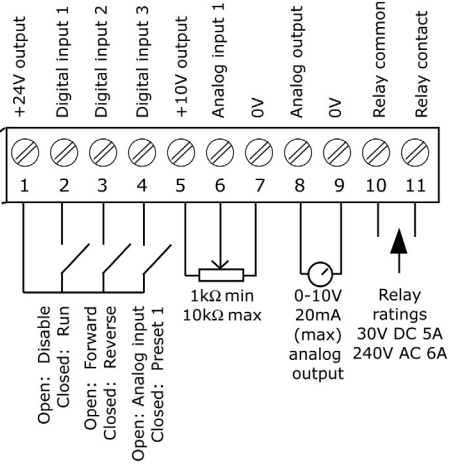

For **fuse** information, see page 40

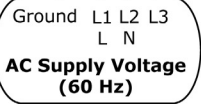

Motor nameplate:

Enter motor rated **voltage** (V) in **P-509**.
 Enter motor rated **current** (A) in **P-510**.
 Enter motor rated **frequency** (Hz) in **P-503**.

Control terminals:

- Based on default setting out of the box,
1. Connect a Start/Stop switch from Terminal 1 to 2
 2. Close the contact (start/enable the drive)
 3. Open the contact (stop the drive)
 4. Connect a 10kΩ potentiometer on terminals 5, 6 and 7 to vary the speed from 0..60 Hz

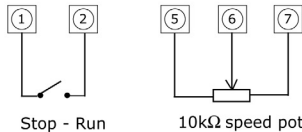

For **cable** information, refer to drive rating data in "Ratings" on page 40

Supply voltage:

- 115, 230, 460V
- 1 or 3 phase
- see drive rating information in "Ratings" on page 40

Motor connection: Ensure that the motor is connected for the proper voltage configuration that matches the SE2 drive's output rating.

VACON

DRIVEN BY DRIVES

Find your nearest Vacon office
on the Internet at:

www.vacon.com

