

# H6ECM

Split-core Current Switch, Proof of Rotation (Flow) for ECM Systems



H6ECM05



The H6ECM is a current-sensitive switching device that monitors current (amperage) in the conductor passing through it. A change in amperage in the monitored conductor that crosses the switch (setpoint) causes the resistance of the FET status output to change state, similar to the action of a mechanical switch. The status output is suitable for connection to building controllers or other appropriate data acquisition equipment operating at up to 30 V. The product requires no external power supply to generate its output.

Electrically Commutated Motors (ECMs) are increasingly common as more energy conservation measures are implemented. The ECM is a brushless DC motor that is supplied AC power, converts that power to DC current and uses electronic switching to control the motor rotation. The ECM motor shaft speed can be reduced to save energy, resulting in lower cost and less component wear. The H6ECM is optimized to provide meaningful proof of rotation which verifies that the ECM motor is operating as expected.

## SPECIFICATIONS

Sensor Power	Induced from the monitored conductor
Insulation Class	600 Vac RMS
Frequency Range	60 Hz
Temperature Range	-15 to 60 °C (5 to 140 °F)
Humidity Range	10 to 90% RH non-condensing
Hysteresis	10% typical
Accuracy	±10%
Amperage Range	0.5 to 175 A continuous
Status Output Ratings	N.O. 1.0A @ 30 Vac/dc, not polarity sensitive
Setpoint	0.5 A (keep alive current < 0.5 A)
Off State Resistance	Open switch represents > 1 MΩ
On State Resistance	Closed switch represents < 200 mΩ

## High performance

High performance device, split-core housing

## Precise

Precise current trip point setting

## Small size

Fits easily inside small enclosures

## Self-gripping iris

Self-gripping iris for easy installation

## Status LEDs

Status LEDs for easy setup and local indication

## Up to 1 Amp status output

Increased application flexibility

## APPLICATIONS

- Systems with Electrically Commutated Motors such as cooling fans or compressor motors with off-state (keep alive) current less than 0.5 A

Terminal Block Max. Wire Size	24 to 14 AWG (0.2 to 2.1mm <sup>2</sup> )
Terminal Block Torque	3.5 to 4.4 in-lbs (0.4 to 0.5 N-m)

## WARRANTY

Limited Warranty	5 years
------------------	---------

## AGENCY APPROVALS

Agency Approvals	UL508 open device listing
Installation Category	CAT III, Pollution Degree 2



Notes: For applications requiring double or reinforced insulation, please contact the factory. The product design provides basic insulation only. Do not use the LED indicators as evidence of applied voltage.



**DIMENSIONAL DRAWING**

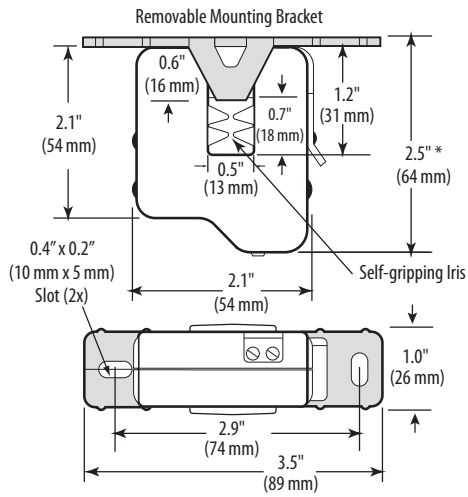

\* Terminal block may extend up to 1/8" over the height dimensions shown.

**WIRING DIAGRAM**

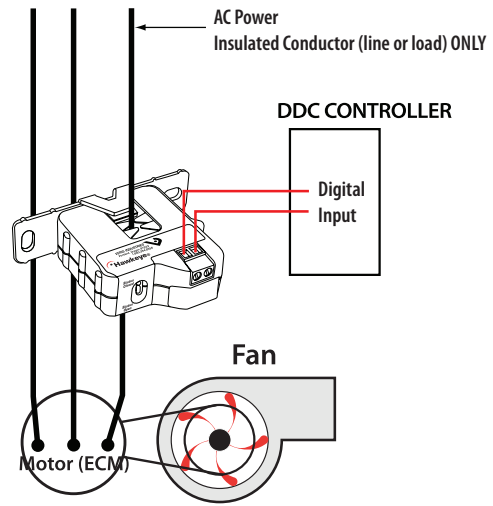

**ORDERING INFORMATION**

MODEL	AMPERAGE RANGE	STATUS OUTPUT	TRIP POINT	STATUS LED	UL
H6ECM05	0.5 to 175 A	N.O. 1.0 A @ 30 Vac/dc	0.5 A	•	•

