

# Controls

## IEC Contactors - CWM Series

### Mechanical Drawings

#### CWM9, CWM12 and CWM18

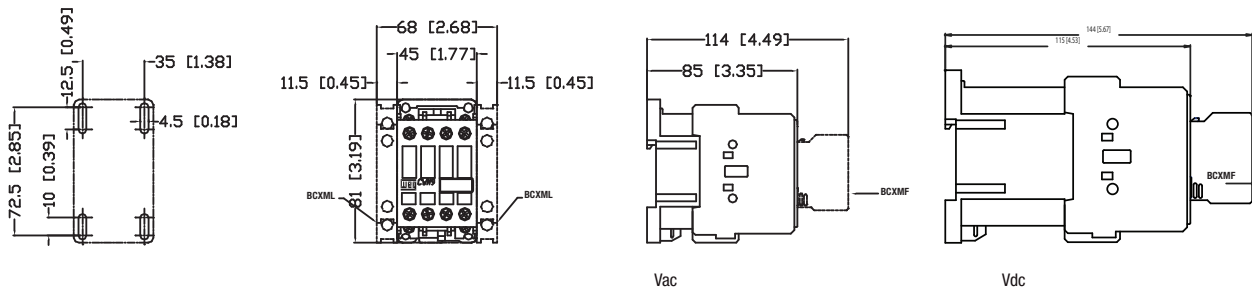

#### CWM25

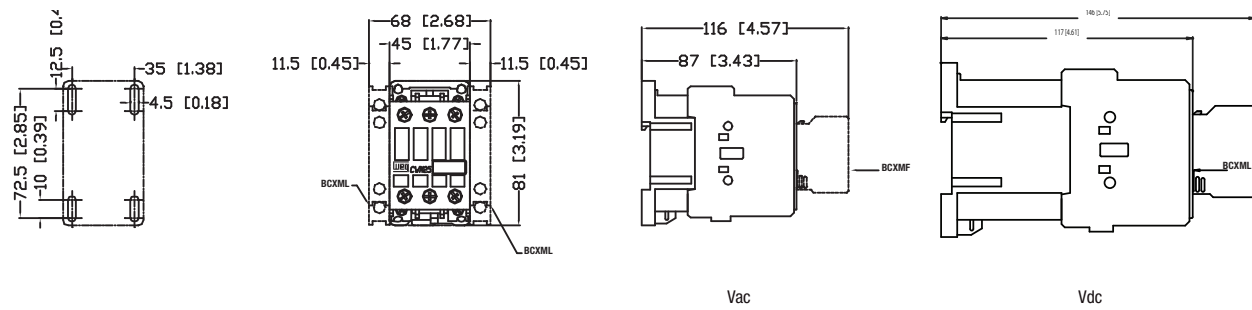

#### CWM32 and CWM40

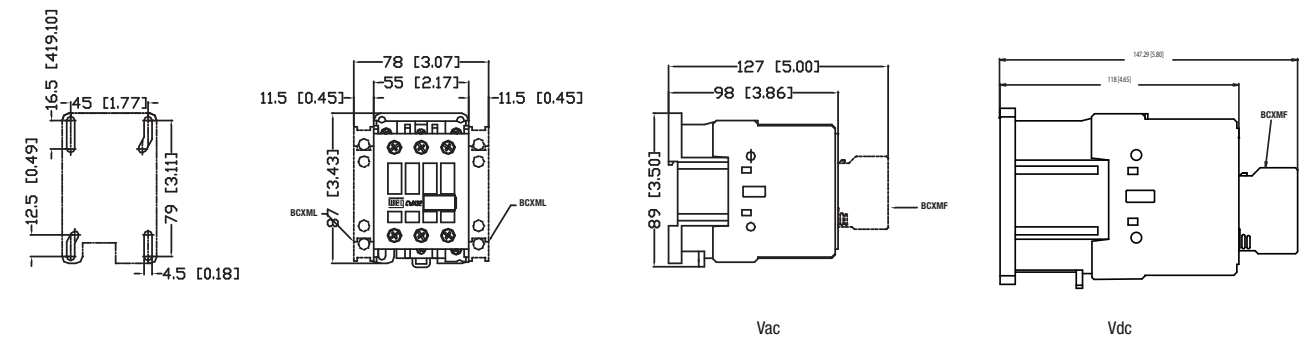



# Controls IEC Contactors - CWM Series

## Mechanical Drawings

### CWM50, CWM65 and CWM80

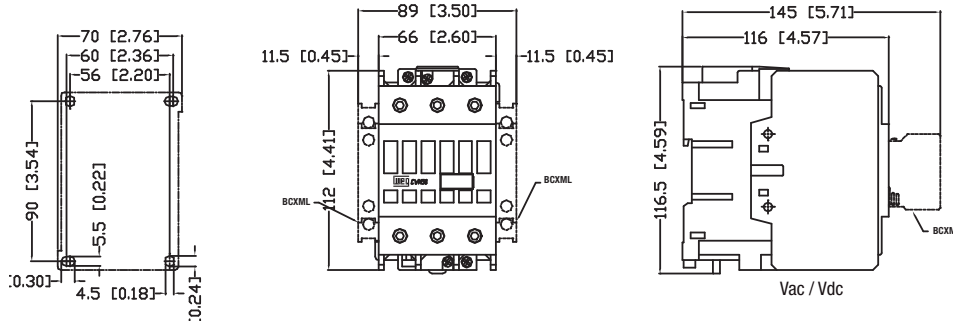

### CWM95 and CWM105

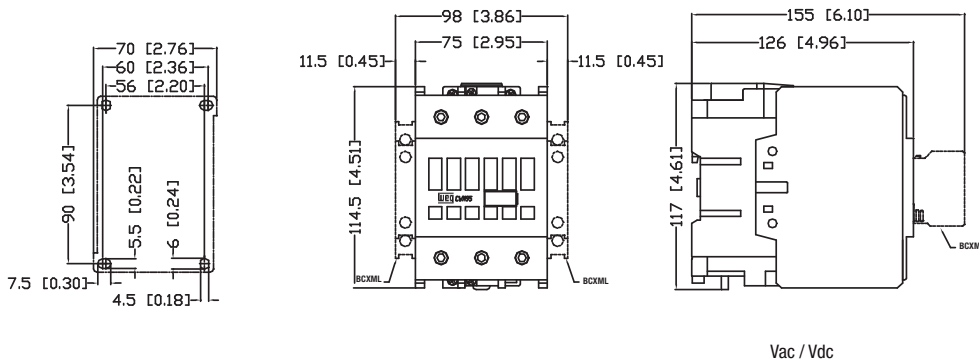

# Controls

## IEC Contactors - CWM Series

### Mechanical Drawings

#### CWM112 and CWM150

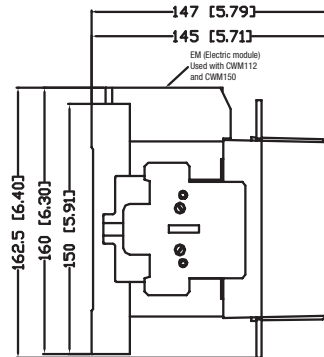
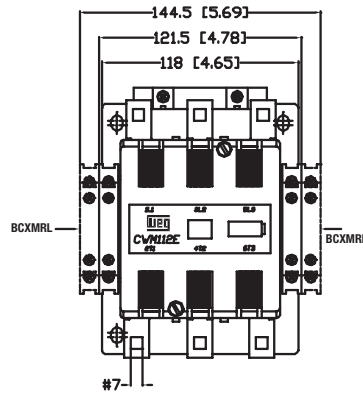
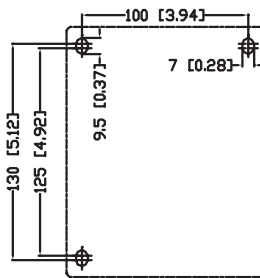

#### CWM180

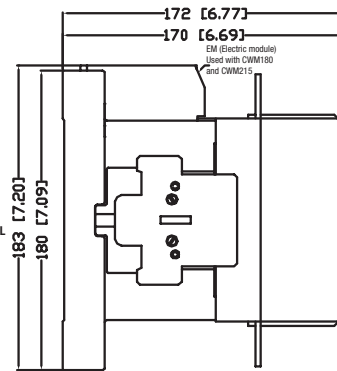
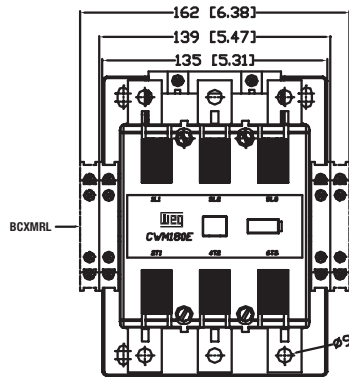
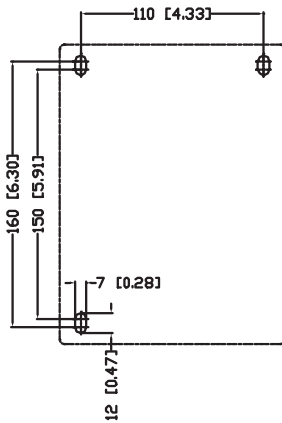

#### CWM250 and CWM300

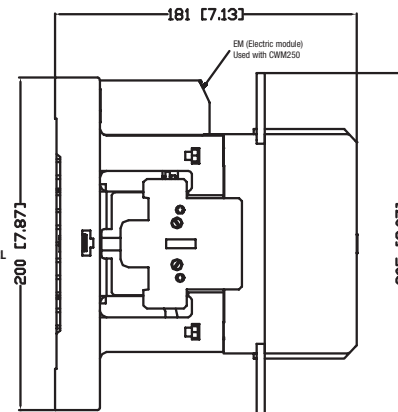
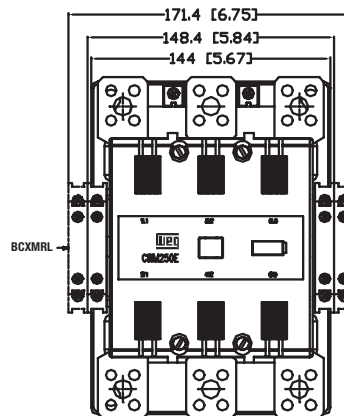
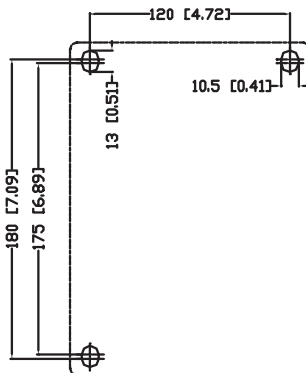

\*Contact WEG for larger sizes.



# Controls

## IEC Contactors - CWM & CWME Series

### Mechanical Drawings

#### CWME400

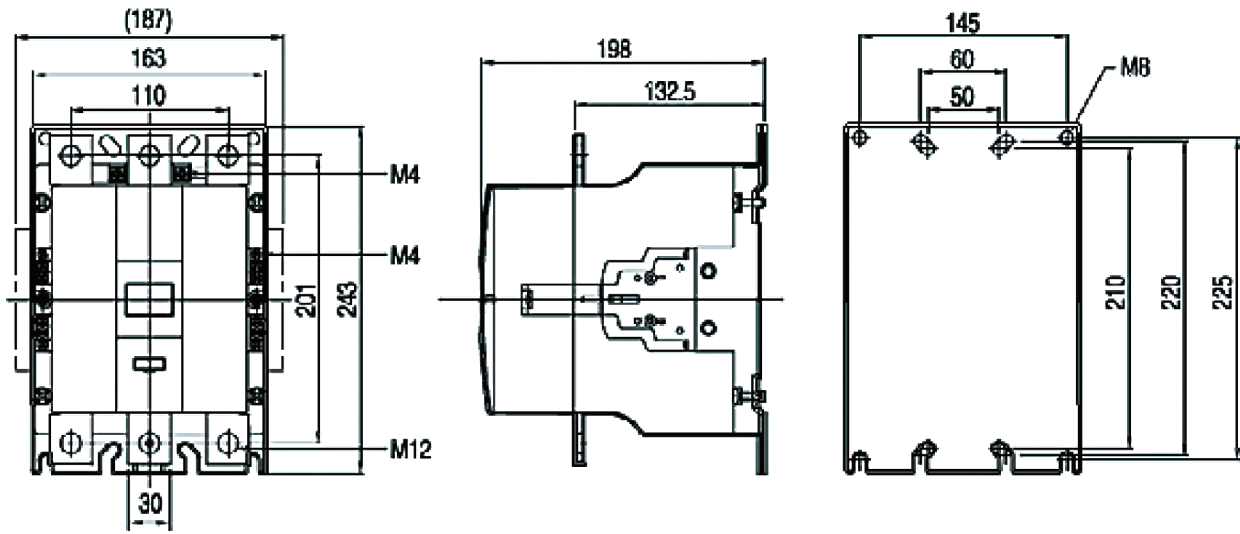

#### CWME630/CWME800

