

Solid-State Relay Module

857 Series

2

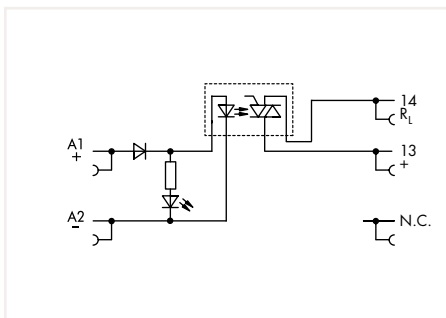

Solid-State Relay Module; Output voltage range: 24 ... 240 VAC; Limiting continuous current: 2 A; 2-wire connection; Zero-voltage switching; Status indicator: yellow; 6 mm wide

U_N	I_N	Item No.	Pack. Unit
24 VDC	9.2 mA	857-714	25

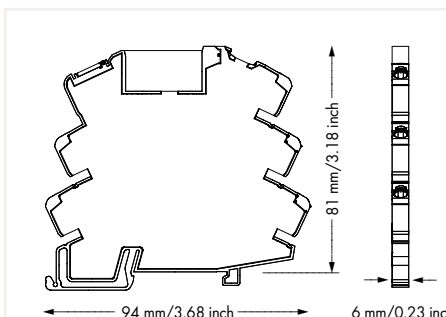

Note:
Optocouplers and solid-state relays are designed for use in signal processing networks that are not supplied by the low-voltage power grid.

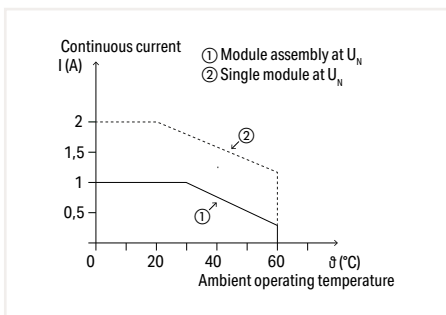

Current-Carrying Capacity Curve

Control Circuit

Input voltage range (low level)	0 ... 10 VDC
Input voltage range (high level)	20 ... 28.8 VDC

Load Circuit

Circuit type	2-wire connection; zero-voltage switching
Limiting continuous current	2 A
Output voltage range	24 ... 240 VAC
Voltage drop (output) max.	≤ 1.6 VAC
Leakage current at rated voltage	≤ 1.5 mA
Switching current (min.)	22 mA
Turn-on time	≤ 10 ms
Turn-off time	≤ 10 ms
Mains frequency	50 Hz / 60 Hz

Signaling

Status indicator	Yellow LED
------------------	------------

Safety and Protection

Dielectric strength, control/load circuit (AC, 1 min)	3.75 kV _{rms}
Protection type	IP20

Connection Data

Connection technology	Push-in CAGE CLAMP®
Solid conductor	0.34 ... 2.5 mm ² / 22 ... 14 AWG
Fine-stranded conductor	0.34 ... 2.5 mm ² / 22 ... 14 AWG
Strip Length	9 ... 10 mm / 0.35 ... 0.39 inch

Physical Data

Width	6 mm / 0.236 inch
Height from upper-edge of DIN-rail	81 mm / 3.189 inch
Depth	94 mm / 3.701 inch

Mechanical Data

Mounting type	DIN-35 rail
---------------	-------------

Material Data

Weight	28.4 g
--------	--------

Environmental Requirements

Surrounding air temperature (operation at U_N)	-20 ... +60 °C
Surrounding air temperature (storage)	-40 ... +70 °C
Processing temperature	-25 ... +50 °C

Standards and Specifications

Standards/specifications	EN 61000-6-2; EN 61000-6-3; EN 61373; EN 61010-2-201; UL 508
--------------------------	--