

1. For your safety

The light has been designed in accordance with state-of-the-art standards, manufactured with utmost care using high-quality materials, and tested.

Nevertheless, its use may constitute a risk to persons or cause material damage.



- ▶ Read all enclosed instructions and information.
- ▶ Please observe the warnings included in the documentation and attached to the unit.
- ▶ The device must only be used in technically perfect condition, and only by persons being aware of the risks and dangers involved in operating the device.
- ▶ Keep this document available near the device.

1.1 Designated use

The light with integrated magnifier is intended for the illumination and simultaneous magnification of objects.

1.2 Safety instructions

Explosion hazard

Operating the light in rooms subject to explosion hazards can trigger an explosion and result in serious injuries or death.

- ▶ **Do not** operate the light in rooms subject to explosion hazards.

Danger due to electric current

Improper use and faulty work on the light may result in injuries and material damage.

- ▶ Compare the mains voltage with the nominal voltage and the frequency specified on the rating plate and make sure that they are identical.
- ▶ Disconnect the damaged connecting cable immediately from the power supply and have it replaced by the manufacturer or by a qualified electrician.
- ▶ Have maintenance and repair work carried out by a trained electrician only.
- ▶ Before performing work on the light, disconnect the light from the power supply.

Risk of fire

When exposed to sunlight, the magnifier can act as a focusing glass and ignite other objects.

- ▶ When the magnifier is not used, cover it with the magnifier cover.

Mount the light in a stable position

A toppling light can result in personal injuries and material damage.

- ▶ Mount the light in a stable position.

Hazard caused by unsuitable spare parts

Unsuitable spare parts can result in injuries and material damage.

- ▶ Only spare parts released by the manufacturer may be used as spare parts.

Risk of corrosion

Operating the light in moist rooms can result in material damage.

- ▶ Operate in dry rooms only.

1.3 Warning levels

DANGER

Warnings against hazards that result **directly in serious injuries or death** in case of non-observance.

WARNING

Warnings against hazards that may result in **serious injuries or death** in case of non-observance.

CAUTION

Warning against hazards that may result in **injuries** in case of non-observance.

NOTICE

Warning against hazards that may result in **material damage** in case of non-observance.

2. Model overview

For optimum installation and use of the light, you have to identify the light model unambiguously. To do so, you will require the model number of the light.

NOTE: The model number can be found on the support of the light.

- ▶ Check which model number the light has.
- ▶ Determine the light model by referring to the following table, see Tab. 1. For an explanation of the functions, see chapter 6 "Functions of the light", page 23.

Example: The model number **RLLQ 48/2 R** stands for the following light model:

RLLQ	48	2 R
TEVISIO Magnifier luminaire	48 LEDs	Version 2 R Functions: <ul style="list-style-type: none"> ▪ Switchable ▪ Dimmable ▪ Light segments

Type	Number of LEDs	Version	Functions
RLLQ TEVISIO Magnifier luminaire	48	R	Switchable Dimmable
		2 R	Switchable Dimmable Light segments

Tab. 1: Model overview.

3. Mounting

⚠ CAUTION

Risk of injury caused by a falling or tilting light.

Personal injury and material damage.

- ▶ Mount fastening elements correctly.

3.1 Mounting the fastening elements

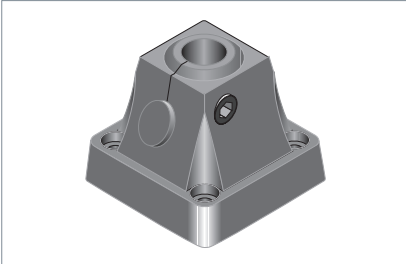

Fig. 1: Fastening element, screw-type fastening.

- ▶ Screw the fastening element to the mounting surface using four suitable screws.

3.2 Mounting the light to the fastening element

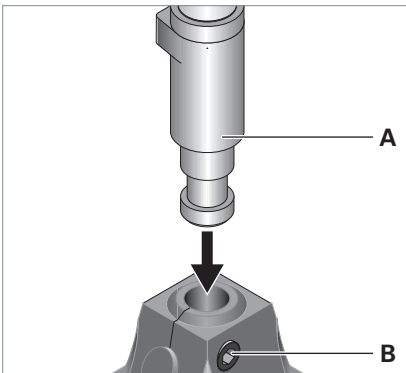

Fig. 2: Mounting the light to the fastening element.

NOTE: The screw **B** on the side of the fastening element can be used to make the opening of the fastening element larger or smaller.

- ▶ Insert the stud **A** on the light support into the opening of the fastening element, see Fig. 2.
- ▶ Tighten the screw **B** to fix the support, see Fig. 2.

3.3 Mounting the magnifier cover

⚠ CAUTION

Fire risk when the magnifier is not covered and exposed to sunlight.

Personal injury and material damage.

- ▶ When the magnifier is not used, cover it with the magnifier cover.

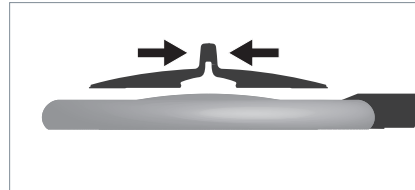

Fig. 3: Mounting the magnifier cover.

- ▶ Compress the upper part of the magnifier cover, see Fig. 3.
- ▶ Place the magnifier cover on the magnifier from above and release the cover. The magnifier cover is clamped to the light head.

3.4 Storing the magnifier cover

While using the magnifier, you can store the magnifier cover on the light support.

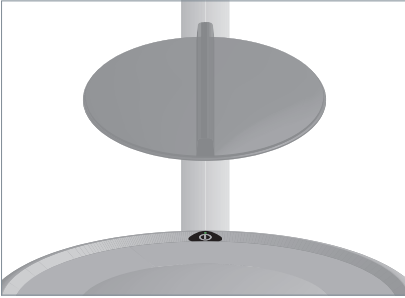

Fig. 4: Storing the magnifier cover.

- ▶ Clamp the magnifier cover to the light support, see Fig. 4.

4. Positioning

4.1 Adjusting the support

CAUTION

Risk of injury caused by a falling or tilting light.

Personal injury and material damage.

- ▶ Hold the light head when unscrewing the pivot screws.
- ▶ After positioning the support, tighten the pivot screws.

NOTICE

Material damage caused by wrong handling.

Damage to the light.

- ▶ Do **not** move the joints opposite to the intended direction of rotation.

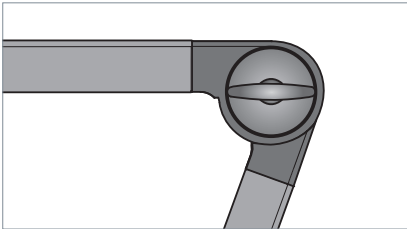

Fig. 5: Joint and pivot screw.

- ▶ Place the light in the desired position.
- ▶ Tighten the pivot screw until the light is fixed in the desired position.

5. Connection

NOTICE

Material damage caused by wrong mains voltage.

Damage or destruction of the light.

- ▶ Check whether the mains voltage matches the nominal voltage and the frequency specified on the rating plate and make sure that they match.

5.1 Connecting the light to the power supply

- ▶ Plug the plug-in power supply unit into a socket.

6. Functions of the light

Depending on the light model, the light has different functions. If you want to find out which functions the light has, see chapter 2 "Model overview," page 19.

6.1 Operating functions

Switchable

This function can be used to switch the light on and off.

Dimmable

This function is used to change the brightness of the light.

Light segments

This function can be used to switch the individual light segments on and off.

The light segments create a 3D shadow effect which highlights the structure and reveals slight defects or fine differences in the surface structure of an object.

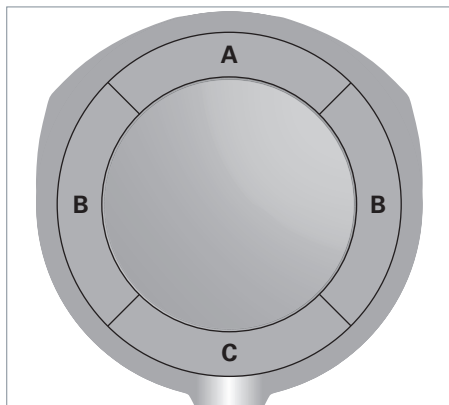

Fig. 6: Light segments.

Level	Description
1	Light segments A+B+C are lit.
2	Light segments B are lit.
3	Light segment C is lit.

7. Operation



Fig. 7: Switch.

7.1 Switch-on and switch-off

- ▶ Press the switch, see Fig. 7.

7.2 Dimming

- ▶ Press the switch and keep it depressed, see Fig. 7.

After about one second, the light will change its brightness.

As soon as the maximum or minimum dimming value is reached, the LED in the switch will flash.

- ▶ To change the dimming direction, press the switch again and keep it depressed.

This will save the set brightness. The next time the light is switched on, the brightness saved last will be set.

7.3 Changing the light segments

- ▶ Press the switch twice in quick succession, see Fig. 7.

The next level is switched on.

The set level is saved. The next time the light is switched on, the level saved last will be set automatically.

8. What to do if?

Problem	Possible causes	Corrective action
Light is not lit.	Mains plug not plugged in.	▶ Plug the mains plug into a socket.
	LED module is defective.	▶ Contact our experts.
The light switches off automatically.	The temperature in the light head is too high.	▶ No measures required. As soon as the temperature in the light head has decreased, the light can be switched on again.
Light does not respond to inputs.	Software function is defective.	▶ Unplug the mains plug for a few seconds.
		▶ If the light still doesn't respond, contact our experts.
The connecting cable is damaged.	Mechanical impact on the connecting cable.	▶ Disconnect the damaged connecting cable immediately from the power supply and have it replaced by the manufacturer or by a qualified electrician.

Tab. 2: What to do if?

9. Replacing the lamp

NOTE: The light is maintenance-free. A lamp replacement is not required.

10. Cleaning



WARNING

Danger of death due to electric shock.

- ▶ Disconnect the light from the mains.
- ▶ **Do not** clean with a wet cloth.

NOTICE

Material damage caused by using wrong cleaning agents.

Damage to the light.

- ▶ Make sure the cleaning agent is compatible with the surface.
- ▶ Clean the light with a cloth and a mild detergent.

11. Repair

NOTICE

Material damage caused by improper repair.

Damage or destruction of the light.

- ▶ Have repairs performed only by the manufacturer or skilled personnel trained by the manufacturer.
- ▶ Only spare parts released by the manufacturer may be used as spare parts.

12. Disposal



The light is subject to European Directive 2002/96/EC.

- ▶ Dispose of the light separately from domestic waste using the agencies responsible for disposal and designated by the authorities.

Proper disposal avoids adverse effects on man and the environment.

13. Technical data

NOTE: The data given on the rating plate attached to the support of the light apply.

13.1 Dimensions

Designation	Value
Light head	Diameter: 265 mm Height: 21 mm
Length	Short version: 400 + 384 + 372 mm Long version: 500 + 484 + 372 mm

Tab. 3: Dimensions TEVISIO.

13.2 Electrical values

Designation	Value
Voltage range	100-240 V AC
Frequency range	50/60 Hz
Power consumption	Max. 14 W
Equipped with	48 LEDs
Operating unit	Plug-in power supply unit

Tab. 4: Electrical values TEVISIO.

13.3 Classifications

Designation	Value
Protection class	II
Protection type	IP 20
Operating mode	Continuous operation
Technical safety check	EN 60598-1





Tab. 5: Classifications TEVISIO.

13.4 Magnifier data

Designation	Value
Diameter	160 mm (153 mm visible)
Strength	Without stuck on add-on lens: 3.5 dioptres With stuck on add-on lens: 11.5 dioptres

Tab. 6: Magnifier data TEVISIO.

13.5 Symbols

Symbol	Designation
	Protection class II Operation with protective insulation
	Suitable for mounting on normally inflammable surfaces
	CE conformity mark
	Disposal in accordance with European Directive 2002/96/EC

Tab. 7: Symbols.