



HW-141206CHSC

Construction

- Fiberglass construction
- Poured polyurethane seamless gasket provides watertight, dust-tight environmental seal
- Excellent chemical and corrosion resistance
- Rounded edges, minimal protrusions or exposed pocket area for accumulation of dust or debris
- 300 Series stainless steel used on all external hardware
- **Optional** mounting foot kit available
- Opaque, hinged cover with two screws.
- Raised bosses with brass inserts accepting 10-32 screws for optional panel mounting
- Impact resistance and physical strength greater than that of ABS and PVC
- Full 180° door opening
- Color: Gray

Listings

- UL/cUL 50/508, Types 1, 3, 3S, 12, 13, 4x
- UL File E64791
- CSA Standard C22.2 File 222873 Types 1, 3, 3S, 12, 13, 4x
- NEMA Standard 250 Types 1, 3, 3S, 12, 13, 4x
- IEC 60529 IP66
- UL94 V-0, 5V flammability rating
- Non-flame propagating
- Flame Spread classification per NFPA No. 101, Class A (1)
- Temperature Range: -40°F to 250°F (-40°C to 120°C)



Premier Series Non-Metallic Enclosures - Opaque Cover, Hinged with Two Cover Screws							
Part Number	Enclosure Overall Size HxWxD	Enclosure Inside AxBxC	Wt.	Carbon Steel Subpanel*	Fiberglass Subpanel*	Stainless Steel Subpanel*	Aluminum Subpanel*
HW-60604CHSC	7.41 x 7.79 x 4.31 (188.3 x 197.9 x 109.5)	6.77 x 6.77 x 4.06 (171.9 x 171.9 x 103.2)	2.5 lbs	HW-MP606CS	HW-MP606FG	HW-MP606SS	HW-MP606A
HW-80604CHSC	9.41 x 7.79 x 4.31 (239.1x197.9x109.5)	8.77 x 6.77 x 4.06 (222.7 x 171.9 x 103.2)	3.0 lbs	HW-MP806CS	HW-MP806FG	HW-MP806SS	HW-MP806A
HW-80804CHSC	9.39 x 9.76 x 4.31 (238.5 x 248.0 x 109.5)	8.74 x 8.74 x 4.06 (222.1 x 222.1 x 103.2)	3.5 lbs	HW-MP808CS	HW-MP808FG	HW-MP808SS	HW-MP808A
HW-100806CHSC	11.42 x 9.79 x 6.31 (290.1 x 248.6 x 160.3)	10.73 x 8.73 x 6.06 (272.5 x 221.7 x 153.9)	4.5 lbs	HW-MP1008CS	HW-MP1008FG	HW-MP1008SS	HW-MP1008A
HW-121006CHSC	13.45 x 11.83 x 6.31 (341.6 x 300.5 x 160.3)	12.69 x 10.69 x 6.06 (322.3 x 271.5 x 153.9)	6.0 lbs	HW-MP1210CS	HW-MP1210FG	HW-MP1210SS	HW-MP1210A
HW-141206CHSC	15.49 x 13.86 x 6.31 (393.4 x 352.0 x 160.3)	14.72 x 12.72 x 6.06 (373.9 x 323.1 x 153.9)	8.0 lbs	HW-MP1412CS	HW-MP1412FG	HW-MP1412SS	HW-MP1412A
HW-141208CHSC	15.49 x 13.86 x 8.34 (393.4 x 352.0 x 211.8)	14.66 x 12.66 x 8.06 (372.4 x 321.6 x 204.7)	9.5 lbs	HW-MP1412CS	HW-MP1412FG	HW-MP1412SS	HW-MP1412A
HW-161408CHSC	17.58 x 15.96 x 8.34 (446.6 x 405.4 x 211.8)	16.69 x 14.69 x 8.06 (424.0 x 373.1 x 204.7)	11.5 lbs	HW-MP1614CS	HW-MP1614FG	HW-MP1614SS	HW-MP1614A
HW-181610CHSC	19.77 x 18.15 x 10.34 (502.2 x 461.0 x 262.6)	18.63 x 16.63 x 10.06 (473.2 x 422.4 x 255.5)	16.0 lbs	HW-MP1816CS	HW-MP1816FG	HW-MP1816SS	HW-MP1816A
HW-201610CHSC	21.79 x 18.16 x 10.34 (553.5 x 461.2 x 262.6)	20.63 x 16.63 x 10.06 (524.0 x 422.4 x 255.5)	17.5 lbs	HW-MP2016CS	HW-MP2016FG	HW-MP2016SS	HW-MP2016A

Dimensions in inches (millimeters). (See dimensional drawings on page 6 of this section.)

*Note: Subpanels must be ordered separately. See pages 26-28 for more information.





HW-141208CHQR

Construction

- Fiberglass construction
- Impact resistance and physical strength greater than that of ABS and PVC
- Poured polyurethane seamless gasket provides watertight, dust-tight environmental seal
- Opaque hinged cover with two pull latches
- Padlock latch for quick entry
- Integral hasp provides secure loop for padlock (padlock not included)
- Full 180° door opening
- UV resistant
- Excellent chemical and corrosion resistance
- Rounded edges, minimal protrusions or exposed pocket area for accumulation of dust or debris
- 300 Series stainless steel used on all external hardware
- **Optional** mounting foot kit available
- Raised bosses with brass inserts accepting 10-32 screws for optional panel mounting
- Color: Gray

Listings

- UL/cUL 50/508, Types 1, 3, 3S, 12, 13, 4x
- UL File E64791
- CSA Standard C22.2 File 222873 Types 1, 3, 3S, 12, 13, 4x
- NEMA Standard 250 Types 1, 3, 3S, 12, 13, 4x
- IEC 60529 IP66
- UL94 V-0, 5V flammability rating
- Non-flame propagating
- Flame Spread classification per NFPA No. 101, Class A (1)
- Temperature Range: -40°F to 250°F (-40°C to 120°C)



Premier Series Non-Metallic Enclosures - Opaque, Hinged Cover with Two Pull Latches							
Part Number	Enclosure Overall Size HxWxD	Enclosure Inside AxBxC	Wt.	Carbon Steel Subpanel*	Fiberglass Subpanel*	Stainless Steel Subpanel*	Aluminum Subpanel*
HW-60604CHQR	7.41 x 7.79 x 4.31 (188.3 x 197.9 x 109.5)	6.77 x 6.77 x 4.06 (171.9 x 171.9 x 103.2)	2.5 lbs	HW-MP606CS	HW-MP606FG	HW-MP606SS	HW-MP606A
HW-80604CHQR	9.41 x 7.79 x 4.31 (239.1 x 197.9 x 109.5)	8.77 x 6.77 x 4.06 (222.7 x 171.9 x 103.2)	3.0 lbs	HW-MP806CS	HW-MP806FG	HW-MP806SS	HW-MP806A
HW-80804CHQR	9.39 x 9.76 x 4.31 (238.5 x 248.0 x 109.5)	8.74 x 8.74 x 4.06 (222.1 x 222.1 x 103.2)	3.5 lbs	HW-MP808CS	HW-MP808FG	HW-MP808SS	HW-MP808A
HW-100806CHQR	11.42 x 9.79 x 6.31 (290.1 x 248.6 x 160.3)	10.73 x 8.73 x 6.06 (272.5 x 221.7 x 153.9)	4.5 lbs	HW-MP1008CS	HW-MP1008FG	HW-MP1008SS	HW-MP1008A
HW-121006CHQR	13.45 x 11.83 x 6.31 (341.6 x 300.5 x 160.3)	12.69 x 10.69 x 6.06 (322.3 x 271.5 x 153.9)	6.0 lbs	HW-MP1210CS	HW-MP1210FG	HW-MP1210SS	HW-MP1210A
HW-141206CHQR	15.49 x 13.86 x 6.31 (393.4 x 352.0 x 160.3)	14.72 x 12.72 x 6.06 (373.9 x 323.1 x 153.9)	8.0 lbs	HW-MP1412CS	HW-MP1412FG	HW-MP1412SS	HW-MP1412A
HW-141208CHQR	15.49 x 13.86 x 8.34 (393.4 x 352.0 x 211.8)	14.66 x 12.66 x 8.06 (372.4 x 321.6 x 204.7)	9.5 lbs	HW-MP1412CS	HW-MP1412FG	HW-MP1412SS	HW-MP1412A
HW-161408CHQR	17.58 x 15.96 x 8.34 (446.6 x 405.4 x 211.8)	16.69 x 14.69 x 8.06 (424.0 x 373.1 x 204.7)	11.5 lbs	HW-MP1614CS	HW-MP1614FG	HW-MP1614SS	HW-MP1614A
HW-181610CHQR	19.77 x 18.15 x 10.34 (502.2 x 461.0 x 262.6)	18.63 x 16.63 x 10.06 (473.2 x 422.4 x 255.5)	16.0 lbs	HW-MP1816CS	HW-MP1816FG	HW-MP1816SS	HW-MP1816A
HW-201610CHQR	21.79 x 18.16 x 10.34 (553.5 x 461.2 x 262.6)	20.63 x 16.63 x 10.06 (524.0 x 422.4 x 255.5)	17.5 lbs	HW-MP2016CS	HW-MP2016FG	HW-MP2016SS	HW-MP2016A

Dimensions in inches (millimeters). (See dimensional drawings on page 6 of this section.)

*Note: Subpanels must be ordered separately. See pages 26-28 for more information.



Premier Series – Non-Metallic Enclosures

Clear, Hinged Cover with Two Pull Latches



HW-CC141206CHQR

Construction

- Fiberglass construction
- Poured polyurethane seamless gasket provides watertight, dust-tight environmental seal
- Clear hinged cover with two pull latches
- UV resistant
- Clear cover rated UL94 V-2, HB.
- Excellent chemical and corrosion resistance
- Rounded edges, minimal protrusions or exposed pocket areas for accumulation of dust or debris
- 300 Series stainless steel used on all external hardware
- **Optional** mounting foot kit available
- Raised bosses with brass inserts accepting 10-32 screws for optional panel mounting
- Impact resistance and physical strength greater than that of ABS and PVC
- Full 180° door opening
- Integral hasp provides secure loop for padlock (padlock not included)
- Color: Gray

Listings

- UL/cUL 50/508, Types 1, 3, 3S, 12, 13, 4x
- UL File E64791
- CSA Standard C22.2 File 222873 Types 1, 3, 3S, 12, 13, 4x
- NEMA Standard 250 Types 1, 3, 3S, 12, 13, 4x
- IEC 60529 IP66
- UL94 V-0, 5V flammability rating
- Window flammability rating: UL94V-2, HB
- Non-flame propagating
- Flame Spread classification per NFPA No. 101, Class A (1)
- Temperature Range: -40°F to 250°F (-40°C to 120°C)



Premier Series Non-Metallic Enclosures - Clear Cover, Hinged with Two Pull Latches

Part Number	Enclosure Overall Size HxWxD	Enclosure Inside AxBxC	Wt.	Carbon Steel Subpanel*	Fiberglass Subpanel*	Stainless Steel Subpanel*	Aluminum Subpanel*
HW-CC60604CHQR	7.41 x 7.79 x 4.31 (188.3 x 197.9 x 109.5)	6.77 x 6.77 x 4.06 (171.9 x 171.9 x 103.2)	2.5 lbs	HW-MP606CS	HW-MP606FG	HW-MP606SS	HW-MP606A
HW-CC80604CHQR	9.41 x 7.79 x 4.31 (239.1 x 197.9 x 109.5)	8.77 x 6.77 x 4.06 (222.7 x 171.9 x 103.2)	3.0 lbs	HW-MP806CS	HW-MP806FG	HW-MP806SS	HW-MP806A
HW-CC80804CHQR	9.39 x 9.76 x 4.31 (238.5 x 248.0 x 109.5)	8.74 x 8.74 x 4.06 (222.1 x 222.1 x 103.2)	3.5 lbs	HW-MP808CS	HW-MP808FG	HW-MP808SS	HW-MP808A
HW-CC100806CHQR	11.42 x 9.79 x 6.31 (290.1 x 248.6 x 160.3)	10.73 x 8.73 x 6.06 (272.5 x 221.7 x 153.9)	4.5 lbs	HW-MP1008CS	HW-MP1008FG	HW-MP1008SS	HW-MP1008A
HW-CC121006CHQR	13.45 x 11.83 x 6.31 (341.6 x 300.5 x 160.3)	12.69 x 10.69 x 6.06 (322.3 x 271.5 x 153.9)	6.0 lbs	HW-MP1210CS	HW-MP1210FG	HW-MP1210SS	HW-MP1210A
HW-CC141206CHQR	15.49 x 13.86 x 6.31 (393.4 x 352.0 x 160.3)	14.72 x 12.72 x 6.06 (373.9 x 323.1 x 153.9)	8.0 lbs	HW-MP1412CS	HW-MP1412FG	HW-MP1412SS	HW-MP1412A
HW-CC141208CHQR	15.49 x 13.86 x 8.34 (393.4 x 352.0 x 211.8)	14.66 x 12.66 x 8.06 (372.4 x 321.6 x 204.7)	9.5 lbs	HW-MP1412CS	HW-MP1412FG	HW-MP1412SS	HW-MP1412A
HW-CC161408CHQR	17.58 x 15.96 x 8.34 (446.6 x 405.4 x 211.8)	16.69 x 14.69 x 8.06 (424.0 x 373.1 x 204.7)	11.5 lbs	HW-MP1614CS	HW-MP1614FG	HW-MP1614SS	HW-MP1614A

Dimensions in inches (millimeters). (See dimensional drawings on page 6 of this section.)

*Note: Subpanels must be ordered separately. See pages 26-28 for more information.



WIEGMANN

DATA SUBJECT TO CHANGE WITHOUT NOTICE



HW-CC141206CHTL

Construction

- Fiberglass construction
- Poured polyurethane seamless gasket provides watertight, dust-tight environmental seal
- Clear hinged cover with two link-lock latches
- UV resistant
- Clear cover rated UL94 V-2, HB.
- Excellent chemical and corrosion resistance
- Rounded edges, minimal protrusions or exposed pocket areas for accumulation of dust or debris
- 300 Series stainless steel used on all external hardware
- **Optional** mounting foot kit available
- Raised bosses with brass inserts accepting 10-32 screws for optional panel mounting
- Impact resistance and physical strength greater than that of ABS and PVC
- Full 180° door opening
- Link lock latch for quick entry
- Latch lies flat on side of enclosure
- Color: Gray

Listings

- UL/cUL 50/508, Types 1, 3, 3S, 12, 13, 4x
- UL File E64791
- CSA Standard C22.2 File 222873 Types 1, 3, 3S, 12, 13, 4x
- NEMA Standard 250 Types 1, 3, 3S, 12, 13, 4x
- IEC 60529 IP66
- UL94 V-0, 5V flammability rating
- Window flammability: UL94V-2, HB
- Non-flame propagating
- Flame Spread classification per NFPA No. 101, Class A (1)
- Temperature Range: -40°F to 250°F (-40°C to 120°C)



Premier Series Non-Metallic Enclosures - Clear Cover, Hinged with Link Lock Latches							
Part Number	Enclosure Overall Size HxWxD	Enclosure Inside AxBxC	Wt.	Carbon Steel Subpanel*	Fiberglass Subpanel*	Stainless Steel Subpanel*	Aluminum Subpanel*
HW-CC60604CHTL	7.41 x 7.79 x 4.31 (188.3 x 197.9 x 109.5)	6.77 x 6.77 x 4.06 (171.9 x 171.9 x 103.2)	2.5 lbs	HW-MP606CS	HW-MP606FG	HW-MP606SS	HW-MP606A
HW-CC80604CHTL	9.41 x 7.79 x 4.31 (239.1 x 197.9 x 109.5)	8.77 x 6.77 x 4.06 (222.7 x 171.9 x 103.2)	3.0 lbs	HW-MP806CS	HW-MP806FG	HW-MP806SS	HW-MP806A
HW-CC80804CHTL	9.39 x 9.76 x 4.31 (238.5 x 248.0 x 109.5)	8.74 x 8.74 x 4.06 (222.1 x 222.1 x 103.2)	3.5 lbs	HW-MP808CS	HW-MP808FG	HW-MP808SS	HW-MP808A
HW-CC100806CHTL	11.42 x 9.79 x 6.31 (290.1 x 248.6 x 160.3)	10.73 x 8.73 x 6.06 (272.5 x 221.7 x 153.9)	4.5 lbs	HW-MP1008CS	HW-MP1008FG	HW-MP1008SS	HW-MP1008A
HW-CC121006CHTL	13.45 x 11.83 x 6.31 (341.6 x 300.5 x 160.3)	12.69 x 10.69 x 6.06 (322.3 x 271.5 x 153.9)	6.0 lbs	HW-MP1210CS	HW-MP1210FG	HW-MP1210SS	HW-MP1210A
HW-CC141206CHTL	15.49 x 13.86 x 6.31 (393.4 x 352.0 x 160.3)	14.72 x 12.72 x 6.06 (373.9 x 323.1 x 153.9)	8.0 lbs	HW-MP1412CS	HW-MP1412FG	HW-MP1412SS	HW-MP1412A
HW-CC141208CHTL	15.49 x 13.86 x 8.34 (393.4 x 352.0 x 211.8)	14.66 x 12.66 x 8.06 (372.4 x 321.6 x 204.7)	9.5 lbs	HW-MP1412CS	HW-MP1412FG	HW-MP1412SS	HW-MP1412A
HW-CC161408CHTL	17.58 x 15.96 x 8.34 (446.6 x 405.4 x 211.8)	16.69 x 14.69 x 8.06 (424.0 x 373.1 x 204.7)	11.5 lbs	HW-MP1614CS	HW-MP1614FG	HW-MP1614SS	HW-MP1614A

Dimensions in inches (millimeters). (See dimensional drawings on page 6 of this section.)

*Note: Subpanels must be ordered separately. See pages 26-28 for more information.



Premier Series – Non-Metallic Enclosures

Dimensions for Premier Series Enclosures

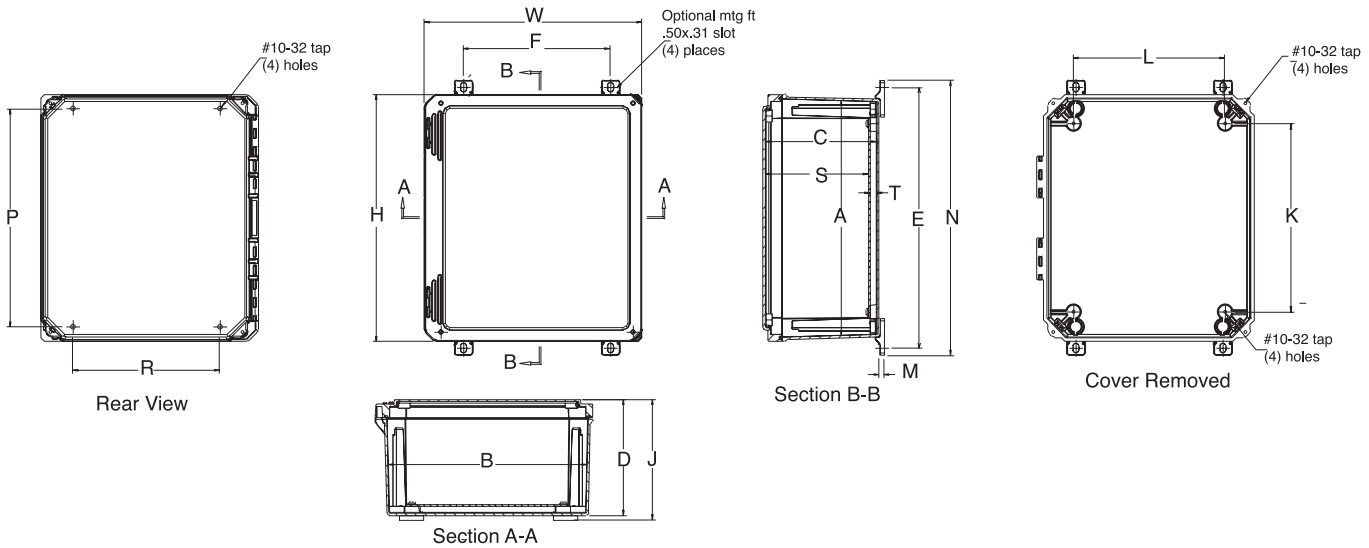

Dimensions for Premier Series Non-Metallic Enclosures											
Premier Base* Part Number	Enclosure Overall Size HxWxD	Enclosure Inside AxBxC	Mounting PxR	K	L	S	T	Optional Mounting Feet ExF	N	J	M
HW-*60604*	7.41 x 7.79 x 4.31 (188.3 x 197.9 x 109.5)	6.77 x 6.77 x 4.06 (171.9 x 171.9 x 103.2)	5.93 x 4.00 (150.6 x 101.6)	4.25 (108)	4.25 (108)	3.60 (91.5)	.38 (9.6)	8.24 x 4.00 (209.2 x 101.6)	9.02 (229.0)	4.56 (115.8)	.25 (6.35)
HW-*80604*	9.41 x 7.79 x 4.31 (239.1 x 197.9 x 109.5)	8.77 x 6.77 x 4.06 (222.7 x 171.9 x 103.2)	7.91 x 4.00 (200.9 x 101.6)	6.25 (159)	4.25 (108)	3.60 (91.5)	.38 (9.6)	10.21 x 4.00 (259.3 x 101.6)	10.98 (279.0)	4.56 (115.8)	.25 (6.35)
HW-*80804*	9.39 x 9.76 x 4.31 (238.5 x 248.0 x 109.5)	8.74 x 8.74 x 4.06 (222.1 x 222.1 x 103.2)	7.91 x 6.00 (200.9 x 152.4)	6.25 (159)	6.25 (159)	3.60 (91.5)	.38 (9.6)	10.21 x 6.00 (259.3 x 152.4)	10.98 (279.0)	4.56 (115.8)	.25 (6.35)
HW-*100806*	11.42 x 9.79 x 6.31 (290.1 x 248.6 x 160.3)	10.73 x 8.73 x 6.06 (272.5 x 221.7 x 153.9)	9.89 x 6.00 (251.2 x 152.4)	8.25 (210)	6.25 (159)	5.60 (142.3)	.38 (9.6)	12.19 x 6.00 (309.6 x 152.4)	12.96 (329.3)	6.56 (166.6)	.25 (6.35)
HW-*121006*	13.45 x 11.83 x 6.31 (341.6 x 300.5 x 160.3)	12.69 x 10.69 x 6.06 (322.3 x 271.5 x 153.9)	11.88 x 8.00 (301.7 x 203.2)	10.25 (260)	8.25 (210)	5.60 (142.3)	.38 (9.6)	14.18 x 8.00 (360.2 x 203.2)	14.95 (379.7)	6.56 (166.6)	.25 (6.35)
HW-*141206*	15.49 x 13.86 x 6.31 (393.4 x 352.0 x 160.3)	14.72 x 12.72 x 6.06 (373.9 x 323.1 x 153.9)	13.91 x 10.00 (353.3 x 254.0)	12.25 (311)	10.25 (260)	5.60 (142.3)	.38 (9.6)	16.21 x 10.00 (411.7 x 254.0)	16.98 (431.4)	6.59 (167.4)	.25 (6.35)
HW-*141208*	15.49 x 13.86 x 8.34 (393.4 x 352.0 x 211.8)	14.66 x 12.66 x 8.06 (372.4 x 321.6 x 204.7)	13.88 x 10.00 (352.5 x 254.0)	12.25 (311)	10.25 (260)	7.60 (193.2)	.38 (9.6)	16.19 x 10.00 (411.2 x 254.0)	16.96 (430.9)	8.59 (218.2)	.25 (6.35)
HW-*161408*	17.58 x 15.96 x 8.34 (446.6 x 405.4 x 211.8)	16.69 x 14.69 x 8.06 (424.0 x 373.1 x 204.7)	15.96 x 12.00 (405.4 x 304.8)	14.25 (362)	12.25 (311)	7.60 (193.2)	.38 (9.6)	18.26 x 12.00 (464.0 x 304.8)	19.04 (483.5)	8.59 (218.2)	.25 (6.35)
HW-*181610*	19.77 x 18.15 x 10.34 (502.2 x 461.0 x 262.6)	18.63 x 16.63 x 10.06 (473.2 x 422.4 x 255.5)	17.94 x 14.00 (455.6 x 355.6)	16.25 (413)	14.25 (362)	9.60 (243.9)	.38 (9.6)	20.24 x 14.00 (514.3 x 355.6)	21.02 (533.8)	10.59 (268.9)	.25 (6.35)
HW-*201610*	21.79 x 18.16 x 10.34 (553.5 x 461.2 x 262.6)	20.63 x 16.63 x 10.06 (524.0 x 422.4 x 255.5)	19.96 x 14.00 (506.9 x 355.6)	18.25 (463)	14.25 (362)	9.59 (243.7)	.38 (9.6)	22.26 x 14.00 (565.6 x 355.6)	23.04 (585.1)	10.59 (268.9)	.25 (6.35)

Note: Dimensions in inches (millimeters). Letters in table correspond to letters on dimensional drawings.

Note: Base Part Number denotes enclosure size only. Defining alphabetical characters are represented by an asterisk(for example: HW-*60604* denotes dimensions for HW-60604CHSC, HW-60604CHQR, HW-CC60604CHQR, or HW-CC60604CHTL. Do not use Base Part Numbers to order enclosures. Use only complete part numbers when ordering.

For Optional Mounting Foot Kit for Premier Series see page 29. (Ref: HW-MGFTKIT)



WIEGMANN®