

**safety**

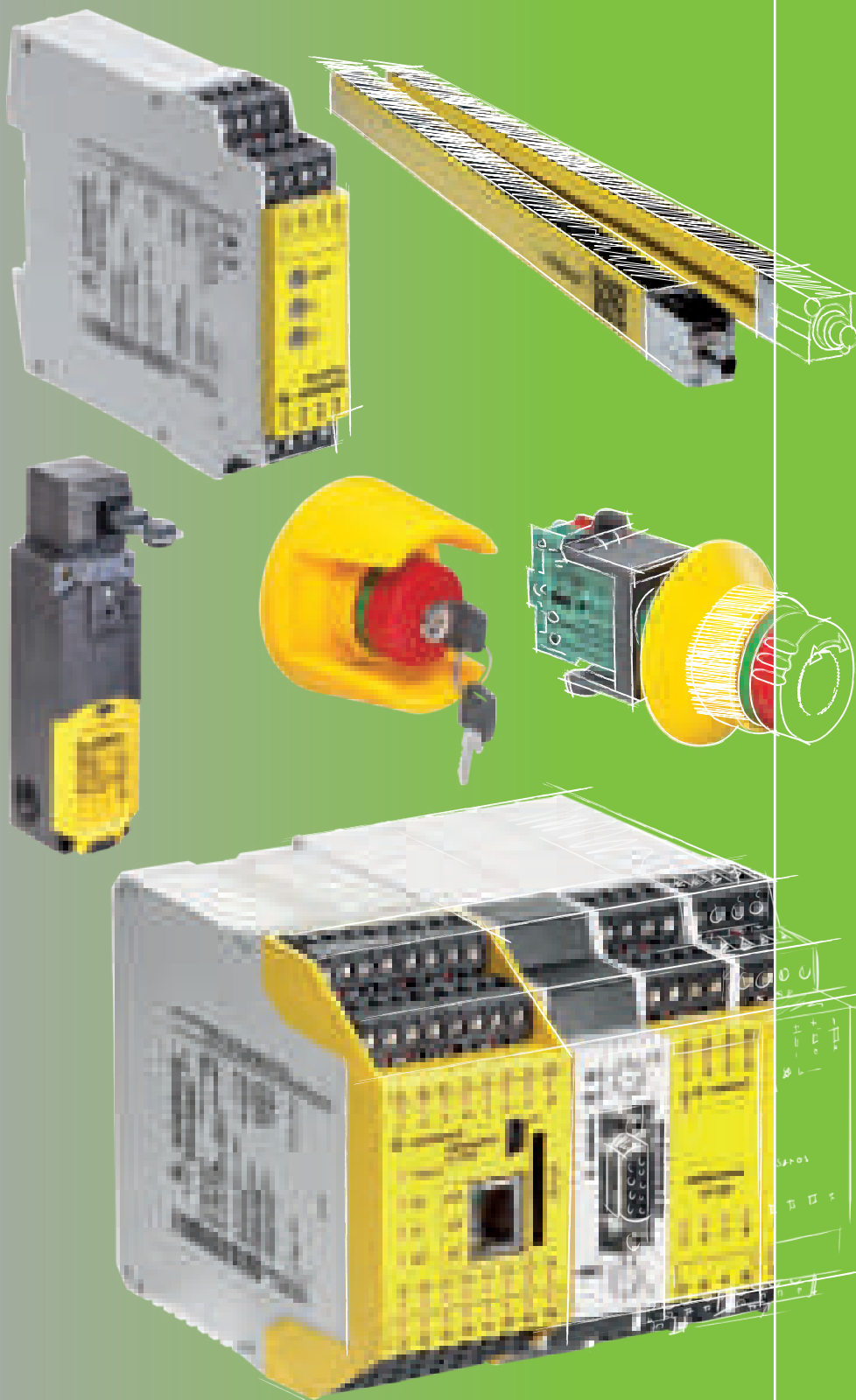

**wieland**



**safety**

Safe System Solutions  
for Automation Technology

Catalog 2016





▲ Sales Center  
in Bamberg



▲ Company headquarters  
in Bamberg



▲ STOCKO main plant  
in Wuppertal

# wieland group

## AT HOME ALL OVER THE WORLD

Wieland Electric GmbH is a medium-sized family-run electrical and electronics company headquartered in Bamberg. Founded in 1910, Wieland is one of the pioneers of electrical connection technology.

This family business with its international outlook is a market leader in pluggable installation technology for functional buildings, with subsidiaries worldwide and production lines not only in Bamberg but also in the Czech Republic and China.

The Wieland Group, which has included STOCKO Contact GmbH & Co. KG since 1998, is therefore represented in over 70 countries and employs some 2,200 people.



## *Solutions for*

*Building technology*

*Wind power*

*Machine building*

*Lighting  
technology*

*Heating, ventilation,  
air conditioning*



### Product portfolio

- Electronic and electrical engineering for the control cabinet
- Safety technology
- Network and field bus systems
- Energy bus systems for industry and buildings
- Connectors up to protection type IP6X
- Building automation
- PCB terminals and plug connectors
- Sensor/actuator cabling



### Industries

- Machine building
- Construction machines & cranes
- Buildings and lighting
- Logistics
- Power engineering
- Renewable energy sources
- Heating, ventilation and air conditioning systems



### Business services

- Pre-assembly and wiring
- Product labeling service
- Integrated solutions inside distributors
- Customized solutions
- On-site project support
- Optimization of decentralized, pluggable installation solutions
- Certified machine safety tests



### Safety training

- Software validation
- CSE certified safety engineers
- Basics and standards of functional safety
- Modification of old machines and major changes
- Design of safety functions and calculation with Sistema
- Machinery Directive, liability issues and CE conformity explanations



### Software/configuration tools

- **wiemarc**, labeling of terminal strips
- **wieplan**, configuration of terminal strips
- **revos** configurator for connectors
- **gesis**<sup>®</sup>PLAN for building installation
- **podis**<sup>®</sup>PLAN for configuring the **podis**<sup>®</sup> energy bus system
- **samos**<sup>®</sup>PLAN5+, programming tool for **samos**<sup>®</sup>PRO COMPACT



### Why Wieland?

- Standardized industrial solutions
- Customized solutions
- Support for your project
- Broad product portfolio
- Application worldwide due to international licenses
- Group-wide observance of human rights, including at suppliers
- Eco-friendly production

**RoHS**  
conform



Functional Safety  
Type Approved

# Overview of safety technology

From the **sensor**<sup>PRO</sup> safety sensors to the **safe**<sup>RELAY</sup> safety relay family and the modular **samos**<sup>®</sup> safety modules to the **samos**<sup>®</sup>PRO safety controllers, Wieland Electric offers the right product for your needs.



Safe signal acquisition  
**sensor**<sup>PRO</sup>

Universal safety relays  
**safe**<sup>RELAY</sup>

Modular safety modules  
**samos**<sup>®</sup>

Compact safety controllers  
**samos**<sup>®</sup> PRO COMPACT



## Tested technology

Of course, Wieland Electric offers only thoroughly tested and certified safety technology (i.e., all technical safety products have been approved by recognized testing institutes and meet current regulations and standards).

# Contents

<b>samos<sup>®</sup> PRO</b>	Preface		<b>samos<sup>®</sup> PRO COMPACT</b>	<b>8</b>	
			<b>samos<sup>®</sup> PLAN 5+</b>	<b>10</b>	
			SP-COP1 / SP-COP2	12	
			SP-SDIO / SP-SDI	14	
			Gateway	16	
			Accessories	17	
<b>samos<sup>®</sup></b>	Preface			<b>18</b>	
		SA-BM	Basic Module	<b>22</b>	
		SA-IN	Input Module	<b>23</b>	
		SA-OR-S1 / SA-OR-S2	Relais Output Module	<b>24</b>	
		Gateway	<b>25</b>		
<b>safe RELAY</b>	Preface			<b>26</b>	
	Overview			<b>28</b>	
	Basic Device	SNO 4083KM	Monitoring of emergency stop, safety gates and light barriers	<b>32</b>	
		SNO 4062K / KM	Monitoring of emergency stop, safety gates and light barriers	<b>34</b>	
		SNO 4063K / KM	Monitoring of emergency stop, safety gates and light barriers	<b>36</b>	
		SNA 4043K / KM / KE, SNA 4044K / KM	Monitoring of emergency stop, safety gates and light barriers	<b>38</b>	
		SNA 4063K / KM, SNA 4064 K / KM	Monitoring of emergency stop, safety gates and light barriers	<b>40</b>	
		SNO 4003K	Monitoring of emergency stop + safety gates	<b>42</b>	
		SNO 1012K	Monitoring of emergency stop + safety gates	<b>44</b>	
		SNS 4074K / SNS 4084K	Standstill monitor	<b>46</b>	
		SVM 4001K	Standstill monitor	<b>48</b>	
		SNT 4M63K	Monitoring of emergency stop + safety gates	<b>50</b>	
		SNZ 4052K	Two-hand relay type IIC	<b>52</b>	
		SNZ 1022K	Two-hand relay type IIA	<b>54</b>	
		Basic Device with time function	SNV 4063KL	Monitoring of emergency stop, safety gates and light barriers, OFF-delayed	<b>56</b>
			SNV 4063KP	Monitoring of emergency stop, safety gates and light barriers, ON-delayed	<b>58</b>
	SNV 4074SL / SNV 4076SL		Monitoring of emergency stop, safety gates and light barriers, OFF-delayed	<b>60</b>	
	SNV 4274 SL / SNV 4074ST		Monitoring of emergency stop, safety gates and light barriers, OFF-/ON-delayed	<b>62</b>	
	Safe Contact Expansion Relay	SNE 1	Contact Expansion	<b>64</b>	
		SNE 4003K	Contact Expansion	<b>66</b>	
		SNE 4004K / KV	Contact Expansion	<b>68</b>	
		SNE 4012K / SNE 4024K	Contact Expansion	<b>70</b>	
		SNE 4028S	Contact Expansion	<b>72</b>	
	<b>sensor PRO</b>	Preface			<b>74</b>
		Light curtains / light grids	SLC	Safety light curtain	<b>76</b>
			SLD	Safety light grid	<b>80</b>
				Accessories	<b>84</b>
Emergency stop		SNH	Emergency stop button	<b>90</b>	
Safety switch		SIN	Safety switch with guard locking	<b>96</b>	
		SMS	Safety switch with separate actuator	<b>100</b>	
Transponder switch		STS	Non-contact safety switches	<b>104</b>	
Magnetic switch		SMA	Magnetic safety switch	<b>108</b>	
Interface		SMI 1001	Magnetic switch interface	<b>112</b>	
<b>Complete solutions for machinery and plant engineering</b>		Graphic art	<b>114</b>		
<b>Support</b>		Software, Training, Hotline	<b>116</b>		
<b>Subsidiaries</b>		Addresses worldwide	<b>119</b>		
<b>Glossary</b>		Explanation on the overview	<b>120</b>		



**Machine building industry**  
**Process industry**  
**Elevator systems**  
**Combustion plants**

## Fit for *safety* with Wieland

Wieland supports and advises you – from the planning stage right through to start-up – throughout the entire life cycle of a machine or production system. The broad portfolio of safety switching devices covers all important safety functions and fulfills even complex customer requirements.

### Important standards for more safety

The safety products from Wieland Electric fulfil a number of international standards and regulations with machine and system safety for various applications playing a major role.

- EN/IEC 60204-1**
- EN/IEC 61508**
- EN/IEC 62061**
- EN ISO 13849-1**
- EN/IEC 61511**

### Solutions for many industries

The safety requirements for machine and system control are becoming more demanding in all areas. Wieland Electric offers tailored, innovative solutions ranging from sensors right down to safety control.



### Risk assessment according to EN ISO 13849-1

As the successor standard to EN 954-1, EN ISO 13849-1 is based on the known categories. EN ISO 13849-1 deals with the complete safety functions, including all the devices involved in their design. EN ISO 13849-1 makes a quantitative assessment of the safety functions. Using the categories as a basis, the so-called Performance Levels (PL) are applied for this purpose.

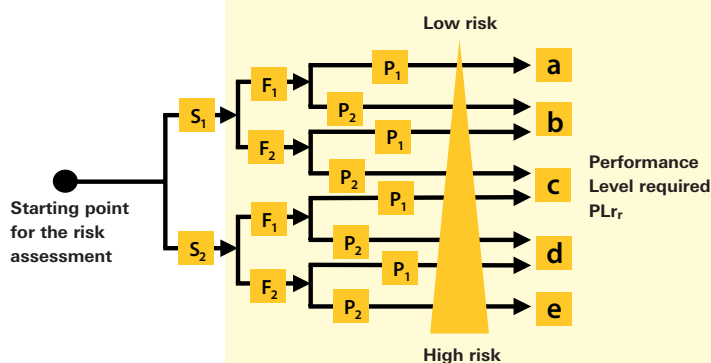

### Safety assessment according to EN/IEC 62061

In electrical control technology according to EN/IEC 62061, safety requirements can be divided into so-called Safety Integrity Levels (SIL). The risk assessment takes into account the severity of the injury (S), the frequency and duration of the exposure to the hazard (F), the probability of occurrence of a potentially hazardous incident (W), and the possibility of avoiding or limiting the damage (P). Hence, at the highest protection level SIL 3, the safety function must be maintained at all times.

Effects and severity	S	Class K = F + W + P				
		3-4	5-7	8-10	11-13	14-15
Death, loss of an eye or an arm	4	SIL 2	SIL 2	SIL 2	SIL 3	SIL 3
Permanent, loss of fingers	3		AM	SIL 1	SIL 2	SIL 3
Reversible, medical treatment	2			AM	SIL 1	SIL 2
Reversible, First Aid	1				AM	SIL 1





## **samos®** PRO COMPACT – The safety control of the next generation

With the highest power in the smallest space, the safety control **samos®** PRO COMPACT sets new standards in the area of machine automation.

### Overview of benefits

- 24 safe in- and outputs on 45 mm construction width for space and cost savings
- USB and Ethernet interfaces for remote maintenance always on board
- Industrial Ethernet protocols integrated
- 512 Mbyte program memory offers space for each project
- 4 A switching power at each output
- Ambient temperature  $-25\text{ }^{\circ}\text{C}$  to  $+65\text{ }^{\circ}\text{C}$
- Modular extendability to up to 172 secure in-/outputs
- Optical display of all in- and outputs in system
- Pluggable connection technology with either screw or push-in terminal blocks



# samos® PRO COMPACT — Universal application

samos® PRO COMPACT is suitable for monitoring non-contact safety sensors, Emergency Off buttons, protective door switches and door closures, two-hand controls as well as testable safety light barriers, light curtains and laser scanners.



## Applications in many branches

samos® PRO COMPACT is not only suitable for use in machinery and plant engineering but also, for example, for safety-related control tasks in elevator installations, industrial combustion plants and process technology systems.



# samos<sup>®</sup>PLAN 5+ – The programming tool for samos<sup>®</sup>PRO COMPACT

With the new software **samos<sup>®</sup>PLAN 5+** for the system **samos<sup>®</sup>PRO COMPACT**, programming is now even easier. With its many practical functions, **samos<sup>®</sup>PLAN 5+** supports the project developer in generating and validating safety applications, and documenting them in full compliance with the current Machinery Directive.

## Overview of benefits

- Comprehensive library of reliable, certified functions
- Configurable project documentation at the press of a button
- Integrated simulation and logic analysis of the safety functions
- Convenient support for fieldbus and industrial Ethernet integration
- Online diagnosis and remote maintenance for more transparency



## Function blocks

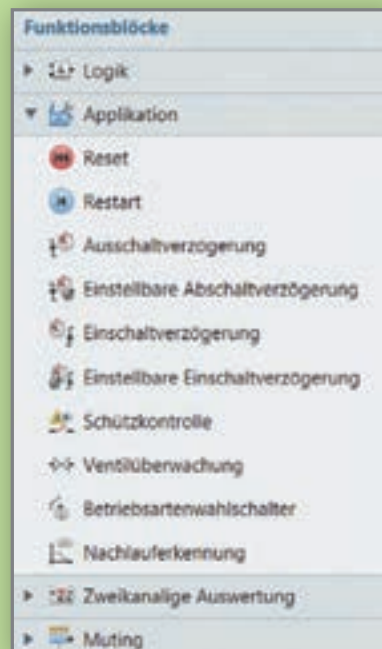

## Sensors



### Hardware



### Logic

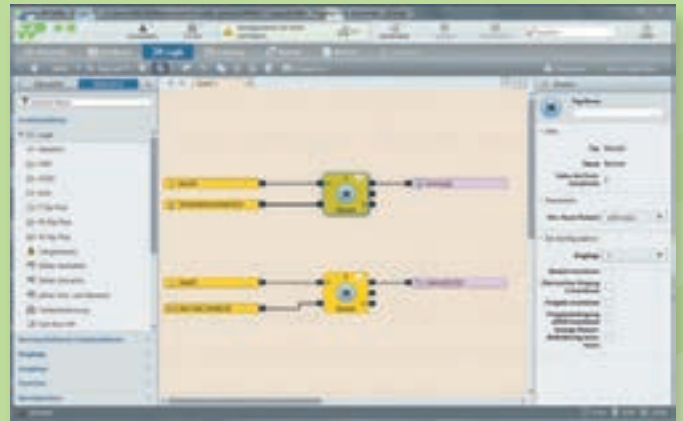

samos® PRO

### Simulation

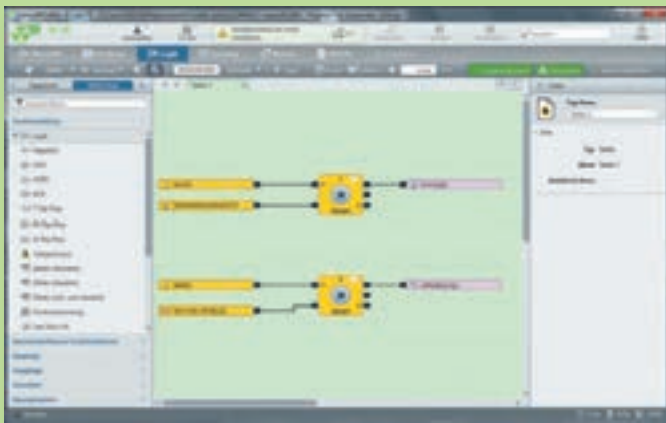

### Logic analysis

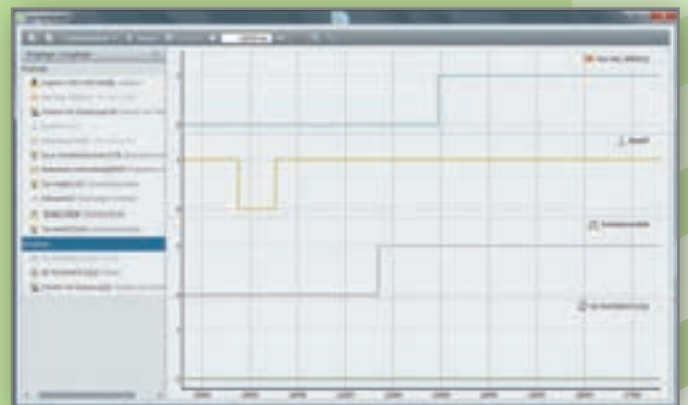

### Report

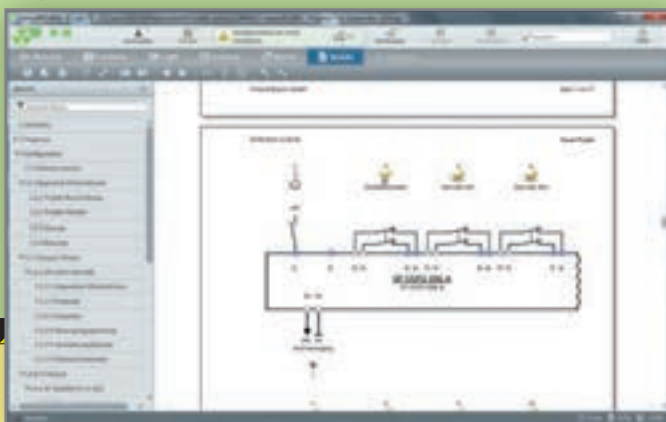

### Diagnosis



# SP-COP1 – COMPACT module



## Applications

- Machine building industry
- Combustion plants
- Elevator systems
- SIL<sub>CL</sub> 3 (EN 62061-1)
- PL e/Category 4 (EN ISO 13849-1)

## Features

- 20 safe inputs, 4 safe outputs
- USB interface
- SD slot for program memory (memory card SP-COP-CARD can be ordered separately)



## Overview of devices | part numbers

Type	Rated voltage	Terminals	Remarks	Part no.	Std. Pack
SP-COP1-A	24 V DC	Screw terminals, pluggable	USB-interface	R1.190.1110.0	1
SP-COP1-C	24 V DC	Push-in terminals, pluggable	USB-interface	R1.190.1120.0	1

## Technical data

<b>Function</b>		Safety control
Function display		24 LED green (in-/outputs) 3 LED green/red/yellow (module status)
<b>Supply circuit</b>		
Operating voltage range		16.8 V DC to 30 V DC
Rated power		3.5 W
Electrical isolation supply circuit - control circuit		No
<b>Secure input circuit I<sub>n</sub></b>		
Quantity/type		20 / digital
Primary voltage range		15 V DC to 30 V DC
Nominal current		2 mA
<b>Secure input circuit Q<sub>n</sub></b>		
Quantity/type		4 / digital
Nominal output voltage		24 V DC
Output current per output		4 A
Short-circuit protective device		Yes
<b>Interfaces</b>		
USB Mini interface		Yes
Ethernet interface		No
Industrial Ethernet protocol		No
Program memory		External
<b>General data</b>		
Protection class as per DIN EN 60529 (housing/terminals)		IP20
Air and creepage distances		EN 60664-1
Ambient temperature / storage temperature		-25 °C – +65 °C / -25 °C – +75 °C
Norms		EN 61508, EN 61511, EN 62061, EN ISO 13849-1, EN 50156-1, EN 81-1
Approvals		TÜV, cULus

# SP-COP2 – COMPACT module with ethernet



## Applications

- Machine building industry
- Combustion plants
- Elevator systems
- SIL<sub>CL</sub> 3 (EN 62061-1)
- PL e/Category 4 (EN ISO 13849-1)

## Features

- 16 inputs, 4 outputs, 4 configurable I/O
- USB interface
- Ethernet interface
- Industrial Ethernet protocol
- SD slot for program memory (memory card SP-COP-CARD can be ordered separately)

samos® PRO

## Overview of devices | part numbers

Type	Rated voltage	Terminals	Remarks	Part no.	Std. Pack
SP-COP2-EN-A	24 V DC	Screw terminals, pluggable	USB- / ETH-interface	R1.190.1210.0	1
SP-COP2-EN-C	24 V DC	Push-in terminals, pluggable	USB- / ETH-interface	R1.190.1220.0	1
SP-COP2-ENI-A	24 V DC	Screw terminals, pluggable	USB- / ETH-interface	R1.190.1310.0	1
SP-COP2-ENI-C	24 V DC	Push-in terminals, pluggable	USB- / ETH-interface	R1.190.1320.0	1

## Technical data

Function		Safety control	
Function display		24 LED green (in-/outputs)	
		4 LED green/red/yellow (module status)	
Supply circuit			
Operating voltage range		16.8 V DC to 30 V DC	
Rated power		3.5 W	
Electrical isolation supply circuit - control circuit		No	
Secure input circuit I <sub>n</sub>	SP-COP2-EN	SP-COP2-ENI	
Quantity/type	20 (16) / digital	20 (16) / digital	
Primary voltage range	15 V DC to 30 V DC	15 V DC to 30 V DC	
Nominal current	2 mA	2 mA	
Secure input circuit Q <sub>n</sub>			
Quantity/type	4 (8) / digital	4 (8) / digital	
Nominal output voltage	24 V DC	24 V DC	
Output current per output	4 A	4 A	
Short-circuit protective device	Yes	Yes	
Interfaces			
USB Mini interface	Yes	Yes	
Ethernet interface	Yes	Yes	
Industrial Ethernet protocol	No	Modbus TCP, Profinet, Ethernet IP	
Program memory	External	External	
General data			
Protection class as per DIN EN 60529 (housing/terminals)		IP20	
Air and creepage distances		EN 60664-1	
Ambient temperature / storage temperature		-25 °C – +65 °C / -25 °C – +75 °C	
Norms		EN 61508, EN 61511, EN 62061, EN ISO 13849-1, EN 50156-1, EN 81-1	
Approvals		TÜV, cULus	

# SP-SDIO – Input-/ output module



## Applications

- Machine building industry
- Combustion plants
- Elevator systems
- SIL<sub>CL</sub> 3 (EN 62061-1)
- PL e/Category 4 (EN ISO 13849-1)

## Features

- 8 safe inputs
- 4 safe outputs (with/without output test-pulses)
- 2 outputs (e.g., test signals)

## Overview of devices | part numbers

Type	Rated voltage	Terminals	Remarks	Part no.	Std. Pack
SP-SDIO84-P1-K-A	24 V DC	Screw terminals, pluggable	with/without output test-pulses	R1.190.0030.0	1
SP-SDIO84-P1-K-C	24 V DC	Push-in terminals, pluggable	with/without output test-pulses	R1.190.0040.0	1

## Technical data

Function display	13 LEDs, green/red
<b>Power supply circuit</b>	
Operating voltage range	16.8 V DC to 30 V DC
Rated consumption	1.8 W
Electrical isolation power supply circuit - control circuit	no
<b>Safe input circuit I1 – I8</b>	
Quantity / type	8 / digital
Input voltage range	15 V DC to 30 V DC
Rated current	3 mA
<b>Safe output circuits Q1 – Q4</b>	
Quantity / type	4 / digital
Output voltage	24 V DC
Output current I <sub>n</sub> per exit	4 A
<b>Output circuits X1, X2</b>	
Quantity / type	2 / digital
Output voltage	24 V DC
Output current I <sub>n</sub> per exit	0.5 A
<b>General data</b>	
Protection degree according to DIN 60529 (housing / terminals)	IP40 / IP20
Creepage distances and clearances	EN 60664-1
Ambient temperature / storage temperature	-25°C – +65°C / -25°C – +75°C
Standards	EN 61508, EN 61511, EN 62061, EN ISO 13849-1, EN 50156-1, EN 81-1
Approvals	TÜV, cULus

# SP-SDI – Input module



## Applications

- Machine building industry
- Combustion plants
- Elevator systems
- SIL<sub>CL</sub> 3 (EN 62061-1)
- PL e/Category 4 (EN ISO 13849-1)

## Features

- 8 safe inputs
- 8 outputs (e.g., test signals)



samos® PRO

## Overview of devices | part numbers

Type	Rated voltage	Terminals	Part no.	Std. pack
SP-SDI8-P1-K-A	24 V DC	Screw terminals, pluggable	R1.190.0050.0	1
SP-SDI8-P1-K-C	24 V DC	Push-in terminals, pluggable	R1.190.0060.0	1

## Technical data

Function display	13 LEDs, green/red
<b>Power supply circuit</b>	
Operating voltage range	16.8 V DC to 30 V DC
Rated consumption	1.8 W
Electrical isolation power supply circuit - control circuit	no
<b>Safe input circuit I1 – I8</b>	
Quantity / type	8 / digital
Input voltage range	15 V DC to 30 V DC
Rated current	3 mA
<b>Output circuits X1, X2</b>	
Quantity / type	2 / digital
Output voltage	24 V DC
Output current I <sub>n</sub> per exit	0.5 A
<b>General data</b>	
Protection degree according to DIN 60529 (housing / terminals)	IP40 / IP20
Creepage distances and clearances	EN 60664-1
Ambient temperature / storage temperature	-25°C – +65°C / -25°C – +75°C
Standards	EN 61508, EN 61511, EN 62061, EN ISO 13849-1, EN 50156-1, EN 81-1
Approvals	TÜV, cULus

### Note:

Safe relay contacts are expanded using the series SNE contact expansion relay (from Page 64). Types **SNE 4024K** and **SNE 4012K** in particular are ideal for contact expansion.

# Gateway

With the **samos®** PRO gateways, system information can be transferred between the **samos®** PRO safe control and an industrial control, a visualization system or a PC.



## Overview of devices | part numbers

Type	Rated voltage	Remark	Part no.	Std. pack
SP-CANopen	24 V DC	CANopen	R1.190.0210.0	1
SP-PROFIBUS-DP	24 V DC	PROFIBUS-DP	R1.190.0190.0	1
SP-EN-ETC	24 V DC	ETHERCAT	R1.190.0160.0	1

### Application examples:

- Direct HMI connection
- Remote diagnosis and programming
- Read and write 50 byte
- Input and output states
- Configuration data
- Process data from the PLC
- Fault data (e.g. fault data of the connected sensor technology)

### SP-CANopen

#### Features

- Fieldbus protocol CANopen
- Bidirectional communication with PLC
- Transfer rate up to 1 MBit/s
- Transfer of 50 bytes of data
- Simple configuration with **samos®** PLAN

### SP-PROFIBUS-DP

#### Features

- Fieldbus protocol PROFIBUS-DP
- Bidirectional communication with PLC
- Transfer rate 12 MBaud
- Transfer of 50 bytes of data
- Simple configuration with **samos®** PLAN

### SP-EN-ETC

#### Features

- EtherCAT industrial Ethernet protocol
- Bidirectional communication
- Transfer of 50 bytes of data
- Simple configuration with **samos®** PLAN

## Starter set & accessories



### samos<sup>®</sup>PRO COMPACT starter set

- A safe way to get started
- Contains all required components
- With programming tool **samos<sup>®</sup>PLAN 5+**
- With USB-RS232 converter

You can get the free programming tool **samos<sup>®</sup>PLAN 5+** at [www.wieland-electric.com](http://www.wieland-electric.com) Service / Software

samos<sup>®</sup> PRO



SP-COP-CARD1

SP-CABLE-ETH1

SP-CABLE-USB1

WKFN 2,5 E/35 GO-URL



SP-VISUAL-SET

SAFETY PUSH IN SET

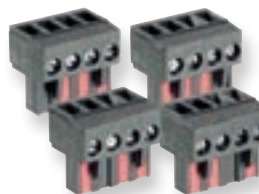

SAFETY SCHRAUBKL. SET

### samos<sup>®</sup>PRO accessories

- SP-COP-CARD1: Memory-card for SP-COP
- SP-CABLE-USB1: USB cable for SP-COP, 1.8 m
- SP-CABLE-ETH1: Ethernet cable for SP-COP, 2 m
- SP-COP-STARTER-SET: Set including SP-COP2-EN-A, SP-COP-CARD1, SP-PLAN5+, SP-CABLE-USB1, SP-CABLE-ETH1
- Programming software **samos<sup>®</sup>PLAN 5+**
- WKFN 2,5 E/35 GO-URL **fasis**-multi-tier block with diodes
- SP-FILTER1 output filter, 24 V DC, 680 nF
- SP-FILTER2 output filter, 24 V DC, 2,2 µF
- Screw terminal set with 4 different codings for 5 devices
- Push-in terminal set with 4 different codings for 5 devices

### Overview of devices | part numbers

Type	Description	Part no.	Std. pack
SP-COP-CARD1	Memory-card for SP-COP	R1.190.1000.0	1
SP-CABLE-USB1	USB cable for SP-COP, 1.8 m	R1.190.1010.0	1
SP-CABLE-ETH1	Ethernet cable for SP-COP, 2 m	R1.190.1020.0	1
SP-COP-STARTER-SET	Content: SP-COP2-EN-A, SP-COP-CARD1, SP-PLAN5+, SP-CABLE-USB1, SP-CABLE-ETH1	R1.190.1100.0	1
SP-VISUAL-SET	Visualization set (touch panel 3.5" color, SP-CABLE4, software driver)	R1.190.0280.0	1
SP-COVER	SD card slot cover for SP-COP modules	R1.190.1040.0	1
SAFETY SCHRAUBKL.SET	Screw terminal set with 4 different codings for 5 devices	99.208.9999.9	1
SAFETY PUSH IN SET	Push-in terminal set with 4 different codings for 5 devices	99.209.9999.9	1
WKFN 2,5 E/35 GO-URL	<b>fasis</b> - multi-tier block with diodes	56.703.8755.9	100
APFN 2,5 E/35	End plate	07.312.7355.0	10



## samos® – safety made simple











**samos®** stands for **SA**afety **MO**dular **S**ystem. The safety system with just a multifunctional, permanently coded basic modules is built on the modular kit principle and grows module by module along with the safety task.

- **samos®** combines a wide variety of safety sensors which monitor a machine or system for technical safety either individually, in combination or all together.
- **samos®** replaces special devices with pre-defined, practice-oriented function blocks for monitoring emergency stop, position switches, two-hand buttons and light curtains, for example.
- **samos®** uses safe logical link functions for simple creation of dependent or independent safety zones.
- **samos®** offers comprehensive diagnosis by gateways via Profibus-DP, CANopen and DeviceNet or via Industrial Ethernet.

All safety functions are set with a screwdriver without programming software and can be read at the device.



**Example: Single Functions**

-  Emergency stop
-  Safety door
-  Controlled stopping
-  Monitoring BWS type 4
-  Monitoring BWS type 2 with testing
-  Testable PDF sensors
-  Safe position monitoring
-  Static valve monitoring
-  Two-hand applications to IIIA and IIC
-  4-wire switching mats

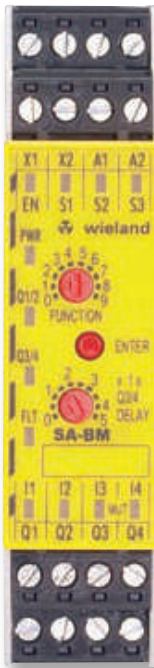

Set release delay of output Q4 or Q3 and Q4

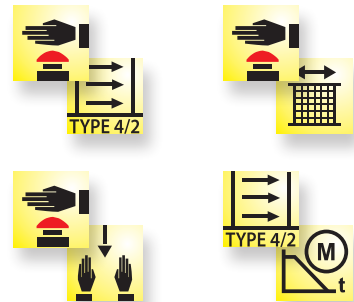

**Example: Combination Functions**



**Example: Dual Functions**



**Example: Special Functions**

-  MAX. 5 s Jog mode
-  SETUP Setup mode
-  MUTING MUTING and BYPASS



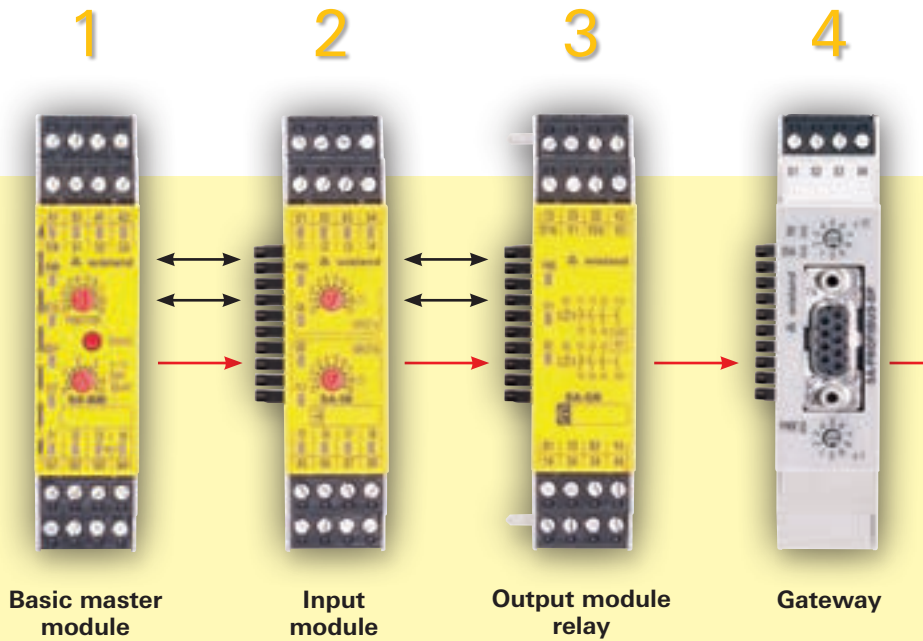

### Modular design

In its maximum configuration **samos®** consists of one basic master module and additional modules to expand function blocks, inputs and outputs.

- Up to **12** safe active modules (input modules)
- Up to **4** additional safe passive output module relays
- **1** additional gateway

- 1 Basic master module**  
Safety module with 9 function blocks, 8 safe inputs and 4 safe outputs (also suitable for stand-alone operation)
- 2 Input module**  
Expansion module with 10 function blocks and 8 safe inputs
- 3 Output module relay**  
Expansion modules with 2 or 4 safe, potential-free relay contacts
- 4 Gateway**  
Fieldbus or Ethernet gateways for easy diagnosis of the **samos®** system

## samos® – maximum flexibility

### Intelligently connected modules

The modules are connected to a standard DIN rail and pressed together. Connected on the left of the rail is the Master, the obligatory base module (with coding 1), input modules (coding matches the base module arranged to the left) and relay output modules. All modules in the **samos** overall system are permanently coded and are always permanently assigned to a similarly permanently coded basic module, which eliminates any confusion during service work, for instance.

The relay modules are integrated in the function via external wiring. If necessary such system group are made up of basic modules, input modules and relay output modules can be wired together. This allows the implementation of a wide variety of input/output functions with separate or combined effects.

### Functions with added value

The functions of the basic module and the input modules are set either individually or in combination on the front with 10-position rotary switches (e.g. emergency stop and protective door monitoring with controlled shutdown).

Clear handling – maximum flexibility

### samos® modules

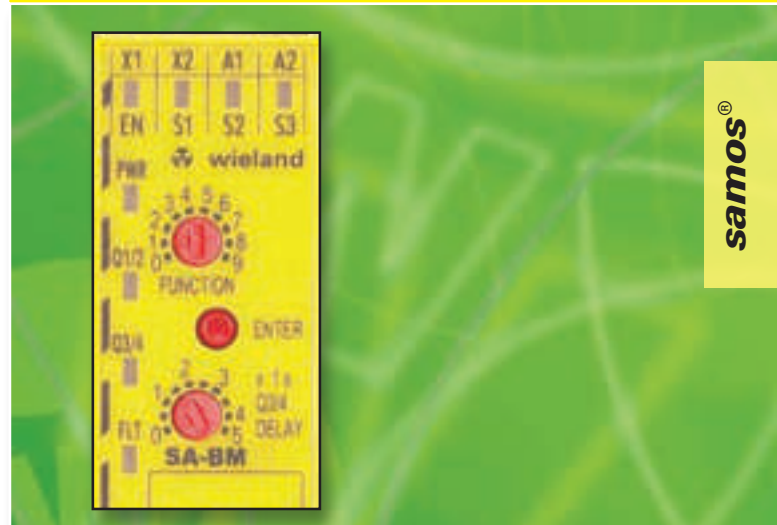

The clear and simple user interface helps to implement safe solutions.

Additional functions such as automatic reset, startup and re-startup blocking or retriggering of the off-delay are implemented with terminal configuration.



# SA-BM – Basic module



## Applications

- Machine building industry
- Combustion plants
- SIL<sub>CL</sub> 3 (EN 62061-1)
- PL e/Category 4 (EN ISO 13849-1)

## Features

- 9 function blocks
- 4 inputs for safety sensors
- 4 safe semiconductor inputs
- Adjustable OFF- delay



## Overview of devices | part numbers

Type	Rated voltage	Terminals	Coding	Part no.	Std. pack
SA-BM-S1-4EKL-A, 5s	24 V DC	Screw terminals, pluggable	1	R1.180.0010.0	1
SA-BM-S1-4EKL-A, 50s	24 V DC	Screw terminals, pluggable	1	R1.180.0020.0	1
SA-BM-S1-4EKL-C, 5s	24 V DC	Push-in terminals, pluggable	1	R1.180.0360.0	1
SA-BM-S1-4EKL-C, 50s	24 V DC	Push-in terminals, pluggable	1	R1.180.0370.0	1

## Technical data

Function display	12 LEDs, green/red
<b>Power supply circuit</b>	
Operating voltage range	19.2 V DC to 30 V DC
Rated consumption	1.8 W
Electrical isolation power supply circuit - control circuit	no
<b>Safe input circuit I1 – I4</b>	
Input voltage range	15 V DC to 30 V DC
Rated current	3 mA
<b>Safe control circuits EN, S1 – S3</b>	
Input voltage range	15 V DC to 30 V DC
Rated current	3 mA
<b>Safe output circuits Q1 – Q4</b>	
Output voltage	24 V DC
Output current I <sub>n</sub> per exit	2 A
<b>Output circuits X1, X2</b>	
Output voltage	24 V DC
Output current I <sub>n</sub> per exit	0.5 A
<b>General technical data</b>	
Protection degree according to DIN 60529 (housing / terminals)	IP40 / IP20
Creepage distances and clearances	EN 60664-1
Ambient temperature / storage temperature	-25°C – +55°C / -25°C – +75°C
Standards	EN 61508, EN 62061, EN ISO 13849-1, EN 50156-1
Approvals	TÜV, cULus

# SA-IN – Input module



## Applications

- Machine building industry
- Combustion plants
- SIL<sub>CL</sub> 3 (EN 62061-1)
- PL e/Category 4 (EN ISO 13849-1)

## Features

- 10 functional modules
- 2 x 4 inputs for sensors
- 2 x 4 test signal outputs

## Overview of devices | part numbers

Type	Rated voltage	Terminals	Coding	Part no.	Std. pack
SA-IN-S1-K-A	24 V DC	Screw terminals, pluggable	1	R1.180.0070.0	1
SA-IN-S1-K-C	24 V DC	Push-in terminals, pluggable	1	R1.180.0420.0	1

## Technical data

Function display	12 LEDs, green/red
<b>Power supply circuit</b>	
Operating voltage range	19.2 V DC to 30 V DC
Rated consumption	1.2 W
Electrical isolation power supply circuit - control circuit	no
<b>Safe input circuit I1 – I8</b>	
Input voltage range	15 V DC to 30 V DC
Rated current	3 mA
<b>Output circuits X1, X8</b>	
Output voltage	24 V DC
Output current I <sub>n</sub> per exit	0.5 A
<b>General technical data</b>	
Protection degree according to DIN 60529 (housing / terminals)	IP40 / IP20
Creepage distances and clearances	EN 60664-1
Ambient temperature / storage temperature	-25°C – +55°C / -25°C – +75°C
Standards	EN 61508, EN 62061, EN ISO 13849-1, EN 50156-1
Approvals	TÜV, cULus

# SA-OR – Output module



## Applications

- Machine building industry
- Combustion plants
- SIL<sub>CL</sub> 3 (EN 62061-1)
- PL e/Category 4 (EN ISO 13849-1)

## Features

- Output module **SA-OR-S1**
  - 2 x 2 safe enabling with switching up to 230 V AC / 6 A
  - 2 x outputs 24 V DC / 50 mA
  - 2 x 1 feedback circuit (NC contact)
- Output module **SA-OR-S2**
  - 1 x 2 safe enabling with switching up to 230 V AC / 6 A
  - 1 x 1 potential-carrying safe output 24 V DC / 50 mA for signaling or safe logical operation
  - 1 x 1 feedback circuit (NC contact)

## Overview of devices | part numbers

Type	Rated voltage	Terminals	Part no.	Std. pack
SA-OR-S1-4RK-A	24 V DC	Screw terminals, pluggable	R1.180.0080.0	1
SA-OR-S2-2RK-A	24 V DC	Screw terminals, pluggable	R1.180.0320.0	1
SA-OR-S1-4RK-C	24 V DC	Push-in terminals, pluggable	R1.180.0430.0	1
SA-OR-S2-2RK-C	24 V DC	Push-in terminals, pluggable	R1.180.0440.0	1

## Technical data

Function display	3 or 2 LEDs, green
<b>Input circuit B1, B2</b>	
Input voltage range	18 V DC to 30 V DC
Electrical isolation power supply circuit – input circuit	no
Electrical isolation input circuit - output circuit	yes
Electrical isolation power supply circuit - output circuit	yes
Rated consumption	2.2 W to 1.1 W
Release delay	30 ms
<b>Output circuits (relays)</b>	
Switching voltage	230 V AC
Output current I <sub>n</sub> per exit	6 A
<b>Output circuits (Y14, Y24)</b>	
Switching voltage	30 V DC
Output current I <sub>n</sub> per exit	75 mA
<b>General technical data</b>	
Protection degree according to DIN 60529 (housing / terminals)	IP40 / IP20
Creepage distances and clearances	EN 60664-1
Ambient temperature / storage temperature	-25°C – +55°C / -25°C – +75°C
Standards	EN 61508, EN 62061, EN ISO 13849-1, EN 50156-1
Approvals	TÜV, cULus

# Gateway

With the **samos®** gateways, system information can be transferred from the configurable **samos®** safety system to an industrial control or a visualization system, for example

### Application examples:

- Input and Output states
- Configuration data
- Fault data (e.g., configuration faults, faults during operation)



### SA-PROFIBUS-DP

#### Features

- Fieldbus protocol PROFIBUS-DP
- Communication with PLC
- Transfer rate up to 12 MBaud
- 4 semi-conductor outputs on board



### SA-DeviceNet

#### Features

- Fieldbus protocol DeviceNet
- Communication with PLC
- Transfer rate up to 500 KBit/s
- 4 semi-conductor outputs on board



### SA-CANopen

#### Features

- Fieldbus protocol CANopen
- Communication with PLC
- Transfer rate up to 1 MBit/s
- 4 semi-conductor outputs on board



## Overview of devices | part numbers

Type	Rated voltage	Terminals	Part no.	Std. pack
SA-CANopen-A	24 V DC	Screw terminals, pluggable	R1.180.0100.0	1
SA-DeviceNet-A	24 V DC	Screw terminals, pluggable	R1.180.0350.0	1
SA-PROFIBUS-DP-A	24 V DC	Screw terminals, pluggable	R1.180.0090.0	1



## **safe** RELAY – universal safety relays

The **safe** RELAY safety relays offer customized solutions for the safety of man and machine. These devices combine excellent technical performance with efficient use in everyday industrial applications. Compact design, flexible use and flexible connection methods are the decisive advantages of these devices. Depending on the application and the selected device, the safety relays can be used up to PL e/Category 4 (EN ISO 13849-1) or SIL 3 (EN 62061).

### Versatile application options

- Emergency stop monitoring
- Monitoring of protective doors and interlocks
- Light curtain monitoring
- Two-hand relay
- Monitoring of valves and limit value switches
- Safe contact expansions

Safety relays

**safe** RELAY

The simple and safe  
connection for every situation.



Basic devices

**SNA, SNO, SNS, SNT, SNZ**



**Basic devices**

The basic devices of the **SNA, SNO, SNS, SNT** and **SNZ** device families feature a safe internal logic component for the monitoring of the respective safety functions.

Basic devices with time function

**SNV**



**Basic devices with time function**

The basic devices of the **SNV** device families feature a safe internal logic component for the monitoring of the respective safety functions. In addition, these devices offer time-delayed, safe outputs and a corresponding time setting on the device.

Contact expansion relays

**SNE**



**Contact expansion relays**

The contact expansion relays of the **SNE** device family feature a redundant internal structure and are used for contact multiplication on, for example, basic devices.

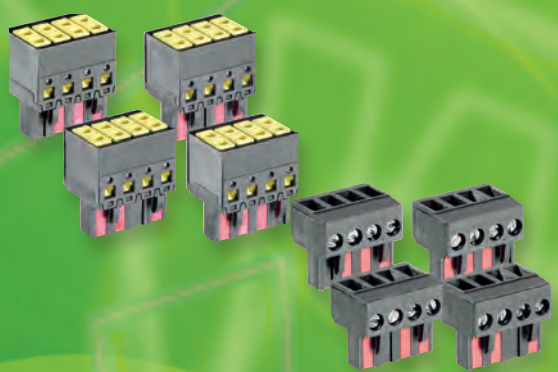

Further informations about the screw terminal set and the push-in terminal set see page 17.



# Overview – Basic Devices

Type	SNO 4083KM	SNO 4062K/KM	SNO 4063K/KM	SNA 4043K/KM	SNA 4044K/KM	SNA 4063K/KM	SNA 4064K/KM
Page	32	34	36	38	38	40	40
Application							
Input Circuits							
Start							
Contacts							
Characteristics							
Rated voltage DC (V)	24	24	12 24	24	24	24	24
Rated voltage AC (V)	115-230		24 115-120 230	24 42-48 115-120 230	24 42-48 115-120 230	24 42-48 115-120 230	24 42-48 115-120 230

<sup>1)</sup> PLe contact expansion

<sup>2)</sup> 24 V devices only

<sup>3)</sup> possible only in isolated cases and according to the risk assessment of the machine functions

	SNO 4003K	SNO 1012K	SNS 4074K/4084K	SVM 4001K	SNT 4M63K	SNZ 4052K	SNZ 1022K
	42	44	46	48	50	52	54
						CH1 tsync CH2 0,5	CH1 tsync CH2 0,5
	AUTO-RESET	AUTO-RESET	AUTO-RESET	AUTO-RESET	AUTO-RESET	AUTO-RESET	AUTO-RESET
	24	24	24	24	24	24	24
	24 115-120 230	24			24 115-120 230	24 115-120 230	24 115-230

# Overview – Basic Devices with time function

Type	SNV 4063KL	SNV 4063KP	SNV 4074SL	SNV 4076SL	SNV 4274SL	SNV 4074ST		
Page	56	58	60	60	62	62		
Application								
Input Circuits								
Start								
Contacts								
Characteristics								
Rated voltage DC (V)	24	24	24	24	24	24		
Rated voltage AC (V)			115-230	115-230	115-230	115-230		

<sup>1)</sup> applies to undelayed contacts; the following applies to delayed contacts: PL d / category 3 / SILCL 2

<sup>2)</sup> depends on the category of the basic device or the safety analysis

# Contact-Expansion Relais

	SNE 1	SNE 4003K	SNE 4004K	SNE 4004KV	SNE 4012K	SNE 4024K	SNE 4028S
	64	66	68	68	70	70	72
	24	24	24	24	24	24	24
			24				24 115-230



## Overview of devices | part numbers

Type	Rated voltage	Synchr. Time	Terminals	Part no.	Std. pack
SNO 4083KM-A	24 V DC	1.5 s	Screw terminals, pluggable	R1.188.3580.0	1
SNO 4083KM-A	115-230 V AC	1.5 s	Screw terminals, pluggable	R1.188.3590.0	1
SNO 4083KM-C	24 V DC	1.5 s	Push-in terminals, pluggable	R1.188.3600.0	1
SNO 4083KM-C	115-230 V AC	1.5 s	Push-in terminals, pluggable	R1.188.3610.0	1
SNO 4083KM-A	24 V DC	0.5 s	Screw terminals, pluggable	R1.188.3830.0	1
SNO 4083KM-A	115-230 V AC	0.5 s	Screw terminals, pluggable	R1.188.3840.0	1
SNO 4083KM-C	24 V DC	0.5 s	Push-in terminals, pluggable	R1.188.3850.0	1
SNO 4083KM-C	115-230 V AC	0.5 s	Push-in terminals, pluggable	R1.188.3860.0	1

## Technical data

<b>Function</b>	Emergency stop relay	
Function display	3 LEDs, green	
<b>Power supply circuit</b>		
Rated voltage $U_N$	A1, A2	24 V DC/ 115-230 V AC
Rated consumption	24 V DC	1.6 W
	115-230 V AC	1.8 W / 4.0 VA
Rated frequency	50 - 60 Hz	
Operating voltage range $U_B$	0.85 - 1.1 x $U_N$	
Electrical isolation supply circuit - control circuit	yes (at $U_N = 115-230$ V AC)	
<b>Control circuit</b>		
Rated output voltage	S11/S21	22.5 V DC
Input current / peak current	S12, S22	25 mA / 100 mA
	S14, S34	3 mA / 5 mA
Response time $t_{A1} / t_{A2}$	250 ms	
Minimum ON time $t_M$	60 ms	
Recovery time $t_W$	120 ms	
Release time $t_R$	20 ms	
Synchronous time $t_S$	0.5 s / 1.5 s	
Permissible test pulse time $t_{TP}$	< 0,8 ms	
Max. resistivity, per channel <sup>1)</sup>	24 V DC	$\leq (5 + (1.176 \times U_B / U_N - 1) \times 100) \Omega$
	115-230 V AC	$\leq 12 \Omega$
<b>Output circuit</b>		
Enabling paths	13/14, 23/24, 33/34	normally open contact
Signaling paths	41/42	normally closed contact
Contact assignment	forcefully guided	
Contact type	Ag-alloy, gold-plated	
Rated switching voltage	enabling / signaling path	230 V AC
Max. thermal current $I_{th}$	enabling / signaling path	6 A / 2 A
Max. total current $I^2$ of all current path	( $T_u = 55$ °C) / ( $T_u = 65$ °C)	25 A <sup>2</sup> / 9 A <sup>2</sup>
Application category (NO)	AC-15	$U_o$ 230V, $I_o$ 5 A
	DC-13	$U_o$ 24V, $I_o$ 5A
Short-circuit protection (NO), lead fuse / circuit breaker	6 A class gG / melting integral < 100 A <sup>2</sup> s	
Mechanical life	10 <sup>7</sup> switching cycles	
<b>General data</b>		
Creepage distances and clearances between the circuits	EN 60664-1	
Protection degree according to EN 60529 (housing / terminals)	IP40 / IP20	
Ambient temperature / storage temperature	-25 °C - +65 °C / -25 °C - + 75 °C	
Wire ranges screw terminals,	fine-stranded / solid	1 x 0.2 mm <sup>2</sup> – 2.5 mm <sup>2</sup> / 2 x 0.2 mm <sup>2</sup> – 1.0 mm <sup>2</sup>
	fine-stranded with ferrules	1 x 0.25 mm <sup>2</sup> – 2.5 mm <sup>2</sup> / 2 x 0.25 mm <sup>2</sup> – 1.0 mm <sup>2</sup>
Permissible torque	0.5 - 0.6 Nm	
Wire ranges push-in terminals	1 x 0,25 mm <sup>2</sup> – 1.5 mm <sup>2</sup>	
Weight	24 V AC/DC device / AC device	0.2 kg
Standards	EN ISO 13849-1, EN 62061, EN 81-1, EN 50156-1, EN 61511	
Approvals	TÜV, cULus, CCC, GL	

<sup>1)</sup> If two-channel devices are installed as single channel, the value is halved.

# SNO 4062K/KM

## Monitoring of emergency stop, safety gates and light barriers



### Function

#### SNO 4062K

The device is a two-channel switching device for emergency stop applications with self-monitoring on each ON-OFF cycle. It complies with EN 60204-1 and is equipped with forcibly guided relays.

#### Basic function:

With supply voltage applied to terminals A1/A2 and the safety inputs closed, pressing the reset button closes the enabling current paths (manual start). When the safety inputs are opened/de-energized the enabling current paths will open.

- **Manual start** When the safety inputs are closed, a button is used to open reset input S34 (triggering with falling edge) or to close reset input S35 (triggering with rising edge).
- **Automatic start** Reset input S35 is connected to S33. The device starts with the rising edge of the signal on safety input S12.

### Applications

- Protection of people and machinery
- Monitoring of emergency stop applications
- Monitoring of safety gates
- Monitoring of light barriers
- Up to PL e/Category 4 (EN ISO 13849-1)
- Up to SIL<sub>CL</sub> 3 (EN 62061)

### Features

- Stop Category 0 according to EN 60204-1
- Reset button monitoring
- Manual or automatic start
- Single-channel or two-channel control
- Cross monitoring
- 2 enabling current paths, 1 signal current path

#### SNO 4062KM

The function of this device corresponds to that of the SNO 4062K without synchrocheck. The device is suitable for connecting to light curtains for Type 4 (EN 61496-1) and connecting to short-circuit forming 4-wire safety mats, switching strips or switching edges (without monitoring resistance).

- **Safety mats** The device must be operated with two channels and cross monitoring. If there is resistance < 50 Ω / channel and a short circuit between the channels (S11/S12 and S21/S22) the enabling paths open and the SUPPLY LEDs flashes.
- **Light curtain for Type 4 (EN 61496-1)** The device will be operated with two channels and without cross monitoring, if the light curtain connected to the OSSD detects a shunt fault on its own.

For applications with tactile operating modes (rapid ON-OFF cycles, for example with manual supply) we recommend using SNO 4062KM.

### Circuit diagram

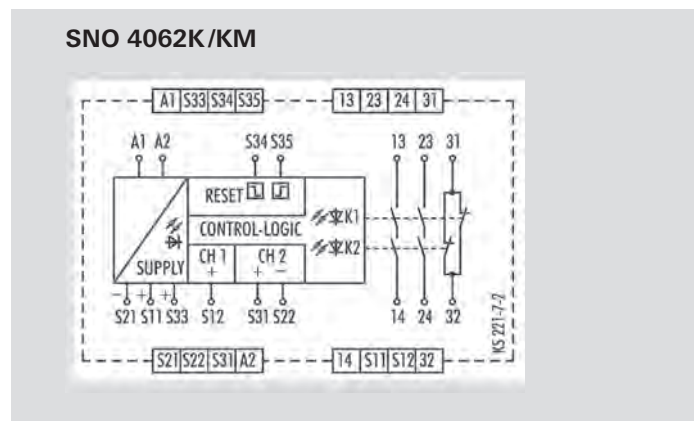

## Overview of devices | part numbers

Type	Rated voltage	Terminals	Part no.	Std. pack
SNO 4062K-A	24 V AC/DC	Screw terminals, pluggable	R1.188.0700.2	1
SNO 4062KM-A	24 V AC/DC	Screw terminals, pluggable	R1.188.0720.2	1
SNO 4062K-C	24 V AC/DC	Push-in terminals, pluggable	R1.188.2000.0	1

## Technical data

<b>Function</b>	Emergency stop relay	
Function display	3 LEDs, green	
<b>Power supply circuit</b>		
Rated voltage $U_N$	A1, A2	24 V AC/DC
Rated consumption	24 V DC (K / KM)	2.0 W / 2.1 W
Rated frequency	50 - 60 Hz	
Operating voltage range $U_B$	0,85 - 1,1 x $U_N$	
Electrical isolation supply circuit - control circuit	no	
<b>Control circuit</b>		
Rated output voltage	S11, S33/S21	22 V DC
Input current / peak current	S12, S31/S22	40 mA / 100 mA
	S34, S35	5 mA / 50 mA
Response time $t_{A1} / t_{A2}$	40 ms / 500 ms (KM: 40 ms / 80 ms)	
Minimum ON time $t_M$	50 ms	
Recovery time $t_W$	150 ms	
Release time $t_R$	15 ms	
Synchronous time $t_S$	200 ms (CH1 → CH2)	
Permissible test pulse time $t_{TP}$	< 1ms	
Max. resistivity, per channel <sup>1)</sup>	$\leq (5 + (1.176 \times U_B / U_N - 1) \times 100) \Omega$	
<b>Output circuit</b>		
Enabling paths	13/14, 23/24	normally open contact
Signaling paths	31/32	normally closed contact
Contact assignment	forceably guided	
Contact type	Ag-alloy, gold-plated	
Rated switching voltage	enabling / signaling path	230 V AC
Max. thermal current $I_{th}$	enabling / signaling path	6 A / 3 A
Max. total current $I^2$ of all current path	( $T_u = 55 \text{ °C}$ )	9 A <sup>2</sup>
Application category (NO)	AC-15	$U_o$ 230 V, $I_o$ 3 A
	DC-13	$U_o$ 24 V, $I_o$ 2.5A
Short-circuit protection (NO), lead fuse / circuit breaker	6 A class gG / melting integral < 100 A <sup>2</sup> s	
Mechanical life	10 <sup>7</sup> switching cycles	
<b>General data</b>		
Creepage distances and clearances between the circuits	EN 60664-1	
Protection degree according to EN 60529 (housing / terminals)	IP40 / IP20	
Ambient temperature / storage temperature	-25 °C - +55 °C / -25 °C - + 75 °C	
Wire ranges screw terminals,	fine-stranded / solid	1 x 0.2 mm <sup>2</sup> – 2.5 mm <sup>2</sup> / 2 x 0.2 mm <sup>2</sup> – 1.0 mm <sup>2</sup>
	fine-stranded with ferrules	1 x 0.25 mm <sup>2</sup> – 2.5 mm <sup>2</sup> / 2 x 0.25 mm <sup>2</sup> – 1.0 mm <sup>2</sup>
Permissible torque	0.5 - 0.6 Nm	
Wire ranges push-in terminals	1 x 0.25 mm <sup>2</sup> – 1.5 mm <sup>2</sup>	
Weight	24 V AC/DC device / AC device	0.21 kg
Standards	EN ISO 13849-1, EN 62061	
Approvals	DGUV, cULus, CCC	

<sup>1)</sup> If two-channel devices are installed as single channel, the value is halved.

# SNO 4063K/KM

## Monitoring of emergency stop, safety gates and light barriers



### Applications

- Protection of people and machinery
- Monitoring of emergency stop applications
- Monitoring of safety gates
- Monitoring of light barriers
- Up to PL e/Category 4 (EN ISO 13849-1)
- Up to SIL<sub>CL</sub> 3 (EN 62061)

### Features

- Stop Category 0 according to EN 60204-1
- Manual or automatic start
- Cross monitoring
- Single-channel or two-channel control
- 3 enabling current paths

### Function

#### SNO 4063K

The device is a two-channel switching device for emergency stop applications with self-monitoring on each ON-OFF cycle. It complies with EN 60204-1 and is equipped with forcibly guided relays.

After supply voltage has been applied to the A1/A2 terminals and the safety inputs have been closed, pressing the reset button closes the enabling current paths (manual start). When the safety inputs are opened/de-energized the enabling current paths will open.

- **Manual start** When the safety inputs are closed, a button is used to open reset input S34 (triggering with falling edge) or to close reset input S35 (triggering with rising edge).
- **Automatic start** Reset input S35 is connected to S33. The device starts with the rising edge of the signal on safety input S12.

#### SNO 4063KM

The function of this device corresponds to that of the SNO 4063K. The device is suitable for connecting to light curtains for Type 4 (EN 61496-1) and to short-circuit forming 4-wire safety mats, switching strips or switching edges (without monitoring resistance).

- **Safety mats** The device must be operated with two channels and cross monitoring. If there is resistance < 50 Ω / channel and a short circuit between the channels (S11/S12 and S21/S22) the enabling paths open and the SUPPLY LEDs flash.
- **Light curtain for Type 4 (EN 61496-1)** The device will be operated with two channels and without cross monitoring, if the light curtain connected to the OSSD detects a shunt fault on its own.

For applications with tactile operating modes (rapid ON-OFF cycles, for example at manual supply) we recommend the use of SNO 4063KM.

### Circuit diagram

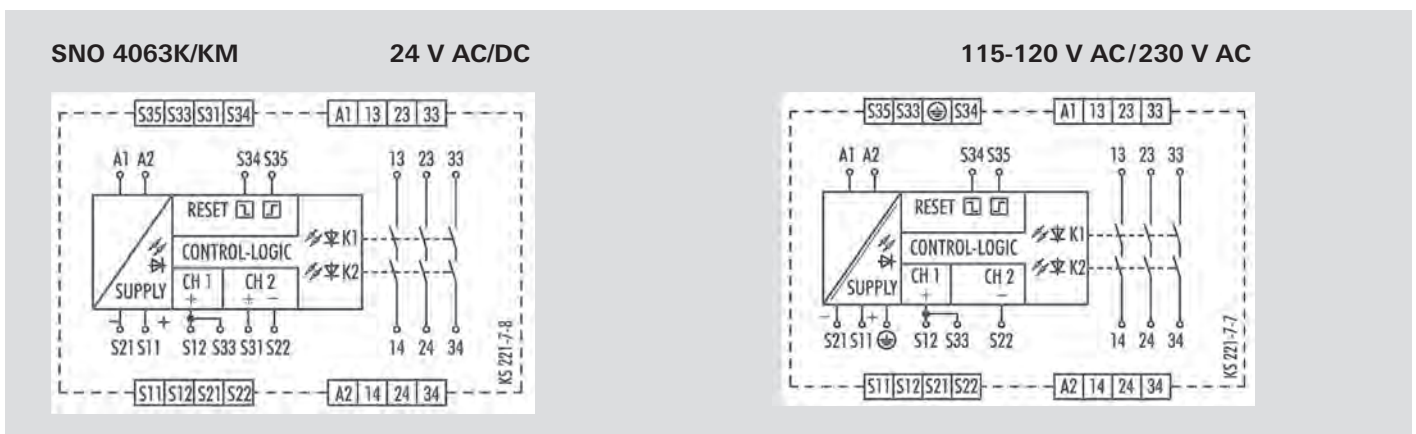

## Overview of devices | part numbers

Type	Rated voltage	Terminals	Part no.	Std. pack
SNO 4063K-A	12 V DC	Screw terminals, pluggable	R1.188.1120.0	1
	24 V AC/DC	Screw terminals, pluggable	R1.188.0990.0	1
	115 – 120 V AC	Screw terminals, pluggable	R1.188.1000.0	1
	230 V AC	Screw terminals, pluggable	R1.188.1010.0	1
SNO 4063K-C	24 V AC/DC	Push-in terminals, pluggable	R1.188.2450.0	1
SNO 4063KM-A	24 V AC/DC	Screw terminals, pluggable	R1.188.1280.0	1

## Technical data

<b>Function</b>		Emergency stop relay
Function display		3 LEDs, green
<b>Power supply circuit</b>		
Rated voltage $U_N$	A1, A2	24 V AC/DC, 115-120 V AC, 230 V AC
Rated consumption	24 V DC (K / KM)	2.0 W / 2.1 W
	115-120 V AC, 230 V AC	2.4 W / 4.4 VA
Rated frequency		50 - 60 Hz
Operating voltage range $U_B$		$0.85 - 1.1 \times U_N$
Electrical isolation supply circuit - control circuit		yes (at $U_N = 115-230$ V AC, 230 V AC)
<b>Control circuit</b>		
Rated output voltage	S11/S21	22 V DC
Input current / peak current	S12/S33, S31/S22	40 mA / 100 mA
	S34, S35	5 mA / 50 mA
Response time $t_{A1} / t_{A2}$		40 ms / 600 ms
Minimum ON time $t_M$		50 ms
Recovery time $t_W$		100 ms
Release time $t_R$		15 ms
Synchronous time $t_S$		200 ms (CH1 → CH2)
Permissible test pulse time $t_{TP}$		< 1 ms
Max. resistivity, per channel <sup>1)</sup>	24 V AC/DC	$\leq (5 + (1.176 \times U_B / U_N - 1) \times 100) \Omega$
	115-120 V AC, 230 V AC	$\leq (5 + (1.176 \times U_B / U_N - 1) \times 100) \Omega$
<b>Output circuit</b>		
Enabling paths	13/14, 23/24, 33/34	normally open contact
Contact assignment		forceably guided
Contact type		Ag-alloy, gold-plated
Rated switching voltage	enabling path	230 V AC
Max. thermal current $I_{th}$	enabling path	6 A
Max. total current $I^2$ of all current path	( $T_u = 55$ °C)	9 A <sup>2</sup>
Application category (NO)	AC-15	$U_e$ 230 V, $I_e$ 3 A
	DC-13	$U_e$ 24 V, $I_e$ 2.5 A
Short-circuit protection (NO), lead fuse / circuit breaker		6 A class gG / melting integral < 100 A <sup>2</sup> s
Mechanical life		10 <sup>7</sup> switching cycles
<b>General data</b>		
Creepage distances and clearances between the circuits		EN 60664-1
Protection degree according to EN 60529 (housing / terminals)		IP40 / IP20
Ambient temperature / storage temperature		-25 °C - +55 °C / -25 °C - + 75 °C
Wire ranges screw terminals,	fine-stranded / solid	1 x 0.2 mm <sup>2</sup> – 2.5 mm <sup>2</sup> / 2 x 0.2 mm <sup>2</sup> – 1.0 mm <sup>2</sup>
	fine-stranded with ferrules	1 x 0.25 mm <sup>2</sup> – 2.5 mm <sup>2</sup> / 2 x 0.25 mm <sup>2</sup> – 1.0 mm <sup>2</sup>
Permissible torque		0.5 - 0.6 Nm
Wire ranges push-in terminals		1 x 0.25 mm <sup>2</sup> – 1.5 mm <sup>2</sup>
Weight	24 V AC/DC device / AC device	0-21 kg / 0-25 kg
Standards		EN ISO 13849-1, EN 62061
Approvals		DGUV, cULus, CCC

<sup>1)</sup> If two-channel devices are installed as single channel, the value is halved.

# SNA 4043K/KM/KE, SNA 4044K/KM

## Monitoring of emergency stop, safety gates and light barriers



### Applications

- Protection of people and machinery
- Monitoring of emergency stop applications
- Monitoring of safety gates
- Monitoring of light barriers
- Up to PL e/Category 4 (EN ISO 13849-1)
- Up to SIL<sub>CL</sub> 3 (EN 62061)

### Features

- Stop Category 0 according to EN 60204-1
- Single-channel or two-channel control
- Automatic start
- Manual reset without monitoring
- Cross monitoring
- 3 to 4 enabling current paths

### Function

Emergency stop and safety gate monitor The safety switching devices of our SNA product line are used to monitor safety sensors (emergency stop buttons, safety gate switches, etc.), feature a large number of safety switching contacts (3 NO contacts/1 NC contact or 4 NO contacts) with a total width of only 22.5 mm at a constant current of up to 8 A. They can be implemented in the extended temperature range up to 65° C.

- **Automatic start** – Reset input S34 is connected to safety input S11. To monitor external contact blocks (EDM), their NC contacts must be connected in series between S34 and S11.
- **Manual start without monitoring** – Reset input S34 is connected to safety input S11 via a RESET button. To monitor external contact blocks (EDM), their NC contacts must be connected to the RESET button in series.
- **Monitoring of light curtains** – The KM device types are especially suitable for the monitoring of very fast tactile switching operations, for example in safety light curtain applications. Very short switch-off procedures of a few milliseconds are detected reliably and lead to the switching off of the internal relays.

### Circuit diagram

SNA 4043K/KM

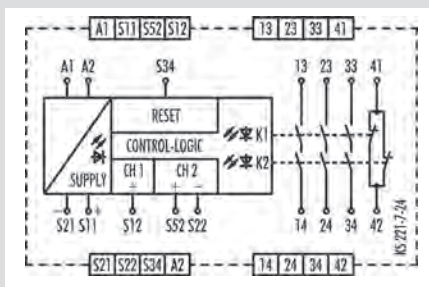

SNA 4043KE

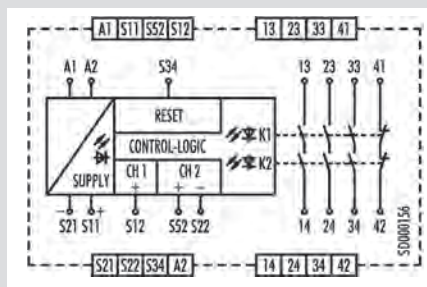

SNA 4044K/KM

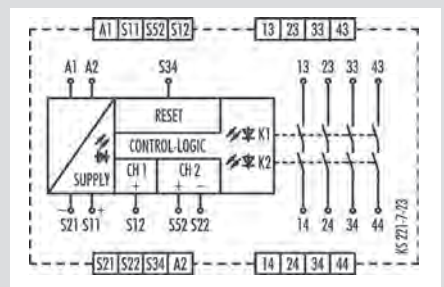

## Overview of devices | part numbers

Type	Rated voltage	Terminals	Part no.	Std. pack
SNA 4043K-A	24 V AC/DC	Screw terminals, pluggable	R1.188.1810.0	1
SNA 4043K-A	42-48 V AC	Screw terminals, pluggable	R1.188.1820.0	1
SNA 4043K-A	115-120 V AC	Screw terminals, pluggable	R1.188.1830.0	1
SNA 4043K-A	230 V AC	Screw terminals, pluggable	R1.188.1840.0	1
SNA 4043K-C	24 V AC/DC	Push-in terminals, pluggable	R1.188.1940.0	1
SNA 4043KM-A	24 V AC/DC	Screw terminals, pluggable	R1.188.3250.0	1
SNA 4043KM-C	24 V AC/DC	Push-in terminals, pluggable	R1.188.3400.0	1
SNA 4043KE-A	AC/DC 24 V	Screw terminals, pluggable	R1.188.3810.0	1
SNA 4043KE-C	AC/DC 24 V	Push-in terminals, pluggable	R1.188.3820.0	1
SNA 4044K-A	24 V AC/DC	Screw terminals, pluggable	R1.188.1860.0	1
SNA 4044K-A	42-48 V AC	Screw terminals, pluggable	R1.188.1870.0	1
SNA 4044K-A	115-120 V AC	Screw terminals, pluggable	R1.188.1880.0	1
SNA 4044K-A	230 V AC	Screw terminals, pluggable	R1.188.1890.0	1
SNA 4044K-C	24 V AC/DC	Push-in terminals, pluggable	R1.188.1960.0	1
SNA 4044KM-A	24 V AC/DC	Screw terminals, pluggable	R1.188.1480.0	1
SNA 4044KM-C	24 V AC/DC	Push-in terminals, pluggable	R1.188.3410.0	1

## Technical data

<b>Function</b>			Emergency stop relay
Function display			3 LEDs, green
<b>Power supply circuit</b>			
Rated voltage $U_N$	A1, A2	24 V AC/DC / 42-48 V AC / 115-120 V AC / 230 V AC	
Rated consumption	24 V DC / 24 V AC	1.6 W / 2.9 VA	
	42-48 V AC / 115-120 V AC / 230 V AC	2.3 W / 2.6 VA	
Rated frequency			50 - 60 Hz
Operating voltage range $U_B$			0.85 - 1.1 x $U_N$
Electrical isolation supply circuit - control circuit			yes (at $U_N = 42-48$ V AC, 115-230 V AC, 230 V AC)
<b>Control circuit</b>			
Rated output voltage	S11/S21	24 V DC	
Input current / peak current	S12, S52/S22   S34	25 mA / 100 mA   5 mA / 50 mA	
Response time $t_{A1}$ / $t_{A2}$			350 ms / 350 ms
Minimum ON time $t_M$			100 ms
Recovery time $t_W$			750 ms
Release time $t_R$			10 ms
Synchronous time $t_S$			no
Permissible test pulse time $t_{TP}$			< 1 ms
Max. resistivity, per channel <sup>1)</sup>	24V AC/DC	$\leq (5 + (1.176 \times U_B / U_N - 1) \times 100) \Omega$	
	42-48V AC / 115-120 V AC, 230 V AC	$\leq (5 + (1.176 \times U_B / U_N - 1) \times 100) \Omega$	
<b>Output circuit</b>	SNA 4043K/KM	SNA 4044K/KM	
Enabling paths	13/14, 23/24, 33/34	13/14, 23/24, 33/34, 43/44	normally open contact
Signaling paths	41/42	---	normally closed contact
Contact assignment			forceably guided
Contact type			Ag-alloy, gold-plated
Rated switching voltage	enabling / signaling path		230 V AC
Max. thermal current $I_{th}$	enabling / signaling path		8 A / 5 A
Max. total current $I^2$ of all current path	(Tu = 55 °C) / (Tu = 65 °C)		25 A <sup>2</sup> / 9 A <sup>2</sup>
Application category (NO)	AC-15   DC-13		$U_o$ 230 V, $I_o$ 3 A   $U_o$ 24 V, $I_o$ 3 A
Short-circuit protection (NO), lead fuse / circuit breaker			6 A class gG / melting integral < 100 A <sup>2</sup> s
Mechanical life			10 <sup>7</sup> switching cycles
<b>General data</b>			
Creepage distances and clearances between the circuits			EN 60664-1
Protection degree according to EN 60529 (housing / terminals)			IP40 / IP20
Ambient temperature / storage temperature			-25 °C - +65 °C / -25 °C - +75 °C
Wire ranges screw terminals,	fine-stranded / solid	1 x 0.2 mm <sup>2</sup> - 2.5 mm <sup>2</sup> / 2 x 0.2 mm <sup>2</sup> - 1.0 mm <sup>2</sup>	
	fine-stranded with ferrules	1 x 0.25 mm <sup>2</sup> - 2.5 mm <sup>2</sup> / 2 x 0.25 mm <sup>2</sup> - 1.0 mm <sup>2</sup>	
Permissible torque			0.5 - 0.6 Nm
Wire ranges push-in terminals			1 x 0.25 mm <sup>2</sup> - 1.5 mm <sup>2</sup>
Weight	24 V AC/DC device / AC device		0.21 kg / 0.25 kg
Standards			EN ISO 13849-1, EN 62061, EN 81-1, EN 50156-1, EN 61511
Approvals			TÜV, cULus, CCC, GL

<sup>1)</sup> If two-channel devices are installed as single channel, the value is halved.

# SNA 4063K/KM, SNA 4064K/KM

## Monitoring of emergency stop, safety gates and light barriers



### Applications

- Monitoring of emergency stop applications
- Monitoring of safety gates
- Monitoring of light barriers
- Up to PL e/Category 4 (EN ISO 13849-1)
- Up to SIL<sub>CL</sub> 3 (EN 62061)

### Features

- Stop Category 0 according to EN 60204-1
- Single-channel or two-channel control
- Manual reset with monitoring
- Cross monitoring
- 3 to 4 enabling current paths

### Function

After the supply voltage is applied to terminals A1/A2 and the safety inputs are closed, the enabling current paths (NO contacts) are closed and the signal current path (NC contact) is opened by pressing the reset button (manual start with monitoring). When the safety inputs are opened/de-energized, the enabling current paths (NO contacts) are opened immediately.

- **Manual start with monitoring** – Reset input S34 is connected to safety input S11 via a RESET button. To monitor external contact blocks (EDM), their NC contacts must be connected in series to the RESET button.
- **Monitoring of light curtains** – The **KM device types** are especially suitable for the monitoring of very fast tactile switching operations, for example in safety light curtain applications. Very short switch-off procedures of a few milliseconds are detected reliably and lead to the switching off of the internal relays.

### Circuit diagram

SNA 4063K/KM

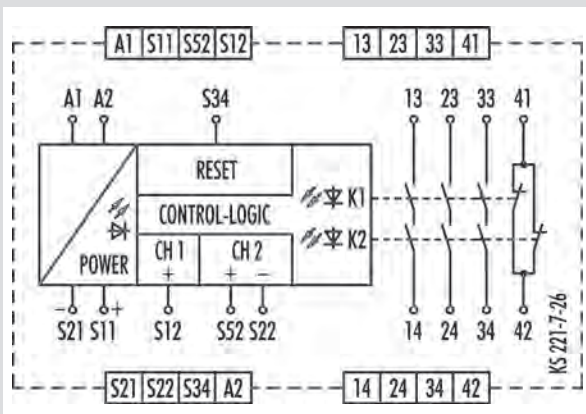

SNA 4064K/KM

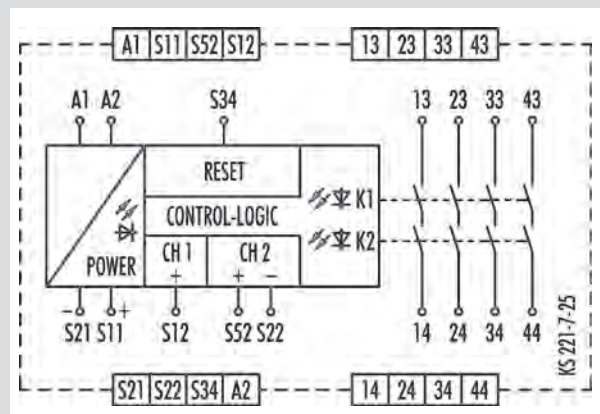

## Overview of devices | part numbers

Type	Rated voltage	Terminals	Part no.	Std. pack
SNA 4063K-A	24 V AC/DC	Screw terminals, pluggable	R1.188.1440.0	1
SNA 4063K-A	42-48 V AC	Screw terminals, pluggable	R1.188.1850.0	1
SNA 4063K-A	115-120 V AC	Screw terminals, pluggable	R1.188.1450.0	1
SNA 4063K-A	230 V AC	Screw terminals, pluggable	R1.188.1460.0	1
SNA 4063K-C	24 V AC/DC	Push-in terminals, pluggable	R1.188.1950.0	1
SNA 4063KM-A	24 V AC/DC	Screw terminals, pluggable	R1.188.3290.0	1
SNA 4063KM-C	24 V AC/DC	Push-in terminals, pluggable	R1.188.3420.0	1
SNA 4064K-A	24 V AC/DC	Screw terminals, pluggable	R1.188.1900.0	1
SNA 4064K-A	42-48 V AC	Screw terminals, pluggable	R1.188.1910.0	1
SNA 4064K-A	115-120 V AC	Screw terminals, pluggable	R1.188.1920.0	1
SNA 4064K-A	230 V AC	Screw terminals, pluggable	R1.188.1930.0	1
SNA 4064K-C	24 V AC/DC	Push-in terminals, pluggable	R1.188.1970.0	1
SNA 4064KM-A	24 V AC/DC	Screw terminals, pluggable	R1.188.3360.0	1
SNA 4064KM-C	24 V AC/DC	Push-in terminals, pluggable	R1.188.3430.0	1

## Technical data

<b>Function</b>		Emergency stop relay
Function display		3 LEDs, green
<b>Power supply circuit</b>		
Rated voltage $U_N$	A1, A2	24 V AC/DC / 42-48 V AC / 115-120 V AC / 230 V AC
Rated consumption	24V DC / 24 V AC	1.6 W / 2.9 VA
	42-48V AC / 115-120V AC / 230 V AC	2.3 W / 2.6 VA
Rated frequency		50 - 60 Hz
Operating voltage range $U_B$		0.85 - 1.1 x $U_N$
Electrical isolation supply circuit - control circuit		yes (at $U_N = 42-48$ V AC, 115-230 V AC, 230 V) AC
<b>Control circuit</b>		
Rated output voltage	S11/S21	24 V DC
Input current / peak current	S12, S52/S22   S34	25 mA / 100 mA   5 mA / 50 mA
Response time $t_{A1}$ / $t_{A2}$		100 ms / ---
Minimum ON time $t_M$		100 ms
Recovery time $t_W$		750 ms
Release time $t_R$		10 ms
Synchronous time $t_S$		no
Permissible test pulse time $t_{TP}$		< 1 ms
Max. resistivity, per channel <sup>1)</sup>	24V AC/DC	$\leq (5 + (1,176 \times U_B / U_N - 1) \times 100) \Omega$
	42-48V AC / 115-120 V AC, 230 V AC	$\leq (5 + (1,176 \times U_B / U_N - 1) \times 100) \Omega$
<b>Output circuit</b>		
	SNA 4063K/KM	SNA 4064K/KM
Enabling paths	13/14, 23/24, 33/34	13/14, 23/24, 33/34, 43/44
Signaling paths	41/42	---
Contact assignment		normally open contact
Contact type		normally closed contact
Rated switching voltage	enabling / signaling path	forcefully guided
Max. thermal current $I_{th}$	enabling / signaling path	Ag-alloy, gold-plated
Max. total current $I^2$ of all current path	( $T_u = 55^\circ C$ ) / ( $T_u = 65^\circ C$ )	230 V AC
Application category (NO)	AC-15   DC-13	8 A / 5 A
Short-circuit protection (NO), lead fuse / circuit breaker		25 A <sup>2</sup> / 9 A <sup>2</sup>
Mechanical life		$U_o$ 230 V, $I_o$ 3 A   $U_o$ 24 V, $I_o$ 3 A
		6 A class gG / melting integral < 100 A <sup>2</sup> s
		10 <sup>7</sup> switching cycles
<b>General data</b>		
Creepage distances and clearances between the circuits		EN 60664-1
Protection degree according to EN 60529 (housing / terminals)		IP40 / IP20
Ambient temperature / storage temperature		-25 °C - +65 °C / -25 °C - +75 °C
Wire ranges screw terminals,	fine-stranded / solid	1 x 0.2 mm <sup>2</sup> - 2.5 mm <sup>2</sup> / 2 x 0.2 mm <sup>2</sup> - 1.0 mm <sup>2</sup>
	fine-stranded with ferrules	1 x 0.25 mm <sup>2</sup> - 2.5 mm <sup>2</sup> / 2 x 0.25 mm <sup>2</sup> - 1.0 mm <sup>2</sup>
Permissible torque		0.5 - 0.6 Nm
Wire ranges push-in terminals		1 x 0.25 mm <sup>2</sup> bis 1.5 mm <sup>2</sup>
Weight	24 V AC/DC device / AC device	0-21 kg / 0-25 kg
Standards		EN ISO 13849-1, EN 62061, EN 81-1, EN 50156-1, EN 61511
Approvals		TÜV, cULus, CCC, GL

<sup>1)</sup> If two-channel devices are installed as single channel, the value is halved.

# SNO 4003K

## Monitoring of emergency stop and safety gates



### Applications

- Protection of people and machinery
- Monitoring of emergency stop applications
- Monitoring of safety gates
- Up to PL d/Category 3 (EN ISO 13849-1)\*
- Up to SIL<sub>CL</sub> 2 (EN 62061)\*

### Features

- Stop Category 0 according to EN 60204-1
- Single-channel or two-channel control
- Manual or automatic start
- 3 enabling current paths, 1 signal current path
- Feedback loop for monitoring external contactors

\* PL e contact expansion

### Function

The device is a single-channel switching device for emergency stop applications with self-monitoring on each ON-OFF cycle. It complies with EN 60204-1 and is equipped with forcibly guided relays.

The device has either two Y2 reset inputs (without reset monitoring) or two Y3 reset inputs (with reset monitoring). The K1 and K2 relays are actuated either automatically (bridge Y1 Y2) or after the reset button (on Y1 Y3) has been pressed. They become self-locking through their own contacts, if there is an electrical connection between terminal A1 and the supply voltage (emergency stop button, position switches).

After this switch-on phase the enabling current paths are closed and the signaling current path is open.

If the electrical connections between terminal A1 and the supply voltage are interrupted, the enabling current paths open and the signaling current path closes. The energized state (self-locking) of the two channels is indicated by a green LED K1, K2. The second green LED indicates that supply voltage has been applied. The set-up of an emergency stop facility after stop Category 0 (EN 60204-1) is possible.

### Circuit diagram

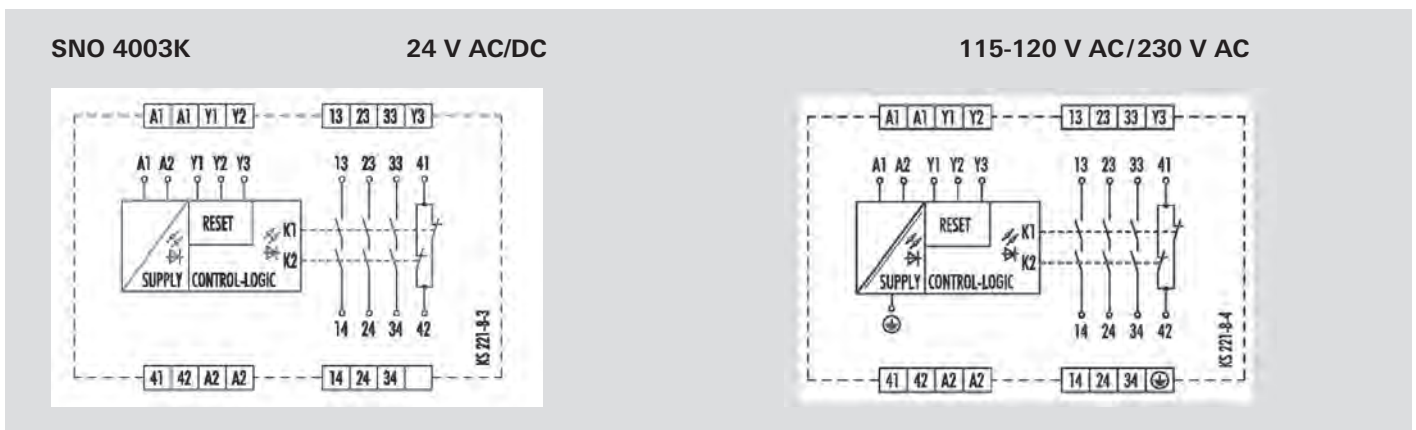

**Overview of devices | part numbers**

Type	Rated voltage	Terminals	Part no.	Std. pack
SNO 4003K-A	24 V AC/DC	Screw terminals, pluggable	R1.188.0500.1	1
	115 – 120 V AC	Screw terminals, pluggable	R1.188.0900.1	1
	230 V AC	Screw terminals, pluggable	R1.188.0910.1	1
SNO 4003K-C	24 V AC/DC	Push-in terminals, pluggable	R1.188.1990.0	1
	115 – 120 V AC	Push-in terminals, pluggable	R1.188.4000.0	1
	230 V AC	Push-in terminals, pluggable	R1.188.4010.0	1

**Technical data**

<b>Function</b>	Emergency stop relay	
Function display	2 LEDs, green	
<b>Power supply circuit</b>		
Rated voltage $U_N$	A1, A2	24 V AC/DC / 115-120 V AC / 230 V AC
Rated consumption	24 V DC	1.3 W
	115-120 V AC, 230 V AC	2.2 W / 3.9 VA
Rated frequency	50 - 60 Hz	
Operating voltage range $U_B$	0.85 - 1.1 x $U_N$	
Electrical isolation supply circuit - control circuit	yes (at $U_N = 115-120$ V AC, 230 V AC)	
<b>Control circuit</b>		
Rated output voltage	Y1	24 V DC
Input current / peak current	Y2, Y3	90 mA / 1500 mA
Response time $t_{A1} / t_{A2}$	60 ms	
Minimum ON time $t_M$ (Manueller Start)	60 ms	
Recovery time $t_W$	200 ms	
Release time $t_R$	60 ms	
Max. resistivity	24V AC/DC	$\leq (2.5 + (1.176 \times U_B / U_N - 1) \times 50) \Omega$
	115-120 V AC, 230 V AC	$\leq (7.5 + (1.176 \times U_B / U_N - 1) \times 150) \Omega$
<b>Output circuit</b>		
Enabling paths	13/14, 23/24, 33/34	
Signaling paths	41/42	normally closed contact
Contact assignment	forcefully guided	
Contact type	Ag-alloy, gold-plated	
Rated switching voltage	enabling / signaling path	230 V AC
Max. thermal current $I_{th}$	enabling / signaling path	8 A / 5 A
Max. total current $I^2$ of all current path	( $T_u = 55$ °C)	9 A <sup>2</sup>
Application category (NO)	AC-15	$U_e$ 230 V, $I_e$ 5 A
	DC-13	$U_e$ 24 V, $I_e$ 5 A
Short-circuit protection (NO), lead fuse / circuit breaker	6 A class gG / melting integral < 100 A <sup>2</sup> s	
Mechanical life	10 <sup>7</sup> switching cycles	
<b>General data</b>		
Creepage distances and clearances between the circuits	EN 60664-1	
Protection degree according to EN 60529 (housing / terminals)	IP40 / IP20	
Ambient temperature / storage temperature	-25 °C - +55 °C / -25 °C - + 75 °C	
Wire ranges screw terminals,	fine-stranded / solid	1 x 0.2 mm <sup>2</sup> – 2.5 mm <sup>2</sup> / 2 x 0.2 mm <sup>2</sup> – 1.0 mm <sup>2</sup>
	fine-stranded with ferrules	1 x 0.25 mm <sup>2</sup> – 2.5 mm <sup>2</sup> / 2 x 0.25 mm <sup>2</sup> – 1.0 mm <sup>2</sup>
Permissible torque	0.5 - 0.6 Nm	
Wire ranges push-in terminals	1 x 0.25 mm <sup>2</sup> – 1.5 mm <sup>2</sup>	
Weight	24 V AC/DC device / AC device	0.20 kg / 0.25 kg
Standards	EN ISO 13849-1, EN 62061	
Approvals	DGUV, cULus, CCC	

# SNO 1012K

## Monitoring of emergency stop and safety gates



### Applications

- Protection of people and machinery
- Monitoring of emergency stop applications
- Monitoring of safety gates
- Up to PL d/Category 3 (EN ISO 13849-1)
- Up to SIL<sub>CL</sub> 2 (EN 62061)

### Features

- Stop Category 0 according to EN 60204-1
- Single-channel or two-channel control
- Manual or automatic start
- 2 enabling current paths
- Check of external contactors (EDM)
- Compact design

### Function

After the operating voltage (L+/L1) is applied via an unactuated emergency stop button or safety gate contact on A1 and A2, the device can be switched on via a Y1/Y2-connected reset button. When the device is on, the internal relays K1 and K2 are energized and the enabling current paths 13/14 and 23/24 are closed. When the emergency stop button or the safety gate contact is actuated, the current supply of the internal relays is interrupted and the enabling current paths are opened.

### Circuit diagram

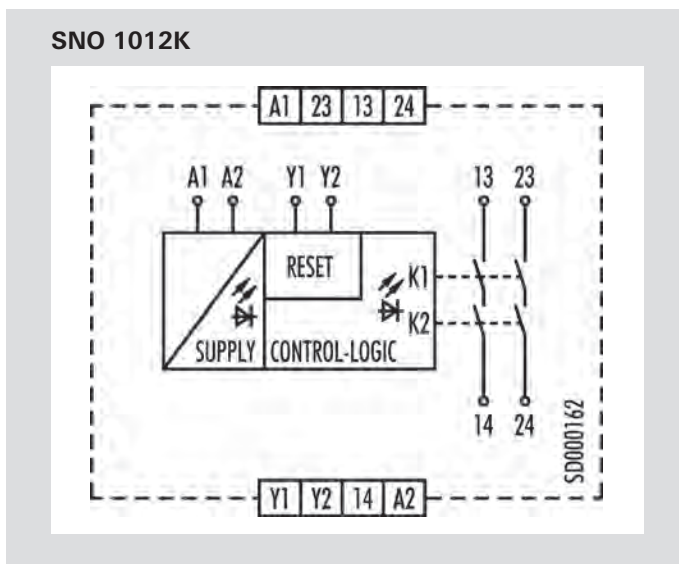

## Overview of devices | part numbers

Type	Rated voltage	Terminals	Part no.	Std. pack
SNO 1012K-A	24 V AC/DC	Screw terminals, pluggable	R1.188.3740.0	1
SNO 1012K-C	24 V AC/DC	Push-in terminals, pluggable	R1.188.3750.0	1

## Technical data

<b>Function</b>	Emergency stop relay	
Function display	2 LEDs, green	
<b>Power supply circuit</b>		
Rated voltage $U_N$	A1, A2	24 V AC/DC
Rated consumption	24 V DC	1 W / 2 VA
Rated frequency	50 - 60 Hz	
Operating voltage range $U_B$	0.85 - 1.1 x $U_N$	
Electrical isolation supply circuit - control circuit	no	
<b>Control circuit</b>		
Rated output voltage	Y1	24 V DC
Input current / peak current	Y2	50 mA / 70 mA
Response time $t_{A1}$ / $t_{A2}$	< 20 ms / < 70 ms	
Minimum ON time $t_M$	30 ms	
Recovery time $t_W$	> 200 ms	
Release time $t_R$	< 70 ms	
Max. resistivity	$\leq (2.5 + (1.176 \times U_B / U_N - 1) \times 50) \Omega$	
<b>Output circuit</b>		
Enabling paths	13/14, 23/24	normally open contact
Contact assignment	forcebly guided	
Contact type	Ag-alloy, gold-plated	
Rated switching voltage	240 V AC / 50V DC	
Max. thermal current $I_{th}$	enabling path	6 A
Max. total current $I^2$ of all current path	( $T_u = 55^\circ\text{C}$ )	72 A <sup>2</sup> / 9 A <sup>2</sup>
Application category (NO)	AC-15	$U_b$ 230 V, $I_b$ 3 A
	DC-13	$U_b$ 24 V, $I_b$ 3 A
Short-circuit protection (NO), lead fuse / circuit breaker	6 A class gG / melting integral < 100 A <sup>2</sup> s	
Mechanical life	10 x 10 <sup>6</sup> switching cycles	
<b>General data</b>		
Creepage distances and clearances between the circuits	EN 60664-1	
Protection degree according to EN 60529 (housing / terminals)	IP40 / IP20	
Ambient temperature / storage temperature	-25 °C - +55 °C / -25 °C - + 75 °C	
Wire ranges screw terminals,	fine-stranded / solid	1 x 0.2 mm <sup>2</sup> – 2.5 mm <sup>2</sup> / 2 x 0.2 mm <sup>2</sup> – 1.0 mm <sup>2</sup>
	fine-stranded with ferrules	1 x 0.25 mm <sup>2</sup> – 2.5 mm <sup>2</sup> / 2 x 0.25 mm <sup>2</sup> – 1.0 mm <sup>2</sup>
Permissible torque	0.5 - 0.6 Nm	
Wire ranges push-in terminals	2 x 0.25 mm <sup>2</sup> – 1.5 mm <sup>2</sup>	
Weight	0.12 kg	
Standards	EN ISO 13849-1, EN 62061	
Approvals	DGUV, cULus, CCC	

# SNS 4074K / SNS 4084K Standstill monitor



## Standstill monitoring function

The SNS 4084K standstill monitor provides for the safe monitoring of the frequency of a signal at inputs I1 to I4 of the device. If the frequency of the impulses is higher than the frequency set at the rotary switches (0.1 – 99 Hz), outputs Q1/Q2 will switch off. This monitoring function can be used to detect the standstill or a lower, safer rotational speed of a machine.

In applications of this sort, a spring-actuated or magnet-actuated tumbler of an electric interlocking device, for example, can be controlled from the output of the device.

The sensors for the detection of movement can, for example, be two inductive proximity switches or a rotary encoder connected to inputs I1 - I4. The frequency of the impulses to be monitored is set at the two rotary switches and splitter input T1, and is stored in the device on which the ENTER button is pressed while the voltage is applied to the device.

## Circuit diagram

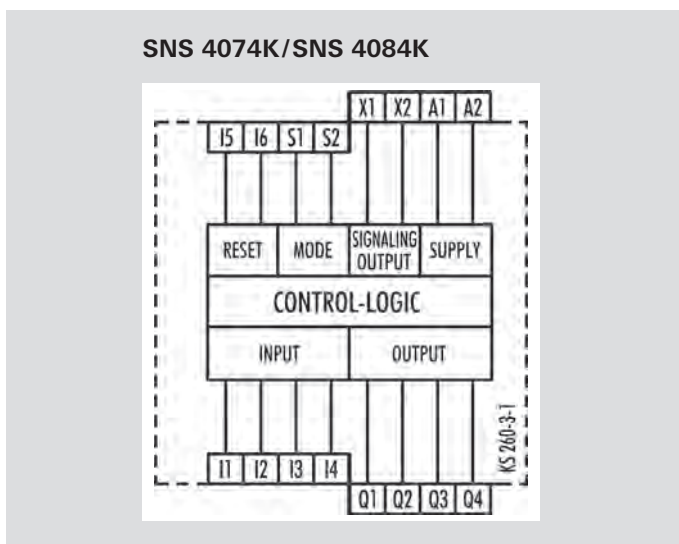

## Applications

- Standstill monitoring
- Monitoring of electrical lockout devices
- Control of spring-actuated tumblers
- Monitoring of low rotational speeds in setup operation
- Up to PL e/Category 4 (EN ISO 13849-1)
- Up to SIL<sub>CL</sub> 3 (EN 62061)

## Features

- Reliable monitoring of dynamic input signals
- Adjustable monitoring frequency 0.1 – 99 Hz
- 4 selectable operating mode groups
- Single-channel or two-channel control
- Manual or automatic start
- Cross monitoring
- 4 safe semi-conductor outputs

## SNS 4074K

The device features a bypass input, which allows safety-oriented bypassing of the monitoring function, e.g. when a safe position has been reached. In this case, the signal must fulfill at least the safety category of the selected monitoring function.

## SNS 4084K

The device features an input for the implementation of a start override, which allows the safe outputs to be switched off even during machine standstill. This means, for example, that a spring-activated protective locking facility can be activated during machine start-up.

Terminals	Description
A1	+ 24 V
A2	GND
X1 / X2	Signal output, semi-conductor (plus switching)
S1	Configuration input for operating mode group
S2	Configuration input for operating mode group
I1	Sensor input
I2	Sensor / configuration input (depending on the operating mode group)
I3	Sensor / configuration input (depending on the operating mode group)
I4	Sensor / configuration input (depending on the operating mode group)
I5	Reset input
I6	Bypass input (SNS 4074K) / start override input (SNS 4084K)
Q1 / Q2	Safe Output, semi-conductor (plus switching)
Q3 / Q4	Safe Output, semi-conductor (plus switching), inverted

## Overview of devices | part numbers

Type	Frequency range	Terminals	Part no.	Std. pack
SNS 4074K-A	0.5 - 99 Hz	Screw terminals, pluggable	R1.188.3640.0	1
SNS 4074K-C	0.5 - 99 Hz	Push-in terminals, pluggable	R1.188.3650.0	1
SNS 4074K-A	0.1 - 9.9 Hz	Screw terminals, pluggable	R1.188.3620.0	1
SNS 4074K-C	0.1 - 9.9 Hz	Push-in terminals, pluggable	R1.188.3630.0	1
SNS 4084K-A	0.5 - 99 Hz	Screw terminals, pluggable	R1.188.3480.0	1
SNS 4084K-C	0.5 - 99 Hz	Push-in terminals, pluggable	R1.188.3490.0	1
SNS 4084K-A	0.1 - 9.9 Hz	Screw terminals, pluggable	R1.188.3660.0	1
SNS 4084K-C	0.1 - 9.9 Hz	Push-in terminals, pluggable	R1.188.3670.0	1

## Function diagram

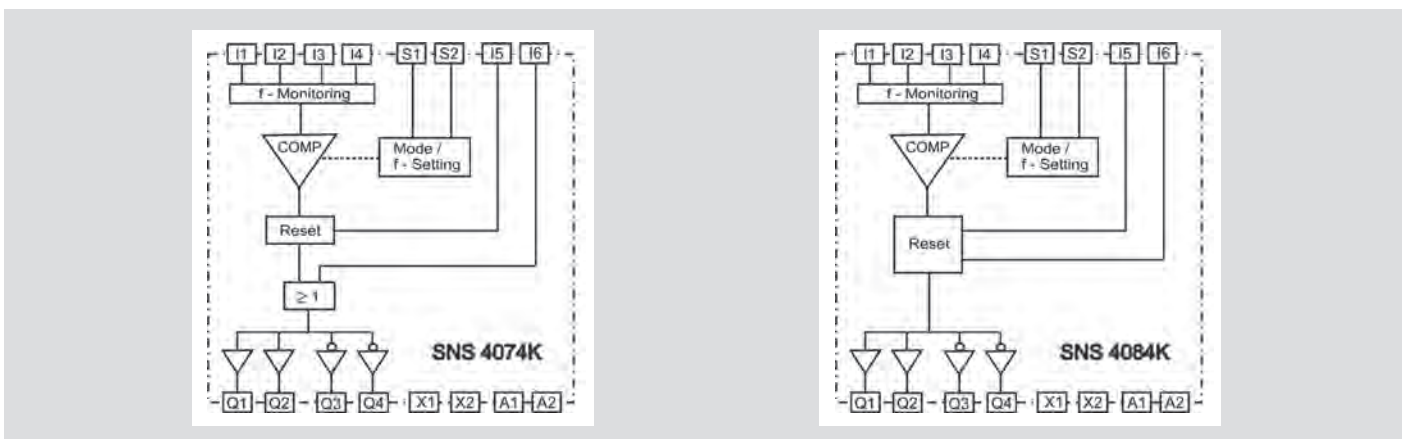

## Technical data

<b>Function</b>		Standstill monitoring
Function display		12 LEDs, green/red
Function mode / adjustment		Frequency monitoring / 2 x-position switch
Adjustment range	$f_{ST}$	0,1 - 99 Hz / 0,5 - 99 Hz
<b>Power supply circuit</b>		
Rated voltage $U_N$	A1, A2	24 V DC
Rated consumption	24 V DC	1.8 W
Operating voltage range $U_B$		0.85 - 1.1 x $U_N$
Electrical isolation supply circuit - control circuit		no
<b>Control circuit</b>		
Rated output voltage		24 V DC
Input current / peak current	I1 - I6, S1, S2	3 mA / 3,8 mA
Minimum ON time $t_M$		100 ms (< 5 s)
Release time $t_R$		12 ms + 1.6 / $f_{ST}$
Max. cable length per input		100 m
<b>Output circuit</b>		
Enabling paths	Q1, Q2, Q3, Q4	Semi-conductor (plus switching), safety-related
Signaling paths	X1, X2	Semi-conductor (plus switching), not safety-related
Rated switching voltage	enabling path	30 V DC
Max. thermal current $I_{th}$	enabling path	2 A
Max. total current $I^2$ of all current path	( $T_u = 55^\circ C$ )	4 A
Mechanical life		Must be short-circuit proof
<b>General data</b>		
Creepage distances and clearances between the circuits		EN 60664-1
Protection degree according to EN 60529 (housing / terminals)		IP40 / IP20
Ambient temperature / storage temperature		-25 °C - +55 °C / -25 °C - + 75 °C
Wire ranges screw terminals,	fine-stranded / solid	1 x 0.2 mm <sup>2</sup> - 2.5 mm <sup>2</sup> / 2 x 0.2 mm <sup>2</sup> - 1.0 mm <sup>2</sup>
	fine-stranded with ferrules	1 x 0.25 mm <sup>2</sup> - 2.5 mm <sup>2</sup> / 2 x 0.25 mm <sup>2</sup> - 1.0 mm <sup>2</sup>
Permissible torque		0.5 - 0.6 Nm
Wire ranges push-in terminals		1 x 0.25 mm <sup>2</sup> - 1.5 mm <sup>2</sup>
Weight		0.16 kg
Standards		EN ISO 13849-1, EN 62061
Approvals		TÜV, cULus

# SVM 4001K Standstill monitor



## Applications

- Standstill monitoring
- Monitoring of electrical lockout devices
- Control of spring-actuated tumblers
- Monitoring of low rotational speeds in setup operation
- Up to PL e/Category 4 (EN ISO 13849-1)
- Up to SIL<sub>CL</sub> 3 (EN 62061)

## Features

- Sensorless monitoring of 1-phase and 3-phase motors
- Safe, configurable voltage monitoring
- Automatic operation

## Function

The SVM 4001K device monitors machines, the 3-phase powered drive units of which have no movement detection sensors. When the drives are set in motion or if faults are detected, the standstill monitor relay assumes the rest position.

## Application

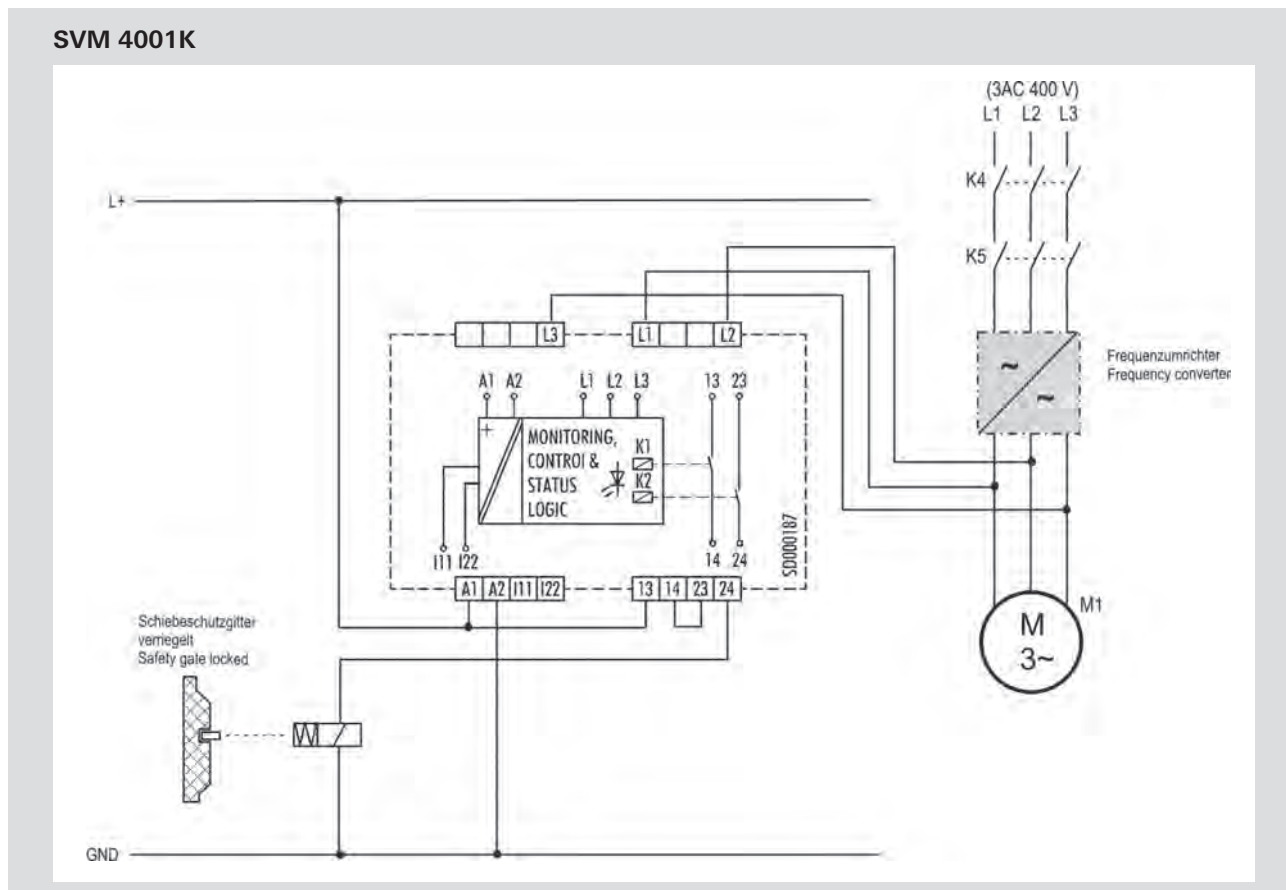

## Overview of devices | part numbers

Type	Frequency range	Terminals	Part no.	Std. pack
SVM 4001K-A	24 V DC	Screw terminals, pluggable	R1.188.4020.0	1
SVM 4001K-C	24 V DC	Push-in terminals, pluggable	R1.188.4030.0	1

## Circuit diagram

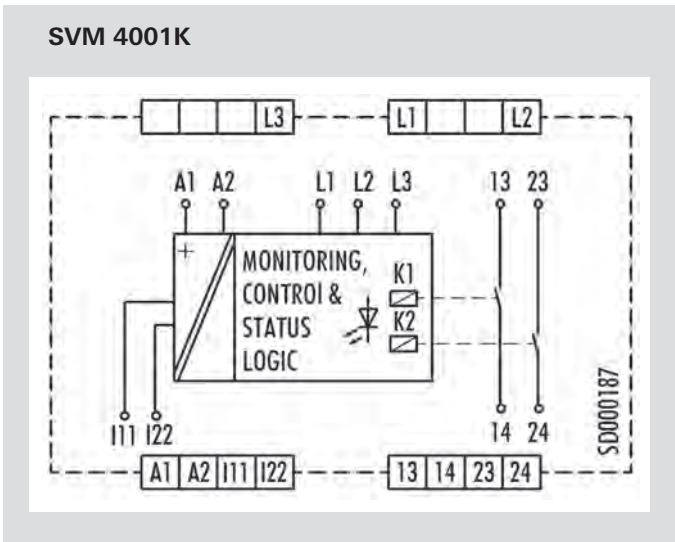

## Technical data

<b>Function</b>	Standstill monitoring	
Function display	4 LED, green/red	
Function mode / adjustment	Voltage measurement	
Adjustment range	50 - 500 mV	
<b>Power supply circuit</b>		
Rated voltage $U_N$	A1, A2	24 V DC
Rated consumption	24 V DC	1.8 W
Operating voltage range $U_B$	0.85 - 1.1 x $U_N$	
<b>Control circuit</b>		
Rated output voltage	U, V, W	690 V AC3
Response time $t_A$	20 ms	
Release time $t_R$	20 ms	
<b>Output circuit</b>		
Enabling paths	13/14, 23/24	normally open contact
Contact assignment	forcibly guided	
Contact type	Ag-alloy	
Rated switching voltage	230 V AC	
Max. thermal current $I_{th}$	8 A	
Application category (NO)	AC-15	$U_o$ 230 V, $I_o$ 3 A
	DC-13	$U_o$ 24 V, $I_o$ 4 A
Short-circuit protection (NO), lead fuse / circuit breaker	5 A class gG	
Mechanical life	20 x 10 <sup>6</sup> switching cycles	
<b>General data</b>		
Creepage distances and clearances between the circuits	EN 60664-1	
Protection degree according to EN 60529 (housing / terminals)	IP40 / IP20	
Ambient temperature / storage temperature	-20 °C - +55 °C / -40 °C - + 85 °C	
Wire ranges screw terminals,	fine-stranded / solid	1 x 0.2 mm <sup>2</sup> - 2.5 mm <sup>2</sup> / 2 x 0.2 mm <sup>2</sup> - 1.0 mm <sup>2</sup>
	fine-stranded with ferrules	1 x 0.25 mm <sup>2</sup> - 2.5 mm <sup>2</sup> / 2 x 0.25 mm <sup>2</sup> - 1.0 mm <sup>2</sup>
Permissible torque	0.5 - 0.6 Nm	
Wire ranges push-in terminals	1 x 0.25 mm <sup>2</sup> - 1.5 mm <sup>2</sup>	
Weight	0.180 kg	
Standards	EN ISO 13849-1, EN 62061	
Approvals	TÜV, cULus	

# SNT 4M63K

## Monitoring of emergency stop and safety gates

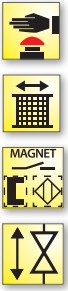

### Applications

- Protection of people and machinery
- Monitoring of emergency stop applications
- Monitoring of safety gates
- Up to PL e/Category 4 (EN ISO 13849-1)
- Up to SIL<sub>CL</sub> 3 (EN 62061)

### Features

- Stop Category 0 according to EN 60204-1
- Manual or automatic start
- Cross monitoring
- 3 enabling current paths (NO contact, forcibly guided)
- Feedback loop for monitoring external contactors

### Function

The device is a two-channel switching device with self-monitoring on each ON-OFF cycle. It complies with EN 60204-1 and is equipped with forcibly guided relays. It is intended for monitoring connected switching elements on separating safety devices and generating a safety-oriented signal (enable). Depending on the design, separating safety devices may include sliding safety gates, safety gates, housings, covers, sheetings, screens, etc.

### Basic function

With supply voltage applied to terminals A1/A2 and the safety inputs closed, pressing the reset button closes the enabling current paths (manual start). When the safety inputs are opened the enabling paths will open.

- **Manual start** – When the safety inputs are closed, a button is used to close reset input S34 and open it again (triggering with falling edge) or to close reset input S35 (triggering with rising edge).
- **Automatic Start** – Reset input S35 is connected to S33/S14. The device starts with the rising edge of the signal on safety input S14.

### Circuit diagram

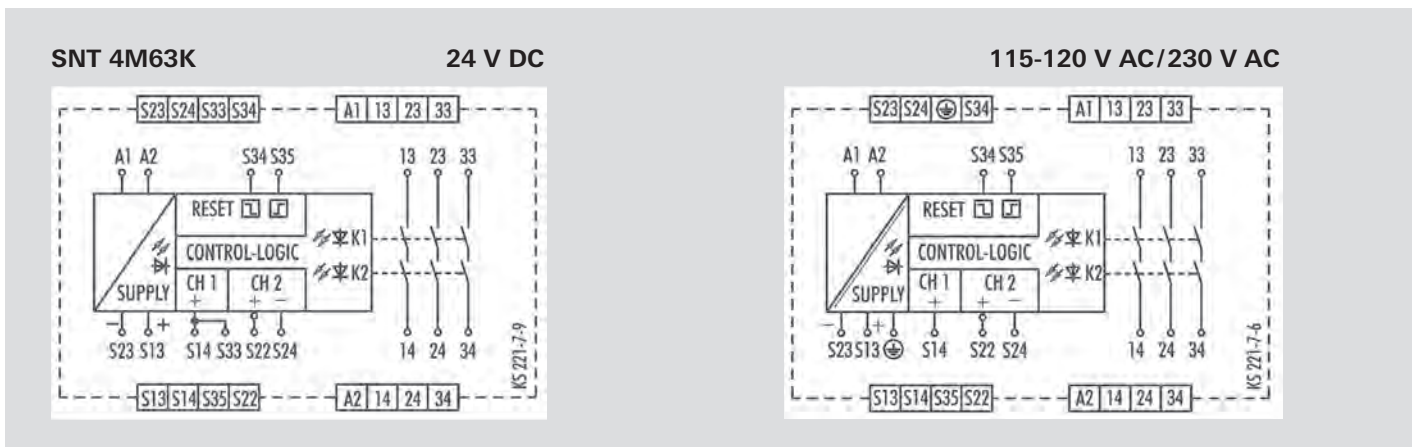

## Overview of devices | part numbers

Type	Rated voltage	Terminals	Part no.	Std. pack
SNT 4M63K-A	24 V AC/DC	Screw terminals, pluggable	R1.188.1050.0	1
	115 – 120 V AC	Screw terminals, pluggable	R1.188.1060.0	1
	230 V AC	Screw terminals, pluggable	R1.188.1070.0	1
SNT 4M63K-C	24 V AC/DC	Push-in terminals, pluggable	R1.188.2390.0	1

## Technical data

<b>Function</b>	Emergency stop relay, valve position and safety gate monitoring	
Function display	3 LEDs, green	
<b>Power supply circuit</b>		
Rated voltage $U_N$	A1, A2	24 V AC/DC, 115-120 V AC, 230 V AC
Rated consumption	24 V DC	2.0 W
	115-120 V AC, 230 V AC	2,6 W / 3.2 VA
Rated frequency	50 - 60 Hz	
Operating voltage range $U_B$	0.85 - 1.1 x $U_N$	
Electrical isolation supply circuit - control circuit	yes (at $U_N = 115-230$ V AC, 230 V AC)	
<b>Control circuit</b>		
Rated output voltage	S13/S23	22 V DC
Input current / peak current	S14/S33, S22/S24	40 mA / 100 mA
	S34, S35	5 mA / 50 mA
Response time $t_{A1} / t_{A2}$	40 ms / 600 ms	
Minimum ON time $t_M$	80 ms	
Recovery time $t_W$	100 ms	
Release time $t_R$	15 ms	
Synchronous time $t_S$	200 ms (CH1 → CH2)	
Max. resistivity, per channel <sup>1)</sup>	24 V AC/DC	$\leq (5 + (1.176 \times U_B / U_N - 1) \times 100) \Omega$
	115-120 V AC, 230 V AC	$\leq (5 + (1.176 \times U_B / U_N - 1) \times 100) \Omega$
<b>Output circuit</b>		
Enabling paths	13/14, 23/24, 33/34	normally open contact
Contact assignment	forcefully guided	
Contact type	Ag-alloy, gold-plated	
Rated switching voltage	enabling path	230 V AC
Max. thermal current $I_{th}$	enabling path	6 A
Max. total current $I^2$ of all current path	( $T_u = 55$ °C)	9 A <sup>2</sup>
Application category (NO)	AC-15	$U_e$ 230 V, $I_e$ 3 A
	DC-13	$U_e$ 24 V, $I_e$ 2.5 A
Short-circuit protection (NO), lead fuse / circuit breaker	6 A class gG / melting integral < 100 A <sup>2</sup> s	
Mechanical life	10 <sup>7</sup> switching cycles	
<b>General data</b>		
Creepage distances and clearances between the circuits	EN 60664-1	
Protection degree according to EN 60529 (housing / terminals)	IP40 / IP20	
Ambient temperature / storage temperature	-25 °C - +55 °C / -25 °C - + 75 °C	
Wire ranges screw terminals,	fine-stranded / solid	1 x 0.2 mm <sup>2</sup> – 2.5 mm <sup>2</sup> / 2 x 0.2 mm <sup>2</sup> – 1.0 mm <sup>2</sup>
	fine-stranded with ferrules	1 x 0.25 mm <sup>2</sup> – 2.5 mm <sup>2</sup> / 2 x 0.25 mm <sup>2</sup> – 1.0 mm <sup>2</sup>
Permissible torque	0.5 - 0.6 Nm	
Wire ranges push-in terminals	1 x 0.25 mm <sup>2</sup> – 1.5 mm <sup>2</sup>	
Weight	0-21 kg / 0-25 kg	
Standards	EN ISO 13849-1, EN 62061	
Approvals	DGUV, cULus, CCC	

<sup>1)</sup> If two-channel devices are installed as single channel, the value is halved.

# SNZ 4052K

## Two-hand relay type IIIC



### Applications

- Protection of people and machinery
- Monitoring of two-hand applications
- Monitoring of safety gates
- According to EN 574 Type IIIC
- Up to PL e/Category 4 (EN ISO 13849-1)
- Up to SIL<sub>CL</sub> 3 (EN 62061)

### Features

- Stop Category 0 according to EN 60204-1
- Two-channel actuation; 1 NO contact and 1 NC contact for each channel
- Cross monitoring
- Monitoring of synchronous activation
- 2 enabling current paths, 1 signaling current path

### Function

The device complies with EN 574 Type III C safety requirements. The safety behavior of the device is designed for applications according to Category 4 (EN 954-1). The device is single-fault safe and self-monitoring. Synchronous activation of both actuators (two-hand momentary contact or safety gate contacts) is monitored. Each of the two actuators is connected to the device with an NO contact and an NC contact. The technical design of the input circuit provides cross connection and ground fault monitoring. The output function is designed with 2 NO contacts as an enabling current path and 1 NC contact as signaling current path (all forcibly guided).

With supply voltage applied to terminals A1/A2 and the feedback loop (terminals Y1/Y2) closed, the enabling current paths are closed by simultaneously activating the actuators (S1+S2). Both actuators must be activated within 0.5 s for the

output contacts to be enabled. If only one of the two actuators is released, the device is immediately de-energized. The enabling current paths open.

The device can be restarted only after both actuators have returned to their initial position (for example when the two-hand momentary contact switches have been released) and the feedback circuit is closed again. The feedback circuit should only be opened again after both actuators are activated. Otherwise the device will remain in the OFF position. The current status of the device is indicated by 3 LEDs: application of the supply voltage with LED SUPPLY, activation of both actuators with LED K1 and additionally with LED K2 in case of synchronous activation.

### Circuit diagram

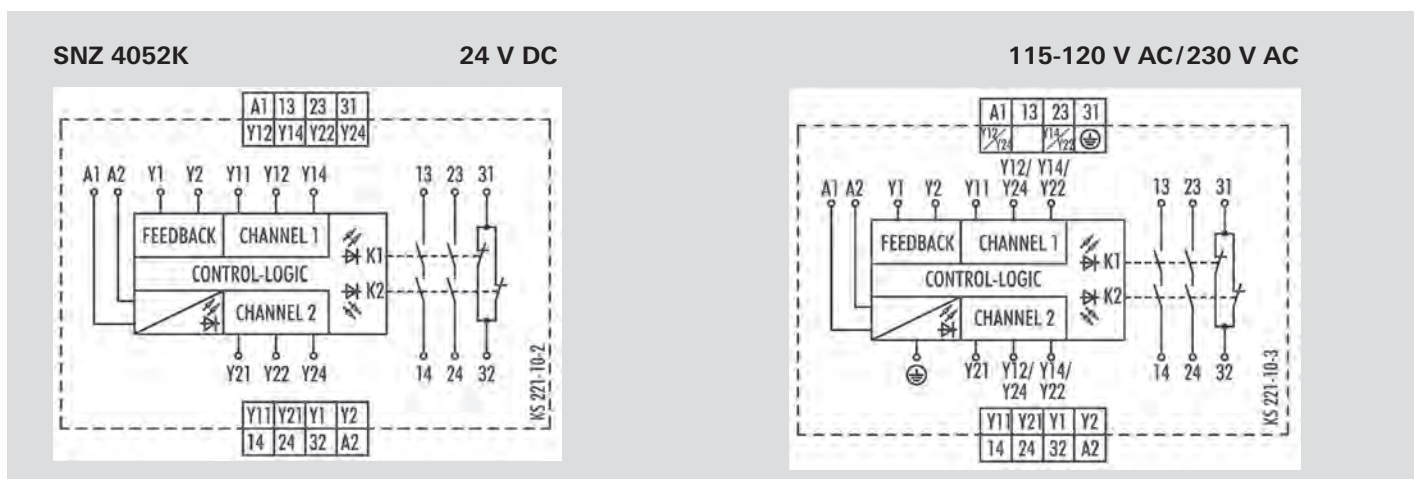

## Overview of devices | part numbers

Type	Rated voltage	Terminals	Part no.	Std. pack
SNZ 4052K-A	24 V AC/DC	Screw terminals, pluggable	R1.188.0530.1	1
	115 – 120 V AC	Screw terminals, pluggable	R1.188.0940.1	1
	230 V AC	Screw terminals, pluggable	R1.188.0950.1	1
SNZ 4052K-C	24 V AC/DC	Push-in terminals, pluggable	R1.188.2020.0	1

## Technical data

<b>Function</b>	Two-hand control relay	
Function display	3 LEDs, green	
<b>Power supply circuit</b>		
Rated voltage $U_N$	A1, A2	24 V AC/DC, 115-120 V AC, 230 V AC
Rated consumption	24 V DC	2.4 W
	115-120 V AC, 230 V AC	2.2 W / 3.1 VA
Rated frequency	50 - 60 Hz	
Operating voltage range $U_B$	0.85 - 1.1 x $U_N$	
Electrical isolation supply circuit - control circuit	yes (at $U_N = 115-230$ V AC, 230 V AC)	
<b>Control circuit</b>		
Rated output voltage	Y12/Y14, Y22/Y24, Y1	24 V DC
Input current / peak current	Y11, Y21	60 mA / 1000 mA
	Y2	< 100 mA
Response time $t_{A1} / t_{A2}$	40 ms	
Recovery time $t_W$	250 ms	
Release time $t_R$	50 ms	
Synchronous time $t_S$	≤ 500 ms	
Max. resistivity, per channel	24 V AC/DC	≤ (2.5 + (1.176 x $U_B / U_N - 1$ ) x 50) Ω
	115-120 V AC, 230 V AC	≤ (2.5 + (1.176 x $U_B / U_N - 1$ ) x 50) Ω
<b>Output circuit</b>		
Enabling paths	13/14, 23/24	normally open contact
Signaling paths	31/32	normally closed contact
Contact assignment	forcefully guided	
Contact type	Ag-alloy, gold-plated	
Rated switching voltage	enabling / signaling path	230 V AC
Max. thermal current $I_{th}$	enabling / signaling path	6 A / 2 A
Max. total current $I^2$ of all current path	( $T_u = 55$ °C)	9 A <sup>2</sup>
Application category (NO)	AC-15	$U_e$ 230 V, $I_e$ 3 A
	DC-13	$U_e$ 24 V, $I_e$ 2.5 A
Short-circuit protection (NO), lead fuse / circuit breaker	6 A class gG / melting integral / < 100 A <sup>2</sup> s	
Mechanical life	10 <sup>7</sup> switching cycles	
<b>General data</b>		
Creepage distances and clearances between the circuits	EN 60664-1	
Protection degree according to EN 60529 (housing / terminals)	IP40 / IP20	
Ambient temperature / storage temperature	-25 °C - +55 °C / -25 °C - +75 °C	
Wire ranges screw terminals,	fine-stranded / solid	1 x 0.2 mm <sup>2</sup> – 2.5 mm <sup>2</sup> / 2 x 0.2 mm <sup>2</sup> – 1.0 mm <sup>2</sup>
	fine-stranded with ferrules	1 x 0.25 mm <sup>2</sup> – 2.5 mm <sup>2</sup> / 2 x 0.25 mm <sup>2</sup> – 1.0 mm <sup>2</sup>
Permissible torque	0.5 - 0.6 Nm	
Wire ranges Push-in terminals	1 x 0.25 mm <sup>2</sup> – 1.5 mm <sup>2</sup>	
Weight	0.20 kg / 0.25 kg	
Standards	EN ISO 13849-1, EN 62061, EN 574	
Approvals	DGUV, cULus, CCC	

# SNZ 1022K

## Two-hand relay type IIIA



### Applications

- Protection of people and machinery
- Monitoring of two-hand applications
- Monitoring of safety gates
- According to EN 574 Type IIIA
- Up to PL c/Category 1 (EN ISO 13849-1)
- Up to SIL<sub>CL</sub> 1 (EN 62061)

### Features

- Stop Category 0 according to EN 60204-1
- Two-channel actuation; 1 NO contact and 1 NC contact for each channel
- Cross monitoring
- Monitoring of synchronous activation
- 1 changeover contact

### Function

After the power supply is established at terminals A1/A2 the release current paths are closed when the actuators (S1+S2) are operated at the same time. The two actuators must be operated within 0.5 s to trigger a release. If just one of the two actuators is released, the device is immediately de-energized and the enabling current path is opening.

The device can only be restarted once the two actuators are returned to their initial positions (e.g. the two-hand buttons have been released). The current status of the device is shown by 2 LEDs. The presence of the power supply is indicated with the SUPPLY LED, the operation of the two actuators with the K1 LED, if there is synchronous operation.

### Circuit diagram

SNZ 1022K

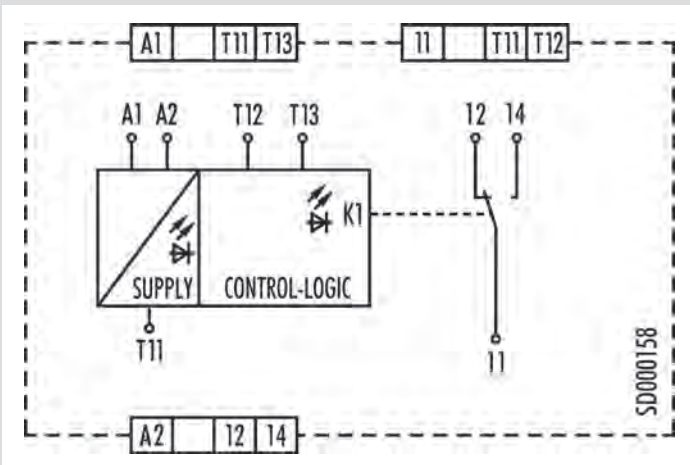

## Overview of devices | part numbers

Type	Rated Voltage	Synchronous time	Terminals	Part no.	Std. pack
SNZ 1022K-A	24 V AC/DC	0.5 s	Screw terminals, pluggable	R1.188.3700.0	1
SNZ 1022K-A	115-230 V AC	0.5 s	Screw terminals, pluggable	R1.188.3710.0	1
SNZ 1022K-C	24 V AC/DC	0.5 s	Push-in terminals, pluggable	R1.188.3720.0	1
SNZ 1022K-C	115-230 V AC	0.5 s	Push-in terminals, pluggable	R1.188.3730.0	1

## Technical data

<b>Function</b>	Two-hand control relay	
Function display	2 LEDs, green	
<b>Power supply circuit</b>		
Rated voltage $U_N$	A1, A2	24 V AC/DC / 115-230 V AC
Rated consumption	AC/DC 24 V	0.7 W / 2.0 VA
	AC 115-230 V	3 VA
Rated frequency	50 - 60 Hz	
Operating voltage range $U_B$	0.85 - 1.1 x $U_N$	
Electrical isolation supply circuit - control circuit	yes (at $U_N = 115-230$ V AC)	
<b>Control circuit</b>		
Rated output voltage	T11	24 V DC
Input current / peak current	T12	2.5 mA / 3 mA
	T13	25 mA / 60 mA
Response time $t_{A1} / t_{A2}$	< 20 ms	
Recovery time $t_W$	> 250 ms	
Release time $t_R$	< 20 ms	
Synchronous time $t_S$	≤ 500 ms	
Max. resistivity, per channel	$(5 + (1.176 \times U_B / U_N - 1) \times 100) \Omega$	
<b>Output circuit</b>		
Enabling paths	11/12/14	changeover contact
Contact type	Ag-alloy, gold-plated	
Rated switching voltage	230 V AC	
Max. thermal current $I_{th}$	enabling path 10/12	6 A
Application category (NO)	AC-15	$U_o$ 230 V, $I_o$ 3 A
	DC-13	$U_o$ 24 V, $I_o$ 2 A
Short-circuit protection (NO), lead fuse / circuit breaker	6 A class gG / melting integral < 100 A <sup>2</sup> s	
Mechanical life	10 x 10 <sup>6</sup> switching cycles	
<b>General data</b>		
Creepage distances and clearances between the circuits	EN 60664-1	
Protection degree according to EN 60529 (housing / terminals)	IP40 / IP20	
Ambient temperature / storage temperature	-25 °C - +55 °C / -25 °C - + 75 °C	
Wire ranges screw terminals,	fine-stranded / solid	1 x 0.2 mm <sup>2</sup> – 2.5 mm <sup>2</sup> / 2 x 0.2 mm <sup>2</sup> – 1.0 mm <sup>2</sup>
	fine-stranded with ferrules	1 x 0.25 mm <sup>2</sup> – 2.5 mm <sup>2</sup> / 2 x 0.25 mm <sup>2</sup> – 1.0 mm <sup>2</sup>
Permissible torque	0.5 - 0.6 Nm	
Wire ranges push-in terminals	2 x 0.25 mm <sup>2</sup> – 1.5 mm <sup>2</sup>	
Weight	24 V AC/DC device / AC device	0.1 kg
Standards	EN ISO 13849-1, EN 62061, EN 574	
Approvals	TÜV, cULus, CCC	

# SNV 4063KL – Monitoring of emergency stop, safety gates and light barriers, OFF-delayed



## Applications

- Protection of people and machinery
- Monitoring of emergency stop applications
- Monitoring of safety gates
- Monitoring of light barriers
- Termination of braking operations through OFF-delay time
- Control of solenoid-actuated interlocks
- Up to PL e/Category 4 (EN ISO 13849-1) for undelayed contacts
- Up to PLd/Category 3 (EN ISO 13849-1) for delayed contacts
- Up to SILCL 3 (EN 62061)

## Features

- Stop category 0/1 according to EN 60204-1
- Single-channel or two-channel control
- Manual or automatic start
- OFF-delay time adjustable in the range 0.15 to 3s or 1.5 to 30s
- Reset button monitoring, cross monitoring, monitoring of synchronous time
- 3 enabling current paths (2 undelayed, 1 OFF-delayed)

## Function

With the supply voltage applied to terminals A1/A2 and the emergency stop right and left margins in-line button. This controls relays K1 to K4, which become self-locking (when starting via reset button monitoring after the response time). After this switch-on phase the 3 enabling current paths are closed (terminals 13/14, 23/24 and 37/38). Three LEDs display the state of relays K1/K2, K3/K4 and the supply voltage.

If the emergency stop button is activated, the current supplies for relays K1 to K4 are interrupted. The undelayed enabling current paths (terminals 13/14, 23/24) are opened with release time  $t_{R1}$  while the off-delayed enabling current path (terminals 37/38) is opened after the pre-set OFF-delay time  $t_{R2}$ . The OFF-delay time can be adjusted infinitely in the range 0.15 to 3 s or 1.5 to 30 s.

With a two-channel control and cross-monitoring wiring of the sensor circuit, additional errors such as short-circuit or ground fault can be detected. An electronic fuse protects the device against damage. After the cause of the malfunction has been removed, the device is operational again after approx. 3 s.

- **Reset button monitoring** – The device can be started either with the falling edge or with the rising edge (terminals S34 or S35). For emergency stop applications with manual start the button must be connected to terminals S33/S34. The device is enabled only with the falling edge of the reset signal. For starting, the reset button must be pressed and released. For safety gate applications in which an automatic start is performed it is necessary to bridge terminals S33/S35. The device will react at the rising edge of input S12 which is internally connected to S33.
- **Monitoring of synchronous time** – The use of safety limit switches for single-channel or two-channel circuits in safety gate applications depends on the required safety level. The device provides a monitoring of the synchronous time of two connected safety switches. A synchronous time  $t_s \approx 0.5$  s requires limit switches positioned in such a way that channel 1, terminals S11/S12, closes before channel 2, terminals S21/S22. If channel 2 closes before channel 1, the synchronous time is  $t_s = \infty$ .

## Circuit diagram

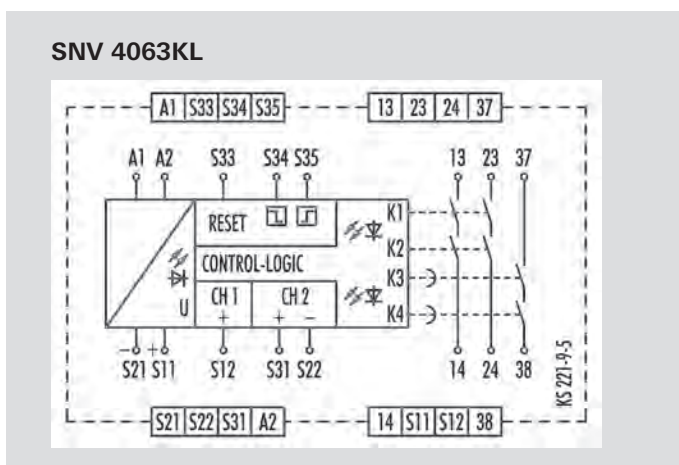

## Overview of devices | part numbers

Type	Time range	Rated voltage	Terminals	Part no.	Std. pack
SNV 4063KL-A	3 s	24 V DC	Screw terminals, pluggable	R1.188.0620.0	1
	30 s	24 V DC	Screw terminals, pluggable	R1.188.0640.0	1
	150 s	24 V DC	Screw terminals, pluggable	R1.188.4100.0	1
SNV 4063KL-C	3 s	24 V DC	Push-in terminals, pluggable	R1.188.2010.0	1
	30 s	24 V DC	Push-in terminals, pluggable	R1.188.3900.0	1

## Technical data

<b>Function</b>	Emergency stop relay for controlled stop	
Function display	3 LEDs, green	
Function mode / adjustment	Time / stepless	
Adjustment range	0.15 - 3 s / 1.5 - 30 s / 7.5 - 150 s	
<b>Power supply circuit</b>		
Rated voltage $U_N$	A1, A2	24 V DC
Rated consumption	24 V DC	2.6 W
Operating voltage range $U_B$	0.85 - 1.1 x $U_N$	
Electrical isolation supply circuit - control circuit	no	
<b>Control circuit</b>		
Rated output voltage	S11, S33/S21	22 V DC
Input current / peak current	S12, S31/S22	25 mA / 100 mA
	S34, S35	40 mA / 50 mA
Response time $t_{A1} / t_{A2}$	30 ms / 700 ms	
Minimum ON time $t_M$	200 ms	
Recovery time $t_W$	500 ms	
Release time $t_R$	25 ms	
Release time $t_{R, \text{delayed contacts (tolerance)}}$	0.15 - 3 s / 1.5 - 30 s ( $\pm 16\%$ )	
Synchronous time $t_S$	500 ms	
Permissible test pulse time $t_{TP}$	< 1 ms	
Max. resistivity, per channel <sup>1)</sup>	$\leq (5 + (1.176 \times U_B / U_N - 1) \times 100) \Omega$	
<b>Output circuit</b>		
Enabling paths	13/14, 23/24	normally open contact
	37/38	normally open contact, OFF-delayed
Contact assignment	forcefully guided	
Contact type	Ag-alloy, gold-plated	
Rated switching voltage	enabling path	230 V AC
Max. thermal current $I_{th}$	enabling path	6 A
Max. total current $I^2$ of all current path ( $T_u = 55^\circ\text{C}$ )	5 A <sup>2</sup>	
Application category (NO)	AC-15	$U_e$ 230 V, $I_e$ 3 A
	DC-13	$U_e$ 24 V, $I_e$ 2 A
Short-circuit protection (NO), lead fuse / circuit breaker	6 A Class gG / melting integral < 100 A <sup>2</sup> s	
Mechanical life	10 <sup>7</sup> switching cycles	
<b>General data</b>		
Creepage distances and clearances between the circuits	EN 60664-1	
Protection degree according to EN 60529 (housing / terminals)	IP40 / IP20	
Ambient temperature / storage temperature	-25 °C - +55 °C / -25 °C - + 75 °C	
Wire ranges screw terminals,	fine-stranded / solid	1 x 0.2 mm <sup>2</sup> – 2.5 mm <sup>2</sup> / 2 x 0.2 mm <sup>2</sup> – 1.0 mm <sup>2</sup>
	fine-stranded with ferrules	1 x 0.25 mm <sup>2</sup> – 2.5 mm <sup>2</sup> / 2 x 0.25 mm <sup>2</sup> – 1.0 mm <sup>2</sup>
Permissible torque	0.5 - 0.6 Nm	
Wire ranges push-in terminals	1 x 0.25 mm <sup>2</sup> – 1.5 mm <sup>2</sup>	
Weight	0.20 kg	
Standards	EN ISO 13849-1, EN 62061, EN 50156-1	
Approvals	TÜV, GL, cULus, CCC	

<sup>1)</sup> If two-channel devices are installed as single channel, the value is halved.

# SNV 4063KP – Monitoring of emergency stop, safety gates and light barriers, ON-delayed



## Applications

- Protection of people and machinery
- Monitoring of emergency stop applications
- Monitoring of safety gates
- Monitoring of light barriers
- Monitoring of interlocking installation with position switches and integrated locking
- Control of spring-actuated interlocks
- Up to PL e/Category 4 (EN ISO 13849-1)
- Up to SIL<sub>CL</sub> 3 (EN 62061)

## Features

- Stop Category 0 according to EN 60204-1
- Single-channel or two-channel control
- Manual or automatic start
- ON-delay time adjustable in the range 0.15 to 3 s or 1.5 to 30 s
- Reset button monitoring, cross monitoring
- 3 enabling current paths (2 undelayed, 1 ON-delayed)

## Function

With supply voltage applied to terminals A1/A2, relays K3 and K4 (terminals 37/38) start with the pre-selected ON-delay time. The ON-delay time  $t_{A1}$  can be adjusted infinitely in the range 0.15 to 3 s or 1.5 to 30 s according to the device type. The device is enabled by pressing the reset button. The following operating modes can be selected:

• **Manual start** – The reset button must be connected to S34 through terminal S33. For starting the relay, the reset button must be pressed. Relays K3 and K4 (terminals 37/38) will switch into the OFF position. With the falling edge of the reset signal, the reset is completed and activates relays K1 and K2, which become self-locking after the response time  $t_{A3}$ . After this switch-on phase, the 2 enabling current paths defined for the output are closed (terminals 13/14, 23/24). With the emergency stop command, the power supply to relays K1 and K2 is interrupted. The enabling current paths (terminals 13/14, 23/24) are immediately opened with release time  $t_R$ , and relays K3 and K4 will start after the pre-set ON-delay time  $t_{A1}$ , terminals 37/38. Three LEDs display the state of relays K1/K2, K3/K4 and the supply voltage.

## Circuit diagram

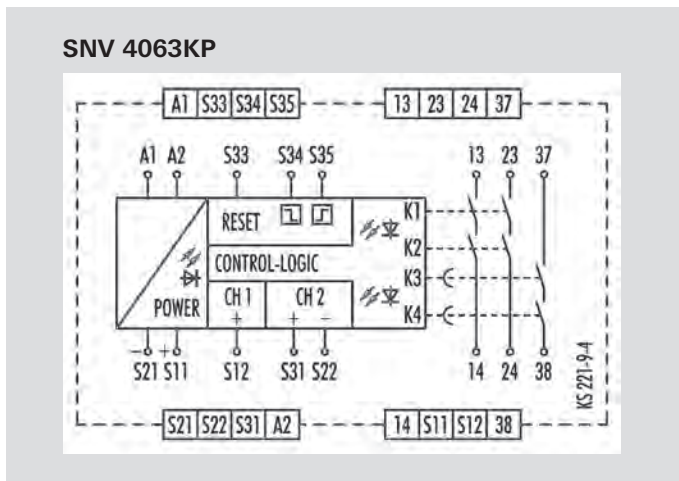

• **Automatic start** – For monitoring of interlocking installations with locking mechanism or safety gate applications in which on automatic start shall be performed it is necessary to jumper terminals S33/S35. The device will react at the rising edge of input S12 that is internally connected to S33. Relays K3 and K4 (terminals 37/38) will switch into the OFF position. With the rising edge of input S12 the relay K1 is activated and response time  $t_{A2}$  started. When the time has elapsed, the 2 enabling current paths are closed (terminals 13/14, 23/24). With a stop command the power supply to relays K1 and K2 is interrupted. The enabling current paths (terminals 13/14, 23/24) are immediately opened with release time  $t_R$ , and relays K3 and K4 will start after the pre-set ON-delay time  $t_{A1}$ , terminals 37/38.

## Overview of devices | part numbers

Type	Time range	Rated voltage	Terminals	Part no.	Std. pack
SNV 4063KP-A	3 s	24 V DC	Screw terminals, pluggable	R1.188.0660.0	1
	30 s	24 V DC	Screw terminals, pluggable	R1.188.0680.0	1

## Technical data

<b>Function</b>	Emergency stop relay for access delay combined with locking mechanism	
Function display	3 LEDs, green	
Function mode / adjustment	Time / stepless	
Adjustment range	0.15 - 3 s / 1.5 - 30 s	
<b>Power supply circuit</b>		
Rated voltage $U_N$	A1, A2	24 V DC
Rated consumption	24 V DC	2.6 W
Operating voltage range $U_B$	0.85 - 1.1 x $U_N$	
Electrical isolation supply circuit - control circuit	no	
<b>Control circuit</b>		
Rated output voltage	S11, S33/S21	22 V DC
Input current / peak current	S12, S31/S22	25 mA / 100 mA
	S34, S35	40 mA / 50 mA
Response time $t_{A1} / t_{A2}$	30 ms / 700 ms	
Minimum ON time $t_M$	200 ms	
Recovery time $t_W$	500 ms	
Release time $t_R$	25 ms	
Release time $t_{R, \text{delayed contacts (tolerance)}}$	0.15 - 3 s / 1.5 - 30 s ( $\pm 16\%$ )	
Synchronous time $t_S$	500 ms	
Permissible test pulse time $t_{TP}$	< 1 ms	
Max. resistivity, per channel <sup>1)</sup>	$\leq (5 + (1.176 \times U_B / U_N - 1) \times 100) \Omega$	
<b>Output circuit</b>		
Enabling paths	13/14, 23/24	normally open contact
	37/38	normally open contact, ON-delayed
Contact assignment	forceably guided	
Contact type	Ag-alloy, gold-plated	
Rated switching voltage	enabling path	230 V AC
Max. thermal current $I_{th}$	enabling path	6 A
Max. total current $I^2$ of all current path	( $T_u = 55^\circ\text{C}$ )	5 A <sup>2</sup>
Application category (NO)	AC-15	$U_e$ 230 V, $I_e$ 3 A
	DC-13	$U_e$ 24 V, $I_e$ 2 A
Short-circuit protection (NO), lead fuse / circuit breaker	6 A Class gG / melting integral < 100 A <sup>2</sup> s	
Mechanical life	10 <sup>7</sup> switching cycles	
<b>General data</b>		
Creepage distances and clearances between the circuits	EN 60664-1	
Protection degree according to EN 60529 (housing / terminals)	IP40 / IP20	
Ambient temperature / storage temperature	-25 °C - +55 °C / -25 °C - + 75 °C	
Wire ranges screw terminals,	fine-stranded / solid	1 x 0.2 mm <sup>2</sup> – 2.5 mm <sup>2</sup> / 2 x 0.2 mm <sup>2</sup> – 1.0 mm <sup>2</sup>
	fine-stranded with ferrules	1 x 0.25 mm <sup>2</sup> – 2.5 mm <sup>2</sup> / 2 x 0.25 mm <sup>2</sup> – 1.0 mm <sup>2</sup>
Permissible torque	0,5 - 0,6 Nm	
Wire ranges push-in terminals	1 x 0.25 mm <sup>2</sup> – 1.5 mm <sup>2</sup>	
Weight	0.20 kg	
Standards	EN ISO 13849-1, EN 62061, EN 50156-1	
Approvals	TÜV, GL, cULus, CCC	

<sup>1)</sup> If two-channel devices are installed as single channel, the value is halved.

# SNV 4074SL / SNV 4076SL – Monitoring of emergency stop, safety gates and light barriers, OFF-delayed



## Applications

- Controlled stop according to Category 1 (EN 60204-1)
- Monitoring of emergency stop applications
- Monitoring of safety gates
- Monitoring of interlocks
- Monitoring of light barriers
- Up to PL e/Category 4 (EN ISO 13849-1)
- Up to SIL<sub>CL</sub> 3 (EN 62061)

## Features

- Stop Category 0/1 according to EN 60204-1
- Time setting in 10 steps
- Time ranges 3s, 30s or 300s
- Single-channel or two-channel control
- Manual or automatic start
- SafeStart
- Cross monitoring

## OFF-delay function

After the supply voltage is applied to terminals A1/A2 and the safety inputs are closed, the enabling current paths (NO contacts) are closed automatically or by pressing the reset button (manual start). When the safety inputs are opened/de-energized the enabling current paths (NO contacts are opened immediately or with a delay).

- **Automatic start** – Reset input S14 is connected to safety input S12. To monitor external contact blocks (EDM), their NC contacts must be connected in series between S34 and S12.
- **Manual start without monitoring** – Reset input S14 is connected to safety input S12 via a reset button. To monitor external contact blocks (EDM), their NC contacts must be connected in series to the reset button.
- **Manual start with monitoring** – Reset input S34 is connected to safety input S11 via a reset button. To monitor external contact blocks (EDM), their NC contacts must be connected in series to the reset button.

## Circuit diagrams

SNV 4074SL

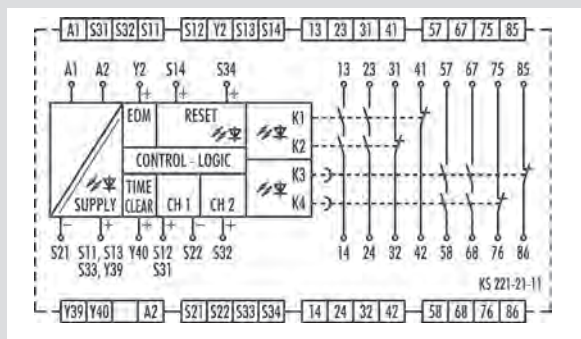

SNV 4076SL

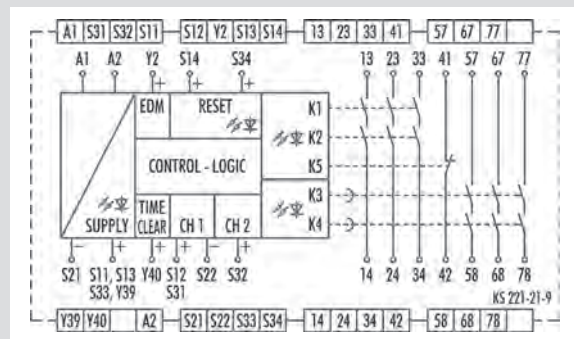

## Overview of devices | part numbers

Type	Time range	Rated voltage		Terminals	Part no.		Std. pack
					24V DC	115 – 230V AC	
SNV 4074SL-A	3s	24V DC	115 – 230V AC	Screw terminals, pluggable	R1.188.2130.0	R1.188.2310.0	1
SNV 4074SL-A	30s	24V DC	115 – 230V AC	Screw terminals, pluggable	R1.188.2160.0	R1.188.2340.0	1
SNV 4074SL-A	300s	24V DC	115 – 230V AC	Screw terminals, pluggable	R1.188.2190.0	R1.188.2370.0	1
SNV 4074SL-C	3s	24V DC	115 – 230V AC	Push-in terminals, pluggable	R1.188.2140.0	R1.188.2320.0	1
SNV 4074SL-C	30s	24V DC	115 – 230V AC	Push-in terminals, pluggable	R1.188.2170.0	R1.188.2350.0	1
SNV 4074SL-C	300s	24V DC	115 – 230V AC	Push-in terminals, pluggable	R1.188.2200.0	R1.188.2380.0	1
SNV 4076SL-A	3s	24V DC	115 – 230V AC	Screw terminals, pluggable	R1.188.2040.0	R1.188.2220.0	1
SNV 4076SL-A	30s	24V DC	115 – 230V AC	Screw terminals, pluggable	R1.188.2070.0	R1.188.2250.0	1
SNV 4076SL-A	300s	24V DC	115 – 230V AC	Screw terminals, pluggable	R1.188.2100.0	R1.188.2280.0	1
SNV 4076SL-C	3s	24V DC	115 – 230V AC	Push-in terminals, pluggable	R1.188.2050.0	R1.188.2230.0	1
SNV 4076SL-C	30s	24V DC	115 – 230V AC	Push-in terminals, pluggable	R1.188.2080.0	R1.188.2260.0	1
SNV 4076SL-C	300s	24V DC	115 – 230V AC	Push-in terminals, pluggable	R1.188.2110.0	R1.188.2290.0	1

## Technical data

<b>Function</b>	Emergency stop relay		
Function display	5 LEDs, green/red		
Function mode / adjustment	Time setting in 10 steps		
Adjustment range	0.1 - 3 s / 0 - 30 s / 0 - 300 s		
<b>Power supply circuit</b>			
Rated voltage $U_N$	A1, A2	24 V DC / 115-230 V AC	
Rated consumption	24 V DC   115-230 V AC	2.8 W   3.2 W / 6,3 VA	
Rated frequency	50 - 60 Hz		
Operating voltage range $U_B$	0.85 - 1.1 x $U_N$		
Electrical isolation supply circuit - control circuit	yes (at $U_N = AC 115-230 V$ )		
<b>Control circuit</b>			
Rated output voltage	S11, S13, S33, Y39 / S21	22 V DC	
Input current / peak current	S12, S31/S22, S32	3 mA / 4.5 mA	
	S14, S34, Y2, Y40	4 mA / 4.5 mA	
Response time $t_{A1} / t_{A2}$	200 ms		
Minimum ON time $t_M$	100 ms		
Recovery time $t_W$	50 ms		
Release time $t_R$	20 ms		
Release time $t^R$ , delayed contacts (tolerance)	0.1 / 0.2 / 0.3 / 0.4 / 0.5 / 0.8 / 1 / 1.5 / 2 / 3 s (0.1 % ± 15 ms) 0 / 2 / 4 / 6 / 0.5 / 8 / 10 / 15 / 20 / 30 s (0.1 % ± 15 ms) 0 / 20 / 40 / 60 / 80 / 100 / 150 / 200 / 250 / 300 s (0.1 % ± 15 ms)		
Permissible test pulse time $t_{TP}$	< 1 ms		
Max. resistivity, per channel <sup>1)</sup>	24 V DC   115-230 V AC	< 50 Ω   < 50 Ω	
<b>Output circuit</b>			
Enabling paths	13/14, 23/24, 33/34	normally open contact	
	57/58, 57/68, 77/78	normally open contact, OFF-delayed	
Signaling paths	31/32, 41/42   75/76, 85/86	normally closed contact   normally closed contact, OFF-delayed	
Contact assignment	forcefully guided		
Contact type	Ag-alloy, gold-plated		
Rated switching voltage	enabling- / signaling path	230 V AC	
Max. thermal current $I_{th}$	enabling- / signaling path	6 A / 2 A	
Max. total current $I^2$ of all current path ( $T_u = 55^\circ C$ )	40 A <sup>2</sup>		
Application category (NO)	AC-15   DC-13	$U_o$ 230 V, $I_o$ 3 A   $U_o$ 24 V, $I_o$ 3 A	
Short-circuit protection (NO), lead fuse / circuit breaker	6 A class gG / melting integral < 100 A <sup>2</sup> s		
Mechanical life	10 <sup>7</sup> switching cycles		
<b>General data</b>			
Creepage distances and clearances between the circuits	EN 60664-1		
Protection degree according to EN 60529 (housing / terminals)	IP40 / IP20		
Ambient temperature / storage temperature	-25 °C - +55 °C / -25 °C - +75 °C		
Wire ranges screw terminals,	fine-stranded / solid	1 x 0.2 mm <sup>2</sup> – 2.5 mm <sup>2</sup> / 2 x 0.2 mm <sup>2</sup> – 1.0 mm <sup>2</sup>	
	fine-stranded with ferrules	1 x 0.25 mm <sup>2</sup> – 2.5 mm <sup>2</sup> / 2 x 0.25 mm <sup>2</sup> – 1.0 mm <sup>2</sup>	
Permissible torque	0.5 - 0.6 Nm		
Wire ranges push-in terminals	1 x 0.25 mm <sup>2</sup> – 1.5 mm <sup>2</sup>		
Weight	0.33 kg / 0.35 kg		
Standards	EN ISO 13849-1, EN 62061, EN 50156-1		
Approvals	TÜV, cULus, CCC		

<sup>1)</sup> If two-channel devices are installed as single channel, the value is halved.

# SNV 4274SL / SNV 4074ST – Monitoring of emergency stop, light barriers and safety gates, OFF-delayed/ON-delayed



## Applications

- Monitoring of limit values in the process industry
- Monitoring of emergency stop applications
- Monitoring of safety gates
- Monitoring of interlocks
- Monitoring of light barriers
- Up to PL e/Category 4 (EN ISO 13849-1)
- Up to SIL<sub>CL</sub> 3 (EN 62061)

## Features

- Continuously adjustable, analog time setting
- Time ranges 3s, 30s or 300s
- Retriggering of the time delay possible
- Single-channel or two-channel control
- Manual or automatic start
- SafeStart
- Cross monitoring

## OFF-delay with retriggering function (SNV 4274SL)

After the supply voltage is applied to terminals A1/A2 and the safety inputs are closed, the contacts are switched on immediately, either automatically or by pressing the reset button (manual start). When the safety inputs are opened/de-energized, the contacts are switched off immediately or with a release delay.

The set release delay only expires if the safety inputs are opened longer than the release delay set on the device. If the safety inputs are closed again before the release delay has expired (retriggering), the delayed contacts will remain closed, too.

## ON-delay function (SNV 4074ST)

After the supply voltage is applied to terminals A1/A2 and the safety inputs are closed, the contacts are switched on immediately or with a response delay, either automatically or by pressing the reset button (manual start). When the safety inputs are opened/de-energized the contacts are switched off immediately.

## Circuit diagrams

SNV 4274SL

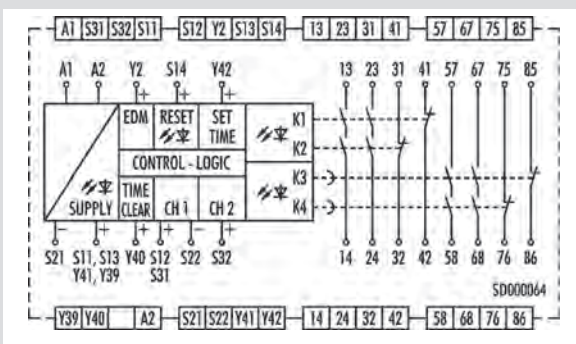

SNV 4074ST

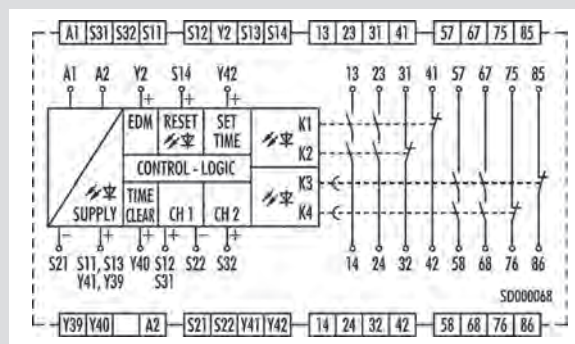

Overview of devices | Part numbers

Type	Time range	Rated voltage		Terminals	Part no.		Std. pack
					24V DC	115 – 230V AC	
SNV 4274SL-A	3s	24V DC	115 – 230V AC	Screw terminals, pluggable	R1.188.2470.0	R1.188.2650.0	1
SNV 4274SL-A	30s	24V DC	115 – 230V AC	Screw terminals, pluggable	R1.188.2500.0	R1.188.2680.0	1
SNV 4274SL-A	300s	24V DC	115 – 230V AC	Screw terminals, pluggable	R1.188.2530.0	R1.188.2710.0	1
SNV 4274SL-C	3s	24V DC	115 – 230V AC	Push-in terminals, pluggable	R1.188.2480.0	R1.188.2660.0	1
SNV 4274SL-C	30s	24V DC	115 – 230V AC	Push-in terminals, pluggable	R1.188.2510.0	R1.188.2690.0	1
SNV 4274SL-C	300s	24V DC	115 – 230V AC	Push-in terminals, pluggable	R1.188.2540.0	R1.188.2720.0	1
SNV 4074ST-A	3s	24V DC	115 – 230V AC	Screw terminals, pluggable	R1.188.2560.0	R1.188.2740.0	1
SNV 4074ST-A	30s	24V DC	115 – 230V AC	Screw terminals, pluggable	R1.188.2590.0	R1.188.2770.0	1
SNV 4074ST-A	300s	24V DC	115 – 230V AC	Screw terminals, pluggable	R1.188.2620.0	R1.188.2800.0	1
SNV 4074ST-C	3s	24V DC	115 – 230V AC	Push-in terminals, pluggable	R1.188.2570.0	R1.188.2750.0	1
SNV 4074ST-C	30s	24V DC	115 – 230V AC	Push-in terminals, pluggable	R1.188.2600.0	R1.188.2780.0	1
SNV 4074ST-C	300s	24V DC	115 – 230V AC	Push-in terminals, pluggable	R1.188.2630.0	R1.188.2810.0	1

Technical data

<b>Function</b>	Emergency stop relay		
Function display	5 LEDs, green/red		
Function mode / adjustment	Time / stepless		
Adjustment range	0.15 - 3 s / 1.5 - 30 s / 15 - 300 s		
<b>Power supply circuit</b>			
Rated voltage $U_N$	A1, A2	24 V DC / 115-230 V AC	
Rated consumption	24 V DC   115-230 V AC	2.8 W   3.2 W / 6.3 VA	
Rated frequency	50 - 60 Hz		
Operating voltage range $U_B$	0.85 - 1.1 x $U_N$		
Electrical isolation supply circuit - control circuit	yes (at $U_N = 115-230 V AC$ )		
<b>Control circuit</b>			
Rated output voltage	S11, S13, S33, Y39 / S21	22 V DC	
Input current / peak current	S12, S31/S22, S32	3 mA / 4,5 mA	
	S14, S34, Y2, Y40	4 mA / 4,5 mA	
Response time $t_{A1} / t_{A2}$	200 ms		
Minimum ON time $t_M$	100 ms		
Recovery time $t_W$	50 ms		
Release time $t_R$	20 ms		
Release time $t_{R, delayed contacts (tolerance)}$	0,15 - 3 s ( $\pm 16\%$ of the setting value)		
	1,5 - 30 s ( $\pm 16\%$ of the setting value)		
	15 - 300 s ( $\pm 16\%$ of the setting value)		
Permissible test pulse time $t_{TP}$	< 1 ms		
Max. resistivity, per channel <sup>1)</sup>	24 V DC   115-230 V AC	< 50 $\Omega$   < 50 $\Omega$	
<b>Output circuit</b>			
Enabling paths	13/14, 23/24	normally open contact	
	57/58, 57/68	normally open contact, time delayed	
Signaling paths	31/32, 41/42   75/76, 85/86	normally closed contact   normally closed contact, time delayed	
Contact assignment	forcibly guided		
Contact type	Ag-alloy, gold-plated		
Rated switching voltage	enabling- / signaling path	230 V AC	
Max. thermal current $I_{th}$	enabling- / signaling path	6 A / 2 A	
Max. total current $I^2$ of all current path	( $T_u = 55\text{ }^\circ\text{C}$ )	40 A <sup>2</sup>	
Application category (NO)	AC-15   DC-13	$U_o$ 230 V, $I_o$ 3 A   $U_o$ 24 V, $I_o$ 3 A	
Short-circuit protection (NO), lead fuse / circuit breaker	6 A class gG / melting integral < 100 A <sup>2</sup> s		
Mechanical life	10 <sup>7</sup> switching cycles		
<b>General data</b>			
Creepage distances and clearances between the circuits	EN 60664-1		
Protection degree according to EN 60529 (housing / terminals)	IP40 / IP20		
Ambient temperature / storage temperature	-25 $^\circ\text{C}$ - +55 $^\circ\text{C}$ / -25 $^\circ\text{C}$ - + 75 $^\circ\text{C}$		
Wire ranges screw terminals,	fine-stranded / solid	1 x 0.2 mm <sup>2</sup> – 2.5 mm <sup>2</sup> / 2 x 0.2 mm <sup>2</sup> – 1.0 mm <sup>2</sup>	
	fine-stranded with ferrules	1 x 0.25 mm <sup>2</sup> – 2.5 mm <sup>2</sup> / 2 x 0.25 mm <sup>2</sup> – 1.0 mm <sup>2</sup>	
Permissible torque	0.5 - 0.6 Nm		
Wire ranges push-in terminals	1 x 0.25 mm <sup>2</sup> – 1.5 mm <sup>2</sup>		
Weight	0,33 kg / 0,35 kg		
Standards	EN ISO 13849-1, EN 62061, EN 50156-1		
Approvals	TÜV, cULus, CCC		

<sup>1)</sup> If two-channel devices are installed as single channel, the value is halved.

# SNE 1 Contact expansion



## Applications

- Duplication of the enabling current paths of a basic device
- Contact expansion in safety-oriented systems
- Up to PL e/Category 4 (EN ISO 13849-1)\*
- Up to SIL<sub>CL</sub> 3 (EN 62061)\*

## Features

- Stop Category 0 and 1 according to EN 60204-1
- Single-channel operation
- 2 changeover contacts (positively driven)
- Sturdy retaining bracket

\* Depends on the category of the basic device or the safety control.

## Circuit diagram

### SNE 1

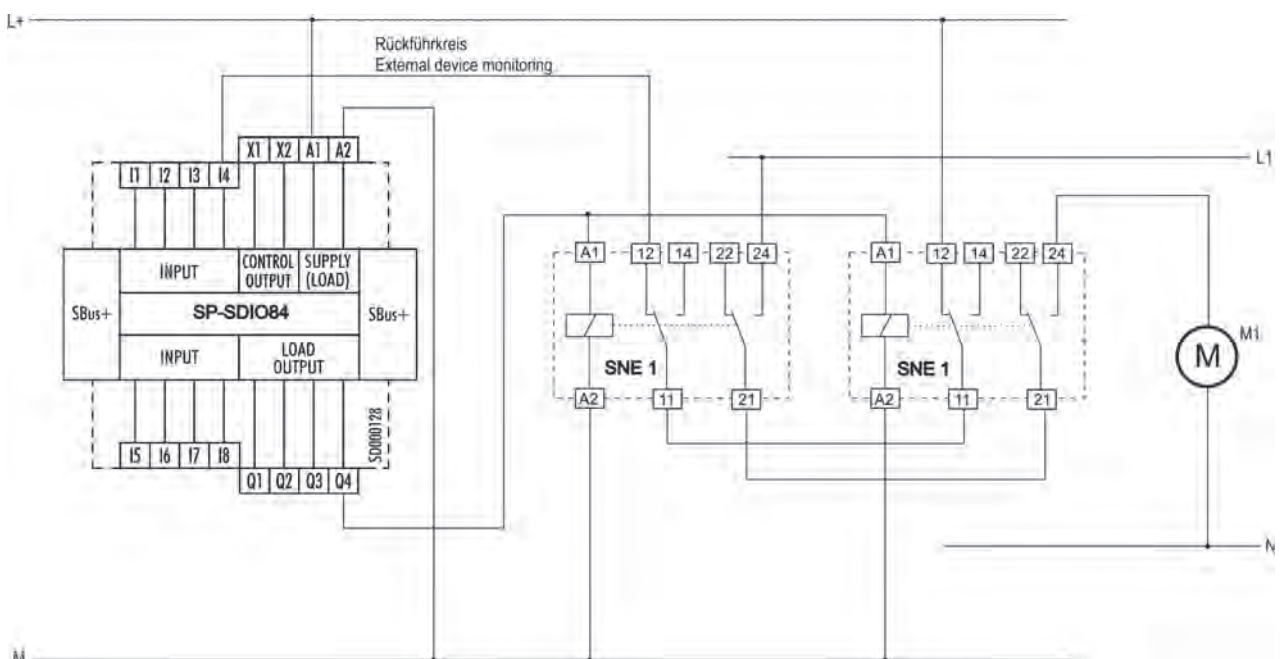

## Overview of devices | Part numbers

Type	Rated voltage	Terminals	Part no.	Std. Pack
SNE 1	24 V DC	Screw terminals	R1.188.3950.0	1

## Circuit diagram

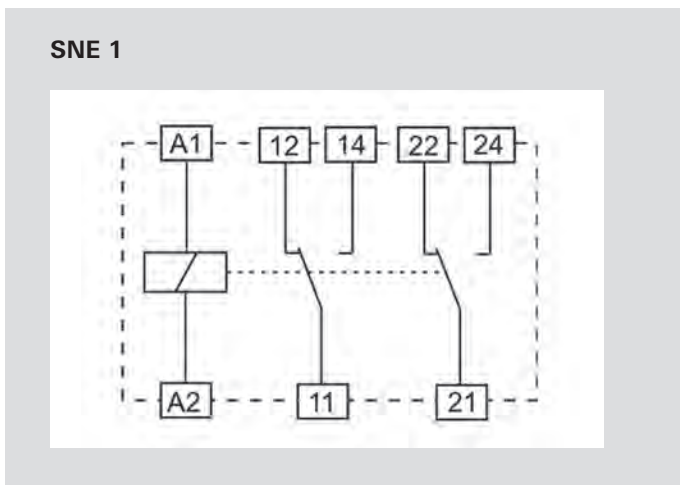

## Technical data

<b>Function</b>	Emergency stop expansion relay	
Function display	none	
<b>Power supply circuit</b>		
Rated voltage $U_N$	A1/A2	24 V DC
Rated consumption	0.7 W	
Operating voltage range $U_B$	0.63 - 1.25 x $U_N$	
Electrical isolation supply circuit - control circuit	yes	
<b>Control circuit</b>		
Input current / peak current	A1/A2	ca. 29 mA
Response time $t_{A1} / t_{A2}$	12 ms	
Release time $t_R$	< 20 ms	
<b>Output circuit</b>		
Enabling paths	11/12/14, 21/22/24	changeover contact
Contact assignment	forceably guided	
Contact type	Ag-alloy	
Rated switching voltage	230 V AC, 24 V DC	
Max. thermal current $I_{th}$	8 A	
Max. total current $I^2$ of all current path ( $T_u = 55\text{ °C}$ )	72 A <sup>2</sup>	
Application category (NO)	AC-15	$U_o$ 230 V, $I_o$ 2 A
	DC-13	$U_o$ 24 V, $I_o$ 3 A
Short-circuit protection (NO), lead fuse / circuit breaker	6 A class gL / melting integral < 100 A <sup>2</sup> s	
Mechanical life	10 x 10 <sup>6</sup> switching cycles	
<b>General data</b>		
Creepage distances and clearances between the circuits	EN 61810-5	
Protection degree according to EN 60529 (housing / terminals)	IP20 / IP20	
Ambient temperature / storage temperature	-40 °C - +70 °C / -40 °C - + 70	
Wire range	fine-stranded / solid	0.25 mm <sup>2</sup> – 4.0 mm <sup>2</sup> (AWG 24-12) / 0.25 – 6.0 mm <sup>2</sup> (AWG 24-10)
Permissible torque	0.5 Nm	
Weight	0.06 kg	
Standards	EN 50205 (Type B)	
Approvals	cURus	

# SNE 4003K Contact expansion



## Function

The SNE 4003K is an expansion device for basic devices (such as safety switching devices, light curtains, laser scanners) that are part of the machine's safety equipment and are used for protecting people, materials and machines.

The device is designed with two channels and redundancy. The enabling current paths are separated from the control circuits and signaling circuits with creepage distances and clearances > 5.5 mm (safe isolation). There is basic insulation to separate the enabling current paths from one another and the control circuits from the signaling current paths. The broad input voltage range of 15 V DC to 30 V DC makes the SNE 4003K ideal for single-channel or two-channel control by semiconductors.

## Circuit diagram

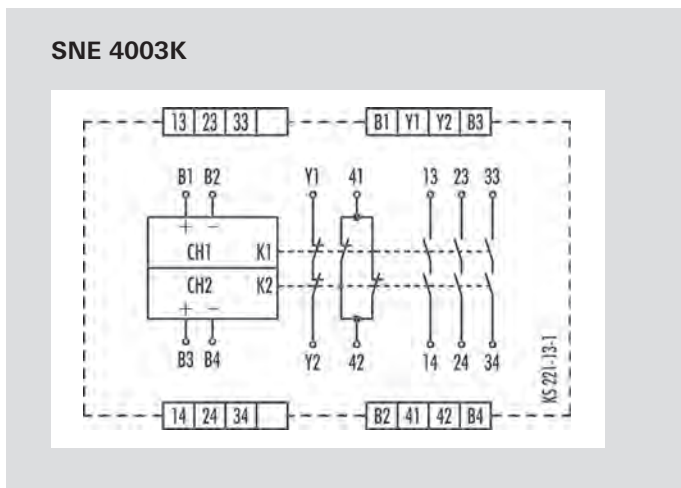

## Applications

- Duplication of the enabling current paths of a basic device
- Contact expansion in safety-oriented systems
- Contact expansion for light curtains
- Up to PL e/Category 4 (EN ISO 13849-1)\*
- Up to SIL<sub>CL</sub> 3 (EN 62061)\*

## Features

- Safe isolation according to EN 50178
- Single-channel or two-channel operation
- 3 enabling current paths (NO contact)
- 2 signaling current paths (NC contact)
- Wide input voltage range from 15 to 30 V DC
- Suitable for semiconductor outputs

\* Depends on the category of the basic device or the safety control.

Input voltage to the SNE 4003K is connected via one or two enabling current paths of a basic device. When the input voltage is applied relays K1 and K2 switch into the ON position. After this switch-on phase, enabling current paths 13/14, 23/24, 33/34 are closed and feedback current path Y1/Y2 and signaling current path 41/42 are opened.

This is displayed through two LEDs, K1 and K2, which are assigned to relays K1 and K2. If the enabling current paths of the basic device are opened when the emergency stop button is pressed, relays K1 and K2 on the SNE 4003K switch back into the OFF-position. The enabling current paths open and the feedback current path closes. Feedback current path Y1/Y2 prevents the basic device from switching on again before K1 or K2 releases.

## Overview of devices | Part numbers

Type	Rated voltage	Terminals	Part no.	Std. Pack
SNE 4003K-A	24 V DC	Screw terminals, pluggable	R1.188.1340.0	1

## Technical data

<b>Function</b>	Emergency stop expansion relay	
Function display	2 LEDs, green	
<b>Power supply circuit</b>		
Rated voltage $U_N$	B1/B2, B3/B4	24 V DC
Rated consumption	24 V DC	1.2 W
Operating voltage range $U_B$	0.63 - 1.25 x $U_N$	
Electrical isolation supply circuit - control circuit	no	
<b>Control circuit</b>		
Input current / peak current	B1/B2, B3/B4	50 mA / 500 mA
Response time $t_{A1}$ / $t_{A2}$	< 40 ms	
Recovery time $t_W$	≤ 40 ms	
Release time $t_R$	< 20 ms	
Permissible test pulse time $t_{TP}$	< 1 ms	
Max. resistivity, per channel <sup>1)</sup>	≤ (5 + (1.6 x $U_B$ / $U_N$ - 1) x 100) Ω	
<b>Output circuit</b>		
Enabling paths	13/14, 23/24, 33/34	normally open contact
Signaling paths	41/42	normally closed contact
Contact assignment	forcebly guided	
Contact type	Ag-alloy, gold-plated	
Rated switching voltage	enabling- / signaling path	230 V AC
	Y1/Y2	230 V AC
Max. thermal current $I_{th}$	enabling- / signaling path	6 A / 2 A
	Y1/Y2	2 A
Max. total current $I^2$ of all current path	( $T_u = 55$ °C)	9 A <sup>2</sup>
Application category (NO)	AC-15	$U_o$ 230 V, $I_o$ 3 A
	DC-13	$U_o$ 24 V, $I_o$ 2,5 A
Short-circuit protection (NO), lead fuse / circuit breaker	6 A class gG / melting integral < 100 A <sup>2</sup> s	
Mechanical life	10 <sup>7</sup> switching cycles	
<b>General data</b>		
Creepage distances and clearances between the circuits	EN 60664-1	
Protection degree according to EN 60529 (housing / terminals)	IP40 / IP20	
Ambient temperature / storage temperature	-25 °C - +55 °C / -25 °C - + 75 °C	
Wire ranges screw terminals,	fine-stranded / solid	1 x 0.2 mm <sup>2</sup> - 2.5 mm <sup>2</sup> / 2 x 0.2 mm <sup>2</sup> - 1.0 mm <sup>2</sup>
	fine-stranded with ferrules	1 x 0.25 mm <sup>2</sup> - 2.5 mm <sup>2</sup> / 2 x 0.25 mm <sup>2</sup> - 1.0 mm <sup>2</sup>
Permissible torque	0.5 - 0.6 Nm	
Wire ranges push-in terminals	1 x 0.25 mm <sup>2</sup> - 1.5 mm <sup>2</sup>	
Weight	0,21 kg	
Standards	EN ISO 13849-1, EN 62061	
Approvals	DGUV, cULus, CCC	

<sup>1)</sup> If two-channel devices are installed as single channel, the value is halved.

# SNE 4004K/KV Contact expansion



## Function

### SNE 4004K

Supply voltage to the SNE devices is routed via an enabling current path of a basic device. When the supply voltage is applied relays K1 and K2 switch into the ON position. After this switch-on phase the four enabling current paths 13/14, 23/24, 33/34, 43/44 (of the SNE 4004K) or 17/18, 27/28, 37/38, 47/48 (of the SNE 4004KV) are closed and the feedback current path Y1/Y2 is open. This is displayed through two LEDs that are assigned to relays K1 and K2.

When the enabling current paths of the basic device are opened through the operation of the emergency stop button, relays K1 and K2 on the SNE 4004K switch back into the OFF-position. The enabling current paths open and the feedback current path closes. Feedback current path Y1/Y2 prevents the basic device from switching on again before K1 or K2 releases.

## Circuit diagrams

SNE 4004K

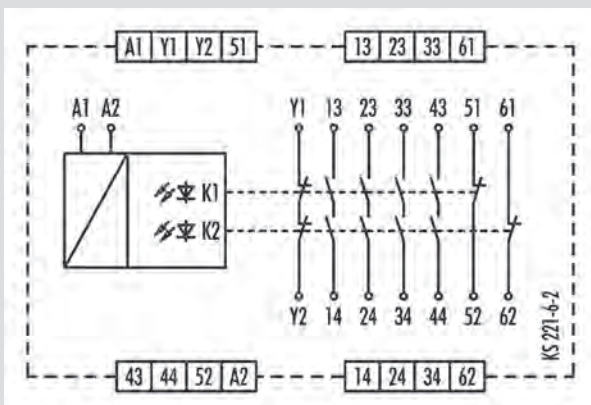

SNE 4004KV

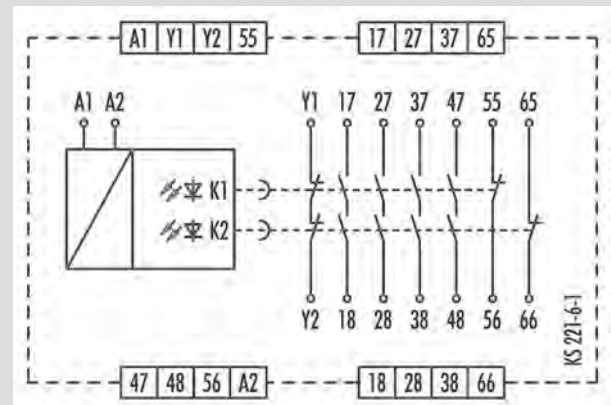

## Applications

- Expansion of a basic device's enabling current paths
- Contact expansion in safety equipment
- Up to PL d/Category 3 (EN ISO 13849-1)\*
- Up to SIL<sub>CL</sub> 2 (EN 62061)\*

## Features

- Stop Category 0 and 1 according to EN 60204-1 (see "Function")
- Single-channel or two-channel control
- SNE 4004K: 4 enabling current paths, undelayed (NO contact)  
3 signaling current paths, undelayed (NC contact)
- SNE 4004KV: 4 enabling current paths, OFF-delayed (NO contact)  
3 signaling current paths, OFF-delayed (NC contact),  
Time buffering

\* Depends on the category of the basic device or the safety control.

### SNE 4004KV

The functions of this device correspond to those of the SNE 4004K. The SNE 4004KV is available with the following four OFF-delay times  $t_{R1}$ : 0.5 s; 1 s; 2 s and 3 s. The device has an OFF-delay time that is enabled through capacitors.

This causes the OFF-delay time  $t_{R1}$  to elapse completely even in case of failure of the power supply (A1/A2). It cannot be reset before it has elapsed. Once the delay time has elapsed, relays K1 and K2 switch into the OFF- position. OFF-delay times of > 0 s correspond to stop category 1.

## Overview of devices | part numbers

Type	Time range	Rated voltage	Terminals	Part no.	Std. Pack
SNE 4004K-A	–	24 V AC/DC	Screw terminals, pluggable	R1.188.0590.0	1
SNE 4004K-C	–	24 V AC/DC	Push-in terminals, pluggable	R1.188.1980.0	1
SNE 4004KV-A	0.5 s	24 V DC	Screw terminals, pluggable	R1.188.0460.0	1
	1 s	24 V DC	Screw terminals, pluggable	R1.188.0470.0	1
	2 s	24 V DC	Screw terminals, pluggable	R1.188.0480.0	1
	3 s	24 V DC	Screw terminals, pluggable	R1.188.0490.0	1
SNE 4004KV-C	0.5 s	24 V DC	Push-in terminals, pluggable	R1.188.2410.0	1
	1 s	24 V DC	Push-in terminals, pluggable	R1.188.2420.0	1
	2 s	24 V DC	Push-in terminals, pluggable	R1.188.2430.0	1
	3 s	24 V DC	Push-in terminals, pluggable	R1.188.2440.0	1

## Technical data

<b>Function</b>	Emergency stop expansion relay	
Function display	2 LEDs, green	
Function mode / adjustment	Time, fixed	
Adjustment range	0,5 s / 1 s / 2 s / 3 s	
<b>Power supply circuit</b>		
Rated voltage $U_N$	A1, A2	24 V DC / 24 V AC/DC
Rated consumption	24 V DC   24 V AC/DC	1.2 W   1.7 W / 3.1 VA
Rated frequency	50 - 60 Hz	
Operating voltage range $U_B$	0.85 - 1.1 x $U_N$	
Electrical isolation supply circuit - control circuit	non	
<b>Control circuit</b>		
Input current / peak current	A1, A2	65 mA / 1800 mA
Response time $t_{A1}$ / $t_{A2}$	20 ms	
Minimum ON time $t_M$	0,15 x $t_R$	
Recovery time $t_W$	≤ 200 ms	
Release time $t_R$	40 ms	
Release time $t_R$ , delayed contacts (tolerance)	0.5 s / 1 s / 2 s / 3 s (± 35 %)	
Max. resistivity, per channel <sup>1)</sup>	≤ (2.5 + (1.176 x $U_B$ / $U_N$ - 1) x 50) Ω	
<b>Output circuit</b>		
Enabling paths	13/14, 23/24, 33/34, 43/44	normally open contact
	17/17, 27/28, 37/38, 47/48	normally open contact, time delayed
Signaling paths	51/52, 61/62	normally closed contact
	55/56, 65/66	normally closed contact, time delayed
Contact assignment	forceably guided	
Contact type	Ag-alloy, gold-plated	
Rated switching voltage	enabling / signaling path	230 V AC
	Y1/Y2	230 V AC
Max. thermal current $I_{th}$	enabling / signaling path	6 A / 2 A
	Y1/Y2	2 A
Max. total current $I^2$ of all current path ( $T_u = 55$ °C)	9 A <sup>2</sup>	
Application category (NO)	AC-15   DC-13	$U_o$ 230 V, $I_o$ 5 A   $U_o$ 24 V, $I_o$ 5 A
Short-circuit protection (NO), lead fuse / circuit breaker	6 A class gG / melting integral < 100 A <sup>2</sup> s	
Mechanical life	10 <sup>7</sup> switching cycles	
<b>General data</b>		
Creepage distances and clearances between the circuits	EN 60664-1	
Protection degree according to EN 60529 (housing / terminals)	IP40 / IP20	
Ambient temperature / storage temperature	-25 °C - +55 °C / -25 °C - + 75 °C	
Wire ranges screw terminals,	fine-stranded / solid	1 x 0.2 mm <sup>2</sup> – 2.5 mm <sup>2</sup> / 2 x 0.2 mm <sup>2</sup> – 1.0 mm <sup>2</sup>
	fine-stranded with ferrules	1 x 0.25 mm <sup>2</sup> – 2.5 mm <sup>2</sup> / 2 x 0.25 mm <sup>2</sup> – 1.0 mm <sup>2</sup>
Permissible torque	0,5 - 0,6 Nm	
Wire ranges push-in terminals	1 x 0.25 mm <sup>2</sup> – 1.5 mm <sup>2</sup>	
Weight	0.20 kg	
Standards	EN ISO 13849-1, EN 62061	
Approvals	DGUV, cULus, CCC	

<sup>1)</sup> If two-channel devices are installed as single channel, the value is halved.

# SNE 4012K / SNE 4024K Contact expansion



### Applications

- Expansion of a basic device's enabling current paths
- Contact expansion in safety equipment
- Up to PL e/Category 3 (EN ISO 13849-1)\*
- Up to SIL<sub>CL</sub> 3 (EN 62061)\*

### Features

- Stop Category 0 and 1 according to EN 60204-1 (see "Function")
- Single-channel control
- SNE 4012K: 2 enabling current paths (NO contact)
- SNE 4024K: 2x2 enabling current paths (NO contact)

\* Depends on the category of the basic device or the safety control.



### Function

Once the supply voltage has been applied to terminals B1/A2 (B2/A2), the enabling current paths (NOC) are automatically closed and the signaling current paths (NCC) are opened.

When the supply voltage is ceased, the enabling current paths (NOC) are immediately opened and the signaling current paths (NCC) are immediately closed.

### Circuit diagrams

SNE 4012K

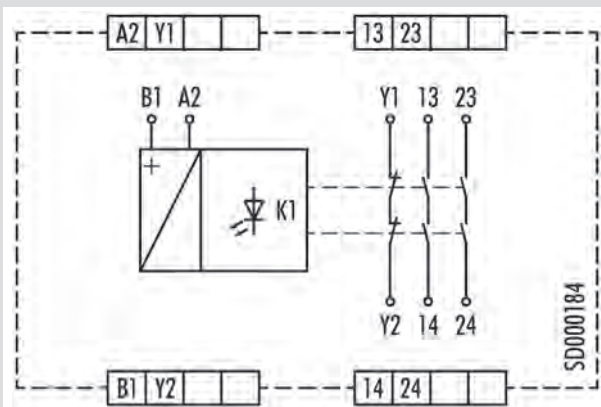

SNE 4024K

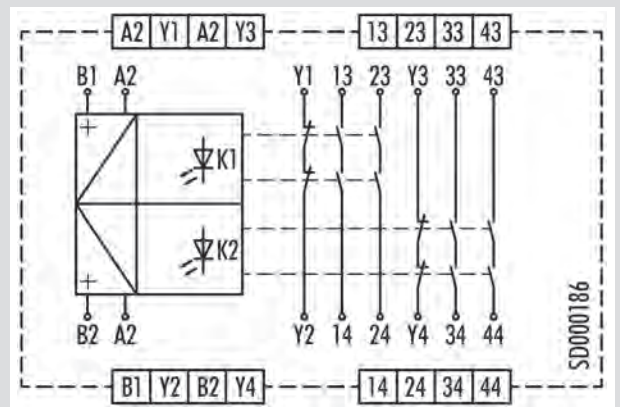

## Overview of devices | part numbers

Type	Rated voltage	Terminals	Part no.	Std. Pack
SNE 4012K-A	24 V DC	Screw terminals, pluggable	R1.188.3910.0	1
SNE 4012K-C	24 V DC	Push-in terminals, pluggable	R1.188.3920.0	1
SNE 4024K-A	24 V DC	Screw terminals, pluggable	R1.188.3930.0	1
SNE 4024K-C	24 V DC	Push-in terminals, pluggable	R1.188.3940.0	1

## Technical data

<b>Function</b>	Emergency stop expansion relay	
Function display – SNE 4012K	1 LED, green	
Function display – SNE 4024K	2 LED, green	
<b>Power supply circuit</b>		
Rated voltage $U_N$	B1/A2; B2/A2	24 V DC
Rated consumption – SNE 4012K	0.7 W	
Rated consumption – SNE 4022K	1.4 W	
Operating voltage range $U_B$	0.75 - 1.25 $U_N$	
<b>Control circuit</b>		
Input current / peak current	B1/A2	ca. 30 mA / 110 mA
	B2/A2	ca. 30 mA / 110 mA
Response time $t_{A1}$ / $t_{A2}$	< 15 ms	
Recovery time $t_W$	≤ 30 ms	
Release time $t_R$	≤ 15 ms	
Max. resistivity, per channel <sup>1)</sup>	≤ (5 + (1,333 x $U_B$ / $U_N$ - 1) x 200) Ω	
<b>Output circuit</b>		
Enabling paths	13/14, 23/24	normally open contact
	33/34, 43/44	normally open contact
Signaling paths	Y1/Y2	normally closed contact
	Y3/Y4	normally closed contact
Contact assignment	forcefully guided	
Contact type	Ag-alloy	
Rated switching voltage	230 V AC, 24 V DC	
Max. thermal current $I_{th}$	enabling / signaling path	6 A
Max. total current $I^2$ of all current path	– SNE 4012K ( $T_u = 55$ °C)	72 A <sup>2</sup>
Max. total current $I^2$ of all current path	– SNE 4024K ( $T_u = 55$ °C)	2 x 72 A <sup>2</sup> / 2 x 8 A <sup>2</sup>
Application category (NO)	AC-15   DC-13	$U_e$ 230 V, $I_e$ 3 A   $U_e$ 24 V, $I_e$ 1 A
Short-circuit protection (NO), lead fuse / circuit breaker	6 A class gL / melting integral < 100 A <sup>2</sup> s	
Mechanical life	10 x 10 <sup>6</sup> switching cycles	
<b>General data</b>		
Creepage distances and clearances between the circuits	EN 60664-1	
Protection degree according to EN 60529 (housing / terminals)	IP40 / IP20	
Ambient temperature / storage temperature	-25 °C - +65 °C / -25 °C - + 75 °C	
Wire ranges screw terminals,	fine-stranded / solid	1 x 0.2 mm <sup>2</sup> – 2.5 mm <sup>2</sup> / 2 x 0.2 mm <sup>2</sup> – 1.0 mm <sup>2</sup>
	fine-stranded with ferrules	1 x 0.25 mm <sup>2</sup> – 2.5 mm <sup>2</sup> / 2 x 0.25 mm <sup>2</sup> – 1.0 mm <sup>2</sup>
Permissible torque	0.5 - 0.6 Nm	
Wire ranges push-in terminals	1 x 0.25 mm <sup>2</sup> – 1.5 mm <sup>2</sup>	
Weight	0.180 kg	
Standards	EN ISO 13849-1, EN 62061, EN81-1, DIN EN 50156-1, EN 61511	
Approvals	TÜV, cULus, CCC	

<sup>1)</sup> If two-channel devices are installed as single channel, the value is halved.

# SNE 4028S

## Contact expansion



### Applications

- Duplication of the enabling current paths of a basic device
- Contact expansion in safety-oriented systems
- Amplification of the output performance of light curtains
- Up to PL e/Category 4 (EN ISO 13849-1)\*
- Up to SIL<sub>CL</sub> 3 (EN 62061)\*

### Features

- Single-channel or two-channel control
- Cross monitoring
- Safe isolation
- 8 enabling current paths, 1 signal current path

\* Depends on the category of the basic device or the safety control.

### Function

After the supply voltage is applied to terminals A1/ A2 and the safety inputs are closed, the enabling current paths (NO contacts) are closed and the signaling current paths (NC contacts) are opened automatically. When the safety inputs are opened/de-energized the enabling current paths (NO contacts) are opened immediately and the signaling current paths (NC contacts) are closed.

### Circuit diagram

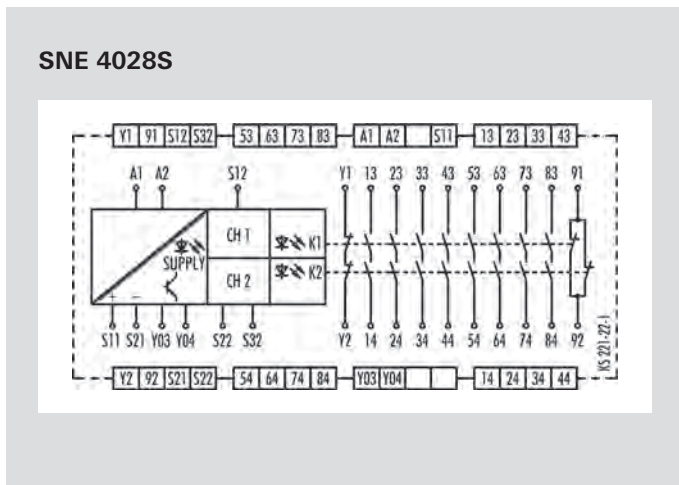

## Overview of devices | part numbers

Type	Rated voltage	Terminals	Part no.	Std. pack
SNE 4028S-A	24 V DC	Screw terminals, pluggable	R1.188.3120.0	1
SNE 4028S-A	115-230 V AC	Screw terminals, pluggable	R1.188.3510.0	1
SNE 4028S-C	24 V DC	Push-in terminals, pluggable	R1.188.3540.0	1
SNE 4028S-C	115-230 V AC	Push-in terminals, pluggable	R1.188.3550.0	1

## Technical data

<b>Function</b>	Contact expansion relay	
Function display	3 LEDs, green	
<b>Power supply circuit</b>		
Rated voltage $U_N$	A1, A2	24 V AC/DC / 115-230 V AC
Rated consumption	24 V AC/DC	3.4 W / 6.1 VA
	115-230 V AC	2.7 W / 6 VA
Rated frequency	50 - 60 Hz	
Operating voltage range $U_B$	0.85 - 1.1 x $U_N$	
Electrical isolation supply circuit - control circuit	yes (at $U_N = 115-230$ V AC)	
<b>Control circuit</b>		
Rated output voltage	S11/S21	24 V DC
Input current / peak current	S12, S32/S22	50 mA / 200 mA
Response time $t_{A1} / t_{A2}$	25 ms	
Recovery time $t_w$	≤ 40 ms	
Release time $t_R$	10 ms	
Permissible test pulse time $t_{TP}$	< 1 ms	
Max. resistivity, per channel <sup>1)</sup>	24 V AC/DC	≤ (5 + (1.176 x $U_B / U_N - 1) x 100) \Omega$
	115-230 V AC	≤ 12 $\Omega$
<b>Output circuit</b>		
Enabling paths	13/14, 23/24, 33/34, 43/44	normally open contact
	53/54, 63/64, 73/74, 83/84	normally open contact
Signaling paths	91/92, Y1/Y2	normally closed contact
	Y03/Y04	semiconductor output (PNP), not safety-oriented
Contact assignment	forcefully guided	
Contact type	Ag-alloy, gold-plated	
Rated switching voltage	enabling- / signaling path	230 V AC / 24 V DC
	Y03/Y04	24 V DC
Max. thermal current $I_{th}$	enabling- / signaling path	6 A / 2 A
	Y03/Y04	20 mA
Max. total current $I_2$ of all current path ( $T_u = 55$ °C)	2 x 25 A <sup>2</sup>	
Application category (NO)	AC-15	$U_o$ 230 V, $I_o$ 5 A
	DC-13	$U_o$ 24 V, $I_o$ 5 A
Short-circuit protection (NO), lead fuse / circuit breaker	6 A class gG / melting integral < 90 A <sup>2</sup> s	
Mechanical life	10 <sup>7</sup> switching cycles	
<b>General data</b>		
Creepage distances and clearances between the circuits	EN 60664-1	
Protection degree according to EN 60529 (housing / terminals)	IP40 / IP20	
Ambient temperature / storage temperature	-25 °C - +55 °C / -25 °C - + 75 °C	
Wire ranges screw terminals,	fine-stranded / solid	1 x 0.2 mm <sup>2</sup> – 2.5 mm <sup>2</sup> / 2 x 0.2 mm <sup>2</sup> – 1.0 mm <sup>2</sup>
	fine-stranded with ferrules	1 x 0.25 mm <sup>2</sup> – 2.5 mm <sup>2</sup> / 2 x 0.25 mm <sup>2</sup> – 1.0 mm <sup>2</sup>
Permissible torque	0.5 - 0,6 Nm	
Wire ranges push-in terminals	1 x 0.25 mm <sup>2</sup> – 1.5 mm <sup>2</sup>	
Weight	0.38 kg	
Standards	EN ISO 13849-1, EN 62061, EN 61511	
Approvals	DGUV, cULus, CCC	

<sup>1)</sup> If two-channel devices are installed as single channel, the value is halved.



## sensor PRO — safe signal acquisition

### Safety light curtains SLC Series

**SLC series** safety light curtains are ideally suited for implementing optoelectronic protective devices. The **SLC series** is thereby used to protect operators from dangerous areas or as an access control against unauthorized trespassing.

### Safety light grids SLD Series

The **SLD series** safety light grids are optoelectronic personal protective devices for access protection to hazardous areas on machinery and equipment.

The two product families, **SLC** and **SLD**, offer an extensive range of items, uncomplicated connection technology and comprehensive additional functions for simple commissioning and fast diagnosis.



Light curtains + light grids  
**SLC + SLD Series**

Emergency stop buttons  
**SNH Series**



## Emergency stop buttons SNH Series

The emergency stop buttons of the **SNH series** provide for the safety of man and machine and offer users a practical, robust and reliable design.

The fast and easy installation of the emergency stop buttons saves time and money, and a long durability as well as reliable functionality is guaranteed through the use of high-quality materials.

The emergency stop buttons of the **SNH series** can be used in a wide range of applications across the various sectors.

## Safety switch with guard locking SIN Series

The safety switches in the **SIN series** are used to monitor the position of movable guards and prevent the accidental opening of safety doors or flaps with their integrated guard locking. They are typically used on machines with movements that occur after switching off, where it must be ensured that no person may gain access until the hazardous situation has ended.

## Safety switch with separated actuator SMS Series

Safety switches in the **SMS series** are used to monitor movable guards. The safety switches are suitable for the protection of people and processes and are available in three different designs.

## Non-contact safety switches STS Series

The non-contact safety switches from the **STS series** feature maximum manipulation protection and are used for monitoring the position of machine parts and the position of doors and switches of isolating protective devices.

## Magnetic safety switches SMA Series

The sensors of the **SMA series** are magnetic safety sensors which are used for the contactless monitoring of protective doors and the detection of safe positions. In addition, they are equipped with integrated manipulation protection and can be used up to IP67.

Mechanical safety switches

**SIN + SMS Series**



Non-contact safety switches

**STS + SMA Series**

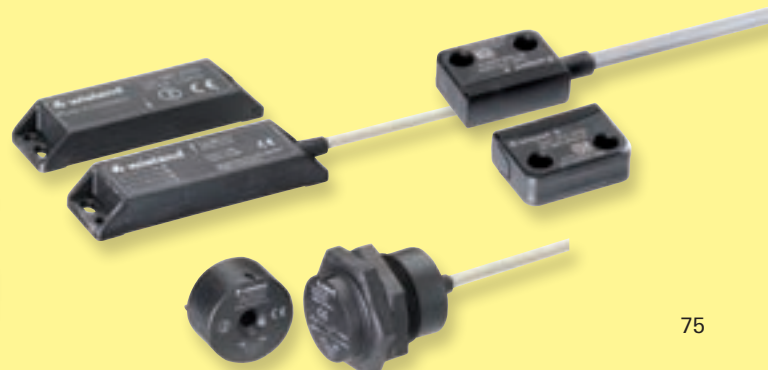

# SLC – safety light curtain

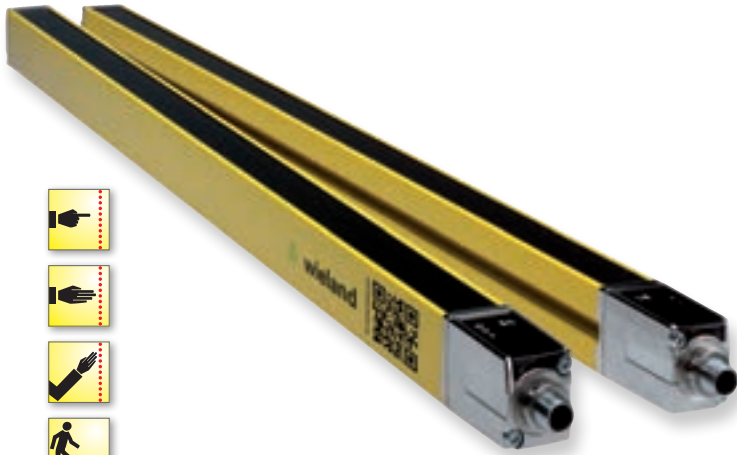

### Applications

- Access protection (finger, hand and arm protection)
- Access security (personal protection)
- Horizontal zone protection

### Features

- Safety light curtain AOPD type 4 or type 2
- Beam resolution 14, 20, 30, 40 and 90 mm
- Protection field heights 150 – 1800 mm
- Extensive accessories



**With 3-Zone alignment indication**

### Functions suitable for every protection task

All important contactless safety functions on machines and equipment can be realized by means of the two function versions, Standard and Select, of the SLC series.

### Advantages

#### Higher equipment availability

- Stable, trouble-free operation with the slender and torsion-resistant housing
- Parameterization without PC or DIP switch through simple wiring in the control cabinet
- The integrated Double-Scan technology avoids unwanted shutdown even in harsh operating conditions
- Clear diagnostic and status messages in the 7-segment display ensure shorter downtimes
- Cable lengths up to 100 m with unshielded connection cables ensure greater operational flexibility and reduce costs even under difficult EMC conditions

#### Faster during commissioning, operation and service

- The 3-zone alignment indicator reduces assembly time and justage
- The wide range of SLC products permits optimal and cost-effective design of protective devices
- Easy to connect via standard M12 connection technology
- Fast installation and removal on the machine through a system configuration in the control cabinet
- Selectable transmission channels and range reduction prevent mutual interference
- Simplified planning of safeguards and less type diversity because very SLC safety light curtain from 0 m to the maximum range can be implemented

Function overview	SLC Standard	SLC Select
LED display	√	√
Double-scan technology	√	√
Range reduction	√	√
Selectable transmission channels	√	√
7-segment display		√
Automatic start	√	√
Manual start / restart interlock		√
External device monitoring (EDM)		√

# SLC – safety light curtain

## Technical data

<b>Function</b>		safety light curtain
Function display		LED
<b>Power supply circuit</b>		
Rated voltage $U_N$		24 V DC
Current consumption (transmitter)		50 mA
Current consumption, no load (receiver/transceiver)		150 mA
Operating voltage range $U_B$		0.8 - 1.2 x $U_N$
Electrical isolation supply circuit - control circuit		no
<b>Protection field data</b>	Resolution	Range / protective field height
	14 mm (nur SLC-4)	0 - 6 m / 150 - 1800 mm
	20 mm	0 - 15 m / 150 - 1800 mm
	30 mm	0 - 10 m / 150 - 1800 mm
	40 mm	0 - 20 m / 150 - 1800 mm
	90 mm	0 - 20 m / 600 - 1800 mm
<b>Output circuit OSSD</b>		
Number		2
Type		Transistor outputs PNP
Short-circuit monitoring		yes
Switching current (max., per output)		380 mA
Leakage current (max.)		200 $\mu$ A
Switching voltage, high active ( $U_B - 1V$ )		18.0 - 27.0 V
Switching voltage, low		0 - 2,5 V
Line resistance / line length		< 200 $\Omega$ / $\leq$ 100 m
Response time		device-dependent
<b>General data</b>		
Creepage distances and clearances between the circuits		EN 60664-1
Protection degree according to EN 60529		IP65
Ambient temperature / storage temperature		0 °C - +55 °C / -25 °C - + 70 °C
Connection		M12 (5 pole / 8 pole) device-dependent
Weight		0.3 - 1.95 kg, device-dependent
Standards		EN 61496, EN ISO 13849-1, EN 62061
Approvals		TÜV, c-CSA-us

Finger, hand and arm protection on machines with the safety light curtain SLC



## SLC 2 – safety light curtain

### Device overview | order numbers Transmitter

Protective field height hhhh [mm]	Resolution	20 mm	30 mm	40 mm	90 mm
	Type	SLC-2TR20-hhhh	SLC-2TR30-hhhh	SLC-2TR40-hhhh	SLC-2TR90-hhhh
0150		R1.512.0150.0	R1.513.0150.0	R1.514.0150.0	-
0225		R1.512.0225.0	R1.513.0225.0	R1.514.0225.0	-
0300		R1.512.0300.0	R1.513.0300.0	R1.514.0300.0	-
0450		R1.512.0450.0	R1.513.0450.0	R1.514.0450.0	-
0600		R1.512.0600.0	R1.513.0600.0	R1.514.0600.0	R1.515.0600.0
0750		R1.512.0750.0	R1.513.0750.0	R1.514.0750.0	R1.515.0750.0
0900		R1.512.0900.0	R1.513.0900.0	R1.514.0900.0	R1.515.0900.0
1050		R1.512.1050.0	R1.513.1050.0	R1.514.1050.0	R1.515.1050.0
1200		R1.512.1200.0	R1.513.1200.0	R1.514.1200.0	R1.515.1200.0
1350		R1.512.1350.0	R1.513.1350.0	R1.514.1350.0	R1.515.1350.0
1500		R1.512.1500.0	R1.513.1500.0	R1.514.1500.0	R1.515.1500.0
1650		R1.512.1650.0	R1.513.1650.0	R1.514.1650.0	R1.515.1650.0
1800		R1.512.1800.0	R1.513.1800.0	R1.514.1800.0	R1.515.1800.0

### Device overview | order numbers Receiver Standard

Protective field height hhhh [mm]	Resolution	20 mm	30 mm	40 mm	90 mm
	Type	SLC-2ST20-hhhh	SLC-2ST30-hhhh	SLC-2ST40-hhhh	SLC-2ST90-hhhh
0150		R1.522.0150.0	R1.523.0150.0	R1.524.0150.0	-
0225		R1.522.0225.0	R1.523.0225.0	R1.524.0225.0	-
0300		R1.522.0300.0	R1.523.0300.0	R1.524.0300.0	-
0450		R1.522.0450.0	R1.523.0450.0	R1.524.0450.0	-
0600		R1.522.0600.0	R1.523.0600.0	R1.524.0600.0	R1.525.0600.0
0750		R1.522.0750.0	R1.523.0750.0	R1.524.0750.0	R1.525.0750.0
0900		R1.522.0900.0	R1.523.0900.0	R1.524.0900.0	R1.525.0900.0
1050		R1.522.1050.0	R1.523.1050.0	R1.524.1050.0	R1.525.1050.0
1200		R1.522.1200.0	R1.523.1200.0	R1.524.1200.0	R1.525.1200.0
1350		R1.522.1350.0	R1.523.1350.0	R1.524.1350.0	R1.525.1350.0
1500		R1.522.1500.0	R1.523.1500.0	R1.524.1500.0	R1.525.1500.0
1650		R1.522.1650.0	R1.523.1650.0	R1.524.1650.0	R1.525.1650.0
1800		R1.522.1800.0	R1.523.1800.0	R1.524.1800.0	R1.525.1800.0

### Device overview | order numbers Receiver Select

Protective field height hhhh [mm]	Resolution	20 mm	30 mm	40 mm	90 mm
	Type	SLC-2SL20-hhhh	SLC-2SL30-hhhh	SLC-2SL40-hhhh	SLC-2SL90-hhhh
0150		R1.532.0150.0	R1.533.0150.0	R1.534.0150.0	-
0225		R1.532.0225.0	R1.533.0225.0	R1.534.0225.0	-
0300		R1.532.0300.0	R1.533.0300.0	R1.534.0300.0	-
0450		R1.532.0450.0	R1.533.0450.0	R1.534.0450.0	-
0600		R1.532.0600.0	R1.533.0600.0	R1.534.0600.0	R1.535.0600.0
0750		R1.532.0750.0	R1.533.0750.0	R1.534.0750.0	R1.535.0750.0
0900		R1.532.0900.0	R1.533.0900.0	R1.534.0900.0	R1.535.0900.0
1050		R1.532.1050.0	R1.533.1050.0	R1.534.1050.0	R1.535.1050.0
1200		R1.532.1200.0	R1.533.1200.0	R1.534.1200.0	R1.535.1200.0
1350		R1.532.1350.0	R1.533.1350.0	R1.534.1350.0	R1.535.1350.0
1500		R1.532.1500.0	R1.533.1500.0	R1.534.1500.0	R1.535.1500.0
1650		R1.532.1650.0	R1.533.1650.0	R1.534.1650.0	R1.535.1650.0
1800		R1.532.1800.0	R1.533.1800.0	R1.534.1800.0	R1.535.1800.0

# SLC 4 – safety light curtain

## Device overview | order numbers Transmitter

Protective field height hhhh [mm]	Resolution	14 mm	20 mm	30 mm	40 mm	90 mm
	Type	SLC-4TR14-hhhh	SLC-4TR20-hhhh	SLC-4TR30-hhhh	SLC-4TR40-hhhh	SLC-4TR90-hhhh
0150		R1.541.0150.0	R1.542.0150.0	R1.543.0150.0	R1.544.0150.0	-
0225		-	R1.542.0225.0	R1.543.0225.0	R1.544.0225.0	-
0300		R1.541.0300.0	R1.542.0300.0	R1.543.0300.0	R1.544.0300.0	-
0450		R1.541.0450.0	R1.542.0450.0	R1.543.0450.0	R1.544.0450.0	-
0600		R1.541.0600.0	R1.542.0600.0	R1.543.0600.0	R1.544.0600.0	R1.545.0600.0
0750		R1.541.0750.0	R1.542.0750.0	R1.543.0750.0	R1.544.0750.0	R1.545.0750.0
0900		R1.541.0900.0	R1.542.0900.0	R1.543.0900.0	R1.544.0900.0	R1.545.0900.0
1050		R1.541.1050.0	R1.542.1050.0	R1.543.1050.0	R1.544.1050.0	R1.545.1050.0
1200		R1.541.1200.0	R1.542.1200.0	R1.543.1200.0	R1.544.1200.0	R1.545.1200.0
1350		R1.541.1350.0	R1.542.1350.0	R1.543.1350.0	R1.544.1350.0	R1.545.1350.0
1500		R1.541.1500.0	R1.542.1500.0	R1.543.1500.0	R1.544.1500.0	R1.545.1500.0
1650		R1.541.1650.0	R1.542.1650.0	R1.543.1650.0	R1.544.1650.0	R1.545.1650.0
1800		R1.541.1800.0	R1.542.1800.0	R1.543.1800.0	R1.544.1800.0	R1.545.1800.0

## Device overview | order numbers Receiver Standard

Protective field height hhhh [mm]	Resolution	14 mm	20 mm	30 mm	40 mm	90 mm
	Type	SLC-4ST14-hhhh	SLC-4ST20-hhhh	SLC-4ST30-hhhh	SLC-4ST40-hhhh	SLC-4ST90-hhhh
0150		R1.551.0150.0	R1.552.0150.0	R1.553.0150.0	R1.554.0150.0	-
0225		-	R1.552.0225.0	R1.553.0225.0	R1.554.0225.0	-
0300		R1.551.0300.0	R1.552.0300.0	R1.553.0300.0	R1.554.0300.0	-
0450		R1.551.0450.0	R1.552.0450.0	R1.553.0450.0	R1.554.0450.0	-
0600		R1.551.0600.0	R1.552.0600.0	R1.553.0600.0	R1.554.0600.0	R1.555.0600.0
0750		R1.551.0750.0	R1.552.0750.0	R1.553.0750.0	R1.554.0750.0	R1.555.0750.0
0900		R1.551.0900.0	R1.552.0900.0	R1.553.0900.0	R1.554.0900.0	R1.555.0900.0
1050		R1.551.1050.0	R1.552.1050.0	R1.553.1050.0	R1.554.1050.0	R1.555.1050.0
1200		R1.551.1200.0	R1.552.1200.0	R1.553.1200.0	R1.554.1200.0	R1.555.1200.0
1350		R1.551.1350.0	R1.552.1350.0	R1.553.1350.0	R1.554.1350.0	R1.555.1350.0
1500		R1.551.1500.0	R1.552.1500.0	R1.553.1500.0	R1.554.1500.0	R1.555.1500.0
1650		R1.551.1650.0	R1.552.1650.0	R1.553.1650.0	R1.554.1650.0	R1.555.1650.0
1800		R1.551.1800.0	R1.552.1800.0	R1.553.1800.0	R1.554.1800.0	R1.555.1800.0

## Device overview | order numbers Receiver Select

Protective field height hhhh [mm]	Resolution	14 mm	20 mm	30 mm	40 mm	90 mm
	Type	SLC-4SL14-hhhh	SLC-4SL20-hhhh	SLC-4SL30-hhhh	SLC-4SL40-hhhh	SLC-4SL90-hhhh
0150		R1.561.0150.0	R1.562.0150.0	R1.563.0150.0	R1.564.0150.0	-
0225		-	R1.562.0225.0	R1.563.0225.0	R1.564.0225.0	-
0300		R1.561.0300.0	R1.562.0300.0	R1.563.0300.0	R1.564.0300.0	-
0450		R1.561.0450.0	R1.562.0450.0	R1.563.0450.0	R1.564.0450.0	-
0600		R1.561.0600.0	R1.562.0600.0	R1.563.0600.0	R1.564.0600.0	R1.565.0600.0
0750		R1.561.0750.0	R1.562.0750.0	R1.563.0750.0	R1.564.0750.0	R1.565.0750.0
0900		R1.561.0900.0	R1.562.0900.0	R1.563.0900.0	R1.564.0900.0	R1.565.0900.0
1050		R1.561.1050.0	R1.562.1050.0	R1.563.1050.0	R1.564.1050.0	R1.565.1050.0
1200		R1.561.1200.0	R1.562.1200.0	R1.563.1200.0	R1.564.1200.0	R1.565.1200.0
1350		R1.561.1350.0	R1.562.1350.0	R1.563.1350.0	R1.564.1350.0	R1.565.1350.0
1500		R1.561.1500.0	R1.562.1500.0	R1.563.1500.0	R1.564.1500.0	R1.565.1500.0
1650		R1.561.1650.0	R1.562.1650.0	R1.563.1650.0	R1.564.1650.0	R1.565.1650.0
1800		R1.561.1800.0	R1.562.1800.0	R1.563.1800.0	R1.564.1800.0	R1.565.1800.0

## SLD – safety light grid



### Personal protection function

The SLD safety light grids are especially suitable for the contactless safeguarding of hazardous areas and for personal protection on machines and equipment.

### Advantages

#### Faster during commissioning, operation and service

- The integrated laser alignment aid (optional) permits precise mounting and reduces the startup times of the SLD system
- Robust device columns with spring-loaded base mounting and integrated alignment aid are available for the free-standing implementation
- Muting applications can be easily implemented with **samos**<sup>®</sup> or **samos**<sup>®</sup> PRO

### Applications

- Access security (personal protection)
- Safeguarding of hazardous areas

### Features

- Safety light grid AOPD type 4
- 2-, 3- and 4-beam resolutions
- Also available as an universal system, i.e. transmitter/receiver in a single unit
- High ranges up to 70 m can be implemented
- Extensive accessories

**Integrated laser alignment aid**



#### Increased reliability

- Robust aluminum housing in IP67
- Operating temperature range -30 °C to 55 °C permits implementation even in the harshest environments
- Multi-beam scanning avoids unwanted shutdown
- Mutual interference is avoided through the adjustable range reduction when implementing multiple systems
- Parameterization without PC or DIP switch through simple wiring in the control cabinet

Function overview	SLD Standard	SLD Select	SLD Universal Standard	SLD Universal Select
LED display	√	√	√	√
Multi-scan technology	√	√	√	√
Range reduction	√	√		
Laser alignment aid (optional)	√	√		
Automatic start	√	√	√	√
Manual start / restart interlock		√		√
External device monitoring (EDM)		√		√
Transceiver system			√	√

# SLD – safety light grid

## Technical data

<b>Function</b>		safety light grid
Function display		LED
<b>Power supply circuit</b>		
Rated voltage $U_N$		24 V DC
Current consumption (transmitter)		50 mA
Current consumption, no load (receiver/transceiver)		150 mA
Operating voltage range $U_B$		$0.8 - 1.2 \times U_N$
Electrical isolation supply circuit - control circuit		no
<b>Protection field data</b>		
	Beams	Range
	2	0.5 - 50 m / 20 - 70 m / 0.5 - 8 m
	3	0.5 - 50 m / 20 - 70 m / 0.5 - 6 m
	4	0.5 - 50 m / 20 - 70 m
<b>Output circuit OSSD</b>		
Number		2
Type		Transistor outputs PNP
Short-circuit monitoring		ja
Switching current (max., per output)		380 mA
Leakage current (max.)		200 $\mu$ A
Switching voltage, high active ( $U_B - 1V$ )		18.0 - 27.8 V
Switching voltage, low		0 - 2,5 V
Line resistance / line length		< 200 $\Omega$
Response time		25 ms
<b>General data</b>		
Creepage distances and clearances between the circuits		EN 60664-1
Protection degree according to EN 60529		IP67
Ambient temperature / storage temperature		-30 °C - +55 °C / -40 °C - + 75 °C
Connection		M12 (5 pole / 8 pole) device-dependent
Weight		1.4 - 2.2 kg, device-dependent
Standards		EN 61496, EN ISO 13849-1, EN 62061
Approvals		TÜV, c-CSA-us

**Note:** For the connection of safety light grids SLD shielded cables are mandatory.

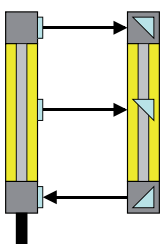

### SLD Universal – Less cabling expenditure

The safety light grids consist of an integrated SLD universal transmitter/receiver unit and a passive reflector unit without electrical connection.

- 2- and 3-beam systems
- Range 0.5 to 8 m

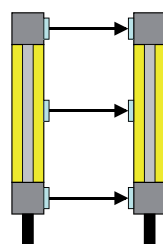

### SLD Standard / SLD Select

The safety light grid and SLD Standard and SLD Select each consist of a transmitter and a receiver unit and are thus suitable for highest ranges.

- 2-, 3- and 4-beam systems
- Ranges 0.5 - 50 m and 20 - 70 m

## SLD – safety light grids

### Device overview | order numbers Transmitter

Type	Actuator	Part. no.	Std. pack
SLD-4TR2-0-50	Transmitter, 2 beams, range 50 m	R1.641.2050.0	1
SLD-4TR2-0-70	Transmitter, 2 beams, range 70 m	R1.641.2070.0	1
SLD-4TR2-1-50	Transmitter, 2 beams, range 50 m, laser alignment aid	R1.641.2150.0	1
SLD-4TR2-1-70	Transmitter, 2 beams, range 70 m, laser alignment aid	R1.641.2170.0	1
SLD-4TR3-0-50	Transmitter, 3 beams, range 50 m	R1.641.3050.0	1
SLD-4TR3-0-70	Transmitter, 3 beams, range 70 m	R1.641.3070.0	1
SLD-4TR3-1-50	Transmitter, 3 beams, range 50 m, laser alignment aid	R1.641.3150.0	1
SLD-4TR3-1-70	Transmitter, 3 beams, range 70 m, laser alignment aid	R1.641.3170.0	1
SLD-4TR4-0-50	Transmitter, 4 beams, range 50 m	R1.641.4050.0	1
SLD-4TR4-0-70	Transmitter, 4 beams, range 70 m	R1.641.4070.0	1
SLD-4TR4-1-50	Transmitter, 4 beams, range 50 m, laser alignment aid	R1.641.4150.0	1
SLD-4TR4-1-70	Transmitter, 4 beams, range 70 m, laser alignment aid	R1.641.4170.0	1

### Device overview | order numbers Receiver Standard

Type	Actuator	Part. no.	Std. pack
SLD-4ST2-0-50	Receiver-Standard, 2 beams, range 50 m	R1.642.2050.0	1
SLD-4ST2-0-70	Receiver-Standard, 2 beams, range 70 m	R1.642.2070.0	1
SLD-4ST2-1-50	Receiver-Standard, 2 beams, range 50 m, laser alignment aid	R1.642.2150.0	1
SLD-4ST2-1-70	Receiver-Standard, 2 beams, range 70 m, laser alignment aid	R1.642.2170.0	1
SLD-4ST3-0-50	Receiver-Standard, 3 beams, range 50 m	R1.642.3050.0	1
SLD-4ST3-0-70	Receiver-Standard, 3 beams, range 70 m	R1.642.3070.0	1
SLD-4ST3-1-50	Receiver-Standard, 3 beams, range 50 m, laser alignment aid	R1.642.3150.0	1
SLD-4ST3-1-70	Receiver-Standard, 3 beams, range 70 m, laser alignment aid	R1.642.3170.0	1
SLD-4ST4-0-50	Receiver-Standard, 4 beams, range 50 m	R1.642.4050.0	1
SLD-4ST4-0-70	Receiver-Standard, 4 beams, range 70 m	R1.642.4070.0	1
SLD-4ST4-1-50	Receiver-Standard, 4 beams, range 50 m, laser alignment aid	R1.642.4150.0	1
SLD-4ST4-1-70	Receiver-Standard, 4 beams, range 70 m, laser alignment aid	R1.642.4170.0	1

### Device overview | order numbers Receiver Select

Type	Actuator	Part. no.	Std. pack
SLD-4SL2-0-50	Receiver-Select, 2 beams, range 50 m	R1.643.2050.0	1
SLD-4SL2-0-70	Receiver-Select, 2 beams, range 70 m	R1.643.2070.0	1
SLD-4SL2-1-50	Receiver-Select, 2 beams, range 50 m, laser alignment aid	R1.643.2150.0	1
SLD-4SL2-1-70	Receiver-Select, 2 beams, range 70 m, laser alignment aid	R1.643.2170.0	1
SLD-4SL3-0-50	Receiver-Select, 3 beams, range 50 m	R1.643.3050.0	1
SLD-4SL3-0-70	Receiver-Select, 3 beams, range 70 m	R1.643.3070.0	1
SLD-4SL3-1-50	Receiver-Select, 3 beams, range 50 m, laser alignment aid	R1.643.3150.0	1
SLD-4SL3-1-70	Receiver-Select, 3 beams, range 70 m, laser alignment aid	R1.643.3170.0	1
SLD-4SL4-0-50	Receiver-Select, 4 beams, range 50 m	R1.643.4050.0	1
SLD-4SL4-0-70	Receiver-Select, 4 beams, range 70 m	R1.643.4070.0	1
SLD-4SL4-1-50	Receiver-Select, 4 beams, range 50 m, laser alignment aid	R1.643.4150.0	1
SLD-4SL4-1-70	Receiver-Select, 4 beams, range 70 m, laser alignment aid	R1.643.4170.0	1

### Device overview | order numbers Universal

Type	Actuator	Part. no.	Std. pack
SLD-4US2-0-00	Universal-Standard, 2 beams	R1.644.2000.0	1
SLD-4US3-0-00	Universal-Standard, 3 beams	R1.644.3000.0	1
SLD-4UL2-0-00	Universal-Select, 2 beams	R1.645.2000.0	1
SLD-4UL3-0-00	Universal-Select, 3 beams	R1.645.3000.0	1
SLD-MIR2-0-08	Mirror, 2 beams, range 8 m	R1.606.2008.0	1
SLD-MIR3-0-06	Mirror, 3 beams, range 6 m	R1.606.3006.0	1
SLD-MIR3-0-08	Mirror, 3 beams, range 8 m	R1.606.3008.0	1

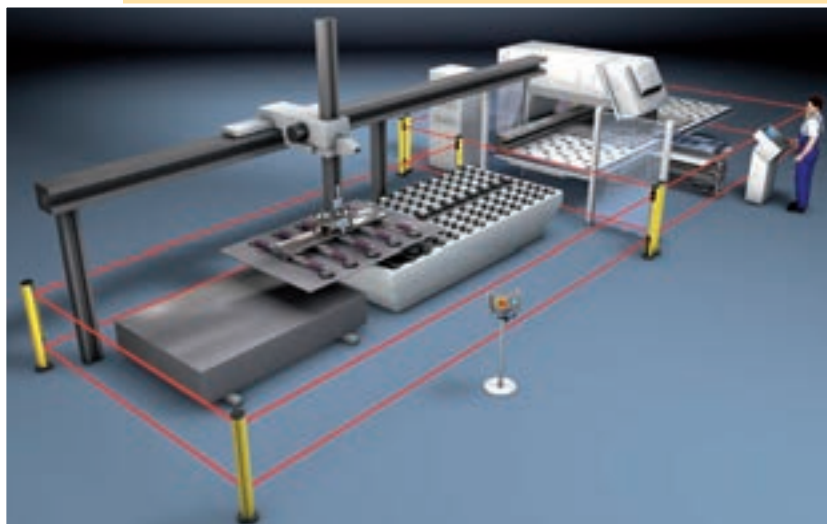

Safeguarding of a machine with safety light grids

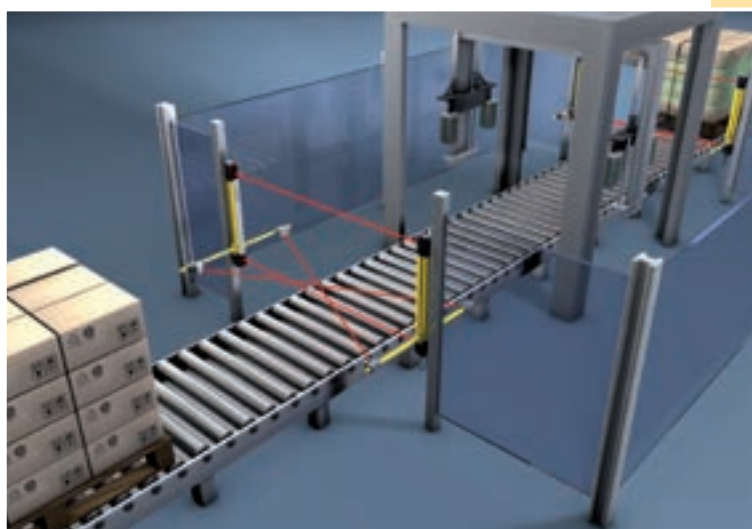

Parallel muting with SLD and SLX-MUTC-SET2P



**SLD – Muting functions with *samos*<sup>PRO</sup>**

SLD safety light grids are ideally suited for monitoring material locks, such as in the packaging industry, in combination with the freely configurable muting function blocks of *samos*<sup>PRO</sup>, for example in the packaging industry.



## Mounting accessories – Series SLC



SLX-MO-RO1

The swivel mount set **SLX-MO-RO1** is used for wall mounting of series SLC (360° horizontal adjustment possible).

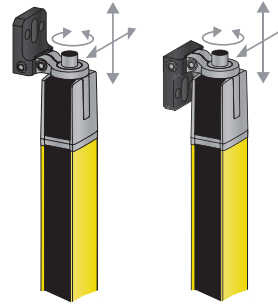

## Mounting accessories – Series SLD



SLX-MO-RO-SET1

The swivel mount set **SLX-MO-RO-SET1 (SLX-MO-RO-SET1S** with shock absorber) is used for wall mounting of Transmitter, Receiver and Transceiver from series SLD (240° horizontal adjustment possible).

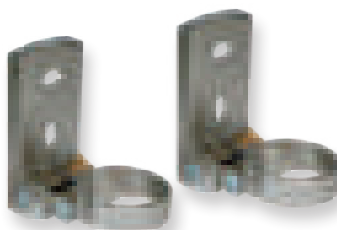

SLX-MO-RO-SET2

The swivel mount set **SLX-MO-RO-SET2 (SLX-MO-RO-SET2S** with shock absorber) is used for wall mounting of Mirror from series SLD (240° horizontal adjustment possible).

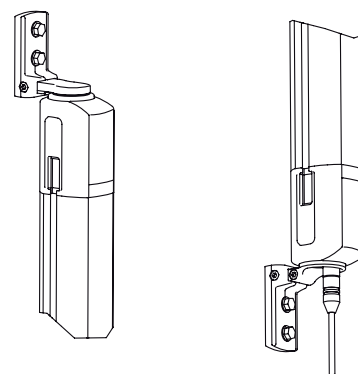

### Overview of devices | part numbers

Type	Description	Part no.	Std. pack
SLX-MO-RO1	Rotative bracket 360°, 2 pcs., inkl. 1 pcs. SLC cylinder	R1.591.0006.0	1
SLX-MO-RO-SET1	Set with SLX-MO-RO-B + SLX-MO-RO-C + screws	R1.591.0011.0	1
SLX-MO-RO-SET2	Set with 2 x SLX-MO-RO-C + screws	R1.591.0012.0	1
SLX-MO-RO-SET1-S	Set with SLX-MO-RO-B, SLX-MO-RO-C + screws + Shockabsorber	R1.591.0013.0	1
SLX-MO-RO-SET2-S	Set with 2 x SLX-MO-RO-C + screws + Shockabsorber	R1.591.0014.0	1

## Mounting accessories – Series SLC/SLD

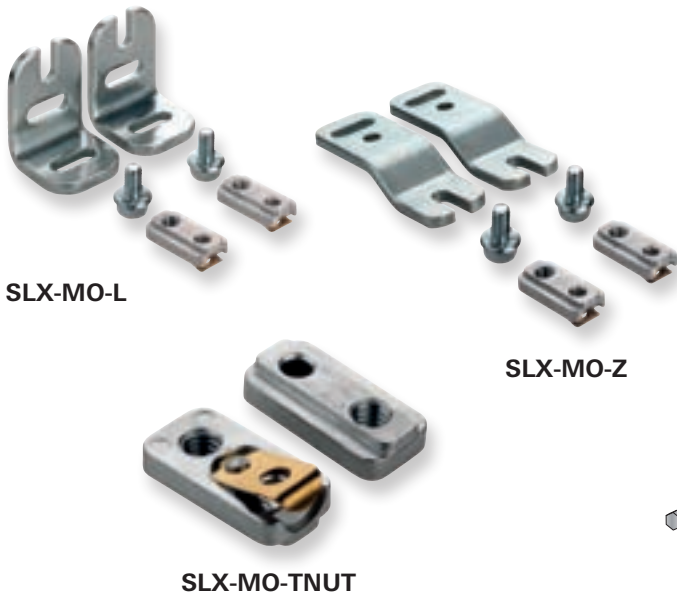

The **SLX-MO-TNUT** sets including sliding blocks for mounting of series SLC/SLD.

The **SLX-MO-L** and **SLX-MO-Z** sets are used for wall mounting of series SLC/SLD in combination with sliding blocks SLX-MO-TNUT.

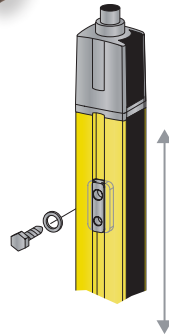

The **SLX-MO-CLIP** is used for fixed mounting of series SLC/SLD in device columns SLX-COL.

The swiveling mounting brackets **SLX-MO-RO-S** and **SLX-MO-RO270-S** are used for mounting series SLC/SLD in device columns SLX-COL. These brackets are adjustable and with vibration damping.

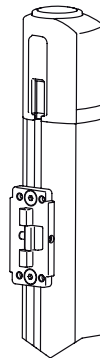

### Overview of devices | part numbers

Type	Description	Part no.	Std. pack
SLX-MO-L	L-Bracket, 2 pcs.	R1.591.0004.0	1
SLX-MO-Z	Z-Bracket, 2 pcs.	R1.591.0005.0	1
SLX-MO-TNUTM6	Set Slot nut with M6-screw thread, 10 pcs.	R1.591.0001.0	1
SLX-MO-TNUTM6M4	Set Slot nut with M6- and M4-screw thread, 10 pcs.	R1.591.0002.0	1
SLX-MO-TNUTM6M5	Set Slot nut with M6- and M5-screw thread, 10 pcs.	R1.591.0003.0	1
SLX-MO-RO-S	Rotative bracket with Shockabsorber, 70mm lang, 2 pcs.	R1.591.0007.0	1
SLX-MO-RO270-S	Rotative bracket with Shockabsorber, 270mm lang, 2 pcs.	R1.591.0008.0	1
SLX-MO-CLIP	Clamp bracket, for Installation in Device column	R1.591.0009.0	1
SLX-MO-CLIP2	Set Clamp bracket, for Installation in Device column, 2 pcs.	R1.591.0010.0	1

## Mounting accessories – Series SLC/SLD



**SLX-CAB-M12-xxxxx**

### Connection cables SLC/SLD

The connection cables **SLX-CAB-M12-xxxxx** (shielded and unshielded) are used for the electrical connection of series SLC/SLD by M12-connector (5- or 8-pole). For the connection of safety light grids SLD shielded cables are mandatory.



**SLC-PRO-xxxx**

### Protective screen SLC

The protective screens **SLC-PRO** are used for the protection of the front of series SLC.

### Overview of devices | part numbers

Type	Description	Part no.	Std. pack
SLX-CAB-M12-S0505	Connection cable M12, 5-pole, Length 5m, shielded	R1.600.0505.0	1
SLX-CAB-M12-S0510	Connection cable M12, 5-pole, Length 10m, shielded	R1.600.0510.0	1
SLX-CAB-M12-S0515	Connection cable M12, 5-pole, Length 15m, shielded	R1.600.0515.0	1
SLX-CAB-M12-S0525	Connection cable M12, 5-pole, Length 25m, shielded	R1.600.0525.0	1
SLX-CAB-M12-S0550	Connection cable M12, 5-pole, Length 50m, shielded	R1.600.0550.0	1
SLX-CAB-M12-S0805	Connection cable M12, 8-pole, Length 5m, shielded	R1.600.0805.0	1
SLX-CAB-M12-S0810	Connection cable M12, 8-pole, Length 10m, shielded	R1.600.0810.0	1
SLX-CAB-M12-S0815	Connection cable M12, 8-pole, Length 15m, shielded	R1.600.0815.0	1
SLX-CAB-M12-S0825	Connection cable M12, 8-pole, Length 25m, shielded	R1.600.0825.0	1
SLX-CAB-M12-S0850	Connection cable M12, 8-pole, Length 50m, shielded	R1.600.0850.0	1
SLX-CAB-M12-0505	Connection cable M12, 5-pole, Length 5m, unshielded	R1.500.0505.0	1
SLX-CAB-M12-0510	Connection cable M12, 5-pole, Length 10m, unshielded	R1.500.0510.0	1
SLX-CAB-M12-0515	Connection cable M12, 5-pole, Length 15m, unshielded	R1.500.0515.0	1
SLX-CAB-M12-0525	Connection cable M12, 5-pole, Length 25m, unshielded	R1.500.0525.0	1
SLX-CAB-M12-0550	Connection cable M12, 5-pole, Length 50m, unshielded	R1.500.0550.0	1
SLX-CAB-M12-0805	Connection cable M12, 8-pole, Length 5m, unshielded	R1.500.0805.0	1
SLX-CAB-M12-0810	Connection cable M12, 8-pole, Length 10m, unshielded	R1.500.0810.0	1
SLX-CAB-M12-0815	Connection cable M12, 8-pole, Length 15m, unshielded	R1.500.0815.0	1
SLX-CAB-M12-0825	Connection cable M12, 8-pole, Length 25m, unshielded	R1.500.0825.0	1
SLX-CAB-M12-0850	Connection cable M12, 8-pole, Length 50m, unshielded	R1.500.0850.0	1
SLC-PRO-0150	SLC-Protective glass, Length: 148 mm	R1.502.0150.0	1
SLC-PRO-0225	SLC-Protective glass, Length: 223 mm	R1.502.0225.0	1
SLC-PRO-0300	SLC-Protective glass, Length: 298 mm	R1.502.0300.0	1
SLC-PRO-0450	SLC-Protective glass, Length: 448 mm	R1.502.0450.0	1
SLC-PRO-0600	SLC-Protective glass, Length: 598 mm	R1.502.0600.0	1
SLC-PRO-0750	SLC-Protective glass, Length: 748 mm	R1.502.0750.0	1
SLC-PRO-0900	SLC-Protective glass, Length: 898 mm	R1.502.0900.0	1
SLC-PRO-1050	SLC-Protective glass, Length: 1048 mm	R1.502.1050.0	1
SLC-PRO-1200	SLC-Protective glass, Length: 1198 mm	R1.502.1200.0	1
SLC-PRO-1350	SLC-Protective glass, Length: 1348 mm	R1.502.1350.0	1
SLC-PRO-1500	SLC-Protective glass, Length: 1498 mm	R1.502.1500.0	1
SLC-PRO-1650	SLC-Protective glass, Length: 1648 mm	R1.502.1650.0	1
SLC-PRO-1800	SLC-Protective glass, Length: 1798 mm	R1.502.1800.0	1
SLC-PRO-FIX2	Mounting bracket for SLC-Protective glass, 2 pcs.	R1.502.0002.0	1
SLC-PRO-FIX3	Mounting bracket for SLC-Protective glass, 3 pcs.	R1.502.0003.0	1

## Reflectors and reflector columns – Series SLC/SLD

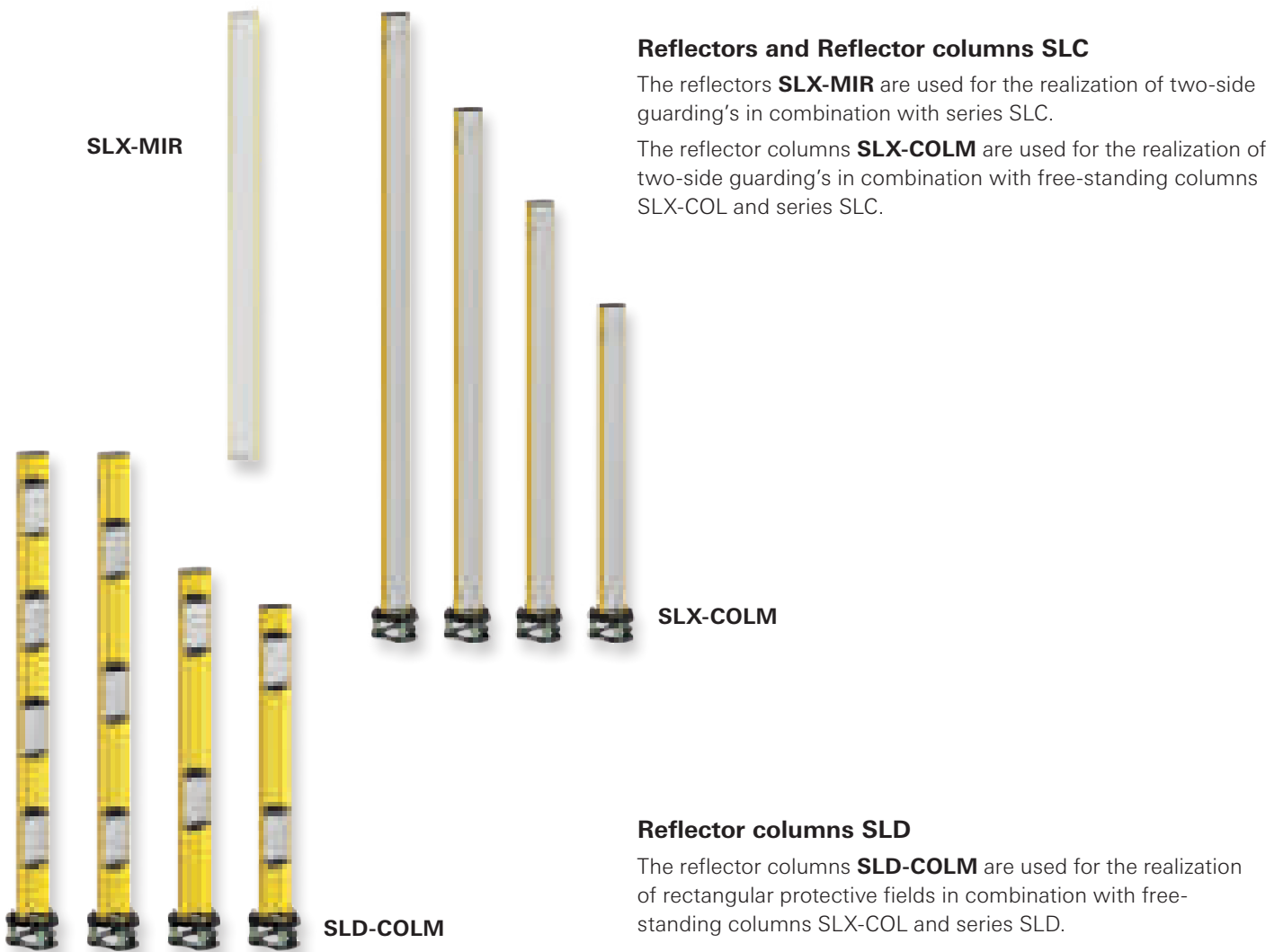

### Reflectors and Reflector columns SLC

The reflectors **SLX-MIR** are used for the realization of two-side guarding's in combination with series SLC.

The reflector columns **SLX-COLM** are used for the realization of two-side guarding's in combination with free-standing columns SLX-COL and series SLC.

### Reflector columns SLD

The reflector columns **SLD-COLM** are used for the realization of rectangular protective fields in combination with free-standing columns SLX-COL and series SLD.

### Overview of devices | part numbers

Type	Description	Part no.	Std. pack
SLX-COLM-1000	Reflector column, persistent 1000 mm	R1.594.1000.0	1
SLX-COLM-1300	Reflector column, persistent 1300 mm	R1.594.1300.0	1
SLX-COLM-1600	Reflector column, persistent 1600 mm	R1.594.1600.0	1
SLX-COLM-1900	Reflector column, persistent 1900 mm	R1.594.1900.0	1
SLX-MIR-0150	Reflector, length: 210 mm	R1.595.0150.0	1
SLX-MIR-0300	Reflector, length: 360 mm	R1.595.0300.0	1
SLX-MIR-0450	Reflector, length: 510 mm	R1.595.0450.0	1
SLX-MIR-0600	Reflector, length: 660 mm	R1.595.0600.0	1
SLX-MIR-0750	Reflector, length: 810 mm	R1.595.0750.0	1
SLX-MIR-0900	Reflector, length: 960 mm	R1.595.0900.0	1
SLX-MIR-1050	Reflector, length: 1110 mm	R1.595.1050.0	1
SLX-MIR-1200	Reflector, length: 1260 mm	R1.595.1200.0	1
SLX-MIR-1350	Reflector, length: 1410 mm	R1.595.1350.0	1
SLX-MIR-1500	Reflector, length: 1560 mm	R1.595.1500.0	1
SLX-MIR-1650	Reflector, length: 1710 mm	R1.595.1650.0	1
SLX-MIR-1800	Reflector, length: 1860 mm	R1.595.1800.0	1
SLX-MIR-FIX2	Bracket for SLX-MIR-reflector, 2 pcs.	R1.595.0002.0	1
SLD-COLM2-0900	Reflector column, Reflector distance: 500 mm; Total height: 900 mm	R1.604.0900.0	1
SLD-COLM2-1060	Reflector column, Reflector distance: 500 mm; Total height: 1060 mm	R1.604.1060.0	1
SLD-COLM3-1360	Reflector column, Reflector distance: 400 mm; Total height: 1360 mm	R1.604.1363.0	1
SLD-COLM4-1360	Reflector column, Reflector distance: 300 mm; Total height: 1360 mm	R1.604.1364.0	1
SLD-MIR	Replacement reflector for SLD-Reflector columnn	R1.604.0001.0	1

## Device columns – Series SLC/SLD



SLX-COL



The device columns **SLX-COL** are used for a free-standing installation of series SLC/SLD.



### Overview of devices | part numbers

Type	Description	Part no.	Std. pack
SLX-COL-0900	Device column, profile height: 820 mm; Total height: 900 mm	R1.593.0900.0	1
SLX-COL-1000	Device column, profile height: 980 mm; Total height: 1060 mm	R1.593.1000.0	1
SLX-COL-1300	Device column, profile height: 1280 mm; Total height: 1360 mm	R1.593.1300.0	1
SLX-COL-1600	Device column, profile height: 1580 mm; Total height: 1660 mm	R1.593.1600.0	1
SLX-COL-1900	Device column, profile height: 1880 mm; Total height: 1960 mm	R1.593.1900.0	1
SLX-COL-2500	Device column, profile height: 2480 mm; Total height: 2560 mm	R1.593.2500.0	1
SLX-COL-BASE	Replacement pedestal for columns with spring elements	R1.593.0001.0	1
SLX-COLP-0900	2 Protective glasses for SLC-COL-Device column; Length: 820 mm	R1.592.0900.0	1
SLX-COLP-1000	2 Protective glasses for SLX-COL-Device column; Length: 980 mm	R1.592.1000.0	1
SLX-COLP-1300	2 Protective glasses for SLX-COL-Device column; Length: 1280 mm	R1.592.1300.0	1
SLX-COLP-1600	2 Protective glasses for SLX-COL-Device column; Length: 1580 mm	R1.592.1600.0	1
SLX-COLP-1900	2 Protective glasses for SLX-COL-Device column; Length: 1880 mm	R1.592.1900.0	1

## Other accessories – Series SLD/SLC



SLX-ACC-LASER



SLX-ACC-LASERCOL

The external laser-alignment device **SLX-ACC-LASER** (for direct mounting on series SLX/SLD) and **SLX-ACC-LASERCOL** (for mounting on a device column SLX-COL) are used for the adjustment of the optical system of series SLC/SLD.

The test rods **SLX-ACC-TEST** are used for functional testing of protective areas realized by series SLC.



SLX-ACC-TEST

### Overview of devices | part numbers

Type	Description	Part no.	Std. pack
SLX-ACC-LASERCOL	External laser adjustment device, for fixing in Device column	R1.596.0003.0	1
SLX-ACC-LASER	External laser adjustment device	R1.596.0002.0	1
SLX-ACC-TEST2040	Test bar, 20/40 mm	R1.596.2040.0	1
SLX-ACC-TEST1430	Test bar, 14/30 mm	R1.596.1430.0	1
SLX-ACC-MKEY	Magnet Key for activation of laser adjustment device	R1.596.0001.0	1

## Muting accessories – Series SLC/SLD



SLX-MUTC-SET2P

The **SLX-MUTC-SET2P** muting set is required to set-up a 2-sensor parallel muting (cross muting) system, e.g. in combination with the SLX-COL device columns to be ordered separately, or directly onto the SLD safety light grids.

The **SLX-MUTC-SET4** muting set is used to set-up a 4-sensor sequential muting system, e.g. in combination with the SLX-COL device columns to be ordered separately, or directly onto the SLD safety light grids.

The **SLX-MUTC-SET2A** or **SLX-MUTC-SET2B** muting sets (see figure below) are used to set-up a 2-sensor sequential muting system, e.g. in combination with the SLX-COL device columns to be ordered separately, or directly onto the SLD safety light grids.

### Overview of devices | part numbers

Type	Description	Part no.	Std. pack
SLX-MUTC-SET2P	SLX-muting-sensor-set (device column) for 2-sensor-parallel-muting, incl. 2 sensor units, 2 reflector units, pre-assembled, distance 8 m, 2 m cable with plug M12	R1.597.0008.0	1
SLX-MUTC-SET4	SLX-muting-sensor-set for 4-sensor-sequential-muting, incl. 4 sensor units, 4 reflector units, pre-assembled, distance 8 m, 2 m cable with plug M12	R1.597.0007.0	1
SLX-MUTC-SET2A	SLX-muting-sensor-set for 2-sensor-sequential-muting, incl. 2 sensor units, 2 reflector units, pre-assembled, distance 8 m, 2 m cable with plug M12	R1.597.0005.0	1
SLX-MUTC-SET2B	SLX-muting-sensor-set for 2-sensor-sequential-muting, incl. 2 sensor units, 2 reflector units, pre-assembled, distance 8 m, 2 m cable with plug M12	R1.597.0006.0	1
SLX-MUT-SENS20	Sensor element, 2 m cable with plug M12	R1.597.0012.0	1
SLX-MUT-SENS07	Sensor element, 0.7 m cable with plug M12	R1.597.0013.0	1
SLX-MUT-SENS04	Sensor element, 0.4 m cable with plug M12	R1.597.0014.0	1
SLX-MUT-REFLEX	Reflector	R1.597.0015.0	1
SLX-MUT-BOX4	Sensor connector box for 4 muting sensors	R1.597.0020.0	1
SLX-MUT-BOX4-BT	Sensor connector box for 4 muting sensors, with mounting plate	R1.597.0019.0	1
SLX-MUT-BOX4-BT-L	Sensor connector box for 4 muting sensors, with L-mounting bracket	R1.597.0021.0	1

sensor PRO

Further muting accessories are available on request.

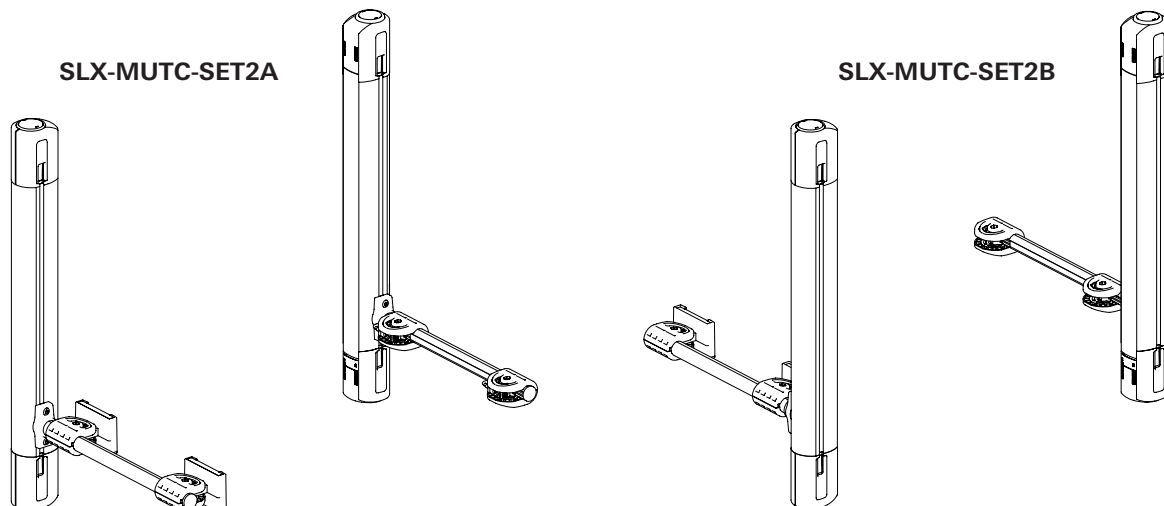

## SNH – Emergency stop buttons

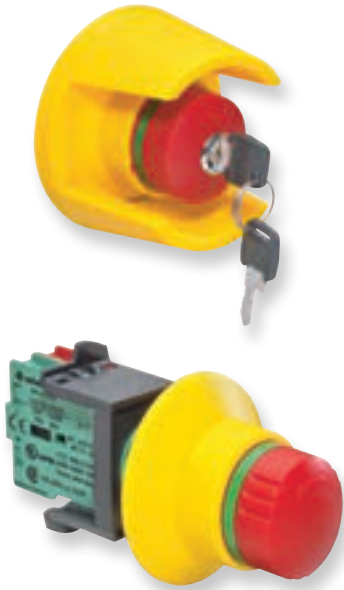

### Function

Emergency stop buttons of the SNH series are used on or near machines for the protection of persons. They serve the purpose of switching off / stopping machines and systems to avoid or reduce emerging or existing hazards to persons. Emergency stop buttons of the SNH series are also used to avoid damage to the machine or working material.

### Applications

- Machine and plant manufacturing
- Building machinery and transport technology

### Features

- For applications up to IP69K
- Tamper-proof according to EN 418/EN ISO 13850
- Modular design
- Turn-to-reset
- Integrated illumination
- Optical indication of the switching state
- Up to PL e/Category 4 (EN ISO 13849-1)
- Up to SIL<sub>CL</sub> 3 (EN 62061)

- **Modular design** – The emergency stop buttons of the SNH series have a modular design, various actuating elements can be freely combined with the chosen contact design.
- **Failure protection** – The emergency stop buttons of the SNH series have a special failure protection that automatically detects when a contact block is removed from the respective actuating element and then switches off safely.

### Dimension diagram

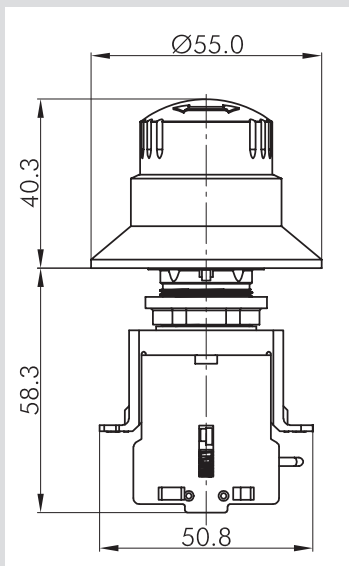

### Cut-out dimensions

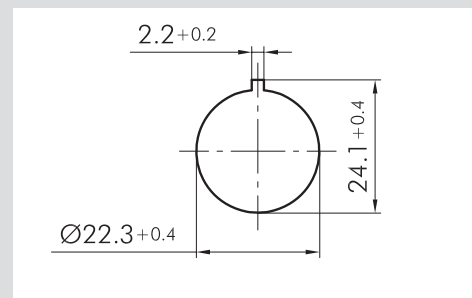

# SNH – Emergency stop buttons

## Technical data

Function	
According to EN 418/EN ISO 13850	Emergency stop button
Actuator	
Housing material	Plastic
Protection degree	IP 65
Operating ambient temperature	-30 – +70 °C (without illumination), -30 – +55 °C (with illumination)
Storage temperature	-50 – +85 °C
Switching cycles	> 50000
Max. torque	2.5 Nm
Installation diameter	22.3 mm
Contact blocks	
Contact type	NC contact NC contact with failure protection NO contact
Contact material	AgNi
Switching principle	Slow-action contact
Actuating travel	6 mm
Mechanical service life	1 x 10 <sup>7</sup> switching cycles
Electrical service life	1 x 10 <sup>6</sup> switching cycles
Application category	AC15 A600: 250 V, 3A DC13 Q600: 24 V, 2A
Protection class	II
Rated insulation voltage	600 V
Min. Switching voltage	5 V
Min. Switching current	1 mA
Thermal continuous current I <sub>th</sub>	16 A
Max. through-type thermistor	20 mΩ
Max. bounce time	20 ms
Min. positive opening travel	3 mm
Operating ambient temperature	-30 – +85 °C
Storage temperature	-50 – +85 °C
Connection technology	Screw connection
Conductor cross-section	Max. 2,5 mm <sup>2</sup>
Standards	EN 418 /EN ISO 13850
Approvals	TÜV, cULus

# SNH – Emergency stop buttons

## Contact blocks



SNH 0001



SNH 0002

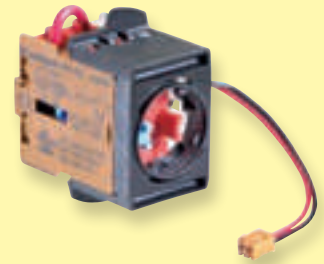
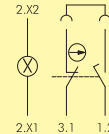

SNH 0003

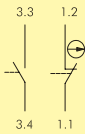

SNH 0011

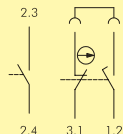

SNH 0012

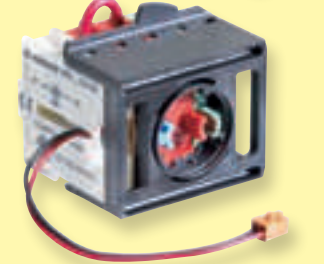
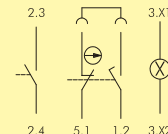

SNH 0013

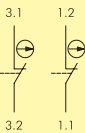

SNH 0021

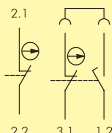

SNH 0022

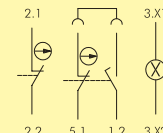

SNH 0023

## Actuating elements



SNH 0100

SNH 0400 (with illumination)



SNH 0200



SNH 0300

(up to IP 69K)



SNH 0500



**SNH – safe.**

# SNH – Emergency stop buttons

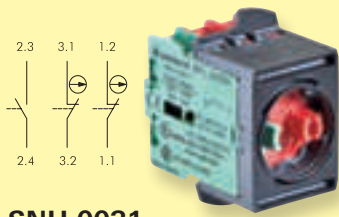

SNH 0031

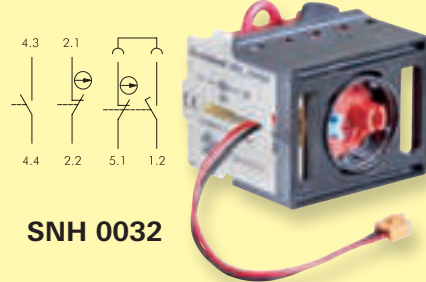

SNH 0032

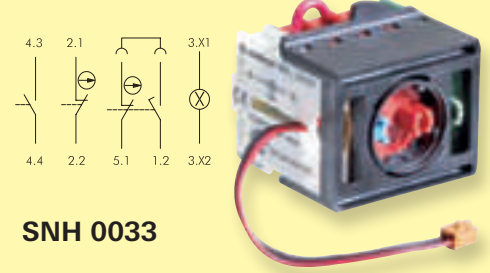

SNH 0033

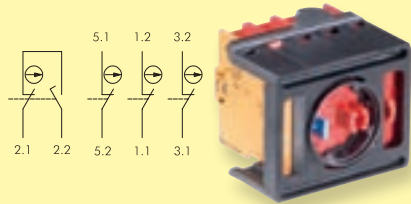

SNH 0043

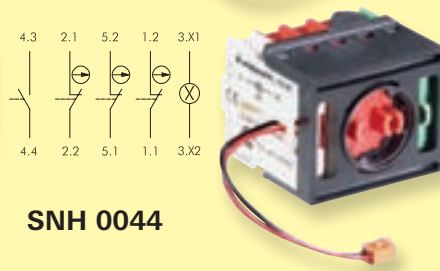

SNH 0044



SNH 0600



SNH 0700

## Housing



SNH 6001



simple. modular.



# SNH – Emergency stop buttons

## Dimension diagram

### Actuating elements

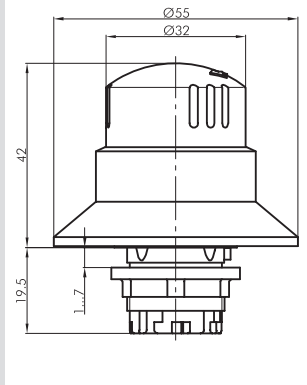

**SNH 0100**  
**SNH 0400**

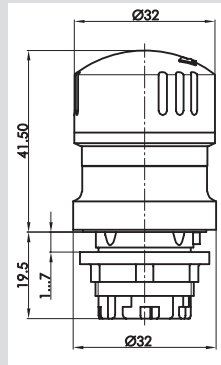

**SNH 0200**

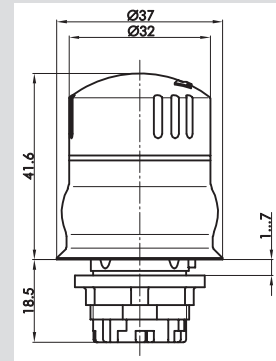

**SNH 0300**

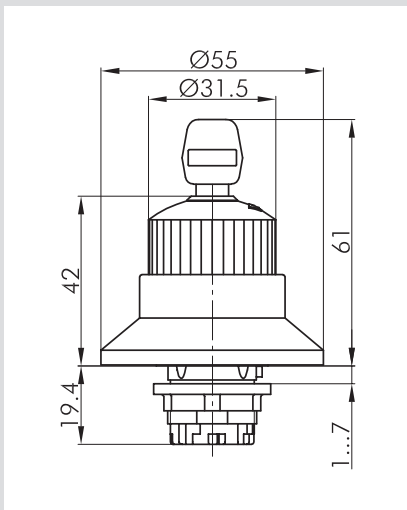

**SNH 0500**

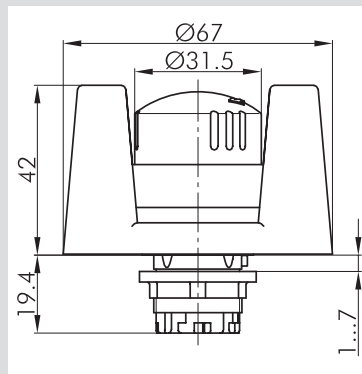

**SNH 0600**

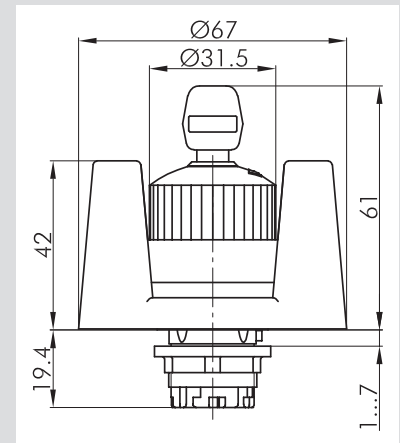

**SNH 0700**

### Housing

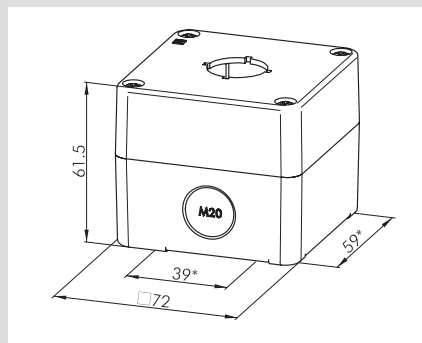

**SNH 6001**

# SNH – Emergency stop buttons

## Dimension diagram

### Contact blocks

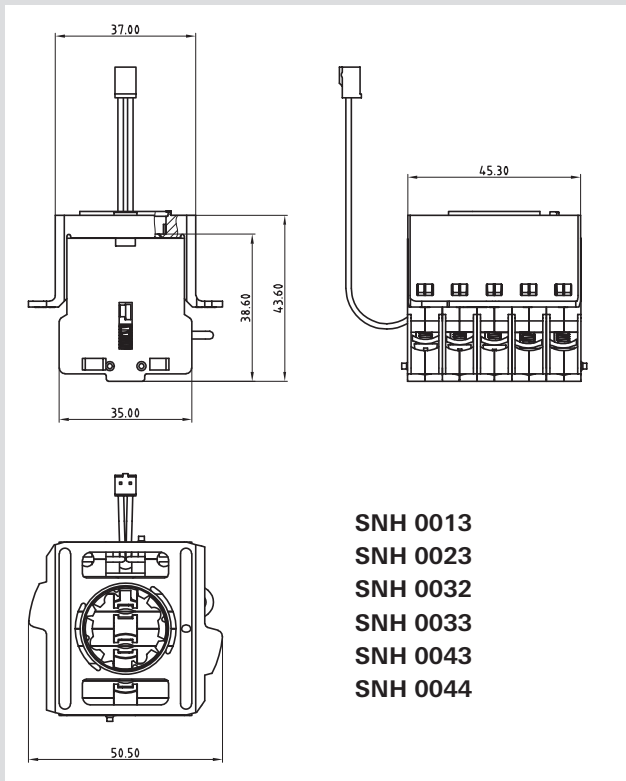

- SNH 0013
- SNH 0023
- SNH 0032
- SNH 0033
- SNH 0043
- SNH 0044

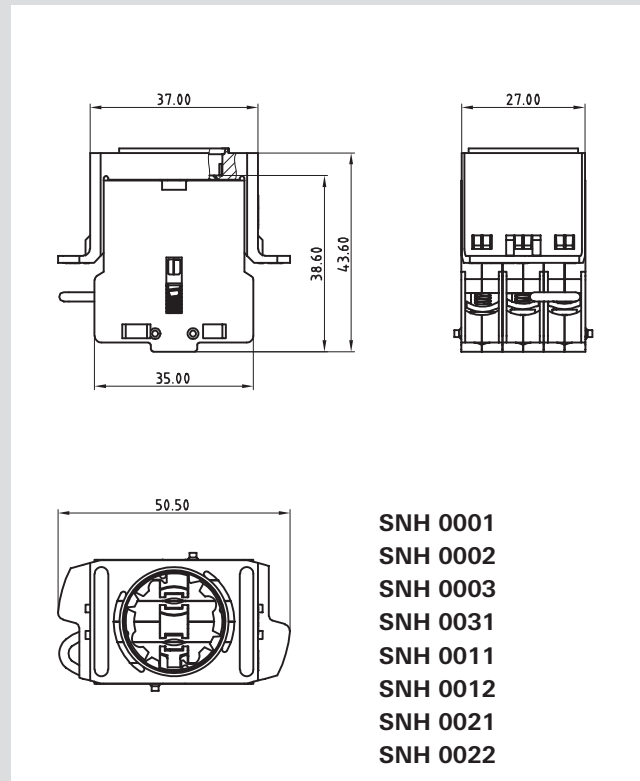

- SNH 0001
- SNH 0002
- SNH 0003
- SNH 0031
- SNH 0011
- SNH 0012
- SNH 0021
- SNH 0022

## Overview of devices | part numbers

Type	Description	Part no.	Std. pack
SNH 0001	Contact block, 1 NC	R1.200.0001.0	1
SNH 0002	Contact block, 1 NC (failure protection)	R1.200.0002.0	1
SNH 0003	Contact block, 1 NC (failure protection) / illumination	R1.200.0003.0	1
SNH 0011	Contact block, 1 NC / 1 NO	R1.200.0011.0	1
SNH 0012	Contact block, 1 NC (failure protection) / 1 NO	R1.200.0012.0	1
SNH 0013	Contact block, 1 NC (failure protection) / 1 NO / illumination	R1.200.0013.0	1
SNH 0021	Contact block, 2 NC	R1.200.0021.0	1
SNH 0022	Contact block, 2 NC (failure protection)	R1.200.0022.0	1
SNH 0023	Contact block, 2 NC (failure protection) / illumination	R1.200.0023.0	1
SNH 0031	Contact block, 2 NC / 1 NO	R1.200.0031.0	1
SNH 0032	Contact block, 2 NC (failure protection) / 1 NO	R1.200.0032.0	1
SNH 0033	Contact block, 2 NC (failure protection) / 1 NO / illumination	R1.200.0033.0	1
SNH 0043	Contact block, 4 NC (failure protection)	R1.200.0043.0	1
SNH 0044	Contact block, 3 NC / 1 NO / illumination	R1.200.0044.0	1
SNH 0200	Actuator (with actuation indication)	R1.200.0200.0	1
SNH 0300	Actuator IP69 (without actuation indication)	R1.200.0300.0	1
SNH 0100	Actuator (with actuation indication)	R1.200.0100.0	1
SNH 0400	Actuator (with actuation indication + illumination)	R1.200.0400.0	1
SNH 0500	Actuator (with actuation indication + key release)	R1.200.0500.0	1
SNH 0600	Actuator (with actuation indication + protective collar)	R1.200.0600.0	1
SNH 0700	Actuator (with actuation indication, protective collar and key release)	R1.200.0700.0	1
SNH 1101	Emergency stop button (SNH 0100, 1 NC)	R1.200.1101.0	1
SNH 1102	Emergency stop button (SNH 0100, 1 NC (failure protection))	R1.200.1102.0	1
SNH 1111	Emergency stop button (SNH 0100, 1 NC / 1 NO)	R1.200.1111.0	1
SNH 1112	Emergency stop button (SNH 0100, 1 NC (failure protection) / 1 NO)	R1.200.1112.0	1
SNH 1121	Emergency stop button (SNH 0100, 2 NC)	R1.200.1121.0	1
SNH 1122	Emergency stop button (SNH 0100, 2 NC (failure protection))	R1.200.1122.0	1
SNH 1131	Emergency stop button (SNH 0100, 2 NC / 1 NO)	R1.200.1131.0	1
SNH 1132	Emergency stop button (SNH 0100, 2 NC (failure protection) / 1 NO)	R1.200.1132.0	1
SNH 1143	Emergency stop button (SNH 0100, 4 NC (failure protection))	R1.200.1143.0	1
SNH 6001	Housing IP67	R1.200.6001.0	1
SNH 6010	Emergency stop adhesive plate	R1.200.6010.0	10

# SIN – Safety switch with separated actuator and guard locking



## Applications

- Personnel protection on machines with dangerous machine parts which move after switching off
- Locking of a machine or an automatic process when the guard is open
- Position monitoring of guard and guard locking

## Features

- Suitable for locking devices in accordance with EN 14119
- Flexible use with 4 horizontal or 4 vertical actuating directions
- Integrated protection against simple bypassing
- Long service life thanks to dust- and water-proof housing and a broad operating temperature range of up to 70°C
- Locking force 1,500 N

## Function

The mechanical safety switches in the SIN series are suitable for the secure locking (guard locking) of safety doors until a hazardous machine process has ended.

The safety switches have two independent contact blocks which reflect the position of the actuator on the one hand and the position of the guard locking on the other.

The release of the entry or a shutdown of the machine in case of danger is done by evaluating the contact blocks by a suitable basic device **safe** RELAY or through the **samos**<sup>®</sup> or **samos**<sup>®</sup>PRO safety systems.

## Spring-actuated locking

The safety switch on the guard is locked automatically when the actuator reaches its end position.

The guard is unlocked by applying a current to the internal electromagnets in the safety switch.

## Magnet-actuated locking

The safety switch on the guard is locked when the actuator reaches its end position by applying a current to the internal electromagnet.

When the current to the internal electromagnet is switched off, the guard locking is released and the guard can be opened.

## Versatile installation

Thanks to the adjustable actuator head and the large selection of actuators, the safety switch can be used to implement guard locking devices for all applications in machine construction.

Universal use through 8 different actuating directions and 5 different actuators:

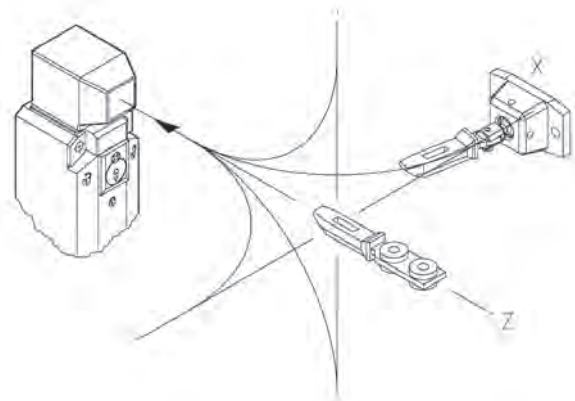

# SIN – Safety switch with separated actuator and guard locking

## Technical data

<b>Function</b>	
according EN 14119	Safety switch with separated actuator and guard locking
<b>Power supply circuit</b>	
Rated voltage	24 V AC/DC, 110/230 V AC
Continuous output	4.4 VA (SIN 12xx: 8 VA)
<b>Output circuit</b>	
Contact load of conv. thermal current $I_{th}$	5 A
Application category	AC-15: $U_e$ 230V, $I_e$ 2,5 A
Mechanical life	1 x 10 <sup>6</sup> switching cycles (max. 600 switching cycles)
Short-circuit protection	lead fuse 4 A class gL
<b>Mechanical data</b>	
Guard locking force	1500 Nm
Extraction force	> 27 Nm
Approach speed	max. 0,5 m/s
Dimensions (L x W x H)	170 x 42.5 x 51 mm
Mounting	4 x M5
Cable entry point	3 x M20 x 1,5
<b>General data</b>	
Ambient temperature	-25 - +70 °C
Wire ranges push-in terminals	1 x 0.5 -1.5 mm <sup>2</sup>
Protection degree according to EN 60529	IP 67
Weight	0,35 kg
Standards	EN 60947-1, EN 60947-5-1, EN ISO 13849-1, EN 62061
Approvals	DEGUV, c-CSA-us, CCC

# SIN – Safety switch with separated actuator and guard locking

## Dimensions diagramm

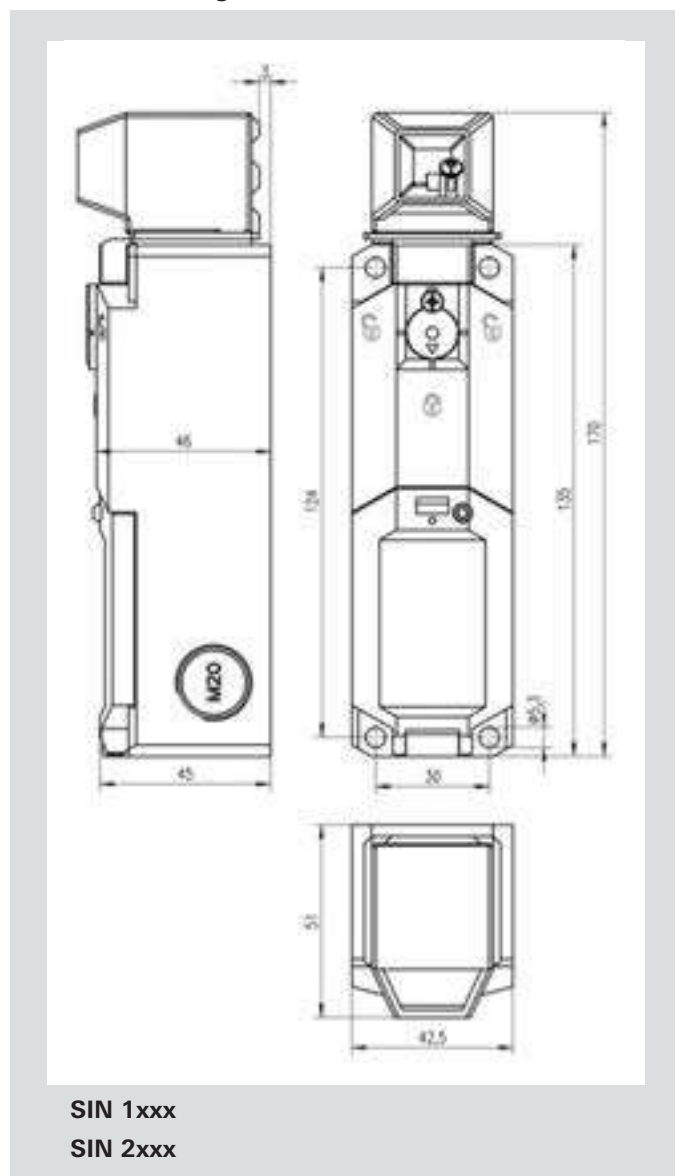

## Overview of devices | part numbers safety switch

Type *	Locking principle	Contact assignment (actuator + guard locking)	Rated voltage	Additional features	Part. no.	Std. pack
SIN 1120	Spring-actuated	2NC + 2NC	24 V AC/DC	Auxiliary release	R1.310.1120.0	1
SIN 1150	Spring-actuated	1NC/1NO + 1NC/1NO	24 V AC/DC	Auxiliary release	R1.310.1150.0	1
SIN 1130	Spring-actuated	2NC + 1NC/1NO	24 V AC/DC	Auxiliary release	R1.310.1130.0	1
SIN 1330	Spring-actuated	2NC + 1NC/1NO	24 V AC/DC	Auxiliary release, LED	R1.310.1330.0	1
SIN 1350	Spring-actuated	1NC/1NO + 1NC/1NO	24 V AC/DC	Auxiliary release, LED	R1.310.1350.0	1
SIN 1220	Spring-actuated	2NC + 2NC	110/230 V AC	Auxiliary release	R1.310.1220.0	1
SIN 1250	Spring-actuated	1NC/1NO + 1NC/1NO	110/230 V AC	Auxiliary release	R1.310.1250.0	1
SIN 1230	Spring-actuated	2NC + 1NC/1NO	110/230 V AC	Auxiliary release	R1.310.1230.0	1
SIN 2120	Magnet-actuated	2NC + 2NC	24 V AC/DC		R1.310.2120.0	1
SIN 2150	Magnet-actuated	1NC/1NO + 1NC/1NO	24 V AC/DC		R1.310.2150.0	1
SIN 2130	Magnet-actuated	2NC + 1NC/1NO	24 V AC/DC		R1.310.2130.0	1
SIN 2220	Magnet-actuated	2NC + 2NC	110/230 V AC		R1.310.2220.0	1
SIN 2250	Magnet-actuated	1NC/1NO + 1NC/1NO	110/230 V AC		R1.310.2250.0	1
SIN 2230	Magnet-actuated	2NC + 1NC/1NO	110/230 V AC		R1.310.2230.0	1

\* the associated actuator must be ordered separately

# SIN – Actuator

## Dimensions diagramm

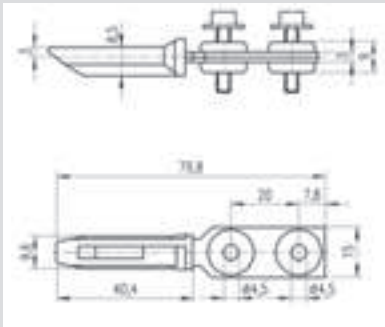

SIN 9001

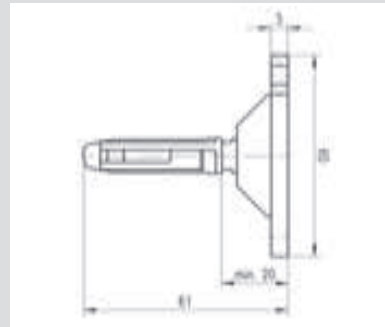

SIN 9004

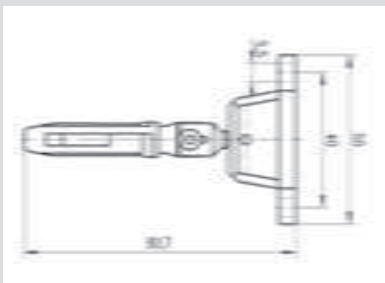

SIN 9002

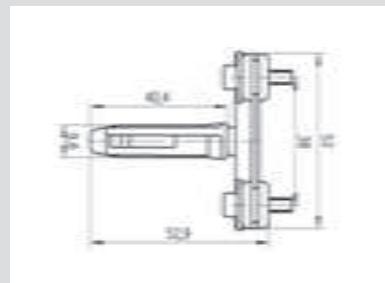

SIN 9005

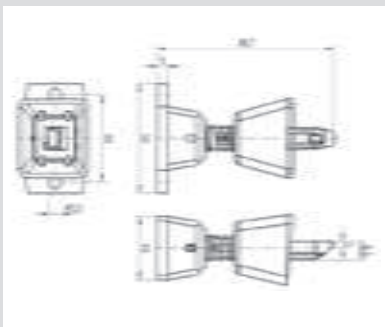

SIN 9003

### Approach Radii

SIN 9001, 9003, 9005: R min > 400mm

SIN 9004 R min > 350mm

SIN 9002 R min > 150mm

## Overview of devices | part numbers Actuator

Type	Actuator	Part. no.	Std. pack
SIN 9001	Standard actuator	R1.310.9001.0	1
SIN 9002	Radius actuator	R1.310.9002.0	1
SIN 9003	Radius actuator with dust protection	R1.310.9003.0	1
SIN 9004	Actuator, flexible	R1.310.9004.0	1
SIN 9005	Actuator, transverse	R1.310.9005.0	1

## SMS – Safety switch with separated actuator



SMS 4xxx



SMS 3xxx

### Applications

- Access protection for operators of machines with dangerous machine parts which move after switching off
- Locking of a machine or an automatic process when the guard is open
- Position monitoring of movable guards in accordance with EN 60947-5-3

### Features

- Flexible use with 2 horizontal or 2 vertical actuating directions
- Protection against simple bypassing in accordance with EN 14119 through multiple coding of the actuator
- Long service life thanks to dust- and water-proof housing and a broad operating temperature range of up to 80 °C.
- Increased extraction force up to 30 N
- Easy installation with adjustment via slots and final fixing via round holes



### Function

The mechanical safety switches in the SMS 2000, SMS 3000 and SMS 4000 series are suitable for the reliable position monitoring of movable guards (EN 60947-5-3).

If the associated guard on the machine is opened, the hazardous machine movement is switched off.

The machine is shut down in a hazardous situation by an analysis of the contacts carried out by a suitable basic device in the **safe** RELAY or by one of the **samos**® or **samos**®PRO safety systems.

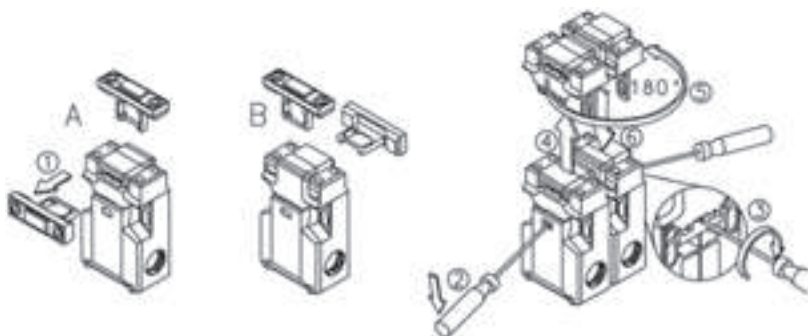

Simple installation and wiring in each application.

# SMS – Safety switch with separated actuator



SMS 2xxx

### Applications

- Access protection for operators of machines with dangerous machine parts which move after switching off
- Locking of a machine or an automatic process when the guard is open
- Position monitoring of guard and guard locking

### Features

- Flexible use with 4 horizontal or 4 vertical actuating directions
- Slim design for installation on profile systems and where there are difficult space constraints
- Protection against simple bypassing in accordance with EN 1088 through multiple coding of the actuator
- Long service life thanks to dust- and water-proof housing and a broad operating temperature range of up to 80 °C
- Increased extraction force up to 50 N



### Technical data

Function	
according EN 14119	Safety switch with separated actuator
Power supply circuit	
Max. continuous thermal current $I_{th}$	5 A (contact assignment 1 NC or 2 NC/1 NO) 10 A (contact assignment 1 NC/1 NO or 2 NC)
Application category	AC-15: 230 V, 1.5 A (contact assignment 1 NC or 2 NC/1 NO) AC-15: 230 V, 3 A (contact assignment 1 NC/1 NO or 2 NC)
Mechanical life	$1 \times 10^6$
Short-circuit protection	SMS 2xxx / SMS 3xxx lead fuse 6 A class gL/gG SMS 4xxx lead fuse 10 A class gL/gG
Mechanical data	
Approach speed	$\leq 0,2$ m/s
Extraction force	SMS 2xxx 10 N (increased extraction force 50 N) SMS 3xxx / SMS 4xxx 10 N (increased extraction force 30 N)
Dimensions (L x W x H)	SMS 2xxx 100 x 31 x 30,5 mm SMS 3xxx 75 x 52 x 33 mm SMS 4xxx 90 x 52 x 33,5 mm
Mounting	2 x M5
Cable entry point	SMS 2xxx 1 x M20 x 1.5 SMS 3xxx 3 x M16 x 1.5 SMS 4xxx 3 x M20 x 1.5
General data	
Ambient temperature	-30 - +80 °C
Wire ranges screw terminals	1 x 0.5 - 1.5 mm <sup>2</sup>
Protection degree according to EN 60529	IP 65
Weight	0,15 kg
Standards	EN 60947-1, EN 60947-5-1, EN ISO 13849-1, EN 62061
Approvals	TÜV, UL, c-CSA-us

## SMS – Safety switch with separated actuator

### Dimensions diagramm

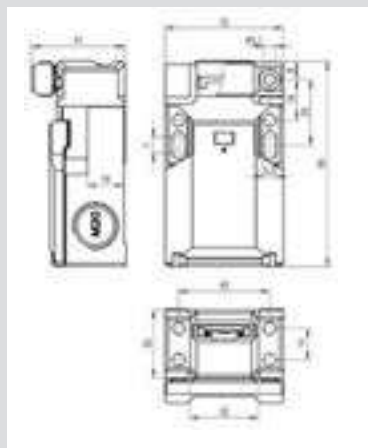

**SMS 4xxx**

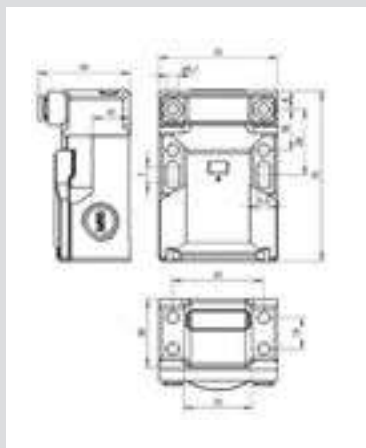

**SMS 3xxx**

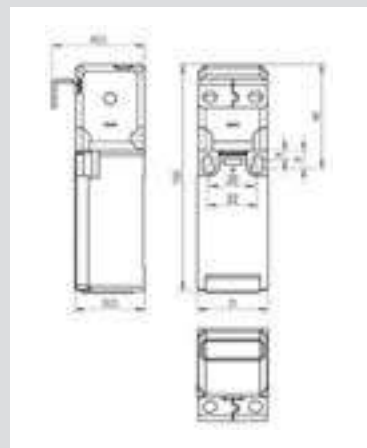

**SMS 2xxx**

### Overview of devices | part numbers safety switch

Type	Actuator*	Contact assignment	Extraction force	Part no.	Std. pack
SMS 3010	Standard actuator	1NC	10 N	R1.320.3010.0	1
SMS 3210	Actuator for increased force	1NC	30 N	R1.320.3210.0	1
SMS 3110	Radius actuator	1NC	10 N	R1.320.3110.0	1
SMS 4040	Standard actuator	1NC/1NO	10 N	R1.320.4040.0	1
SMS 4240	Actuator for increased force	1NC/1NO	30 N	R1.320.4240.0	1
SMS 4140	Radius actuator	1NC/1NO	10 N	R1.320.4140.0	1
SMS 4020	Standard actuator	2NC	10 N	R1.320.4020.0	1
SMS 4220	Actuator for increased force	2NC	30 N	R1.320.4220.0	1
SMS 4120	Radius actuator	2NC	10 N	R1.320.4120.0	1
SMS 4070	Standard actuator	2NC/1NO	10 N	R1.320.4070.0	1
SMS 4270	Actuator for increased force	2NC/1NO	30 N	R1.320.4270.0	1
SMS 4170	Radius actuator	2NC/1NO	10 N	R1.320.4170.0	1
SMS 2040	Standard actuator 2	1NC/1NO	10 N	R1.320.2040.0	1
SMS 2240	Actuator for increased force	1NC/1NO	50 N	R1.320.2240.0	1
SMS 2020	Standard actuator 2	2NC	10 N	R1.320.2020.0	1
SMS 2220	Actuator for increased force	2NC	50 N	R1.320.2220.0	1
SMS 2070	Standard actuator 2	2NC/1NO	10 N	R1.320.2070.0	1
SMS 2270	Actuator for increased force	2NC/1NO	50 N	R1.320.2270.0	1

\* The relevant actuator is included in the scope of delivery

# SMS – Actuator



**SMS 9001**  
(SMS 3xxx / SMS 4xxx included in the scope of delivery)



**SMS 9002**



**SMS 9003**



**SMS 9004**  
(SMS 2xxx included in the scope of delivery)

## Dimensions diagramm

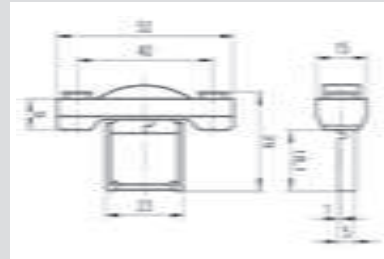

SMS 9001

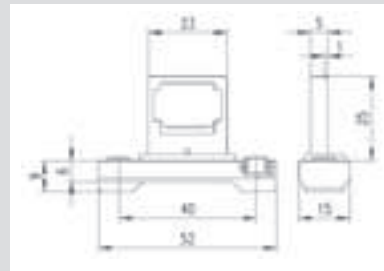

SMS 9002

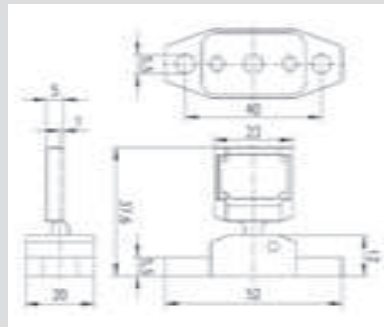

SMS 9003

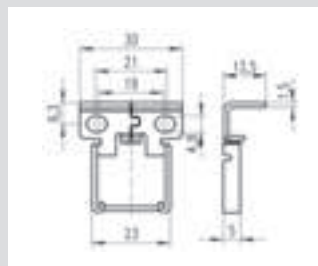

SMS 9004

## Overview of devices | part numbers Actuator

Type	Actuator	Part no.	Std. pack
SMS 9001	Standard actuator	R1.320.9001.0	1
SMS 9002	Actuator for increased force	R1.320.9002.0	1
SMS 9003	Radius actuator	R1.320.9003.0	1
SMS 9004	Standard actuator 2	R1.320.9004.0	1

# STS – Non-contact safety switches with coding



### Applications

- Protection of people or machines
- Position monitoring of machine parts
- Position monitoring of doors and switches of isolating protective devices

### Features

- Individual coding for maximum manipulation protection
- Up to PL e / category 4 (EN 13849-1)
- Up to SIL<sub>CL</sub> 3 (EN 62061)
- Up to 30 sensors can be cascaded
- Automatic or manual start
- LED and semiconductor output for diagnostics
- Switching distance of 8 mm / 10 mm
- Protection class IP67 / IP69K

### Function

The non-contact safety switches from the STS series are used for monitoring the position of machine parts and the position of doors and switches of isolating protective devices.

The STS series features integrated evaluation and built-in manipulation protection.

In the event of a hazard, access is approved or the machine is shut down, for example, by a device from the **safe** RELAY series or the **samos**®/**samos**®PRO safety system or by the safety switch directly.

Safety switches from the STS series are also able to switch larger loads without wear via safe outputs (OSSDs).

### Circuit diagram

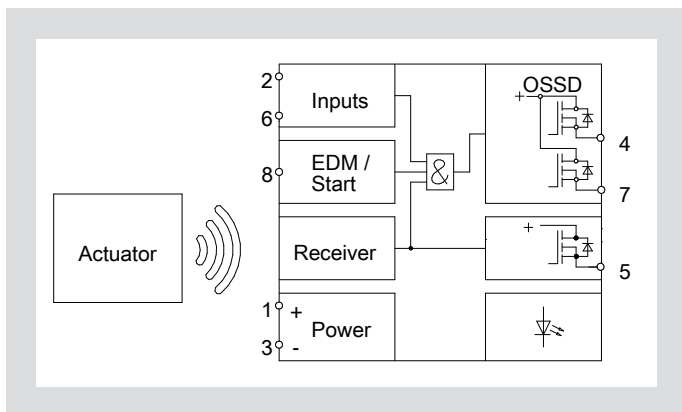

### Pin assignment

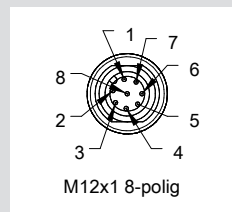

### Connector

PIN	Colour	Function
1	BN	UB
2	WH	Safety input 1
3	BU	GND
4	BK	Safety output 1
5	GY	Diagnostic output
6	PK	Safety input 2
7	VT	Safety output 2
8	OG	EDM-start input

# STS – Non-contact safety switches with coding

## Tailor-made manipulation protection

Different applications require different solutions when it comes to existing manipulation protection.

Safety switches from the STS series have 3 different coding variations, which means that they can always offer the right solution.

### Coded:

The safety switch accepts every STS actuator.

### Fully coded:

The safety switch only accepts the programmed-in STS actuator.

### Unique:

The safety switch only accepts STS actuator delivered with it. An STS actuator cannot be programmed in.

## Diverse installation

The 5 actuation directions of the STS series and the maximum displacement between the actuator and switch element of 8 mm make installation easy even when the protective device to be monitored has large mechanical tolerances.

The resulting advantage is that it can be used universally on removable, rotatable, or sideways-moving protective devices.

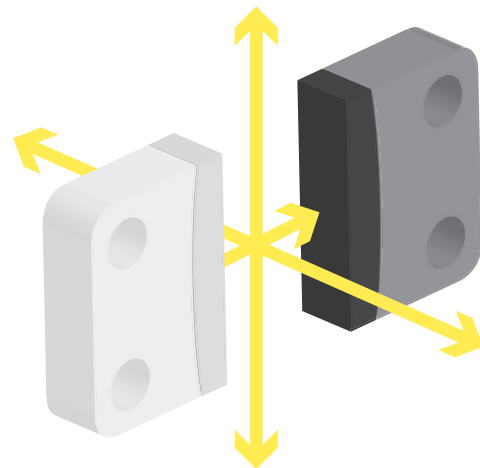

5 different actuation directions for universal use

## Application

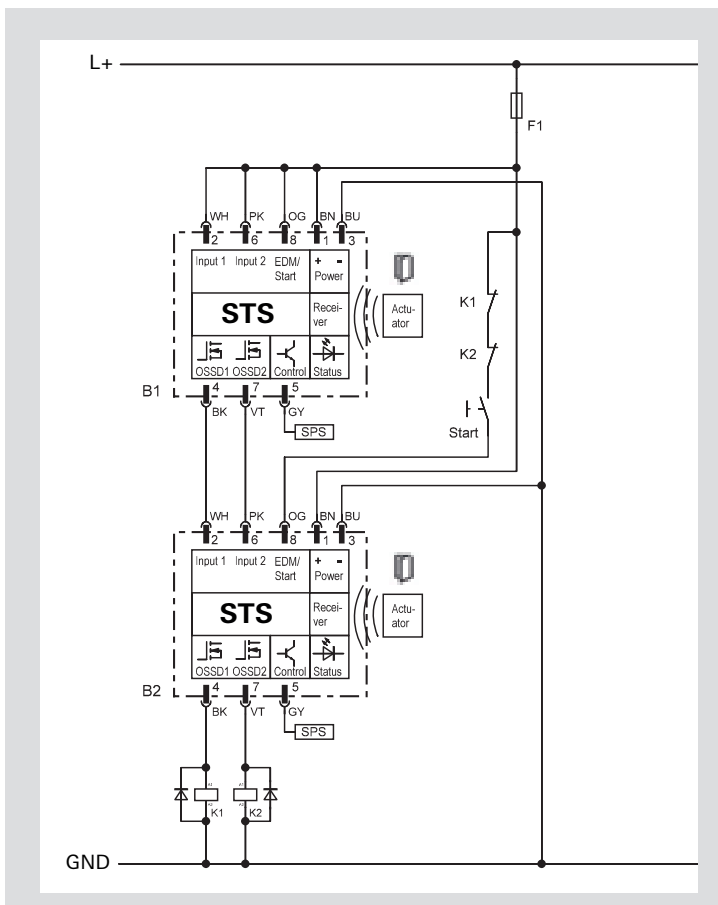

Serial wiring of 2 safety switches STS with manual start and EDM

# STS – Non-contact safety switches with coding

## Circuit diagram

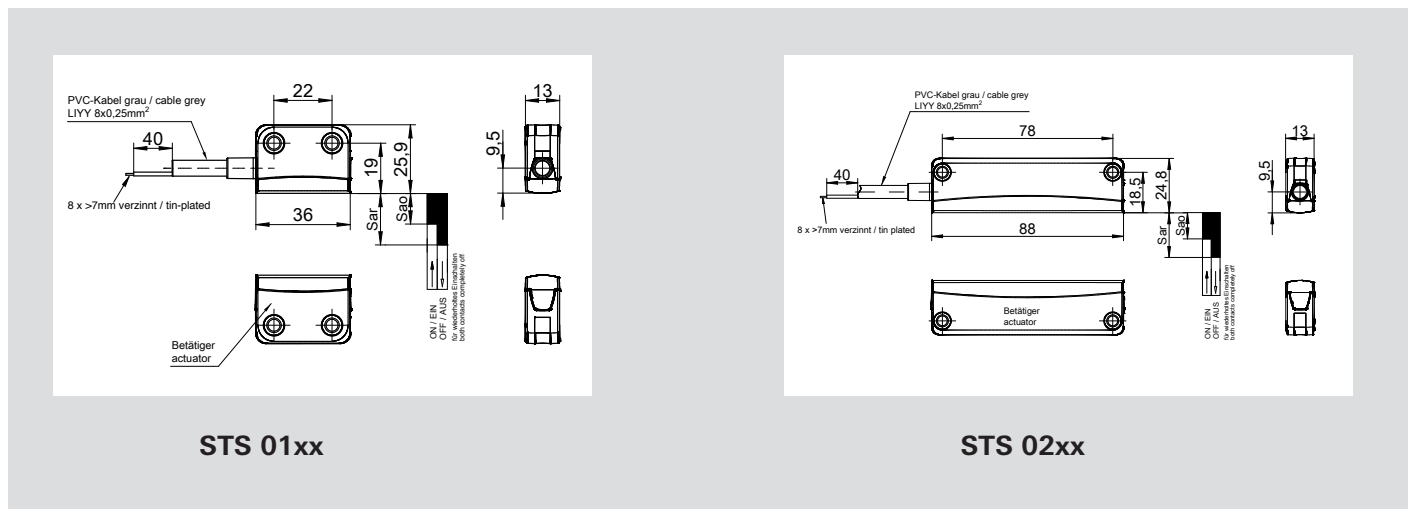

## Technical data

<b>Function</b>	Non-contact safety switch	
Function display	LED, three-colored	
<b>Supply circuit</b>		
Nominal voltage $U_N$	24 V DC	
Operating voltage range $U_B$	0.9 - 1.1 x $U_N$	
Galvanic isolation supply circuit - output circuit	no	
<b>Control circuits</b>		
Number of safety inputs	2	
EDM/start input	1	
Input current, max.	2 mA	
<b>Output circuits</b>		
Number	OSSD	2
	Diagnostics	1
Short-circuit monitoring	yes	
Switching current, max.	OSSD	400 mA
	Diagnostics	50 mA
Switching voltage, max.	$U_B - 0.2 V$	
Series connection	max. 30 sensors	
<b>Switching behavior</b>		
Switching distance / (Sao / Sar)	STS 01xx	8 mm / 18 mm
	STS 02xx	10 mm / 18 mm
Hysteresis	2 mm	
Actuator displacement, max.	8 mm	
Actuation directions	Operator definable	
Switching frequency	3 Hz	
<b>General data</b>		
Creepage distances and clearances between the circuits	EN 60664-1	
Protection class as per EN 60529	IP67	
Operating ambient temperature	-25 °C - +70 °C	
Connection	M12 (8 pole) / cable (8 pole)	
Standards	EN ISO 13849-1, EN 62061	
Certificates / Approvals	TÜV, cULus	

# STS – Non-contact safety switches with coding

## Overview of devices | part numbers

Type	Description	Coding	Part no.	Std. pack
STS 0110	Switch-set, automatic start, connection M12-8	coded	R1.400.0110.0	1
STS 0113	Switch-set, automatic start, connection cable 3m	coded	R1.400.0113.0	1
STS 0114	Switch-set, automatic start, connection cable 5m	coded	R1.400.0114.0	1
STS 0116	Switch-set, automatic start, connection cable 10m	coded	R1.400.0116.0	1
STS 0130	Switch-set, automatic start, connection M12-8	fully-coded	R1.400.0130.0	1
STS 0133	Switch-set, automatic start, connection cable 3m	fully-coded	R1.400.0133.0	1
STS 0134	Switch-set, automatic start, connection cable 5m	fully-coded	R1.400.0134.0	1
STS 0136	Switch-set, automatic start, connection cable 10m	fully-coded	R1.400.0136.0	1
STS 0150	Switch-set, automatic start, connection M12-8	unique	R1.400.0150.0	1
STS 0153	Switch-set, automatic start, connection cable 3m	unique	R1.400.0153.0	1
STS 0154	Switch-set, automatic start, connection cable 5m	unique	R1.400.0154.0	1
STS 0156	Switch-set, automatic start, connection cable 10m	unique	R1.400.0156.0	1
STS 0120	Switch-set, manual start, connection M12-8	coded	R1.400.0120.0	1
STS 0123	Switch-set, manual start, connection cable 3m	coded	R1.400.0123.0	1
STS 0124	Switch-set, manual start, connection cable 5m	coded	R1.400.0124.0	1
STS 0126	Switch-set, manual start, connection cable 10m	coded	R1.400.0126.0	1
STS 0140	Switch-set, manual start, connection M12-8	fully-coded	R1.400.0140.0	1
STS 0143	Switch-set, manual start, connection cable 3m	fully-coded	R1.400.0143.0	1
STS 0144	Switch-set, manual start, connection cable 5m	fully-coded	R1.400.0144.0	1
STS 0146	Switch-set, manual start, connection cable 10m	fully-coded	R1.400.0146.0	1
STS 0160	Switch-set, manual start, connection M12-8	unique	R1.400.0160.0	1
STS 0163	Switch-set, manual start, connection cable 3m	unique	R1.400.0163.0	1
STS 0164	Switch-set, manual start, connection cable 5m	unique	R1.400.0164.0	1
STS 0166	Switch-set, manual start, connection cable 10m	unique	R1.400.0166.0	1
STS 0210	Switch-set, automatic start, connection M12-8	coded	R1.400.0210.0	1
STS 0213	Switch-set, automatic start, connection cable 3m	coded	R1.400.0213.0	1
STS 0214	Switch-set, automatic start, connection cable 5m	coded	R1.400.0214.0	1
STS 0216	Switch-set, automatic start, connection cable 10m	coded	R1.400.0216.0	1
STS 0230	Switch-set, automatic start, connection M12-8	fully-coded	R1.400.0230.0	1
STS 0233	Switch-set, automatic start, connection cable 3m	fully-coded	R1.400.0233.0	1
STS 0234	Switch-set, automatic start, connection cable 5m	fully-coded	R1.400.0234.0	1
STS 0236	Switch-set, automatic start, connection cable 10m	fully-coded	R1.400.0236.0	1
STS 0250	Switch-set, automatic start, connection M12-8	unique	R1.400.0250.0	1
STS 0253	Switch-set, automatic start, connection cable 3m	unique	R1.400.0253.0	1
STS 0254	Switch-set, automatic start, connection cable 5m	unique	R1.400.0254.0	1
STS 0256	Switch-set, automatic start, connection cable 10m	unique	R1.400.0256.0	1
STS 0220	Switch-set, manual start, connection M12-8	coded	R1.400.0220.0	1
STS 0223	Switch-set, manual start, connection cable 3m	coded	R1.400.0223.0	1
STS 0224	Switch-set, manual start, connection cable 5m	coded	R1.400.0224.0	1
STS 0226	Switch-set, manual start, connection cable 10m	coded	R1.400.0226.0	1
STS 0240	Switch-set, manual start, connection M12-8	fully-coded	R1.400.0240.0	1
STS 0243	Switch-set, manual start, connection cable 3m	fully-coded	R1.400.0243.0	1
STS 0244	Switch-set, manual start, connection cable 5m	fully-coded	R1.400.0244.0	1
STS 0246	Switch-set, manual start, connection cable 10m	fully-coded	R1.400.0246.0	1
STS 0260	Switch-set, manual start, connection M12-8	unique	R1.400.0260.0	1
STS 0263	Switch-set, manual start, connection cable 3m	unique	R1.400.0263.0	1
STS 0264	Switch-set, manual start, connection cable 5m	unique	R1.400.0264.0	1
STS 0266	Switch-set, manual start, connection cable 10m	unique	R1.400.0266.0	1
STS 3110	Actuator for STS 011x, 012x, 013x, 014x		R1.400.3110.0	1
STS 3210	Actuator for STS 021x, 022x, 023x, 024x		R1.400.3210.0	1

**Note:** Suitable M12 cables (SLX-CAB) can be selected on P.86

# SMA – Magnetic safety switches



SMA 01xx



## Applications

- Machine and plant manufacturing
- Packing machines
- Wood-processing machines

## Features

- Block-shaped design
- For harsh operating conditions
- Tamper proof
- Can be used up to PL e/Category 4 (EN ISO 13849-1)
- Degree of Protection IP67

## Technical data

Set	SMA 011x	SMA 012x
Dimensions / mm (L x W x H)	36 x 26 x 13 mm	
Actuating distance / (Sao / Sar)	8 / 17 mm	
Directions of actuation	Front - Front / Front - Side / Side - Side	
Protection degree	IP67	
Contact type	Reed	
Contact assignment	NC / NO	NO / NO
Switching voltage	48 V DC	
Switching current	0.2 A	
Maximum cable length	20 m	

## Dimension diagram

SMA 011x / SMA 012x

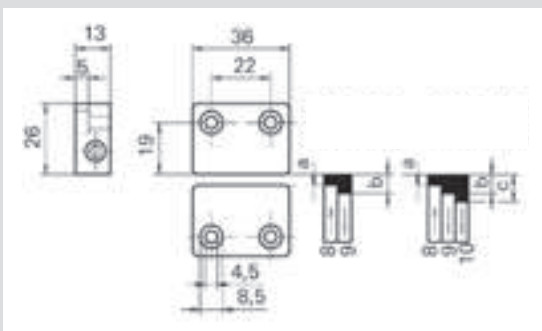

## Circuit diagram

SMA 011x

SMA 012x

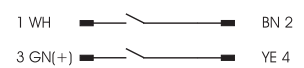
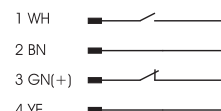

Contacts are shown in non-operated state (magnet is out of actuating distance Sar)

# SMA – Magnetic safety switches



## Applications

- Machine and plant manufacturing
- Packing machines
- Wood-processing machines

## Features

- Rectangle-shaped design
- For harsh operating conditions
- Tamper proof
- Can be used up to PL e/Category 4 (EN ISO 13849-1)
- Degree of Protection IP67

SMA 02xx  
SMA 06xx



## Technical data

Set	SMA 021x	SMA 022x	SMA 023x/024x	SMA 061x	SMA 062x
Dimensions / mm (L x W x H)	88 x 25 x 14 mm				
Actuating distance / (Sao / Sar)	7 / 17 mm	7 / 18 mm	7 / 22 mm	4 / 16 mm	4 / 17 mm
Directions of actuation	Front - Front / Front - Side / Side - Side				
Protection degree	IP67				
Contact type	Reed				
Contact assignment	NC / NO	NO / NO	NO / NO / NC	NC / NO	NO / NO
Switching voltage	48 V DC				
Switching current	0.2 A				
Maximum cable length	20 m				

sensor PRO

## Dimension diagram

SMA 021x/ SMA 022x/SMA 023x/SMA 024x

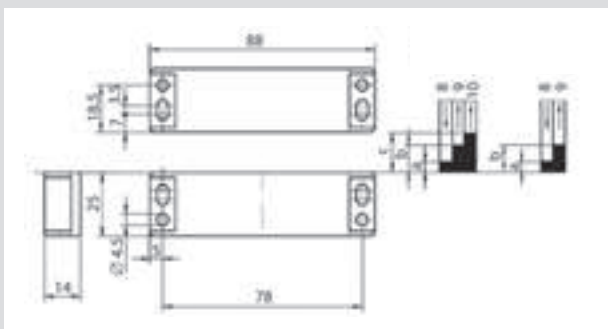

## Circuit diagram

SMA 021x / SMA 0219

SMA 022x / SMA 0229

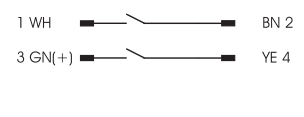
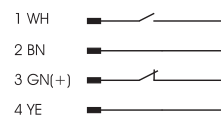

SMA 023x

SMA 024x (with LED)

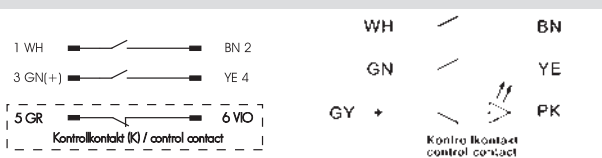

Contacts are shown in non-operated state (magnet is out of actuating distance Sar)



**Overview of devices | part numbers**

Type	Description	Contact	Part no.	Std. pack
SMA 0113	Switch-set with cable 3 m + magnet	NC / NO	R1.100.0113.0	1
SMA 0123	Switch-set with cable 3 m + magnet	NO / NO	R1.100.0123.0	1
SMA 0119	Switch-set mit with M8 connection + magnet	NC / NO	R1.100.0119.0	1
SMA 0129	Switch-set mit with M8 connection + magnet	NO / NO	R1.100.0129.0	1
SMA 0213	Switch-set with cable 3 m + magnet	NC / NO	R1.100.0213.0	1
SMA 0223	Switch-set with cable 3 m + magnet	NO / NO	R1.100.0223.0	1
SMA 0224	Switch-set with cable 5 m + magnet	NO / NO	R1.100.0224.0	1
SMA 0226	Switch-set with cable 10 m + magnet	NO / NO	R1.100.0226.0	1
SMA 0228	Switch-set with cable 20 m + magnet	NO / NO	R1.100.0228.0	1
SMA 0233	Switch-set with cable 3 m + magnet	NO / NO / NC	R1.100.0233.0	1
SMA 0243	Switch-set with cable 3 m, LED + magnet	NO / NO / NC	R1.100.0243.0	1
SMA 0249	Switch-set with M12 connection, LED + magnet	NO / NO / NC	R1.100.0249.0	1
SMA 0219	Switch-set with M8 connection + magnet	NC / NO	R1.100.0219.0	1
SMA 0229	Switch-set with M8 connection + magnet	NO / NO	R1.100.0229.0	1
SMA 0313	Switch-set with cable 3 m + magnet	NC / NO	R1.100.0313.0	1
SMA 0323	Switch-set with cable 3 m + magnet	NO / NO	R1.100.0323.0	1
SMA 0319	Switch-set with M8 connection + magnet	NC / NO	R1.100.0319.0	1
SMA 0329	Switch-set with M8 connection + magnet	NO / NO	R1.100.0329.0	1
SMA 0613	Switch-set with cable 3 m + magnet	NC / NO	R1.100.0613.0	1
SMA 0623	Switch-set with cable 3 m + magnet	NO / NO	R1.100.0623.0	1
SMA 0626	Switch-set with cable 10 m + magnet	NO / NO	R1.100.0626.0	1
SMA 0619	Switch-set with M8 + magnet	NC / NO	R1.100.0619.0	1
SMA 0629	Switch-set with M8 + magnet	NO / NO	R1.100.0629.0	1

**Accessories for SMA**



**sensor** PRO

**Overview of devices | part numbers**

Type	Description	Contact	Part no.	Std. pack
SMA 3110	Magnet (NC / NO) for SMA 011x		R1.100.3110.0	5
SMA 3120	Magnet (NO / NO) for SMA 012x		R1.100.3120.0	5
SMA 3200	Magnet for SMA 02xx		R1.100.3200.0	5
SMA 3300	Magnet for SMA 03xx		R1.100.3300.0	5
SMA 3600	Magnet for SMA 06xx		R1.100.3600.0	5
SMA 4100	Washer for SMA 01xx		R1.100.4100.0	10
SMA 4200	Washer for SMA 02xx / SMA 06xx		R1.100.4200.0	10
SMA 5004	Cable, 5 m		R1.100.5004.0	1
SMA 5005	Cable, 10 m		R1.100.5005.0	1

**Note:** Suitable M12 cables (SLX-CAB) can be selected on P.86

# SMI 1001 – Magnetic switch interface



## Applications

- Connecting in series of two-channel sensors with contact assignment NO/NO up to PL d/Categorie 3 (EN ISO 13849-1)

## Features

- Control via a maximum of 4 two-channel sensors
- Signal output for each sensor
- Optical indication of the switching state of each sensor

## Function

The SMI 1001 connects safety switches / position switches in series. Several safety switches or position switches can be connected to **safe** RELAY safety switching devices or to **samos**<sup>®</sup> and **samos**<sup>®</sup>PRO safety systems and evaluated.

The SMI 1001 features status displays for the switching state of the NO circuits of the connected sensors as well as four diagnostics outputs for the display of the switching state of the NO circuits via external LEDs or a control.

## Dimension diagram

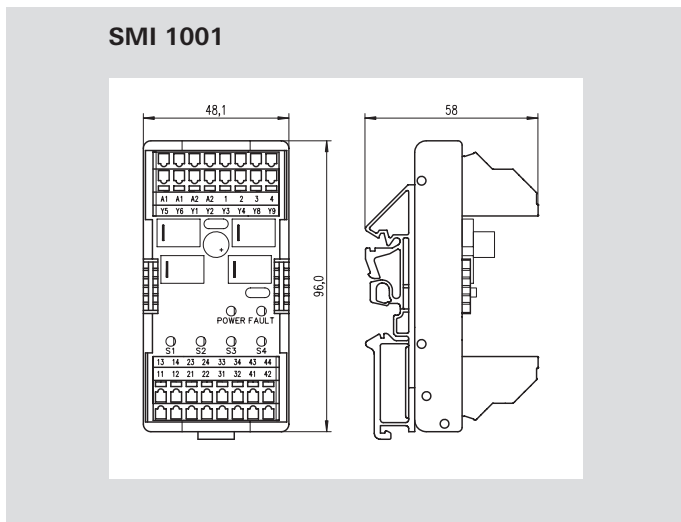

## Circuit diagram

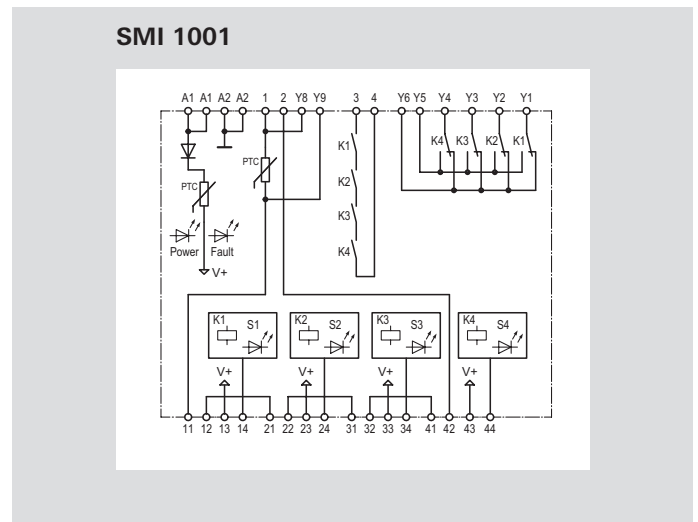

# SMI 1001 – Magnetic switch interface

## Overview of devices | part numbers

Type	Rated voltage	Terminals	Part no.	Std. pack
SMI 1001	24 V DC	Push-in terminals, fixed	R1.100.4001.0	1

## Technical data

Function	
Function display	1 x LEDs green, 5 x LEDs red
Power supply circuit	
Rated voltage	24 V DC
Rated consumption	1.5 W
Control circuit 11 – 44	
Max. cable length	30 m
Output circuit signal outputs Y1 – Y6	
Contact type	NO
Rated switching voltage	24 V DC
Max. switching current	0.5 A
Output circuit 1, 2, 3, 4	
Contact type	NO
Rated switching voltage	24 V DC
Max. switching current	150 mA
General data	
Creepage distances and clearances	according to EN 60664-1
Ambient temperature/ storage temperature	-25 – +55 °C / -25 – +70 °C
Wire ranges fine-stranded/ solid	0.08 – 2.5 mm <sup>2</sup>
or fine-stranded with ferrules	0.08 – 1 mm <sup>2</sup>
or fine-stranded with TWIN-ferrule	0.08 – 1.5 mm <sup>2</sup>
Weight	0.1 kg
Approvals	cULus

## Application

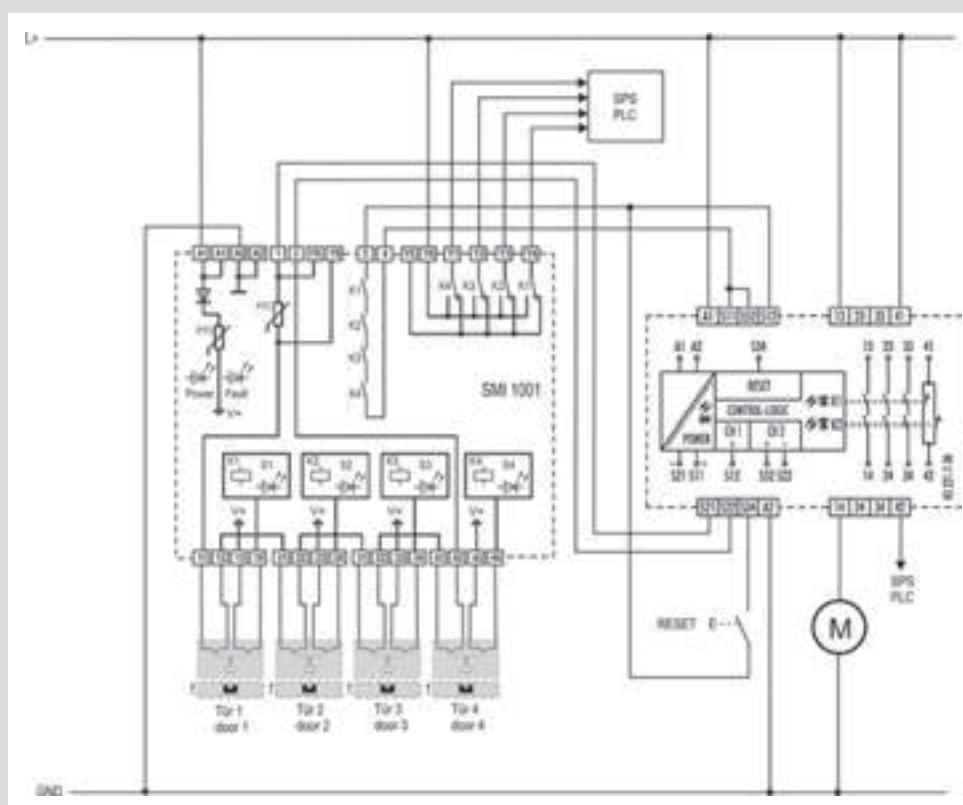

Build your machines in modular fashion  
with flexibility – and safely as well!



**Flexibility and plug-in ease**

Save time and money thanks to flexibility, modular design, and plug-in ease - across all life phases of the machine.

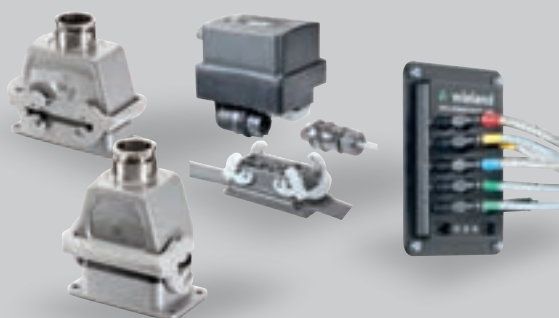



### Safety

Make your machine safe - with solutions from Wieland.

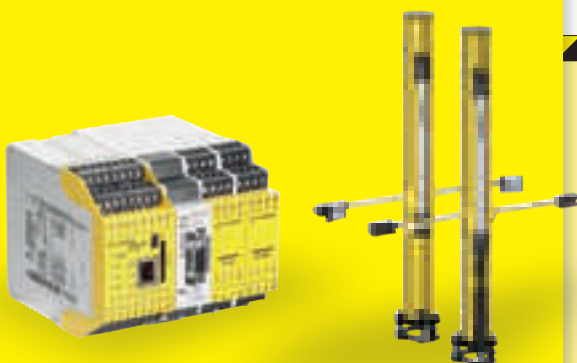

### Process reliability + communication

Increase process reliability and communicate with your machines worldwide.



## Software

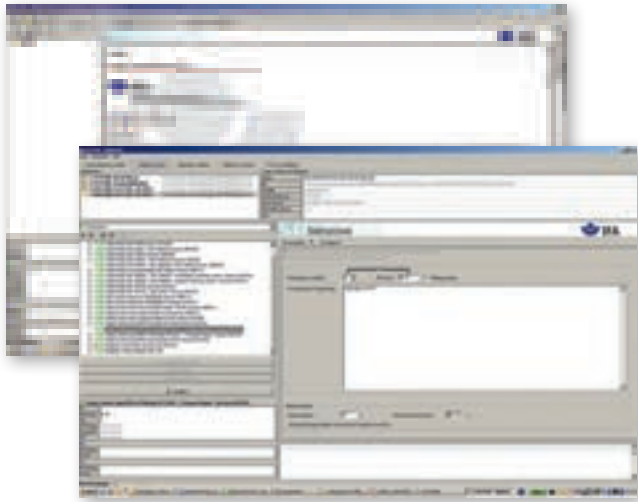

### SISTEMA – safety of machine controls

The SISTEMA software provides developers and testers of safety-related machine controls with comprehensive support when assessing safety within the scope of **DIN EN ISO 13849-1**. The name **SISTEMA** comes from the German "**S**icherheit von **ST**eueringen an **MA**schinen" (safety of machine controls). The tool allows you to reproduce the structure of the safety-related control elements on the basis of the intended architectures and then enables an automated calculation of the reliability values at various levels of detail, including the performance level (PL) attained.

### EPLAN – support during configuration

Support of automation projects naturally also includes EPLAN data and macros which can be very easily downloaded from the Wieland homepage at [www.wieland-electric.com](http://www.wieland-electric.com)



**ePLAN®**

## Training



Wieland Electric offers a range of workshops about the topic of machine safety.

The training covers hazard and risk analysis, definition of the necessary safety functions using the SISTEMA tool and support for selecting and implementing the necessary technical safety measures.

We provide our safety workshops and product training sessions both as in-house training and as a workshop at our modern Sales Center in Bamberg.

- Risk assessment and risk reduction in accordance with EN 12100
- Definition of technical safety measures
- Assessment of safety functions (SISTEMA)
- Product training
- Training for **samos**<sup>®</sup>PLAN 5+

Simply contact us at +49 951 9324 999 or via e-mail at [safety@wieland-electric.com](mailto:safety@wieland-electric.com)

You can get the free programming tool **samos**<sup>®</sup>PLAN 5+ at [www.wieland-electric.com](http://www.wieland-electric.com)  
Service / Software



Sales Center  
in Bamberg



## Technical consultation and general information

### Hotline – one call is all it takes

#### Industrial Automation – Electromechanical

Hotline **+49 951 9324-991**  
E-Mail **AT.TS@wieland-electric.com**

#### Building and Installation Technology

Hotline **+49 951 9324-996**  
E-Mail **BIT.TS@wieland-electric.com**

#### Industrial Automation – Electronics

Hotline **+49 951 9324-995**  
E-Mail **AT.TS@wieland-electric.com**

#### Safety Technology

Hotline **+49 951 9324-999**  
E-Mail **safety@wieland-electric.com**



**General information and news:**  
[www.wieland-electric.com](http://www.wieland-electric.com)

**Visit our e-catalog at**  
<http://eshop.wieland-electric.com>

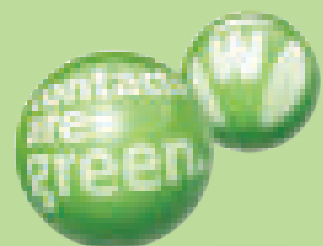

## Our subsidiaries

... and the addresses of our sales partner worldwide are available at:

[www.wieland-electric.com](http://www.wieland-electric.com)



**USA**  
**Wieland Electric Inc.**  
**North American Headquarters**  
 2889 Brighton Road  
 Oakville, Ontario L6H 6C9  
 Phone +1 905 8298414  
 Fax +1 905 8298413  
[www.wielandinc.com](http://www.wielandinc.com)



**CANADA**  
**Wieland Electric Inc.**  
**North American Headquarters**  
 2889 Brighton Road  
 Oakville, Ontario L6H 6C9  
 Phone +1 905 8298414  
 Fax +1 905 8298413  
[www.wieland-electric.ca](http://www.wieland-electric.ca)



**GREAT BRITAIN**  
**Wieland Electric Ltd.**  
 Riverside Business Center,  
 Walnut Tree Close  
 GB-Guildford/Surrey GU1 4UG  
 Phone +44 1483 531213  
 Fax +44 1483 505029  
[sales.uk@wieland-electric.com](mailto:sales.uk@wieland-electric.com)  
[www.wieland.co.uk](http://www.wieland.co.uk)



**FRANCE**  
**Wieland Electric S.A.R.L.**  
 Le Cérame, Hall 6  
 47, avenue des Genottes  
 CS 48313  
 95803 Cergy-Pontoise Cedex  
 Phone +33 1 30320707  
 Fax +33 1 30320714  
[info.france@wieland-electric.com](mailto:info.france@wieland-electric.com)  
[www.wieland-electric.fr](http://www.wieland-electric.fr)



**SPAIN**  
**Wieland Electric S.L.**  
 C/ Maria Auxiliadora 2, bajos  
 E-08017 Barcelona  
 Phone +34 93 2523820  
 Fax +34 93 2523825  
[ventas@wieland-electric.com](mailto:ventas@wieland-electric.com)  
[www.wieland-electric.es](http://www.wieland-electric.es)



**ITALY**  
**Wieland Electric S.r.l.**  
 Via Edison, 209  
 I-20019 Settimo Milanese  
 Phone +39 02 48916357  
 Fax +39 02 48920685  
[info.italy@wieland-electric.com](mailto:info.italy@wieland-electric.com)  
[www.wieland-electric.it](http://www.wieland-electric.it)



**BELGIUM & GD LUXEMBOURG**  
**ATEM-Wieland Electric NV**  
 Bedrijvenpark De Veert 4  
 B-2830 Willebroek  
 Phone +32 3 8661800  
 Fax +32 3 8661828  
[info.belgium@wieland-electric.com](mailto:info.belgium@wieland-electric.com)  
[www.wieland-electric.be](http://www.wieland-electric.be)



**DENMARK**  
**Wieland Electric A/S**  
 Vallørækken 26  
 DK-4600 Køge  
 Phone +45 70 266635  
 Fax +45 70 266637  
[sales.denmark@wieland-electric.com](mailto:sales.denmark@wieland-electric.com)  
[www.wieland-electric.dk](http://www.wieland-electric.dk)



**SWITZERLAND**  
**Wieland Electric AG**  
 Harzachstrasse 2b  
 CH-8404 Winterthur  
 Phone +41 52 2352100  
 Fax +41 52 2352119  
[info.swiss@wieland-electric.com](mailto:info.swiss@wieland-electric.com)  
[www.wieland-electric.ch](http://www.wieland-electric.ch)



**POLAND**  
**Wieland Electric Sp. Zo.o.**  
 Św. Antoniego 8  
 62-080 Swadzim  
 Phone +48 61 2225400  
 Fax +48 61 8407166  
[office@wieland-electric.pl](mailto:office@wieland-electric.pl)  
[www.wieland-electric.pl](http://www.wieland-electric.pl)



**CHINA**  
**Wieland Electric Trading**  
 Unit 2703 International Soho City  
 889 Renmin Road,  
 Huang Pu District  
 PRC- Shanghai 200010  
 Phone +86 21 63555833  
 Fax +86 21 63550090  
[info-shanghai@wieland-electric.com](mailto:info-shanghai@wieland-electric.com)  
[www.wieland-electric.cn](http://www.wieland-electric.cn)









































**JAPAN**  
**Wieland Electric Co, Ltd.**  
 Nisso No. 16 Bldg. 7F  
 3-8-8 Shin-Yokohama,  
 Kohoku-ku  
 Yokohama 222-0033  
 Phone +81 45 473 5085  
 Fax +81 45 470 5408  
[info.japan@wieland-electric.com](mailto:info.japan@wieland-electric.com)



**GERMANY**  
**Headquarters**  
**Wieland Electric GmbH**  
 Brennerstraße 10 – 14  
 96052 Bamberg, Germany  
 Phone +49 951 9324-0  
 Fax +49 951 9324-198  
[info@wieland-electric.com](mailto:info@wieland-electric.com)  
[www.wieland-electric.de](http://www.wieland-electric.de)

Subject to technical modifications! **gesis**®, **RST**®, **GST**®, **GST18**®, **podis**®, **samos**® and **saris**® are registered trademarks of Wieland Electric GmbH

# Glossary

	<b>Emergency stop monitoring</b> Floating contacts		<b>Single-channel input circuit</b> 1 NC contact or semiconducto
	<b>Protective gate monitoring</b> Floating contacts		<b>Two-channel input circuit</b> 2 NC contacts or semiconductors
	<b>Position monitoring</b> Magnetic switch		<b>Two-channel input circuit, antivalent</b> 1 NO / 1 NC contacts or semiconductors
	<b>Safety light grid / -light curtain</b> acc. to EN 61496 BWS Type 4 / Type 2		<b>Cross monitoring</b> between two input circuits
	<b>Two-hand control</b> according to EN 574		<b>Synchro-check</b> between two input circuits
	<b>Controlled Stop</b> according to EN 60204-1 stop category 1		<b>Safe Start</b> Start command is accepted only when the input circuits are closed
	<b>Standstill and motion monitoring</b>		<b>Combi-reset</b> Automatic start possible after voltage failure, based on the risk analysis
	<b>Safety shut-off mat monitoring</b> (4-wire principle, short-circuiting)		<b>Automatic Reset</b> after application of the voltage and/or after safety request
	<b>Valve position monitoring</b>		<b>Manual Reset</b> in the case of a rising edge at the reset input
	<b>Contact expansion</b>		<b>Reset button monitoring</b> in the case of a falling edge at the reset input
	<b>Machine building industry</b>		<b>Contacts (NO/NC)</b> safe semiconductor outputs
	<b>Elevator systems</b> in accord. with EN 81-1		<b>Alarm contacts</b>
	<b>Combustion plants</b> according to EN 50156-1		<b>Safe changeover contacts</b>
	<b>Process technology</b> according to IEC 61511		<b>Safe semi conductor outputs</b>
	<b>Finger protection</b>		<b>Safe OFF-delay</b>
	<b>Hand protection</b>		<b>Safe ON-delay</b>
	<b>Arm protection</b>		<b>Monoflop</b> for rapid tactile applications
	<b>Access protection</b>		<b>Reset of time lapse</b> for OFF-delayed contacts
	<b>Personal protection</b>		<b>Expanded diagnostics</b>

# Selection of our catalogs



**0670.1 gesis®**  
Pluggable electrical installation  
for indoors



**0700.1 gesis® ELECTRONIC**  
Decentralized building  
automation with plug & play

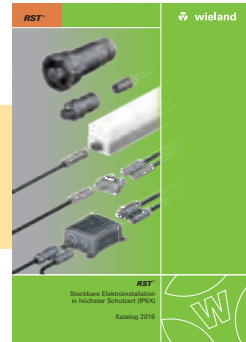

**0690.1 RST®**  
Pluggable Electrical Installation  
in highest protection (IP6X)



**0500.1 selos/fasis** – DIN rail terminal  
blocks with screw, tension spring and  
push-in connection



**0530.1 revos**  
Industrial Multipole  
Connectors

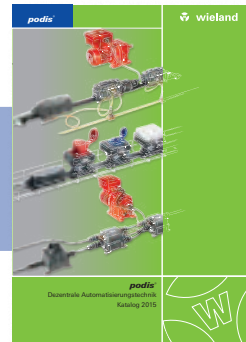

**0830.1 podis®**  
Decentralized  
Automation



**0415.1 Machine building**  
Individual customer solutions



**0416.1 Lift Technology**  
Solutions for the electrical installation



**0430.1 Wind power**  
Electro-technical solutions  
for wind energy systems

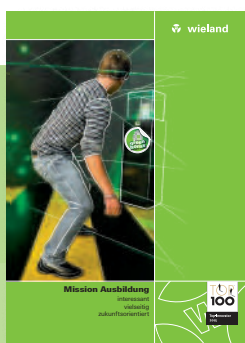

**0912.0 Mission Ausbildung**

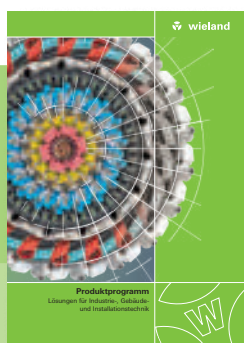

**0901.1 Product Range**  
Solutions for industrial, building  
and installation technology

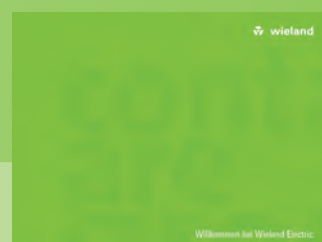

**0950.1 Wieland Image brochure**



Headquarters:  
Wieland Electric GmbH  
Brennerstraße 10 – 14  
96052 Bamberg, Germany

Phone +49 951 9324-0  
Fax +49 951 9324-198  
info@wieland-electric.com  
www.wieland-electric.com

## Industrial technology

### Solutions for the control cabinet

- DIN rail terminal blocks
  - Screw, tension spring or push-in connection technology
  - Wire cross sections up to 300 mm<sup>2</sup>
  - Numerous special functions
  - Software solutions interfacing to CAE systems
- Safety
  - Safe signal acquisition
  - Safety switching devices
  - Modular safety modules
  - Compact safety controllers
  - Application consulting and training
- Network engineering and fieldbus systems
  - Remote maintenance via VPN industrial router and VPN service portal
  - Industrial Ethernet switches
  - PLC and I/O systems, standard and increased environmental conditions
- Interface
  - Power supply units
  - Overvoltage protection
  - Coupling relays, semiconductor switches
  - Timer relays, measuring and monitoring relays
  - Analog coupling and converter modules
  - Passive interfaces

### Solutions for field applications

- Decentralized installation and automation technology
  - Electrical installation for wind tower
  - Fieldbus interfaces and motor starters
- Connectors for industrial applications
  - Rectangular and round connectors
  - Aluminium or plastic housings
  - Degree of protection up to IP69K
  - Current-carrying capacity up to 100 A
  - Connectors for hazardous areas
  - Modular, application-specific technology

### PC board terminals and connectors

- Screw or spring clamp connection technology
- Spacings: 3.5 mm to 10.16 mm
- Reflow or wave soldering process

## Building and installation technology

- Building installation systems
  - Main power supply connectors IP 20/IP 65 ... IP 69K
  - Bus connectors
  - Low-voltage connectors
  - Power distribution system with flat cables
  - Distribution systems
  - Room automation with KNX, EnOcean, SMI and DALI
  - DIN rail terminal blocks for electrical installations
  - Overvoltage protection

# contacts are green.