

YASKAWA

MACHINE CONTROLLER MP2000 SERIES

Machine Controller Line-up



Certified for
ISO9001 and
ISO14001



JQA-0422



JQA-EM0202



MECHATROLINK

Providing Solid Support to Systems Development

The MP2000 Series Machine Controller

The MP2000 Series Machine Controller has been developed to optimize control of machines. It has surpassed the top achievements of PLCs and user-developed controllers to offer ideal motion control.

- Feature 1** (Orange): Reduces System Tact Time
High-speed Multi-axis Control ▶ P4
- Feature 2** (Green): Enables Ideal Machine Motion and Synchronization
High-level Synchronization ▶ P6
- Feature 3** (Blue): Systems Engineering with a Single Tool
High Operability ▶ P8
- Feature 4** (Red): Optimizes System Configuration
Highly Expandable ▶ P14
- Feature 5** (Yellow): Optimizes Configuration of Motion Control System
Optimal Positioning ▶ P16

One Solution to All of Your Machine Control Problems!

Machine Controller and PLC (Programmable Logic Controller) : How do They Differ ?

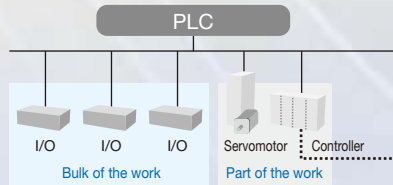

- ◎ Excellent at controlling I/O.
- ◎ Focuses more on connectability to various I/O devices than axes synchronization.
- ◎ Most are modules.

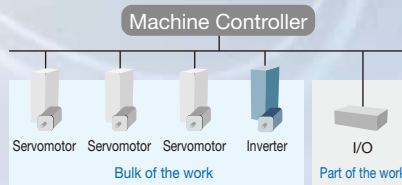

- ◎ Ideal for controlling machines and devices.
- ◎ Focuses on precise synchronous and high-speed control on multiple motors.
- ◎ The optimal controller models can be selected based on the device requirements.

MP2000 Series

The MP2000 Series Brings a Cornucopia of Solutions The MP2000 Series Fully Supports Various Applications

Gantry Mechanism and Alignment Stage Mechanism

These mechanisms comprise the basic system used in devices for the manufacturing and the inspection of semi-conductor chips, LCDs, and other components. High precision as well as high acceleration and deceleration are required for these processes. Two axes must be synchronized to control and operate the gantry mechanism.

Advantage Achieves complete synchronous multi-axis control and online adjustment.



Solution for Conveyance

Provides a solution for the control mechanism that allows workpieces to be processed in accordance with the speed of the production line.

Advantage Allows the slave axes to follow master axis operation when the inverter is used as the master axis and both the inverter and servo drives are connected through a network.



Solution for Winder

Provides a solution for the control mechanism where a winder winds and a feeder unwinds.

Advantage Achieves high-precision winding, feeding, dancer control, and tension control with standard servo drives and inverters. Line control can be constructed easily with user functions set in advance.





MP2000 Series Machine Controller: The Ideal Machine Control Tool

Various types of controllers are available to meet the needs of your machines. PLCs in general are usually in a modular form, but Yaskawa's MP2000 Series Machine Controllers come in a variety of forms, including board type and panel type. This allows you to select the ideal controller for your system.



Board Type

Board Type Machine Controller MP2100

- ▶ **Perfect for machines connected to a personal computer**
 - No additional power supply is required as it can be installed on a personal computer.
 - Runs on the same applications as others in the MP2000 Series
 - Motion APIs enable coordination with your personal computer.

Module Type Machine Controller MP2200

- ▶ **The ideal machine controller for large-scale systems requiring sophisticated multi-axis controls and reduction of tact time**
 - The flagship of high-performance MP2000 Series Machine Controllers
 - Synchronous control of up to 256 axes
 - As many as 35 slots can be added for option modules.



Module Type

All-in-one Type Machine Controller MP2300/MP2310/MP2300S



- ▶ **The optimal controller for systems requiring high cost performance for various simple motion controls, from positioning and interpolation to sophisticated multi-axis control.**
 - The power supply, CPU, 16-axis motion control function, and network (Ethernet communications for MP2310 and MP2300S) are all integrated.
 - Slots for optional modules allow the expansion of I/Os and network systems.
 - Up to 64 axes can be controlled.

All-in-one Type

Compact Unit Type Machine Controller MP2400

- ▶ **The optimal machine controller for small-scale systems for simple motion controls such as positioning and interpolation**
 - The power supply, CPU, 16-axis motion control function, and Ethernet communications are all integrated.
 - A stand-alone system that reduces space and wiring requirements can be constructed.



Compact Unit Type

Panel Type Machine Controller MP2500



- ▶ **The perfect machine controller for systems that need to be compact but must also provide plenty of data**
 - Runs on the same application programs as others in the MP2000 Series
 - The HMI and personal computer functions are all integrated in this all-in-one controller.

Panel Type

CONTENTS

Features	High-speed Multi-axis Control	4
	High-level Synchronization	6
	High Operability	8
	Highly Expandable	14
	Optimal Positioning	16
	A Variety of Support Tools	18
Series Features	MP2100(M), MP2101(M), MP2101T(M)	20
	MP2200	22
	MP2300, MP2310, MP2300S	24
	MP2400	25
	MP2500/M/B/MB	26
Related Information	More about the MP2000 Series	28
	Related Products	29
	Third-party MECHATROLINK-compliant Devices	31
	Other Modules / Terminals	33
	Reconfiguring Systems with the MP2000	35
Specifications	System Configurations	37
	Hardware Specifications	40
	Software Specifications	66
AC Servo Drives		74
Ordering Reference		82
Quick Reference		88
Read Before Ordering		94
Full Support		95





Reduces System Tact Time

High-speed Multi-axis Control

Maximizes Speed with Accurate Motion Control

High speed processing and network communications are vital to maximizing the output of intricate systems. The high-speed CPU of the MP2000 Series reduces the execution time needed for commands. Better yet, with the MECHATROLINK-II motion network (transmission speed: 10 Mbps) and MECHATROLINK-III (transmission speed: 100 Mbps) used in the MP2000 Series, high-accuracy and high-speed motion control on multiple axes is realized.

Highest-speed Machine Controller on the Market

Integration of the open motion network MECHATROLINK-III enables high-speed motion control. (When the SVC-01 motion control module is installed.)











	MECHATROLINK-II	MECHATROLINK-III														
 <p>Maximum transmission cycles 125 μs</p>	<table border="1"> <thead> <tr> <th>Transmission Speed</th> <th>Transmission Cycles (Number of Connected Stations)</th> </tr> </thead> <tbody> <tr> <td rowspan="4">10 Mbps</td> <td>0.5 ms (4 stations)</td> </tr> <tr> <td>1.0 ms (9 stations)</td> </tr> <tr> <td>1.5 ms (15 stations)</td> </tr> <tr> <td>2.0 ms (16 stations)*1</td> </tr> </tbody> </table>	Transmission Speed	Transmission Cycles (Number of Connected Stations)	10 Mbps	0.5 ms (4 stations)	1.0 ms (9 stations)	1.5 ms (15 stations)	2.0 ms (16 stations)*1	<table border="1"> <thead> <tr> <th>Transmission Speed</th> <th>Transmission Cycles (Number of Connected Stations)</th> </tr> </thead> <tbody> <tr> <td rowspan="4">100 Mbps</td> <td>125 μs (4 stations)</td> </tr> <tr> <td>250 μs (8 stations)</td> </tr> <tr> <td>500 μs (14 stations)</td> </tr> <tr> <td>1.0 ms (16 stations)*1</td> </tr> </tbody> </table>	Transmission Speed	Transmission Cycles (Number of Connected Stations)	100 Mbps	125 μs (4 stations)	250 μs (8 stations)	500 μs (14 stations)	1.0 ms (16 stations)*1
Transmission Speed	Transmission Cycles (Number of Connected Stations)															
10 Mbps	0.5 ms (4 stations)															
	1.0 ms (9 stations)															
	1.5 ms (15 stations)															
	2.0 ms (16 stations)*1															
Transmission Speed	Transmission Cycles (Number of Connected Stations)															
100 Mbps	125 μs (4 stations)															
	250 μs (8 stations)															
	500 μs (14 stations)															
	1.0 ms (16 stations)*1															

*1 : The maximum number of stations, including I/O, is 21.

A Variety of Controller Models with up to 256-axis Synchronous Control

The optimal system configuration can be selected from a variety of controllers, including module, all-in-one, compact unit, board, and panel-integrated models. Servo drives for up to 256 axes can be synchronously controlled.



	Module Type	All-in-one Type			Compact Unit Type	Board Type		Panel-integrated Type, Panel-separated Type	
	MP2200	MP2300	MP2310	MP2300S	MP2400	MP2100, MP2101(T)	MP2100M, MP2101(T)M	MP2500, MP2500M, MP2500B	MP2500MB
Max. Number of Axes	256 axes	48 axes*2	64 axes*2	32 axes*2	16 axes	16 axes	32 axes	16 axes	32 axes
CPU	CPU selection*3	Integrated CPU				Built-in CPU			
									

*2 : The number of axes refers to the number of servomotor control axes that can be connected to MECHATROLINK-III.
*3 : Can be selected from CPU-01, -02, -03, and -04.

Four Different Control Modes to Select from. They can be Switched between while On-line, and for Each Transmission Cycle



A MECHATROLINK motion network is used with the MP2000 Series Machine Controller for control of an adaptive and highly precise servo drive.

In addition to torque, position, and speed control modes, the MECHATROLINK network also supports phase control mode, which delivers particularly high accuracy.

The various control modes can be switched on-the-fly for perfect control of even the most complex applications.

All-in-one Four Control Modes

● Synchronous Phase Control

Speed control with position compensation (electronic shaft) or position control with 100% speed feed forward (electronic cam). Multi-axis servomotors can be controlled synchronously.

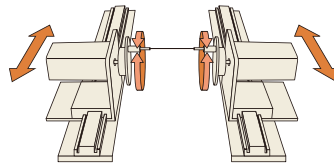

0.3mm dia. mechanical pencil lead does not break.

● Torque Control

Generates a constant torque, regardless of speed.

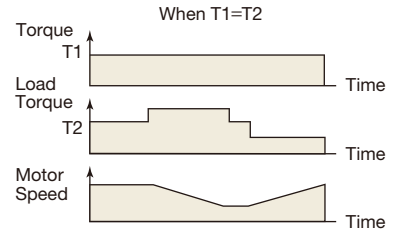

● Position Control

Advances to the target position, and stops or holds.

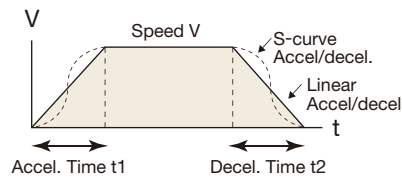

● Speed Control

Turns the motor at the specified speed, with user-defined acceleration/deceleration slopes.

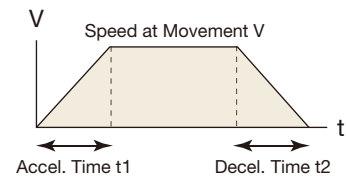

Online Switching Control Modes

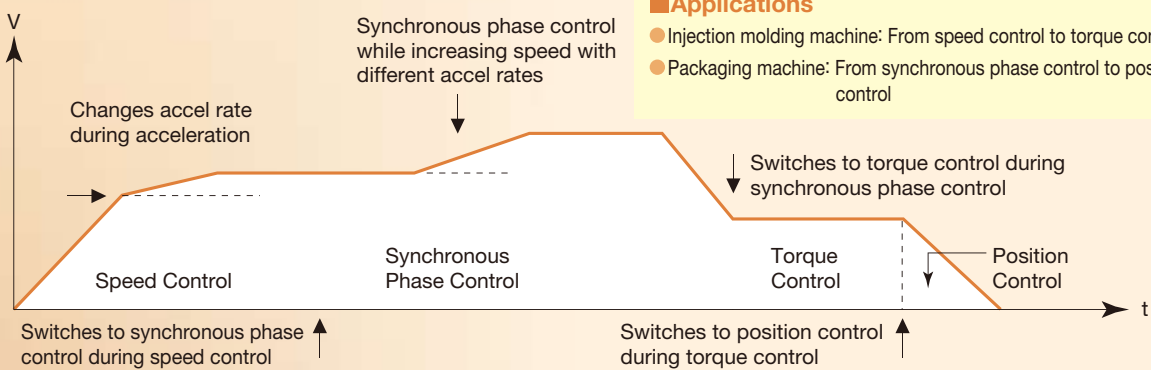

Interpolation Functions for Simple Programming

Commands for linear, circular, and helical interpolation are available for easy programming of machine motions.

● **Linear Interpolation, Circular Interpolation**
Basic motions, such as rapid traverse positioning, linear interpolation, and circular interpolation, can be easily programmed.

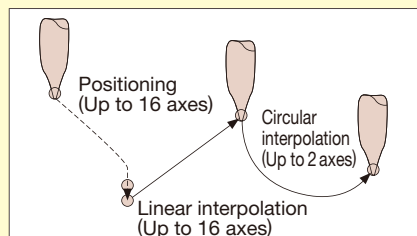

● **Helical Interpolation**

Helical interpolation can be programmed to combine linear and circular interpolation (Fig. A). Helical interpolation can also be used by applying linear interpolation portion to the rotary axis to trace an arc using normal line control (Fig. B).

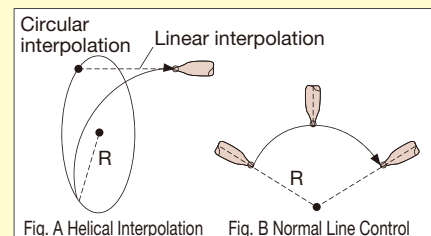



Enables Ideal Machine Motion and Synchronization

High-level Synchronization

Perfect Synchronization can Deliver Perfect Operations

Excellent synchronization of the controller is important in applications that require synchronous control on multiple axes.

The MP2000 Series can meet such requirements in various applications and remarkably improve machine precision.

MP2000 Series for Complete Synchronous Control through a Network



In addition to synchronous control on 32 axes using an SVA-01 analog motion control module, the MP2000 Series is capable of synchronous control between SVB-01 and SVC-01 modules. Because of such high-level synchronization, the MP2000 Series can be used for fully synchronous control of servo drives up to 256 axes (MP2200) connected by MECHATROLINK-II or III and thus, opens another field of applications.

Perfect Synchronization with No Delay

General controllers are designed mainly to control I/Os, whereas machine controllers are developed as an ideal tool to control systems. All functions required for motion control are designed to operate with no delay, enabling perfect synchronization.

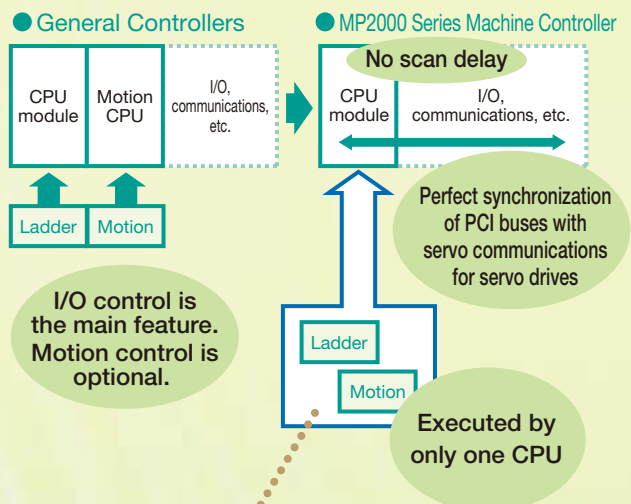

Synchronized Processing of Sequence and Motion Controls

The MP2000 Series Machine Controller precisely synchronizes motion with high-speed PLC scanning. The motion control starts within 1 scan from the start signal.

Also, the MP2000 Series Machine Controller can control different motions at the same time. The MP2000 Series Machine Controller's high-speed performance helps reduce tact time.

Reduction of tact time
Simultaneous execution of different motion programs (16 programs max.)

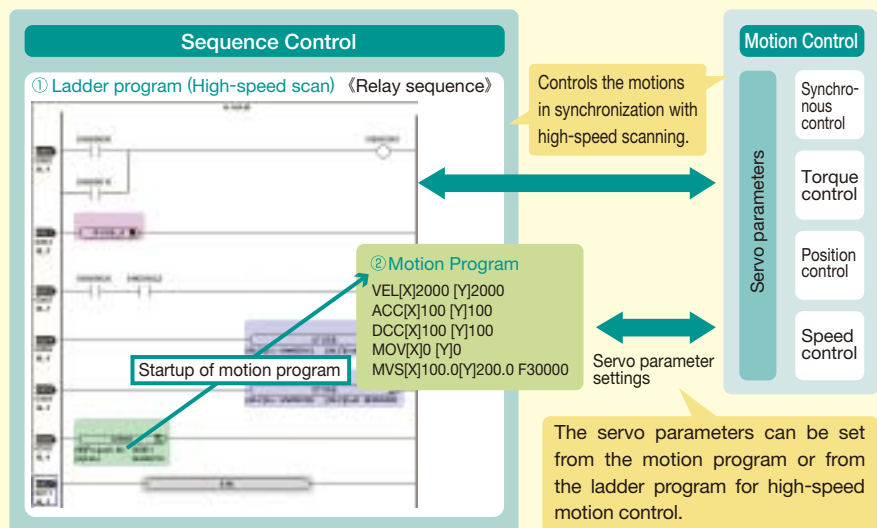

Electronic Shaft and Electronic Cam for Simplified Mechanics

With the MP2000 Series Machine Controller, AC servo drives that are connected to MECHATROLINK-II or III can directly control each axis of a machine.

Phase adjustment of each slave axis can be accomplished electrically on-the-fly, eliminating the need for mechanical adjustment. This simplification of the mechanical system results in reduced wear and reduced time spent on maintenance, setup, and part replacement.

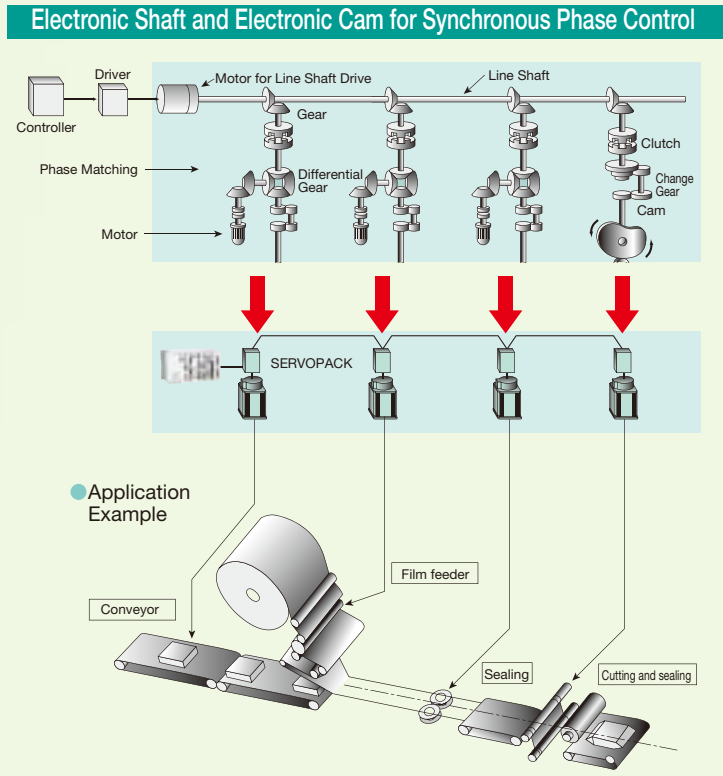

High-level Synchronization

Easy Creation of Electronic Cam Data

Cam Data Generation for Easy Programming

(integrated in MPE720)

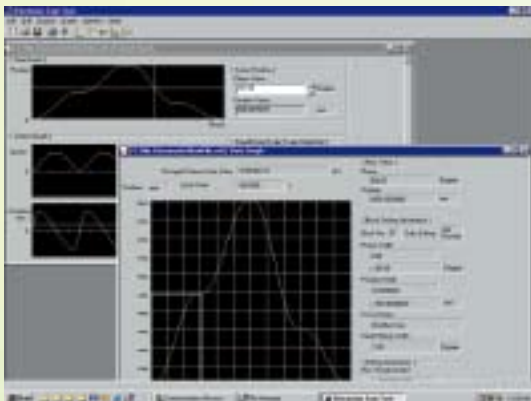

Cam curve definition

Define a formula for each cam segment. There is a maximum of 20 segments possible and 25 formulas from which to choose.



Execution with MP2000 Series Machine Controller

The data list is processed in the MP2000 Series Machine Controller.

Motions of the machine can be viewed and adjusted with the following graphs.

- Cam graph (displacement)
- Control graph (displacement, speed, acceleration, and jerk)

Feature 1

Flexible resolution settings

Resolution can be set for each block. High-precision cam curves can be created because resolution can be determined according to the complexity of the curve.

Feature 2

Select from among 25 different cam curves

A variety of cam curves have been prepared to express complicated machine motions. Fine adjustments can be made for each data point.

- Straight line ● Parabolic ● Simple harmonic ● Cycloid ● Modified trapezoid
- Modified sine ● Modified constant velocity ● Trapeclod ● Single-dwell cycloid m=1
- Single-dwell cycloid m=2/3 ● Single-dwell modified trapezoid m=1
- Single-dwell modified trapezoid m=2/3 ● Single-dwell ferguson trapezoid
- Single-dwell modified sine ● Single-dwell trapeclod ● No-dwell modified trapezoid
- No-dwell modified constant velocity ● NC2 curve ● Asymmetrical cycloid
- Asymmetrical modified trapezoid ● No-dwell simple harmonic ● Free-form curve
- Inverted trapeclod ● Paired strings ● Inverted paired strings



Systems Engineering with a Single Tool

High Operability

Optimum Engineering Tools for Motion Control & Dramatic Increases in Efficiency



MPE720 Ver.7
System Integrated Engineering Tool

MS Windows 7 Compatible

Easy Programming for Motion Control

● Motion Programs

Use only one command for interpolated motion. Programming is easy with a text-based language.



● Ladder Programs

With Windows-based operations, anyone can create or edit ladder programs.



Easy Motion Program for Positioning and Interpolation Control

Use an easy text-based programming language for complicated motion control.

■ Easy Programming for Interpolation

A wide variety of commands is available, so sophisticated interpolation can be programmed with only one command.

Commands	Functions
MOV	Positioning
MVS	Linear interpolation
MCW	Circular interpolation, Helical circular interpolation (clockwise)
MCC	Circular interpolation, Helical circular interpolation (counterclockwise)
ZRN	Zero-point return

```

WHILE M050==D;
MVS X:0 Y:5000 Z:0;
MCW X:5000 Y:5000 Z:0;
MVS X:5000 Y:5000 Z:0;
MCW X:5000 Y:5000 Z:0;
VEED;
  
```

■ Command Input Assistant

With the command input assistant, you can create a program without special knowledge of the syntax.



■ Variety of Debugging Functions

Functions, such as step-by-step program execution and breakpoint setting, are provided to simplify debugging.



■ BASIC-like Commands or Language

Control commands such as IF and WHILE as well as the user function call (UFC) can be used.

- A comment can be inserted using slashes (/) or quotation marks (" ").
- The repeat command (WHILE) and branching command (IF... ELSE) can be used.

```

/ THIS IS A COMMENT LINE
IF M001=1; M002=1; M003=1; M004=1;
WHILE M001=1;
M002=1; M003=1; M004=1;
END;
  
```

- Complex arithmetic expressions can be written.

```

M010000 = ( M020000 * M030002 ) + ( M040004 ) / 1000;
M010000 = 0;
  
```



■ Variables (register) and Arrays as Parameters

Indirect assignment with variables or arrays (subscripts i and j) can be used for parameters.

```

array [0] = 1;
array [1] = 2;
array [2] = 3;
  
```

Simplifies Writing of Complex Arithmetic Operations in Ladder Programs

Expression Instructions

C language-like arithmetic expressions can be written directly. Even the kind of complex arithmetic expressions that used to be hard to write in conventional ladder programs can now be easily written using the direct input function.

When writing arithmetic expressions in ladder programs

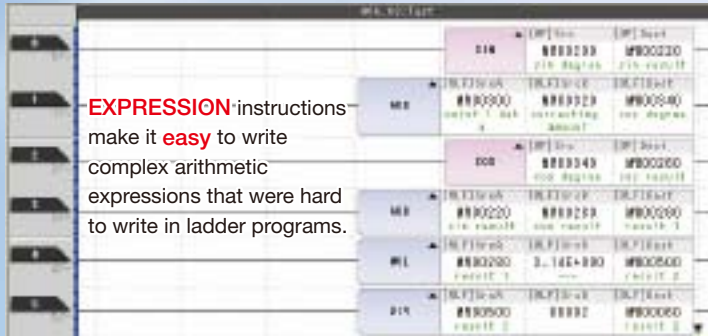

EXPRESSION instructions make it **easy** to write complex arithmetic expressions that were hard to write in ladder programs.

When **EXPRESSION** instructions are used

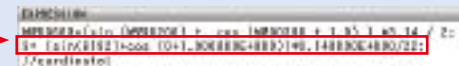

Current values shown under for **easier debugging**.

IF, FOR, and WHILE Statements

IF (condition), FOR and WHILE (repetition) statements can now be written inside EXPRESSION instructions to enable the execution of conditional expressions and repeat instructions, that posed difficulties in ladder programs.

A text editor is used so programs can be copied & pasted, making it ideal for simple positioning and interpolation programs.

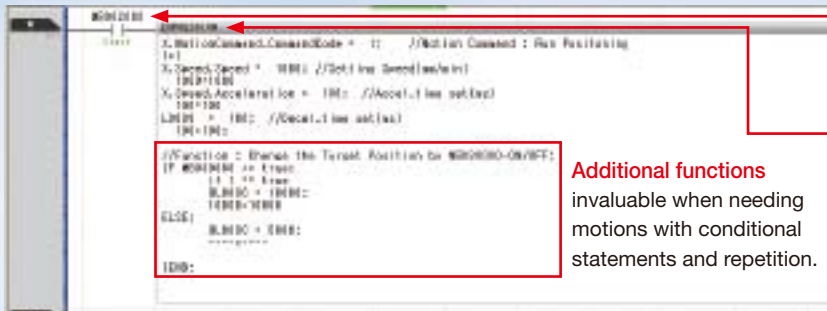

Additional functions invaluable when needing motions with conditional statements and repetition.

Interlock and other execution conditions are created in ladder programs

Motion control, operations and other aspects not very amenable to ladder programs are created using EXPRESSION instructions

Program Management and Database for Efficient Program Design

Hierarchy Programming

Ladder programs are organized in three hierarchical levels. The programs are grouped according to the type of process for easy identification of the structure. There are three types of program processes: start, high-speed scan, and low-speed scan. Programs can be duplicated by copying and pasting between different project files (MPE720 version 7 work files) for efficient and standardized programming.

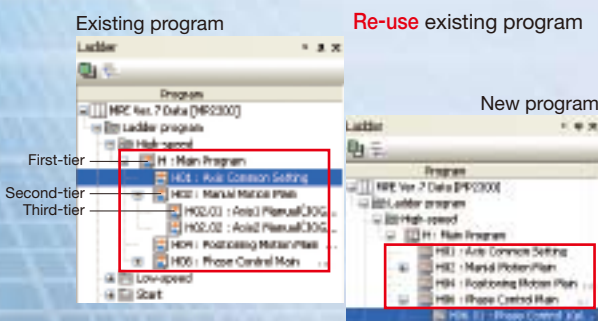

Variable Database

Each register (address + comment) is given with a variable name and identified by name in programs. Two types of variables are used: system setting variables prepared with MPE720 version 7 and user setting variables freely set by the user.

All variables are consolidated in the variable database of the MPE720 version 7 so that they can be shared between different project files.

Drag & drop ladder instructions and complicated axis variables to intuitively make settings **without a manual**.

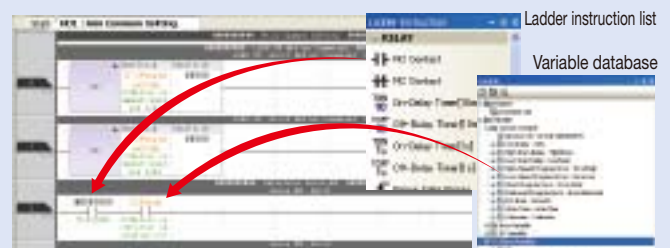



Supports Embedded C Language Application Programming (Optional)

Applications can be programmed in the widely portable C language, so existing software assets can be used. Confidential company information will not be leaked to a third party, because only object codes are loaded in C language.

No Additional Hardware Required

The embedded C language application is compatible with all standard products in the MP2000 Series. Though the runtime license is provided free of charge, the application development environment must be provided by the customer. MULTI integrated development environment and embedded API must be prepared by the customer.



C Language Application Development Environment

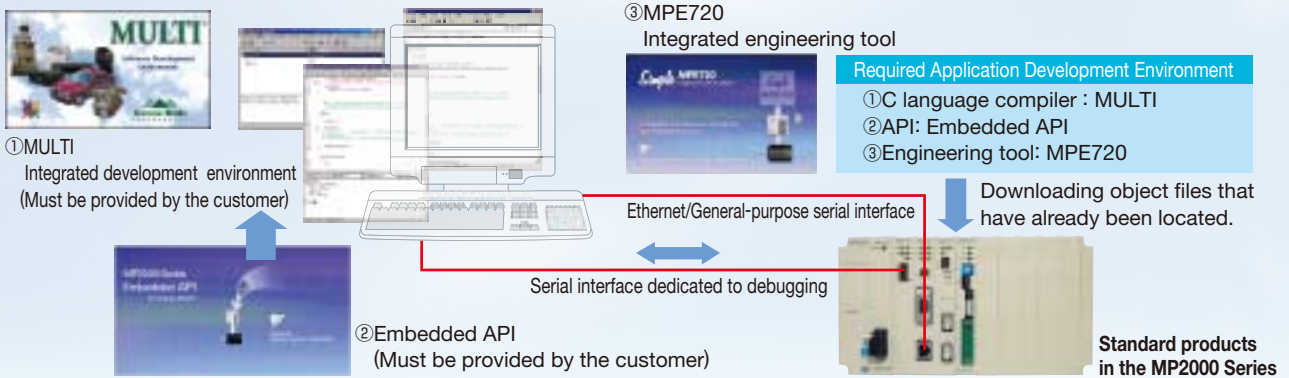

Note: Required development environment must be provided by the customer. The embedded API and MPE720 are available from Yaskawa Electric. For inquiries about MULTI (the integrated development environment), contact Advanced Data Controls Corp. For details, visit their website at <http://www.adac.co.jp/>. Yaskawa's technical support is required to develop applications using C language. Contact your Yaskawa salesperson or other Yaskawa representatives.

Compatibility with both Ladder Programs and Motion Programs

Ladder, motion, and C-language programs can be executed from the same CPU, enabling a smooth operation that doesn't depend on a single programming language.

- C-language tasks are executed independently from ladder programs.
- C-language programs can co-exist with ladder and motion programs.
- Synchronous operations with ladder programs and motion programs are also possible.
- C-language functions can be called from ladder programs, motion programs, and C-language tasks.

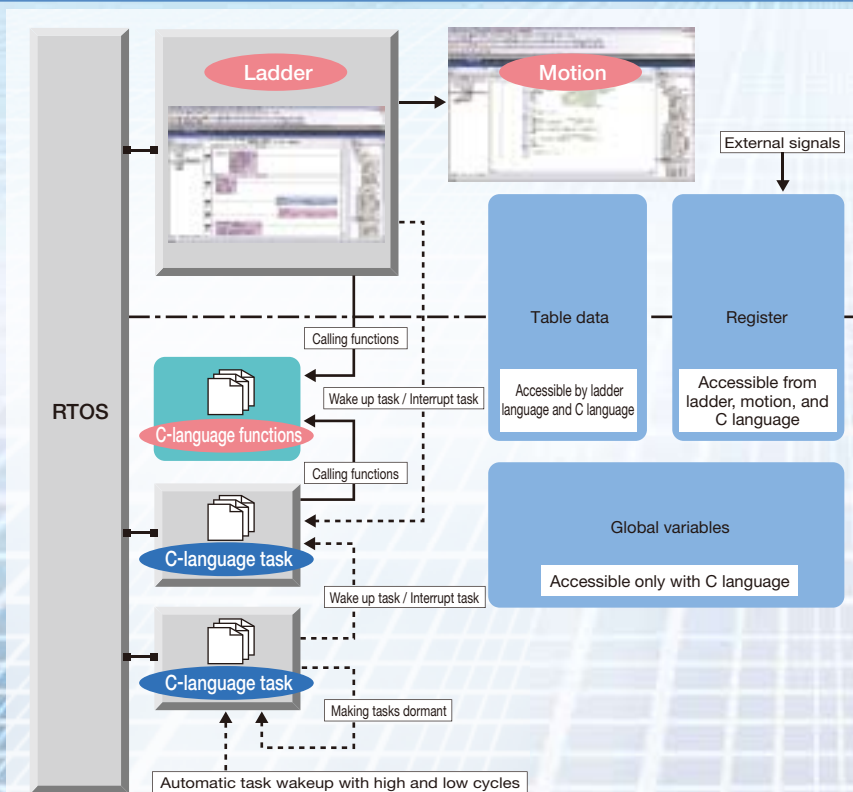

Can Adjust and Maintain All Drive Devices for the System

Setups, adjustments, programming, and maintenance of all drives connected to the network can be executed on a single personal computer screen.

All-in-one Engineering Tool for servo drives, inverters, and I/O units

MPE720 ver. 7 connected to machine controllers in the MP2000 Series allows you to adjust and maintain all AC servo drives and inverters connected to a network. Without the need to connect and disconnect a personal computer to each drive, adjustment and maintenance is now simple and efficient.

ALL-IN-ONE ENGINEERING

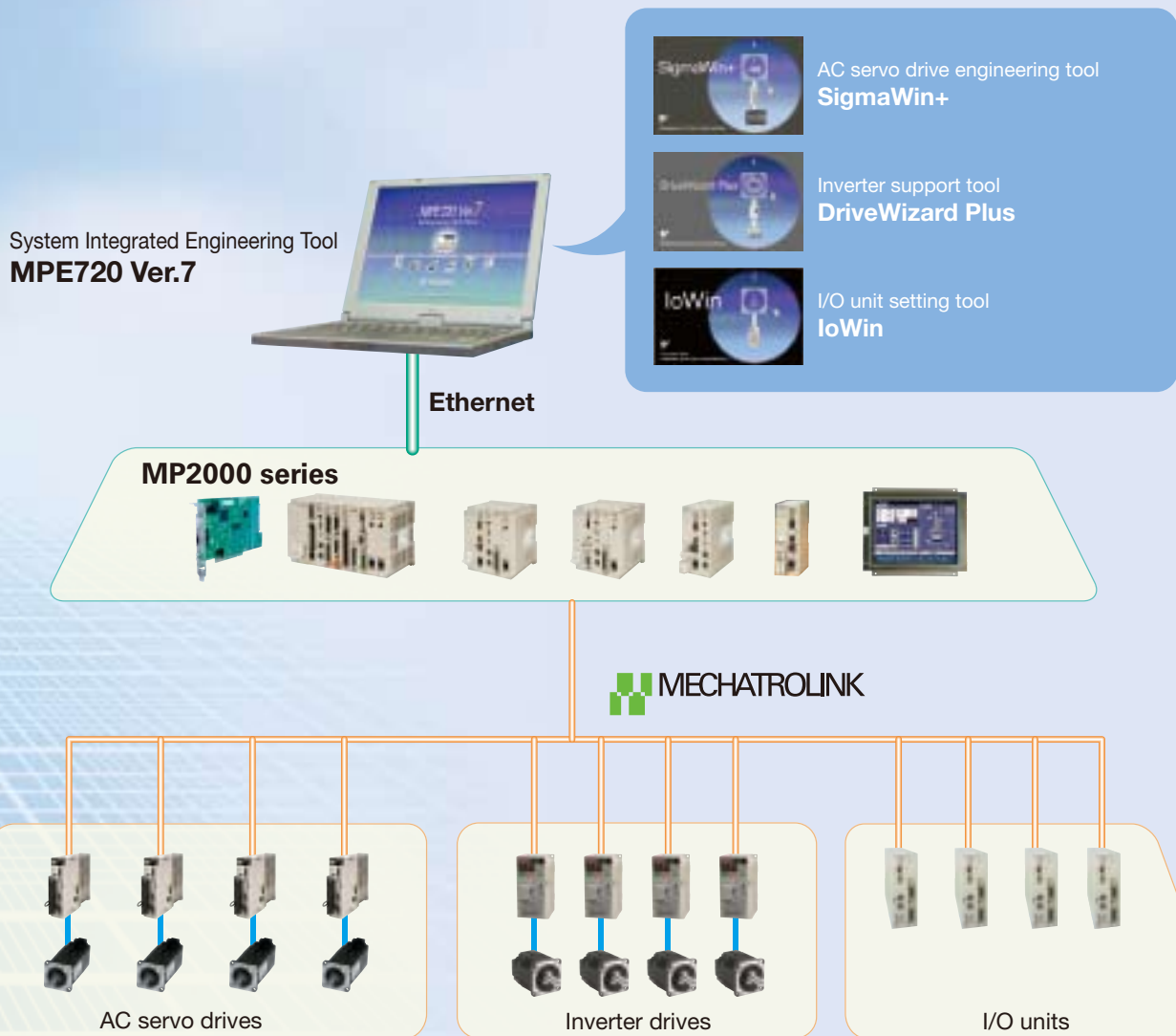
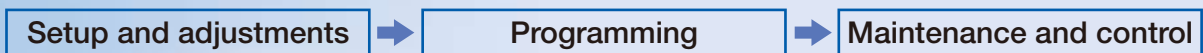



High Operability

Integrated control of all systems information, making entire system visible

MPE720 Version 7, Yaskawa's system integration engineering tool, has a function to automatically register each axis and establish other settings for the entire system as well as a function to simultaneously monitor and adjust multiple axes. These new functions can greatly reduce the time required to control multiple axes or large-scale systems.

Automatic setup of entire systems from controller to servo drives

Using MC-Configurator, the setup of an entire system can be executed automatically. Setup is accomplished from the controller to the servo drives easily just by connecting the power cables. This can also be done using the DIP switches on the machine controller.

System configuration set automatically

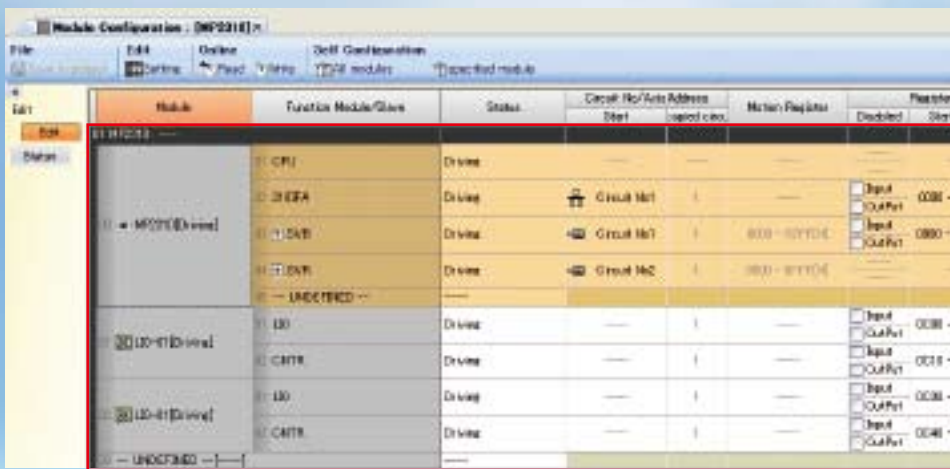

Execution of parameter settings and monitoring enabled for multiple axes simultaneously

The parameter settings and monitor windows of the drive units can be executed for a multiple number of axes simultaneously. Establishing the settings for the entire system is a simple job, and comparing the monitors on an axis-by-axis basis is also easy.

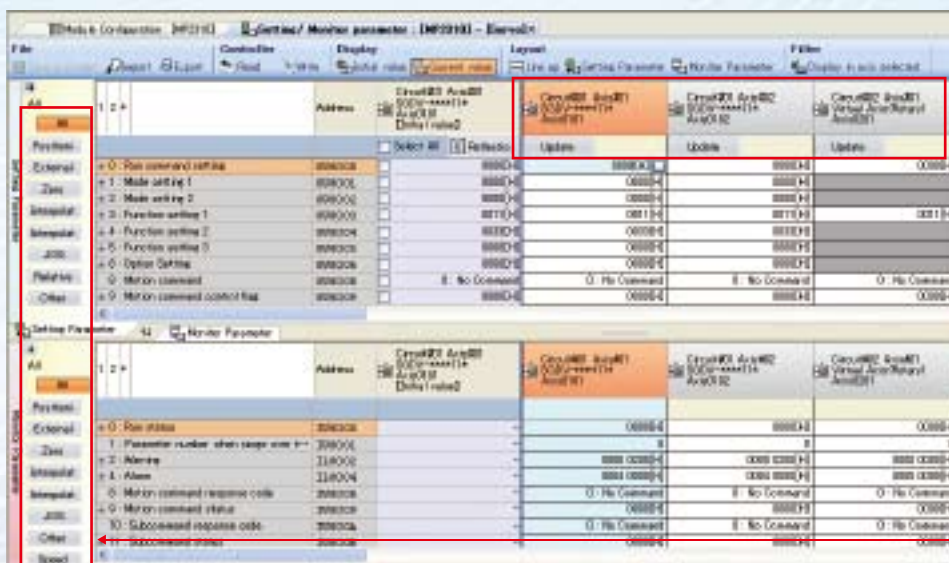

Simultaneous settings for more than one axis e.g. virtual axis, axis1, and axis 2

Single display for all settings and monitor windows

Single glance to check status of operations between multiple axes in monitor windows.

Select control mode to view only parameters in use

Streamlined servo adjustment

A wide variety of functions required for servo adjustments are provided, and these functions support the adjustment work. With the multiple windows, the adjustment process can be streamlined and time greatly reduced.

Multi-tasking

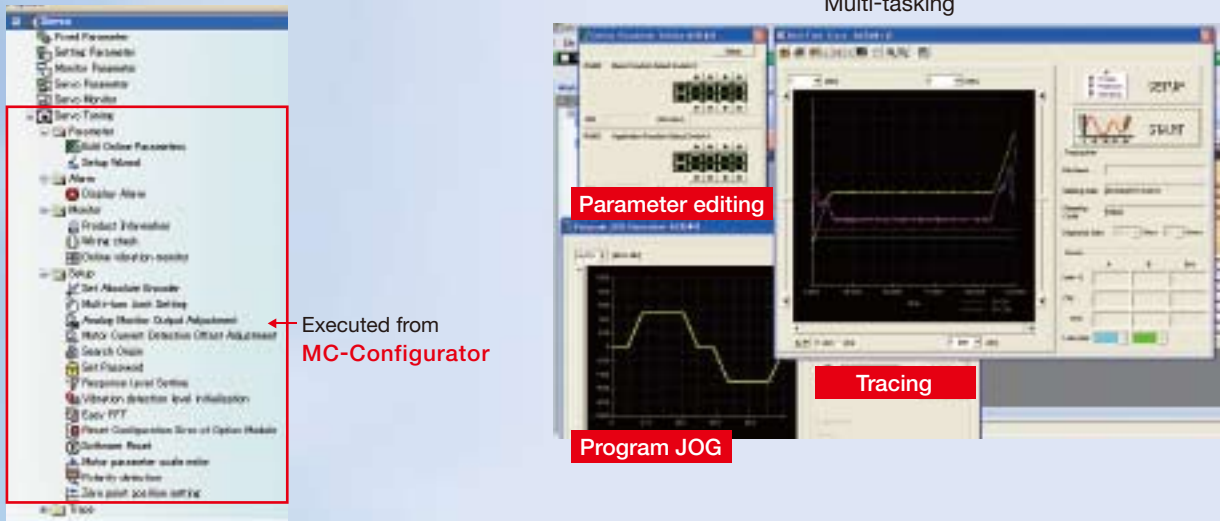

Using a 3-step setting procedure, anyone can easily initiate tracing

Just by following the setting procedure step by step, tracing is possible without having to refer to the manual.



• Trace data setting

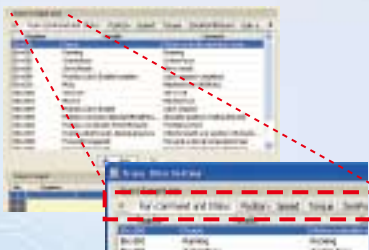

The registers to be traced are displayed by category for easy selection.

• Sampling & trigger setting



Conditions for initiating the trace can be set by one of four methods.

• Trace start



Speedy action taken to deal with trouble

If an alarm or a warning occurs, corrective actions can be made quickly from one of these windows: the axis operation monitor or the axis alarm monitor.

If an icon is clicked, the details of the error can be checked, and the alarm can be cleared without programming.

There are also links to the on-line help so speedy troubleshooting can be carried out.

Axis operation monitor

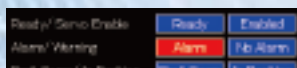

Axis alarm monitor

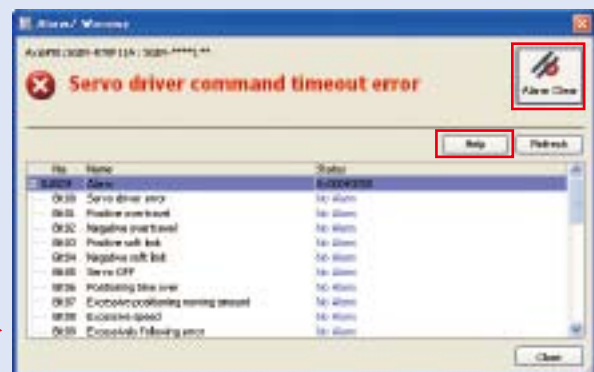



Optimizes System Configuration

Highly Expandable

Construct the Optimal System for Your Needs



Common Applications are Used for All MP2000 Series Machine Controllers

Need More I/Os for Your Connections with the MP2300S?

Solution Change to the MP2200 system. All applications can be used for the MP2200.

Need to Construct a Personal Computer Based System after Adopting the MP2310?

Solution Change to the MP2100 system. The same applications can be used. An API must be added to use the system with a personal computer.

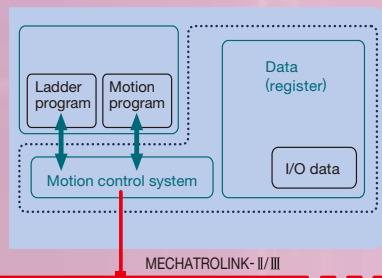

Personal Computer (PC)

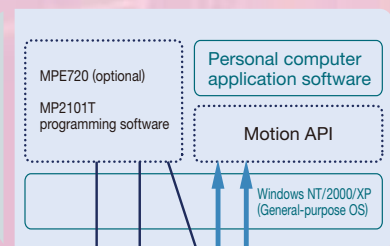

MP2101T

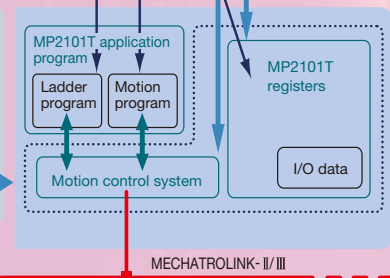

Program Conversion

Common Optional Modules Used for all MP2000 Series Machine Controllers*

The best optional modules for your device and system size can be selected.

* : Excluding MP2400

MP2200, MP2300, MP2310, MP2300S



MP2100M, MP2101M, MP2101TM

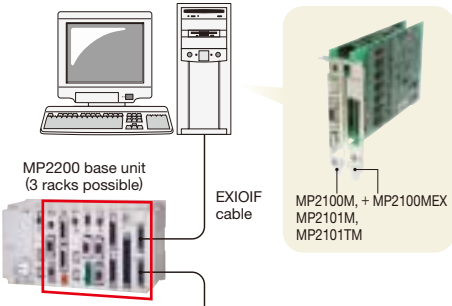

MP2200 base unit (3 racks possible)
EXIOIF cable
MP2100M, + MP2100MEX
MP2101M, MP2101TM

MP2500

MP2500ME
Expansion rack*

* : An expansion rack enables use of 3 to 24 optional modules.

MP2500B-OP/MP2500MB-OP

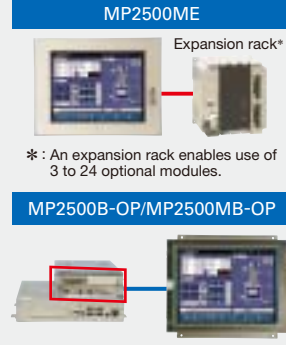



Optional Modules

- Communication Modules
- I/O Modules
- Motion Control Modules

Supports Various Open Networks

A variety of optional modules are available to support the networks your system uses.

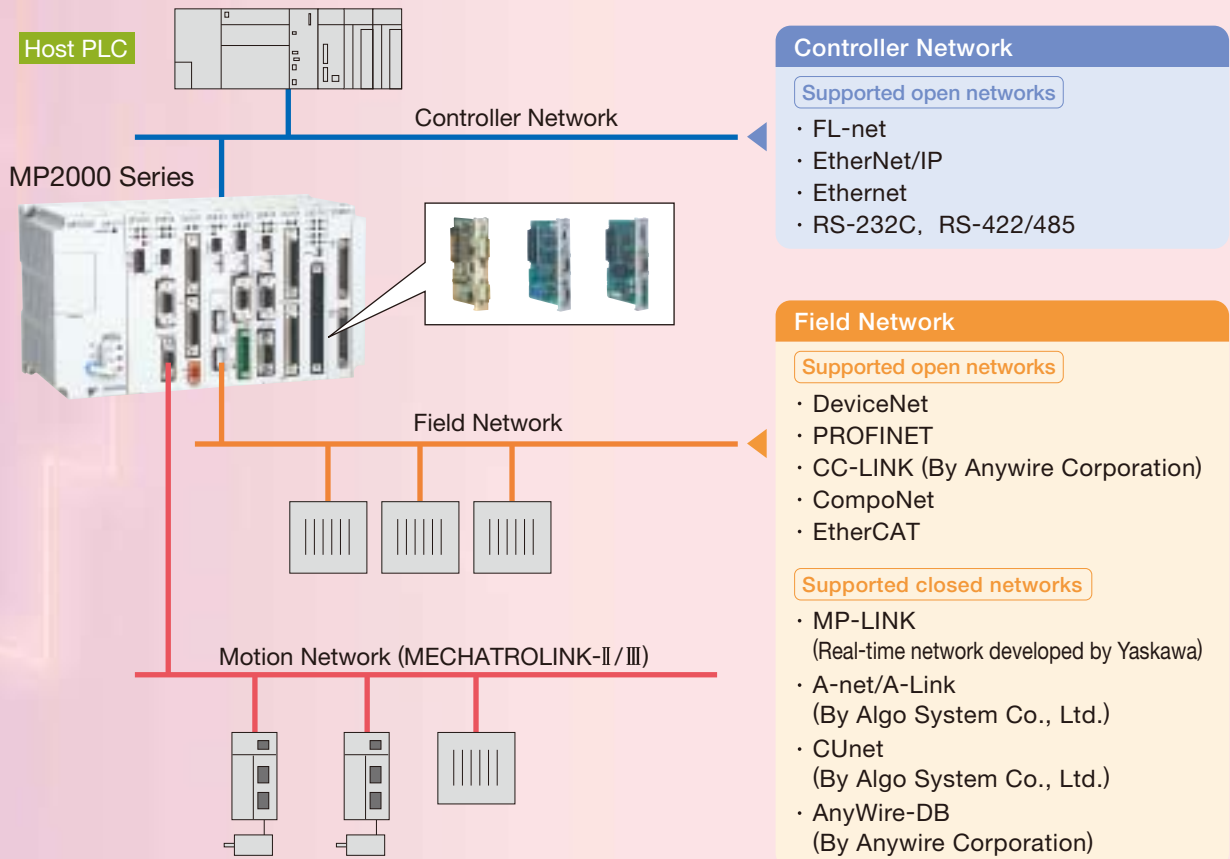



Optimizes Configuration of Motion Control System

Optimal Positioning

The Ideal Motion Control System for Servo Drives, Reducing the Time and Cost Needed to Construct a System

Easy Motion Program for Positioning and Interpolation Control

Use an easy text-based programming language for complicated motion control.

Easy Programming for Interpolation

A wide variety of commands is available, so sophisticated interpolation can be programmed with only one command.

Commands	Functions
MOV	Positioning
MVS	Linear interpolation
MCW	Circular interpolation, Helical circular interpolation (clockwise)
MCC	Circular interpolation, Helical circular interpolation (counterclockwise)
ZRN	Zero-point return

Variables (register) and Arrays as Parameters

Indirect assignment with variables or arrays (subscripts i and j) can be used for parameters.

Register	Value
ML30000	100
ML30002	300
ML30004	500
ML30006	510
ML30008	300
ML30010	100
ML30012

BASIC-like Commands or Language

- ① The repeat command (WHILE) and branching command (IF... ELSE) can be used.
- ② Complex arithmetic expressions can be written.
- ③ A comment can be inserted using slashes (//) or quotation marks (" ").

```

1  GOTO 1000
2  WHILE (X < 100) DO
3  GOTO 1000
  
```

Command Input Assistant

With the command input assistant, you can create a program without special knowledge of the syntax.



Easily Add Motion Control to an Existing PLC

You can construct a standardized drive system that can work with any PLC.

Positioning Systems that Use PLC

Problem When similar systems but different types of PLCs are used, motion control programs will be different for each PLC, as shown below.

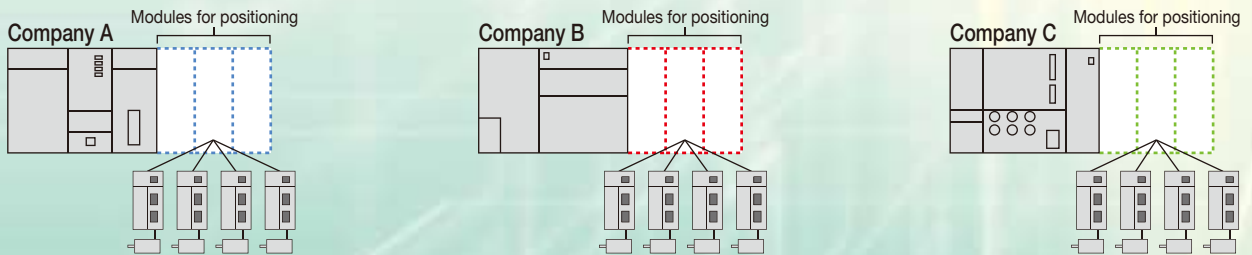

Positioning System with MP2000 Series

Solution The same motion control programs can be used by adopting the MP2000 Series, which can be connected to the PLC of each company.

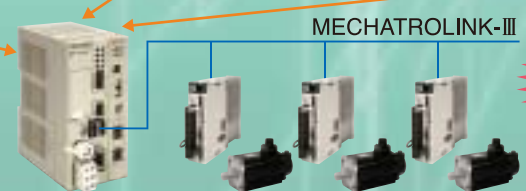
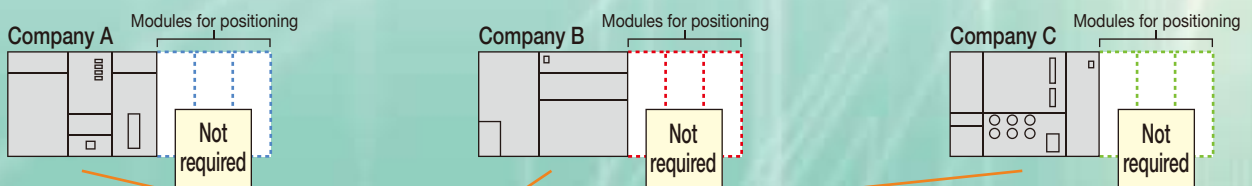

**Reduced wiring
High-speed control
16 axes**



A Variety of Support Tools

Middleware simplifies the communications setup between controllers and your personal computer **MPScope**

MPScope is the middleware for communications between MP2000 Series Machine Controllers and the host computer. With MPScope, you can easily add a function to application programs (Visual Basic or Visual C++) on the host computer to enable access to the registers and table data on the controller.

Main Functions

● Simplified Settings for Communications

Communications with machine controllers can be easily set with MPScope's function. Special knowledge or complicated programs are not required.

Before

Communication parameters were set in application programs. When the setting was changed, the application programs also had to be changed.



Now with MPScope...

Communication parameters can be set with MPScope. You only need to specify the file name and the connection number in the application program. Even if the setting is changed, the application programs do not have to be changed.



● Easy Programming

All the registers and table data for MP2000 Series Machine Controllers can be easily read and written. Just install MPScope in the host computer and add the register operation function to the application program.

- ① Start an integrated development environment, such as Visual C++, on the host computer running MPScope.



- ② Add the function for machine-controller register operations to the program.



For Monitoring and Managing Controller Information **MPLOGGER**

By installing MPLOGGER in your PC, you can

- Monitor the machine-controller data on an Excel sheet and
 - Save the machine-controller data at regular cycles in an mdb* database format in your PC.
- By enabling you to monitor data and make settings on a PC, MPLOGGER provides great back-up support for the operator and administrator.

* : Microsoft Access database



MPLOGGER, control information monitoring tool for machine controllers

Main Functions

● Simplified HMI Function

Has a simplified HMI function for monitoring the controller data by using the data as it is updated in the cells in an Excel sheet.



● Table Format Display/Historical Trend Graph Display

By using Excel functions and simple SQL commands, the data stored in.mbd files can be displayed in tables or historical trend graphs.



● Monitoring Function

Simply set the controller's address in a cell in an Excel sheet to view and set the controller's data.



Configuration Example

PC running Windows (MPLOGGER installed)



Applicable for Yaskawa's MP series of machine controllers. Applicable for MEMOBUS and Ethernet communications.



For Loading Application Program MPLoader

MPLoader is a data transfer tool that can be used to easily update the application program of machine controllers in the MP2000 Series without using the MPE720.

Functions such as system configuration definition, programming, and monitoring are not provided so that the original application program is secure and will not be overwritten.

Main Functions

● For Simplified Loading

The application program can be easily loaded to a machine controller if MPLoader is installed on your PC.



● For Machine Controllers in the MP2000 and MP900 Series

MPLoader can be used in a system that has different models of machine controllers from the MP series.

● For Compressed and Non-compressed Data

MPLoader can be used to decompress a compressed MAL file and load the data to the controller. Also, it can be used to batch load non-compressed PLC files. Data can be compressed as MAL files with MPE720 Ver.5.10 or later.



MPLoader, data transfer tool for machine controllers

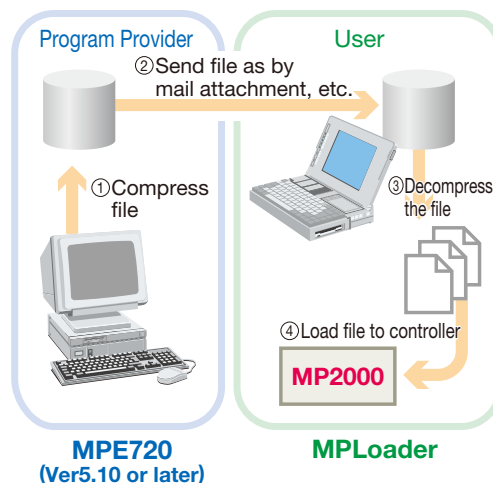

For Self-extraction and Automatic Transmission of Application Data

MPLoadMaker (For MP2100, MP2100M, MP2200, MP2300, and MP2310)

Main Functions

MPLoadMaker is a tool that is used to create an auto transfer data (Auto_MPL) with applications* for MP2000 Series Machine Controllers. When a CD-ROM containing the newly created data (Auto_MPL) is inserted in the PC (target PC) connected to the machine controllers, Auto_MPL will automatically decompress, open the application file, and send the data to the target controllers.

* : Applicable to MAL files (application files compressed as MAL files by MPE720 version 5) and YMW files (MPE720 version 6 work files).

Features

- Transfer of application data is possible even when the target PC does not have an application transfer tool (MPE720 version 5/version 6).
- A single CD-ROM can be used to automatically transfer application data to several machine controllers.
- Because the Auto_MPL function is limited only to decompression and transfers, the application data cannot be erroneously edited on the target PC.

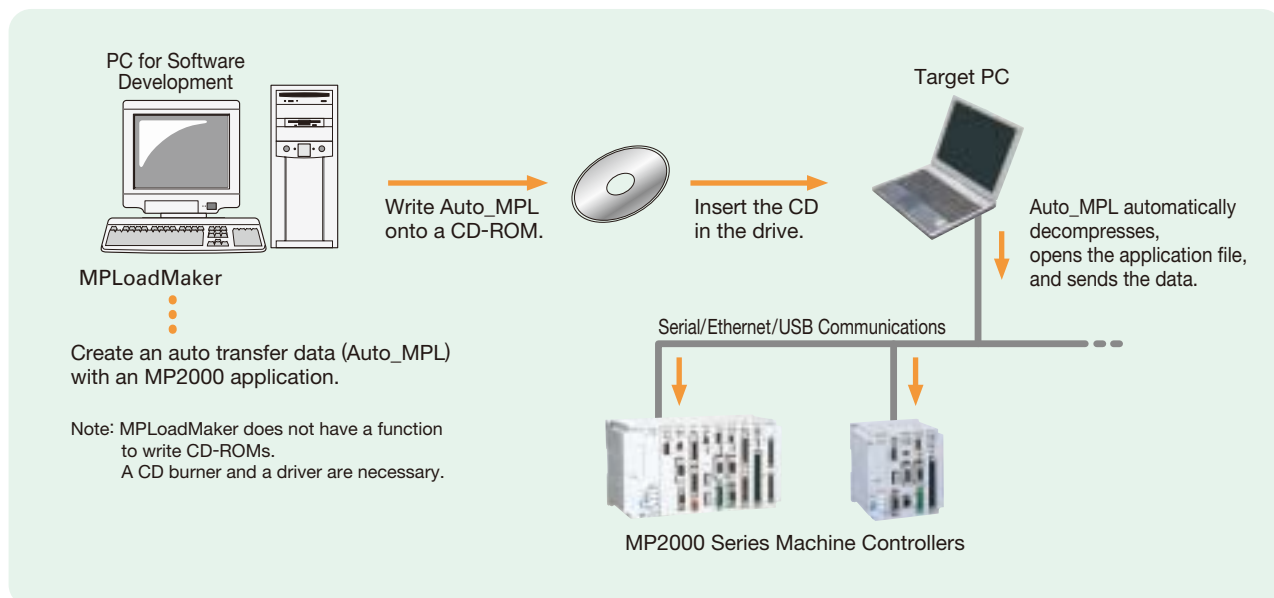

PCI Board Type Controller that Works in Harmony with Personal Computer MP2100(M), MP2101(M), MP2101T(M)

Ideal for

Devices used with personal computers.



No Special Computer Knowledge Needed

Problem...

Knowledge of computers is needed when using controllers installed on computers.

When the MP2000 Series is Used...

The same motion and ladder programs that are used for other controller series can be used here. Special computer skills are not required.



Downloading and debugging

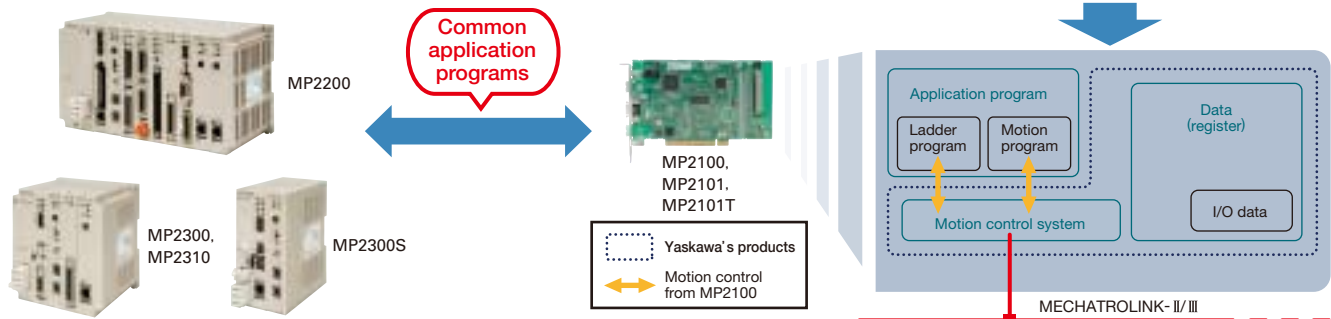

All-in-one Personal Computer

Problem...

You have computers, but now need controllers. That will require more space and wiring expenses.

When the MP2000 Series is Used...

- No need to add a power supply; it runs on an existing computer.
- Motion controls can be programmed directly and easily by accessing the MPE720 on a computer, via the PCI bus.
- The servo control function is provided as a standard feature.
 - ⇒ 16-axis and 32-axis controls are provided.
 - ⇒ A variety of MECHATROLINK-II and III compliant models are available.
- I/O can be expanded easily with MECHATROLINK remote I/O.

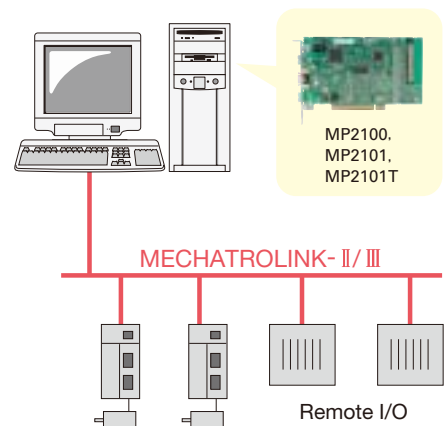

Name	Model	Specifications	Number of Controlled Axes
MP2100	JAPMC-MC2100-E	MECHATROLINK- II	Regular speed
MP2100M	JAPMC-MC2140-E		16 axes
MP2101	JAPMC-MC2102-E		32 axes
MP2101M	JAPMC-MC2142-E		16 axes
MP2101T	JAPMC-MC2102T-E	MECHATROLINK- III	High speed
MP2101TM	JAPMC-MC2142T-E		32 axes
MP2101T	JAPMC-MC2102T-E		16 axes

Easy Access to All Data from Personal Computer

Problem...

You want to have window displays on a personal computer to operate and monitor devices.

When the MP2000 Series is Used...

- With 51 extensive APIs, you can access all data through MS Windows programs.
- Simple and non-real time motion controls are available.

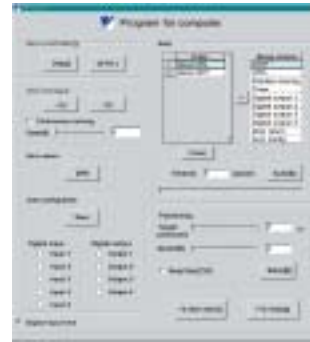

Motion API Window

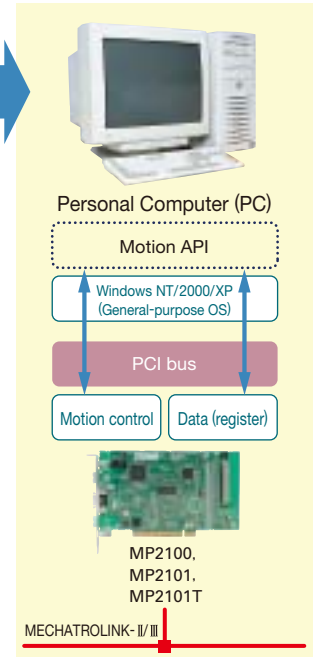

Main Motion APIs

Motion related API

- Device related: Servo ON/OFF
- Positioning: JOG feed, origin return, positioning, external positioning, and specified time positioning
- Interpolation: Linear interpolation, circular interpolation, and helical interpolation
- Torque reference • Gear function • Latch function
- Motion operation: Modification of motion data and parameters

System API

- Register operation: I/O operation • Alarm: Information acquisition and alarm clearing
- System operation: Opening, closing, and switching of object controller
- Operation calendar

Expandable - Up to 24 Modules and 3 Racks

Problem...

Board type controllers installed on personal computers lack expandability in local I/Os and communications.

When the MP2000 Series is Used...

- Up to 24 optional modules can be mounted on up to 3 racks when the MP2100MEX expansion I/F board for the MP2000 Series is installed.
- All optional modules for the MP2000 Series can be mounted.
 - ⇒Connectable to various open networks (Ethernet, DeviceNet, PROFIBUS, EtherNet/IP, FL-net, and CompoNet)
 - ⇒Connectable to various I/Os
 - ⇒Multi-axis control for up to 256 axes

Various Optional Modules Available!!



- Communication Modules
- I/O Modules
- Motion Control Modules

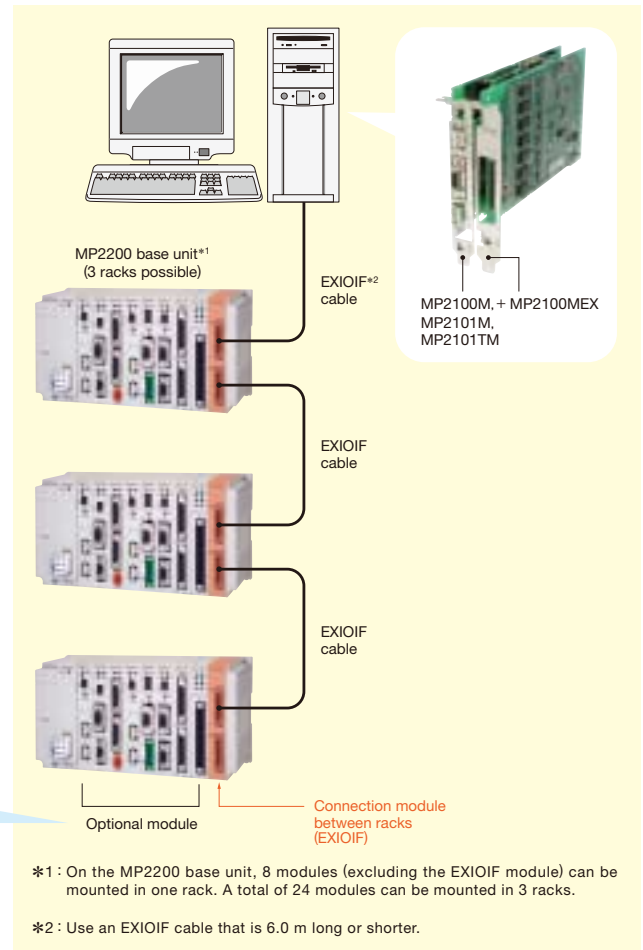

*1 : On the MP2200 base unit, 8 modules (excluding the EXIOIF module) can be mounted in one rack. A total of 24 modules can be mounted in 3 racks.

*2 : Use an EXIOIF cable that is 6.0 m long or shorter.

A Flexible, High-performance Module Type Controller that Expands to Meet the Needs of the System

MP2200

Ideal for

Systems that require reduced tact time and large scale systems that require sophisticated multi-axis control.



Select the Optimal CPU for Your System

Problem...

You need a CPU that provides the performance your system requires.

When the MP2000 Series is Used...

• Four different CPUs to choose from.

You can select the CPU you need to achieve the required tact time. By simply changing the CPU, optimum tact time can be realized at a reasonable cost because the programs are compatible.

• Base units are selectable.

Base units with slots (4 or 9 slots) are available and can be selected according to the needs of the system.

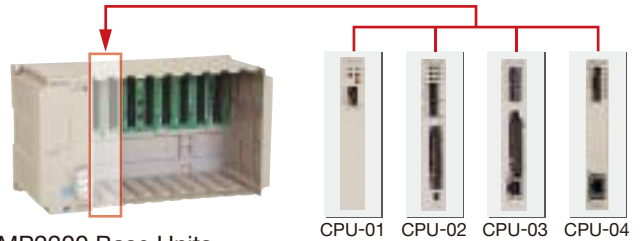

MP2200 Base Units

Name	Model	Description	Number of optional module slots
MBU-01	JEPMC-BU2200	85 VAC to 276 VAC	9
MBU-02	JEPMC-BU2210	24 VDC ± 20%	
MBU-03	JEPMC-BU2220-E	24 VDC ± 20%	4

Note: Attach a cover (sold separately; model: JEPMC-OP2300) to each empty slot.

Improved System Tact Time with High-speed CPUs

Problem...

Sophisticated new devices require more time for processing due to the increased number of calculations. Tact time for those devices needs to be improved.

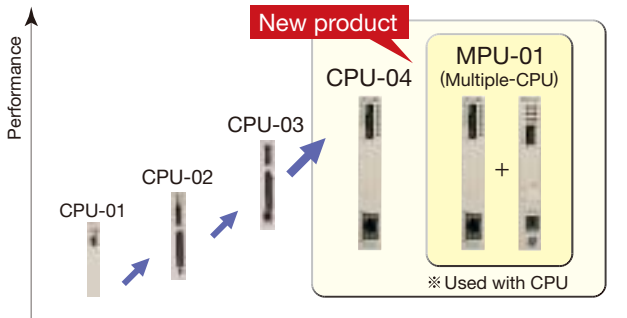

When the MP2000 Series is Used...

• Proven performance of the high-speed CPU-04.

Reduced application execution times. CPUs in the existing system can be replaced.

When the CPU-04 is used:

1000 IC chips are transferable every 30 seconds, in half the time of the CPU-02, so productivity is doubled.

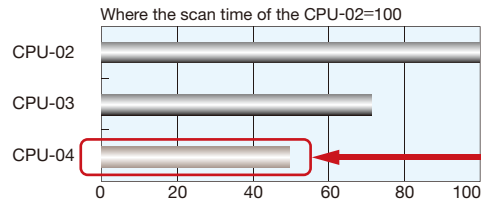

Twice as fast as CPU-02

Ultra High-speed Motion Control Achieved by a Distributed Processing System

Problem...

More time is required for the motion control cycle when a single CPU is used to control all axes.

When the MP2000 Series is Used...

• The scan time can be set to 250 μ s minimum.

Processing of programs can be split up by executing the motion control programs with the MPU. A total of 16 MPU-01 modules can be mounted and synchronized with the main CPU. (Scan cycle time: 0.5 ms minimum).

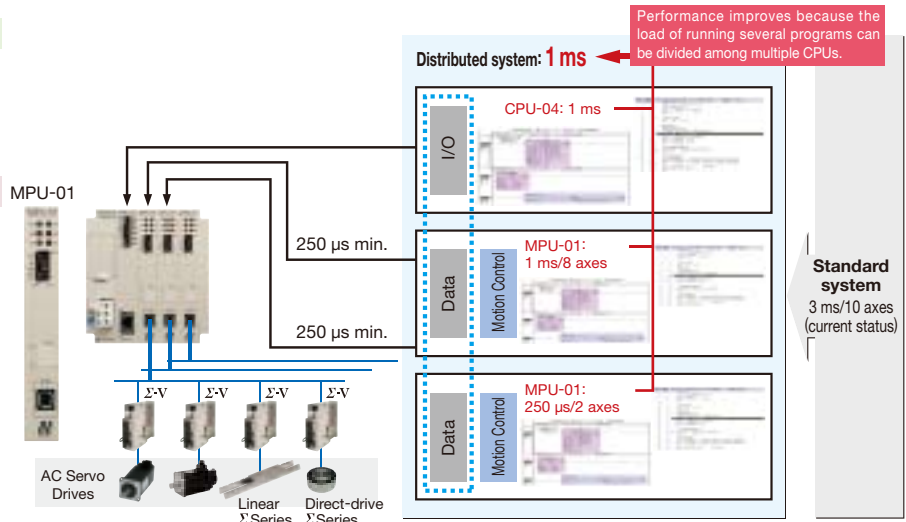

Wide Range of Optional Modules for Use with the MP2000 Machine Controllers (Excluding MP2400)

Problem...

As with PLC systems, motion control systems require various I/Os and connections to open networks.

When the MP2000 Series is Used...

The optional modules used are common to all MP2000 Series Machine Controllers. User friendly optional modules are available in a variety of types, and are compatible with open networks and various I/Os.

❖ Motion Control Modules



Connects to the SERVOPACK for motion control. Various MECHATROLINK slaves can be connected to the SVB-01 module.

Name	Model	Description	*
SVB-01	JAPMC-MC2310-E	MECHATROLINK-II × 1 channel	16
SVC-01	JAPMC-MC2320-E	MECHATROLINK-III × 1 channel	
SVA-01	JAPMC-MC2300	Analog-output 2-axis servo control	
PO-01	JAPMC-PL2310-E	Pulse-output 4-axis servo control	

* : Maximum number of modules that one CPU can control.

❖ I/O Modules



Provides digital or analog I/O interface.

Name	Model	Description
LIO-01	JAPMC-IO2300-E	Digital input: 16 points (sink output mode) Digital output: 16 points (sink output mode) Pulse input: 1 point
LIO-02	JAPMC-IO2301-E	Digital input: 16 points (source output mode) Digital output: 16 points (source output mode) Pulse input: 1 point
LIO-04	JAPMC-IO2303-E	Digital input: 32 points Digital output: 32 points (sink output mode)
LIO-05	JAPMC-IO2304-E	Digital input: 32 points Digital output: 32 points (source output mode)
LIO-06	JAPMC-IO2305-E	Digital input: 8 points Digital output: 8 points (sink output mode) Analog input: 1 channel Pulse counter: 1 channel
DO-01	JAPMC-DO2300-E	Digital output: 64 points (sink output mode)
AI-01	JAPMC-AN2300-E	Analog input: 8 channels
AO-01	JAPMC-AN2310-E	Analog output: 4 channels
CNTR-01	JAPMC-PL2300-E	Pulse-input counter

Note: One CPU can control unlimited number of modules.

*1: Maximum number of modules that one CPU can control.
*2: Estimates are required before ordering this product.
Contact your Yaskawa representative for more information.
Note: For RS-232C communications, 16 ports can be used.

❖ Communication Modules



Used to construct an open network. Modules with various types of interfaces are available.

Name	Model	Description	*1
2181F-01	JAPMC-CM2300-E	Ethernet (10BASE-T) port × 1 RS-232C port × 1	8
2181F-02	JAPMC-CM2302-E	Ethernet (100BASE-TX) port × 1 RS-232C port × 1	8
2171F-01	JAPMC-CM2310-E	RS-232C port × 1 RS-422/485 port × 1	8
2601F-01	JAPMC-CM2320-E	DeviceNet port × 1 RS-232C port × 1	8
2611F-01	JAPMC-CM2330-E	PROFIBUS port × 1 RS-232C port × 1	8
2621F-01	JAPMC-CM2303-E	FL-net (100BASE-TX) port × 1 (10BASE-TX) port × 1	8
2631F-01	JAPMC-CM2304-E	EtherNet/IP (Scanner and adapter) port × 1	8
2641F-01	JAPMC-CM2305-E	Port for EtherCAT slave × 2 (1 circuit)	8
2651F-01	JAPMC-CM2390-E	CompoNet port × 1	8
215AIF-01	JAPMC-CM2360-E	MPLINK communication/ RS-232C	8
215AIF-01	JAPMC-CM2361	CP-215 communication/ RS-232C	8
2661F-01	JAPMC-CM2306-E	PROFINET master*2	8
2661F-02	JAPMC-CM2307-E	PROFINET slave	8

MP2200

Expandable - Up to 35 Modules and 4 Racks, with Synchronization of Up to 256 Axes

Problem...

When using standard PLCs, multiple controllers must be used for larger scale systems, and the synchronization of many axes is hard.

When the MP2000 Series is Used...

- When the MP2200 is used, a large scale motion control system can be constructed with one CPU.
 - ⇒ Up to 35 optional modules can be mounted.
 - ⇒ 256 axes can be perfectly synchronized because the modules are synchronized.

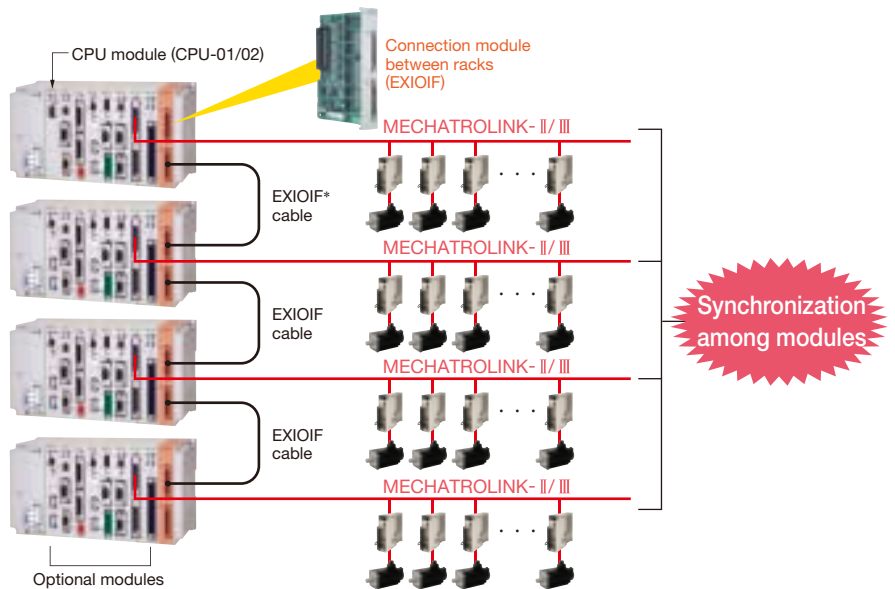

* : Use an EXIOIF cable that is 6.0 m long or shorter.

All-in-one Controller with Built-in Power Supply, CPU, and Functions for Network Communications and Servo Control

MP2300, MP2310, MP2300S

Ideal for

Pursuing better system cost performance, both in simple positioning and interpolation and in sophisticated multi-axis control.



Integration of Power Supply, CPU, Communications, and Servo Control

Problem...

Standard PLCs require a power supply, CPUs, positioning modules, I/Os and communication modules, increasing costs.

When the MP2000 Series is Used...

Whatever is needed for motion control can be integrated into the basic module.

I/Os and communications can be expanded by attaching optional modules when needed.

The same programs as the MP2200 can be used to fully support functions. This is an all-purpose controller to which any optional module can be mounted.



MP2300



MP2310



MP2300S

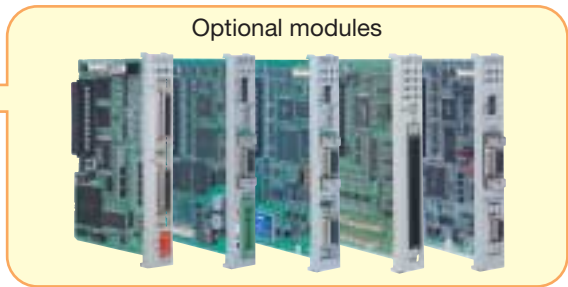

Optional modules

Name	Model	Built-in				Number of Slots	Maximum Number of Controlled Axes
		I/O	Communication	Servo Control	Standard Number of Controlled Axes		
MP2300	JEPMC-MP2300-E	Input: 8 points, Output: 4 points	—	MECHATROLINK-II×1	16	3	48
MP2310	JEPMC-MP2310-E	—	Ethernet×1				64
MP2300S	JEPMC-MP2300S-E	—				32	

High-speed Synchronous Distributed System with Multiple Controllers

Problem...

When using only one controller, the control cycle becomes longer.

When the MP2000 Series is Used...

The new slave-CPU synchronization function has been added to the standard motion network MECHATROLINK-II on the MP2310 and MP2300S. By connecting slave machine controllers to the master MP2000 Series Machine Controller with MECHATROLINK, synchronous operation between slave controllers is possible. In this way, the total load can be divided, so the load of each slave controller is reduced and high-speed synchronous operation for multi-axis motions can be performed.

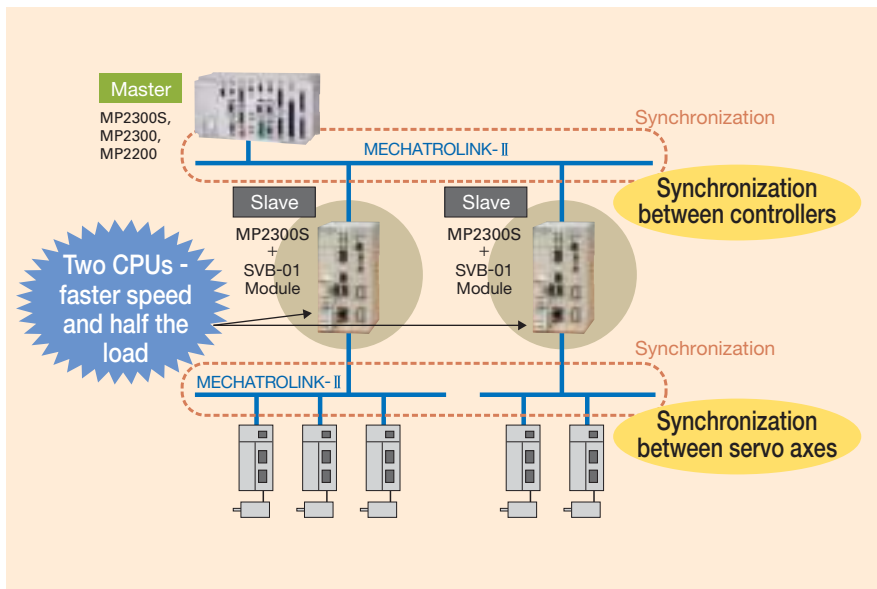

An Optimal and Compact Unit Controller that Provides a System with Positioning and an Interpolation Function with Less Wiring

MP2400

Ideal for

Small devices for simple positioning and interpolation.



Compact Controller Handles up to 16 Axes

Problem...

You have to construct a large scale PLC system even if all you need is a simple multi-axis motion system.

When the MP2000 Series is Used...

The MP2000 Series Machine Controller is equipped with a power supply, CPU, one MECHATROLINK-II for motion control, and Ethernet to connect with a PLC and HMI. The MP2400 can be connected to multiple devices without programming and can handle all jobs required. A motion distributed system can be constructed by connecting distributed I/Os and devices through MECHATROLINK.

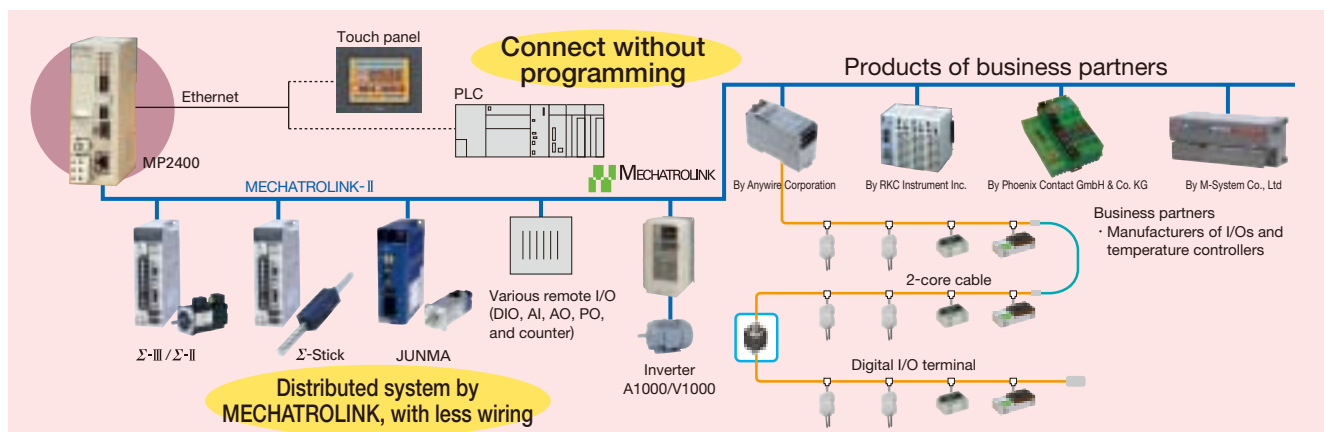

Free Download of MPE720 Integrated Engineering Tool

Problem...

You want to add some axes to the existing system, but new tool will be expensive.

When the MP2000 Series is Used...

The integrated engineering tool MPE720 Ver.6 Lite, dedicated to MP2400 machine controllers, is available for free. Download it from Yaskawa's Product and Technical Information on Yaskawa's website at <http://www.e-mechatronics.com>.

Positioning and interpolation control can be easily programmed with motion programs. Ladder programs are not supported yet.



MPE720 Version 6 Lite Integrated Engineering Tool

Motion Program Startup without Program when Connected to PLC

Problem...

You need a program to call up programs to execute if a PLC is used.

When the MP2000 Series is Used...

The motion programs can be executed without the need to call up programs from the host PLC. Simply register the prepared motion programs in their order of execution. By registering several motion programs, sophisticated motions are possible.

This All-in-one Controller Delivers a Smaller Motion Control System and Provides a Variety of Useful Data

MP2500/M/B/MB

Ideal for

Any system that needs to be compact but must still provide plenty of data.

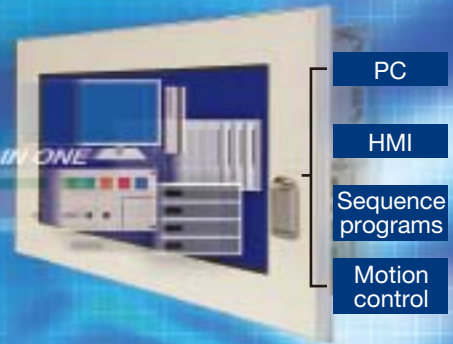

Sequence (PLC Function), Motion Control, and HMI (Panel Display) are Unified

Problem...

You need various devices, including a panel computer, a personal computer, PLCs, and controllers.

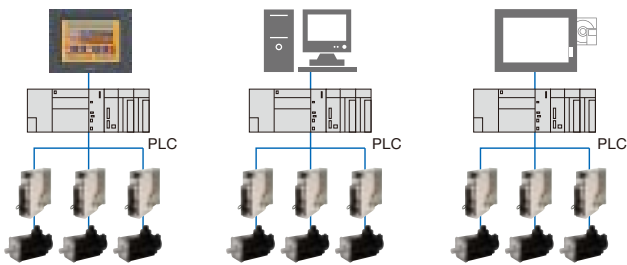

When the MP2000 Series is Used...

The integration of a panel computer with a controller in one unit will reduce system size and cost.

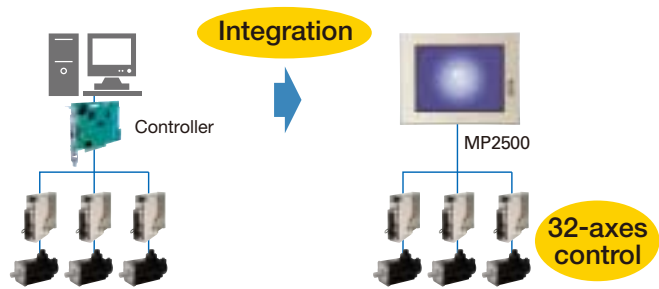

Flexible System Configuration

Problem...

You find it difficult to add I/Os and communications to panel and personal computers.

When the MP2000 Series is Used...

All optional modules for the MP2000 Series can be used.

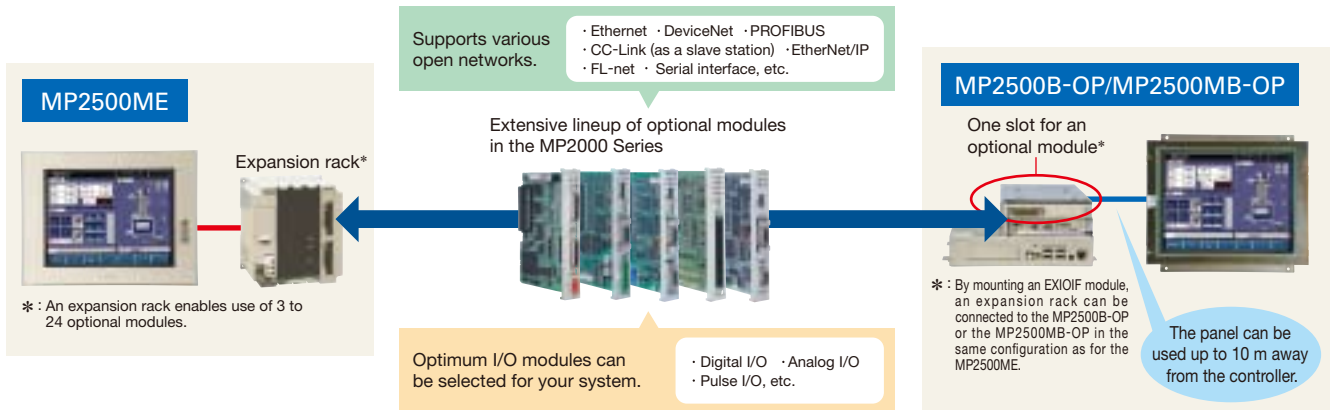

System Status Confirmation without a Personal Computer

▶▶▶ Controller and servo drive status can be monitored with standard feature displays.

Problem...

It is difficult to create the windows for various functions with a general panel computer and I/O terminals.

When the MP2000 Series is Used...

These windows can be easily created with the screen-creation tool. Windows for monitoring controllers and servo drives are standard features of the MP2000 Series, and ready for use.



Screen-creation tool MotionScreen



Register monitoring



Data tracing



Program monitoring

Tough against Vibrations, Power Outages, and Viruses

▶▶▶ With the compact flash card, no hard disk is required.

Problem...

With panel and personal computers, vibration, power outages and computer viruses are always a concern.

When the MP2000 Series is Used...

With no hard disk, the MP2500 controller is highly resistant to vibration. Computer viruses are fended off by the use of ROM, and the MP2500 controller will not crash even if there is a power failure.

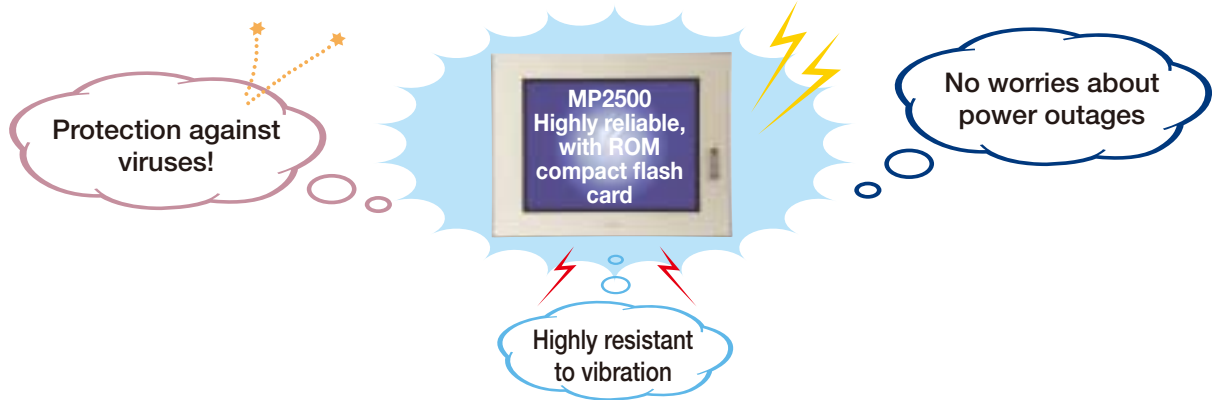

Strong Support for the Sophisticated Control Functions of the MP2000 Series

▶▶▶ Programs and motion control functions can be used with any controller from the MP2000 Series.

Problem...

Programs must be developed again when a different device and/or controller is adopted.

When the MP2000 Series is Used...

Various models are provided with common and interchangeable programs.

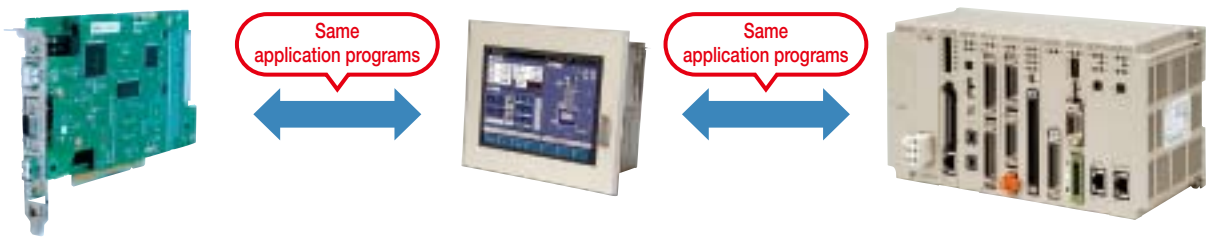

Engineering via Panel Computer

▶▶▶ All engineering can be done on a personal computer connected via the USB on the panel computer.

Problem...

You want to do maintenance without having to open the control panel.

When the MP2000 Series is Used...

No need to open the control panel. You can check the current status and make adjustments to the controller and servo drives by connecting the personal computer via the USB port on the panel (Uses the integrated engineering tool MPE720 and SigmaWin+).

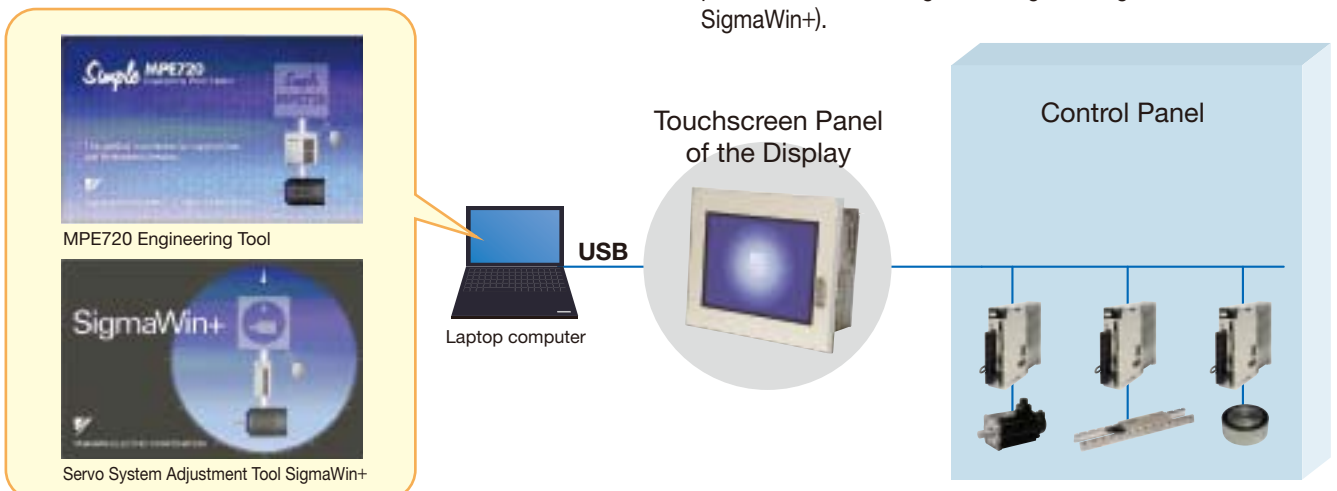



More about the MP2000 Series



1 Self-configuration Function

Try it!

Input definition settings that are necessary with other controllers are not needed, so the setup time is greatly reduced.

The MP2000 Series Machine Controller automatically recognizes the devices connected to MECHATROLINK-II.

- Optional module configuration definitions
- I/O register assignment
- Communication parameter settings (MP2200 and MP2300 only)
- Servo drives (servo parameters and parameters) connected to MECHATROLINK-II
- I/O points connected to MECHATROLINK-II

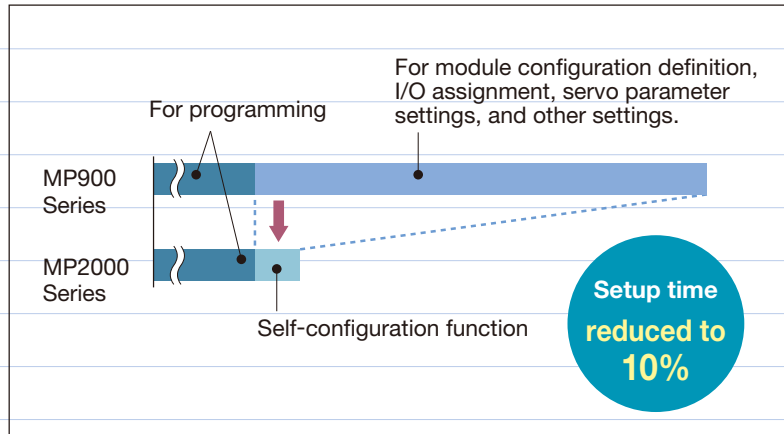

Self-configuration with DIP switches

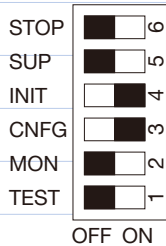

Set the DIP switches, INIT and CNFG, on the basic module or on the CPU module to ON, and then turn on the power supply.

More Information

- Any definitions that have been set with the self-configuration function will not be saved in the Flash ROM. Use the MPE720 to save these definitions in the Flash ROM.

Self-configuration with the MPE720

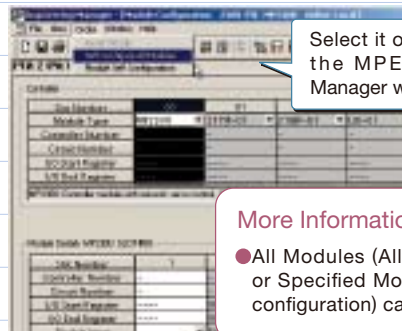

Select it on the order menu in the MPE720 Engineering Manager window.

More Information

- All Modules (All Self-configuration) or Specified Modules (Module Self-configuration) can be selected.

2 Application Converter Function*

Try it!

Existing programs can be easily converted for reuse.

*: Included in the Engineering Tool MPE720 version 5.

The ladder and motion program registers used in the MP900 Series can be converted for use in the MP2000 Series.

Notes: 1 For some registers and parameters, options must be selected before converting.

2 When using applications for the MP900 series with MPE720 version 6, compress the converted file into a MAL file.

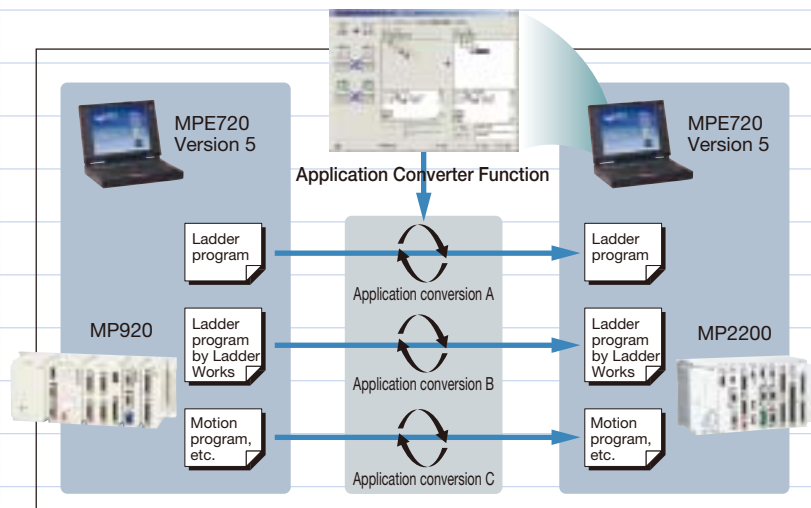

●MYVIS YV260 Network Machine Vision System Made by Yaskawa Electric Corporation

Example of System Configuration

In this example, the MYVIS YV260 is connected to the open motion network MECHATROLINK. With MECHATROLINK communications, the MYVIS can receive data on the current position of the motor's axes in succession. Using this data, the necessary adjustments are determined for high-accuracy calibration of the machine coordinate system.

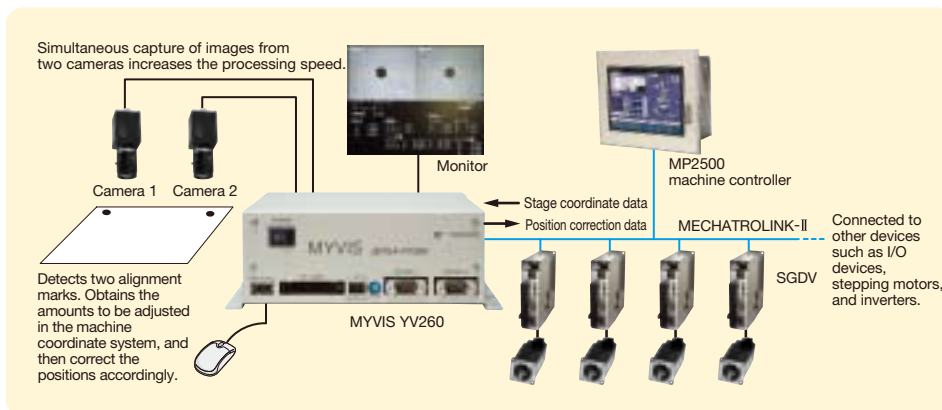

Item		For Analog Cameras	For Camera Link
Model		JEVSA-YV260□1-E	JEVSA-YV260□2-E
Image Processing		Gray scale pattern matching, binary image analysis etc.	
Memory	Application Program	512 Kbytes (flash memory)	
	Backup Memory	256 Kbytes CMOS (for saving parameters)	
	Template Storage Memory	CF cards (2 Gbytes max.)	
	Image Memory	Frame Memory	4096 × 4096 × 8 bits × 4 images (Can be used for 640 × 480 × 8 bits × 192 images)
	Template Memory	16 Mbytes	
Image Input	Camera Interface		Camera Link (MDR26pin) × 4
			VGA (640 × 480) to QSXGA (2440 × 2048), Base Configuration, PoCL-compatible
	Camera Power Supply		Single camera: 12 V, 400 mA, Total: 1.2 A
	Camera Sync Mode		Internal/external sync
	Random Shutter Supported		Sync-nonreset, sync-reset, single VD or V reset
	Simultaneous Image Capture		Four cameras
Monitor	Input Image Conversion		Gray level conversion (LUT), mirror mode
	Monitor Output		VGA, XGA (color), 15-pin D-sub
	Image Display		A full-screen or a partial-screen for one camera, simultaneous screen reduction for two or four cameras, gray level conversion (binary image display supported)
I/F	Field Network		MECHATROLINK- I/ II
	LAN (Ethernet)		10BASE-T/100BASE-TX
	General-purpose Serial		RS-232C × 2 channels (115.2 kbps)
	Parallel I/O		16 general-purpose outputs (4 of these are also used for stroboscope)
			+2 outputs exclusive for alarms (24 VDC, photocoupler isolation)
		16 general-purpose inputs (4 of these are also used for trigger) +3 inputs exclusive for mode switchings	
		+1 input exclusive for trigger (24 VDC, photocoupler isolation)	
Track Ball		USB mouse	
Power Supply		100 V/200 VAC, 24 VDC, 30 W	

Connect an MP2000 Series Machine Controller to a display monitor, such as one made by Digital Electronics, to view information about the servo axes or the status of your motion control system without a PC. Visualize your system with MP2000 Series Machine Controllers.

● **Programmable Display Unit Pro-face GP3000 Series** Made by Digital Electronics Corporation

Machine controllers, servo drives, and inverters can be adjusted and maintained with this display unit. You can easily check system startup and maintenance status, pinpoint the causes when an error occurs, and update or back up application programs with the display on-site without using a computer.

Features

- 1 Touchscreen to easily confirm the status of the MP2000 Series Machine Controller
- 2 Wide variety of windows to monitor all axes and the status of MP2000 Series Machine Controller
- 3 Register list to easily monitor and edit registers
- 4 Application programs can be updated or backed up by using the program transfer function, without using a computer.
- 5 Free samples of windows for various functions can be downloaded. No special device is required to set up screens.

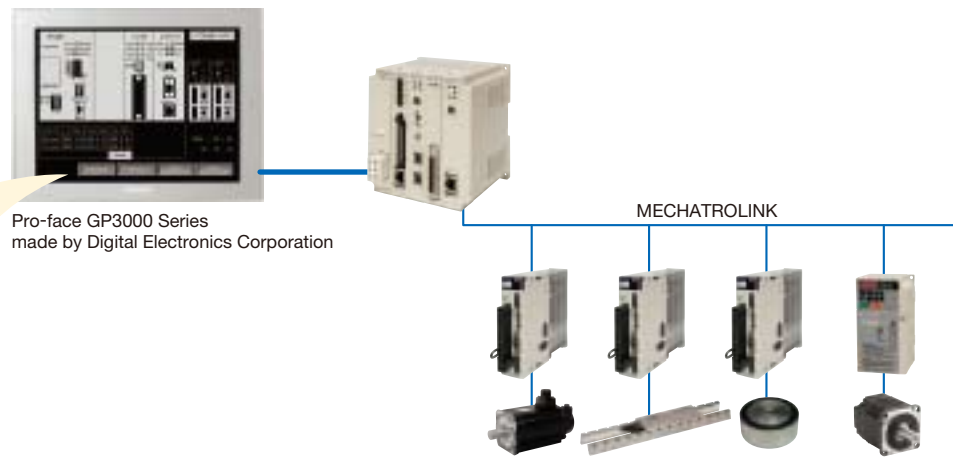

**Supports the Visualization Function
for the MP2000 Series Machine Controller**

The cockpit parts can be downloaded from the homepage of Digital Electronics Corporation:
<http://www.pro-face.com/otasuke/>



▲ Main Window
(with Symbolic and Pictorial Parts)



▲ System Error Status

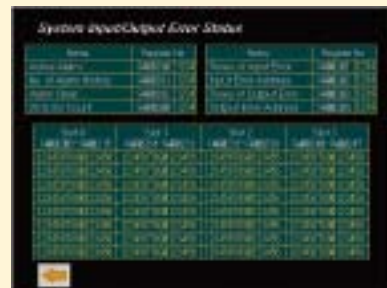

▲ System I/O Error Status



▲ Module Information



▲ Programs being Executed



▲ Axis Information

Engineering Support Function

● Program Transfer with an External Memory Unit!

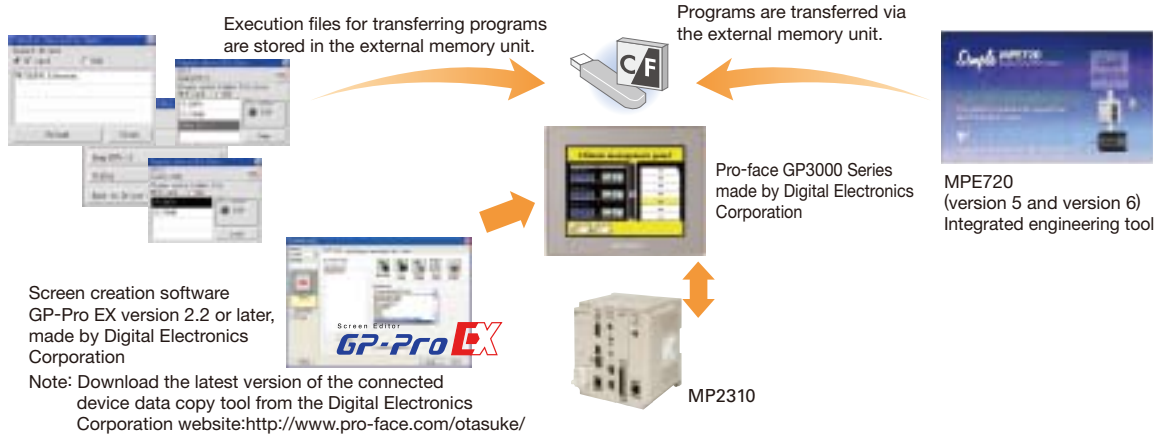

● Adjustment and Maintenance of Servo Drives and Inverters Right on the Touch Panel!

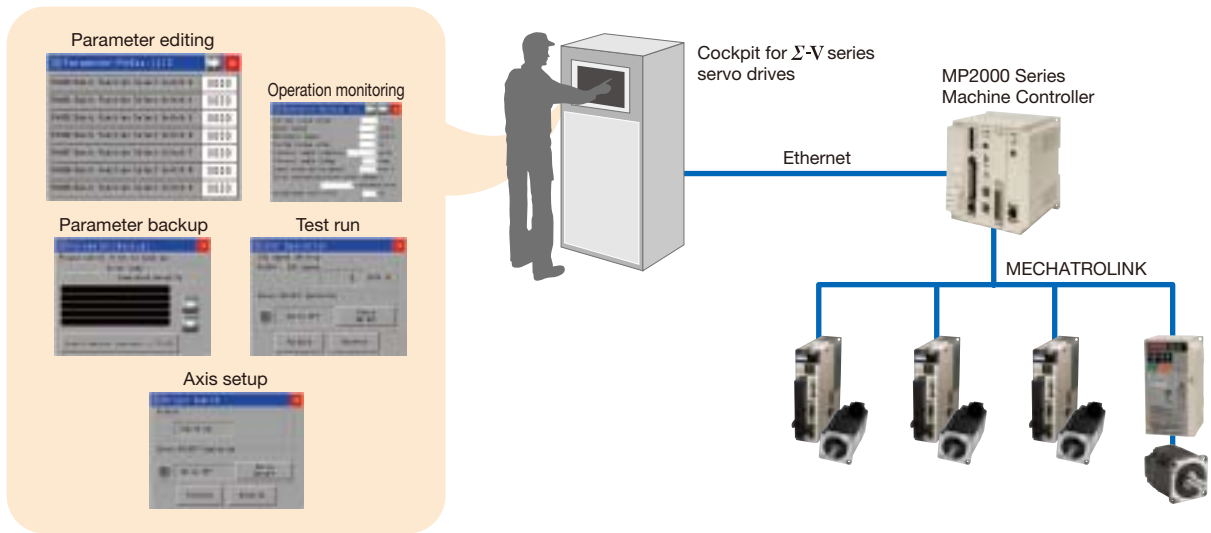

For the MP2000 Series Machine Controllers Third-party MECHATROLINK-compliant Devices

Partners of the MECHATROLINK Members' Association manufacture the following MECHATROLINK-compliant devices. These devices can be connected to the MECHATROLINK connector on any MP2000 Series Machine Controller for a bus with reduced wiring.

● Remote I/O R7 Series Made by M-System Co., Ltd

Connects different networks to one MECHATROLINK network.

- The R7 series of I/O modules has a power supply as well as communications section and I/O capability in a compact design. The R7 series is ideal for applications in which remote I/O is required because a small number of signals are scattered.
- No location restrictions
- Extension modules can be added to a basic module. One R7 module can be used for a variety of I/O signals, including analog I/O and contact I/O.

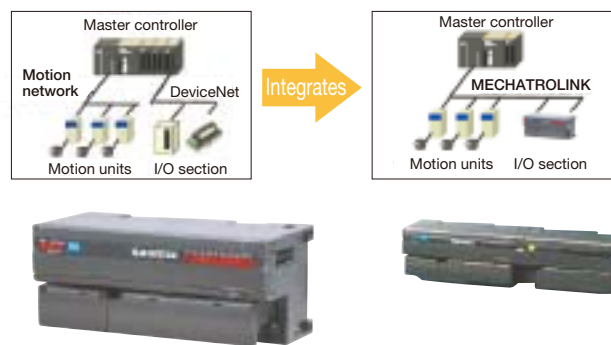

Note: For inquiries on R7 series Compact Remote I/O, contact M-System Co., Ltd. For more details, visit the M-System website: <http://www.m-system.co.jp/>

● MECHATROLINK Bit-type Distributed I/O Terminal

Made by Anywire Corporation

The MECHATROLINK Bit-type distributed I/O terminal contributes to the reduction of wiring required for drive systems that use MECHATROLINK-I/II.

Introduction of this new I/O terminal into a MECHATROLINK open-network system significantly reduces the total costs and increases system reliability, because the MECHATROLINK I/O terminal can be used with any transmission media such as robot cables and slip rings.

The Bitty series of I/O terminals from AnyWire can be connected to increase the flexibility in transmissions by supporting the connection of cables for signals from sensors and actuators in the system. Possible to expand number of I/O points to 432 by connecting I/Os with a bus that reduces the amount of wiring required.



Model : AB023-M1

Note: For more details on AFMP-01 module and AB023-M1 I/O terminal, contact Anywire Corporation or visit its web site, <http://www.anywire.jp>.

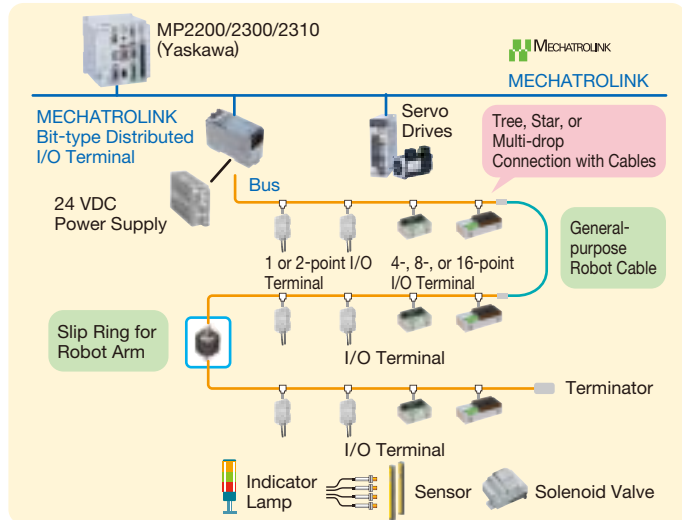

● No Out-of-step Stepping Motor and Driver Package

Made by Oriental Motor Co., Ltd.

- The MECHATROLINK-II compliant α STEP stepping motor and driver in the AS-series uses a unique closed-loop control and eliminates missed steps.
- The α STEP does not require tuning or hunting to achieve high-response positioning without any missing steps during sudden load changes or acceleration.
- Only one cable is required to connect the motor to the driver.
- A wide range of products including various types of geared motor, the EZ Limo motorized sliders, and the DG series of hollow rotary actuators can be connected and controlled with MECHATROLINK-II.



Note: For more information on ASD□□-□ME stepping motors, contact Oriental Motor Co., Ltd. or visit its website at <http://www.orientalmotor.com>.

Model: ASD □□-□ME

● Controller for Stepping & Servo Motors

Made by Melec Inc.

- Easy operation by combining I/O bit signals.
- Specially designed software enables you to make settings or confirm operation status on the personal computer.
- Individual control of four axes with compact motion controller: 88.5 × 94 × 59 mm (W×D×H)



Model: C-M581S

Note: For more information on C-580-series controllers, contact Melec Inc. or visit its website at <http://www.melec-inc.com>.

● MECHATROLINK Inline Bus Coupler for Modular I/O Systems

Made by Phoenix Contact GmbH & Co. KG

- The Inline bus coupler, model IL M II BK D18 DO4-PAC, has eight digital input terminals and four digital output terminals as a standard feature.
- The Inline modules for I/O signals can be expanded, and 52 modules can be connected.
- A wide range of input and output modules are available, including digital input, digital output, analog input, analog output, and temperature control modules.

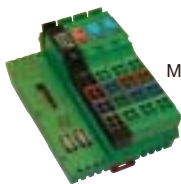

Model: IL M II BK D18 DO4-PAC



Digital I/O modules



Analog I/O modules

Note: For more information on IL M II BK D18 DO4-PAC, contact Phoenix Contact GmbH & Co. KG or visit its website at, <http://phoenixcontact.com/global/>.

● Module-type Digital Temperature Controller

Made by RKC Instrument Inc.

- Easily construct a multi-channel temperature control system by connecting the MECHATROLINK-compliant communications converter module to the temperature control modules.
- A single temperature control module can control temperatures of four points or two points. Also, 16 modules can be connected for temperature control of maximum 64 points.
- Digital I/O modules to output temperature alarms and to switch operation modes by using contact signals can also be connected.



Model: SRZ
Communications converter module COM-MY
Temperature control module Z-TIO
Digital I/O module Z-DIO

Note: For more information on SRZ temperature controllers, contact RKC Instrument Inc. or visit its website at <http://www.rkcinst.co.jp>.

Other Modules / Terminals : Not Available from Yaskawa

Modules from the listed manufacturers can be directly installed and used with the MP2200, the MP2300, the MP2310, and the MP2300S. A wire-saving bus can be formed with the bit-type distributed I/O terminal connected to the MECHATROLINK-cable connector of a machine controller in the MP2000 Series.

●AnyWire DB Master Module Made by Anywire Corporation

The AnyWire DB Master module allows a direct connection between the MP2200/MP2300/MP2310 /MP2300S controller and the AnyWire system. Because the AnyWire DB Master module has upper compatibility with the UNI-WIRE system, new ways to construct a system are possible.



Model: AFMP-01

Features

- 1 The AnyWire system reduces the wiring, time, space, and costs, because you can use general-purpose cables instead of the costly cables.
- 2 The Dual-Bus system realizes high-efficiency, high-speed transmissions and allows analog transmission (128W) to be connected without disturbing the digital transmission (512 I/O points).
- 3 Recommended for the drive section, which requires reduced wiring, because general-purpose robot cables, cableveyor devices, slip rings, etc. can be used.

System Configuration: Full Triple Mode Transmission

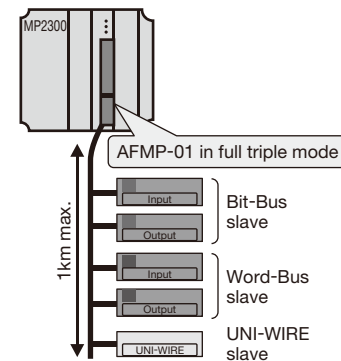

Note: For more details on the AFMP-01 module, contact the Anywire Corporation or visit its web site, <http://www.anywire.jp>.

●CC-Link Interface Board Made by Anywire Corporation

Slave interface board for connecting the MP2200/MP2300/MP2310/MP2300S to the host CC-Link. Two models are available: the AFMP-02-CA with an AnyWire DB port for reduced wiring and the AFMP-02-C without an AnyWire DB port.

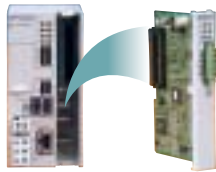

Model: AFMP-02-CA

Features

- 1 A single CC-Link master station, a PLC from the Q series by Mitsubishi Electric Corporation, can be connected to 16 MP2200, MP2300, MP2310, and MP2300S machine controllers with the CC-Link.
- 2 The setup time can be greatly reduced by the self-configuration function of the MP2200, MP2300, MP2310, or MP2300S.
- 3 Anywire port for reduced wiring saves costs and space.

Note: For more details on the AFMP-02-CA board, contact the Anywire Corporation or visit its web site, <http://www.anywire.jp>.

System Configurations

If a Q-series PLC made by Mitsubishi Electric Corporation is connected to a Machine Controller through CC-Link, only one CC-link master allows you to connect to 16 controllers including MP2200, MP2300, MP2310, and MP2300S Machine Controllers.

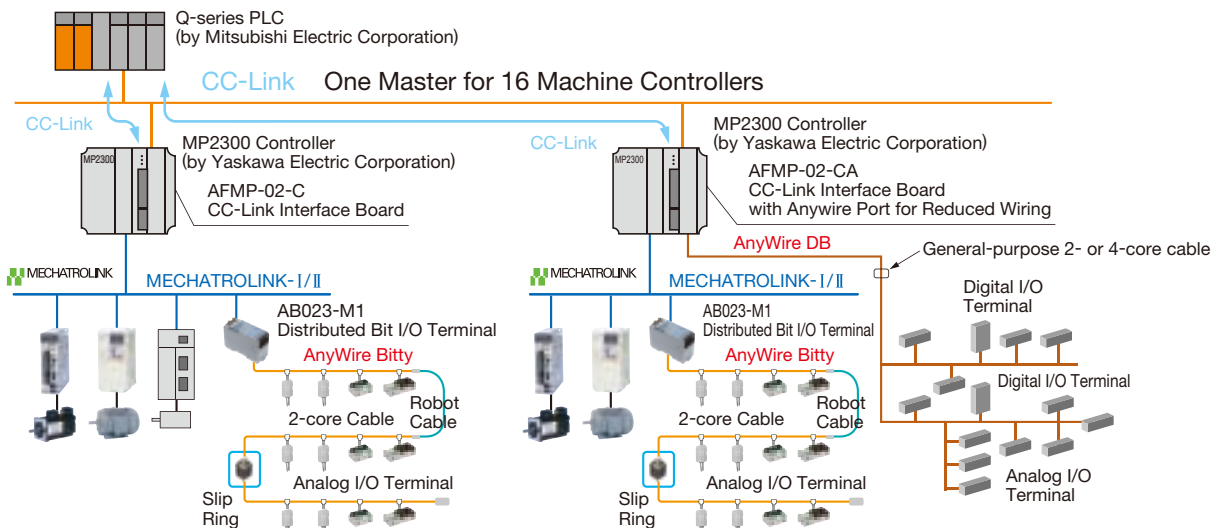

Other Modules / Terminals : Not Available from Yaskawa

●A-net/A-Link Master Unit Module Made by Algo System Co., Ltd.

This A-net/A-Link master unit module can be directly connected to the MP2200, the MP2300, the MP2310, and the MP2300S. The resulting system construction uses less wiring and conforms to SEMI E54.17.

Features

- 1 Two H8S units by Renesas Technology Corp. can be added.
- 2 Max. 4032 points can be scanned in 0.95 ms (at 12 Mbps).
Note: Using two A-Link systems (2016 points/system, 0.95 ms at 12 Mbps).
- 3 Shared memory of 512 Bytes (response speed: 2.36 ms) with A-net.
- 4 Self-diagnostic function.

A-net
Max.number of slaves: 64

A-Link
Max.number of slaves: 63



Model: MPANL00-0

Note: For more details about the CUnet master unit module (MPCUNET-0), contact Algo System.
For more information, visit the following website.
<http://www.algosystem.co.jp>

●CUnet Master Unit Module (Model number: MPCUNET-0) Made by Algo System Co., Ltd.

The master module for CUnet communications that can be directly connected to the MP2200, MP2300, MP2310, and MP2300S machine controllers.

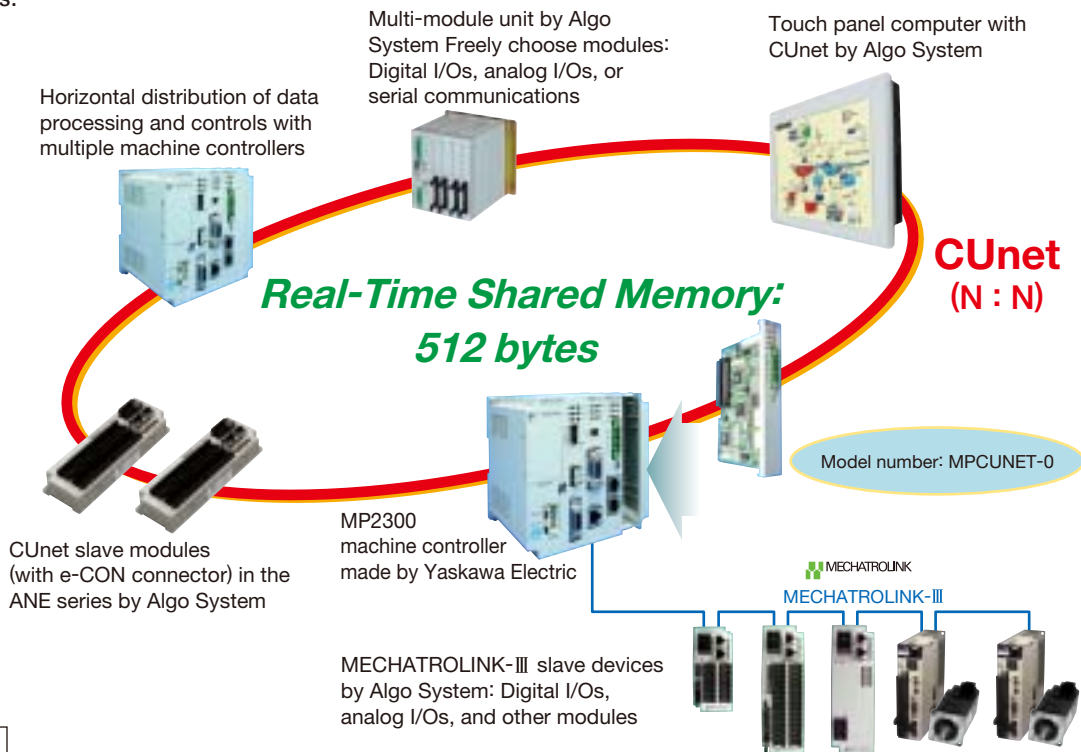

Features

1. Pre-mounted H8S unit (By Renesas Electronics).
2. Large shared memory of 512 bytes (Response speed: 2.36 ms).
3. Distributed control in real time.

Note: For more details about the CUnet master unit module (MPCUNET-0), contact Algo System.
For more information, visit the following website.
<http://www.algosystem.co.jp>

Reconfiguring Systems with the MP2000

When a Standard PLC with Positioning Module and Pulse Train Interface is Used

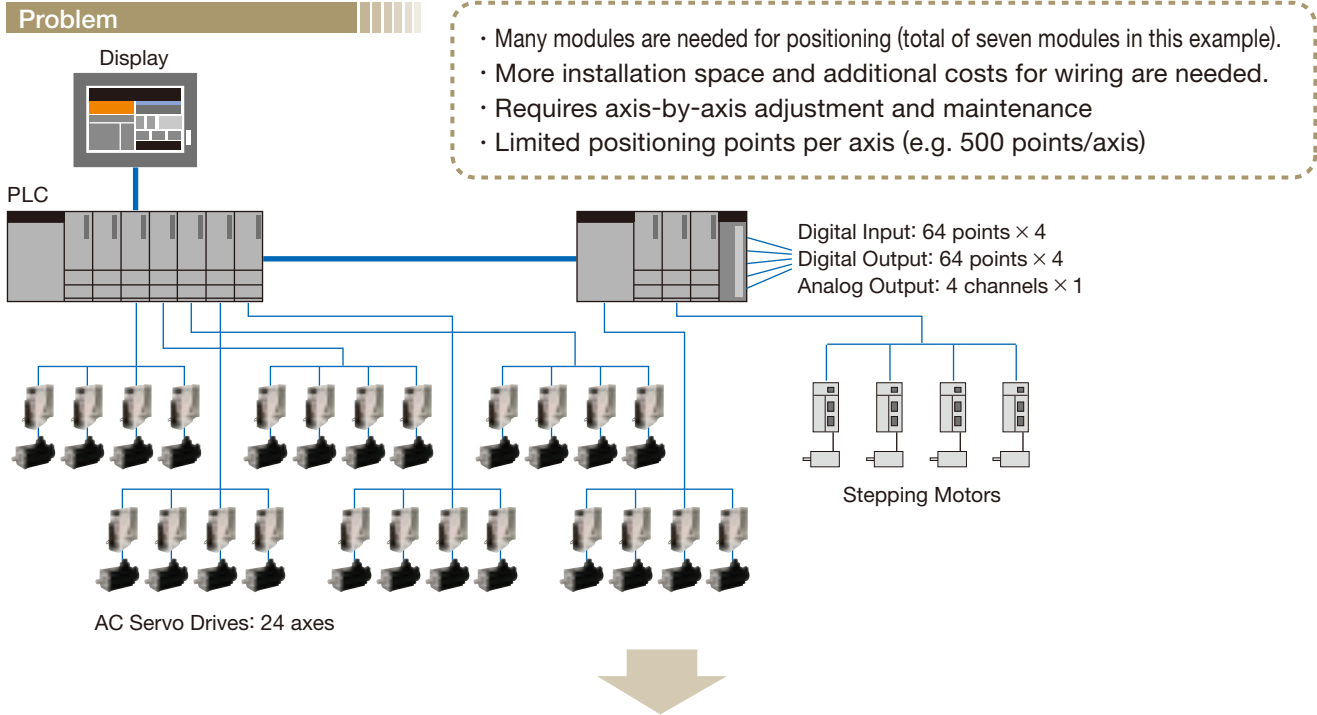

Advantage of the MP2000 Series Machine Controllers

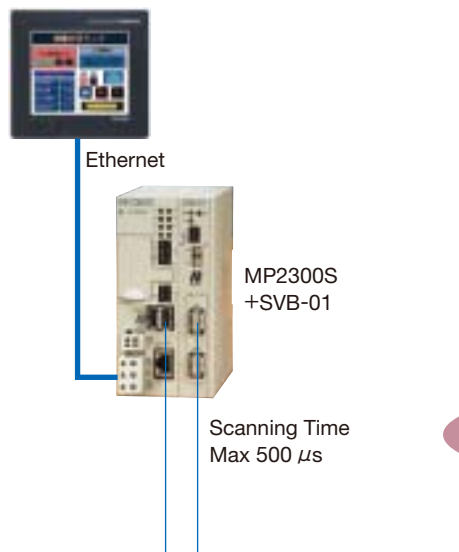

- The MP2300S is a reasonably priced machine controller that can control up to 16 axes with its basic module. It can control 32 axes if an SVB-01 module is installed.
- Wiring costs and installation space are reduced with reduced wiring.
- All axes can be adjusted and maintained with a personal computer connected to the MP2000 Series Machine Controller.
- High-speed image recognition enables non-stop alignment, delivering high-speed motion control.
- Servo drives and I/Os can be easily expanded.
- Positioning programs can be easily created with motion programs.
- A position table (max 65535 words) can be used. (Up to 2MB when the table data function is used.)

Reasonably priced

Highly expandable
(Servo drives and I/Os can be easily expanded)

Reduced wiring, cost and installation space

Non-stop alignment

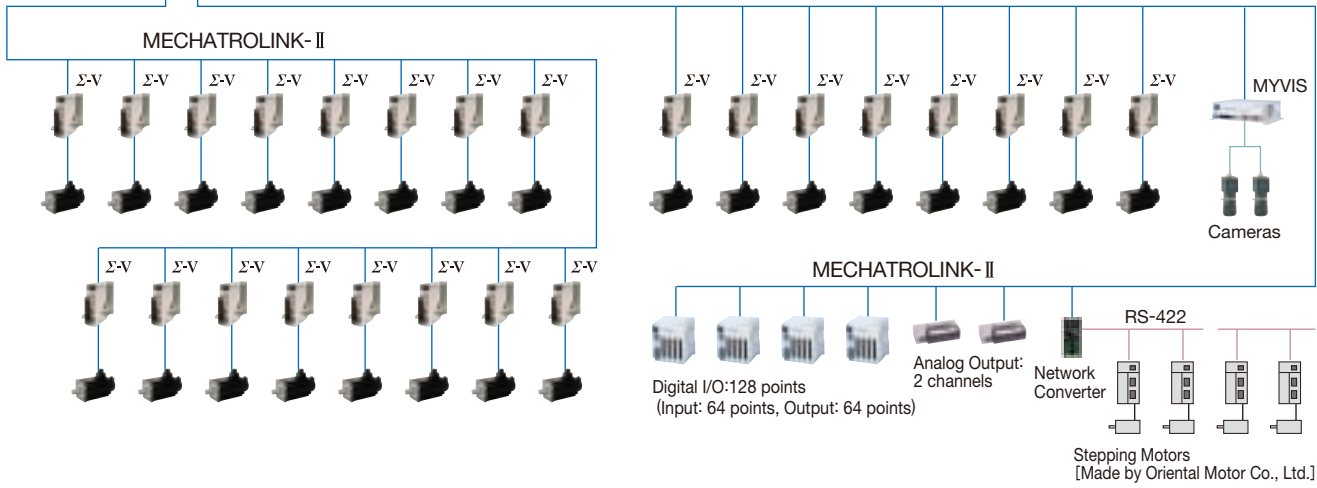

Reconfiguring Systems with the MP2000 (Cont'd)

Controllers Connected to a Personal Computer with a Pulse Generating Board

Problem

Personal Computer for Factory Automation

Touch Panel for Operation

- Significant installation space and wiring costs are required as a pulse-train interface is used.
- Status data for servo drives and parameters cannot be transferred to the controller.
- Execution timing is often out of sync because applications are MS Windows-based programs.

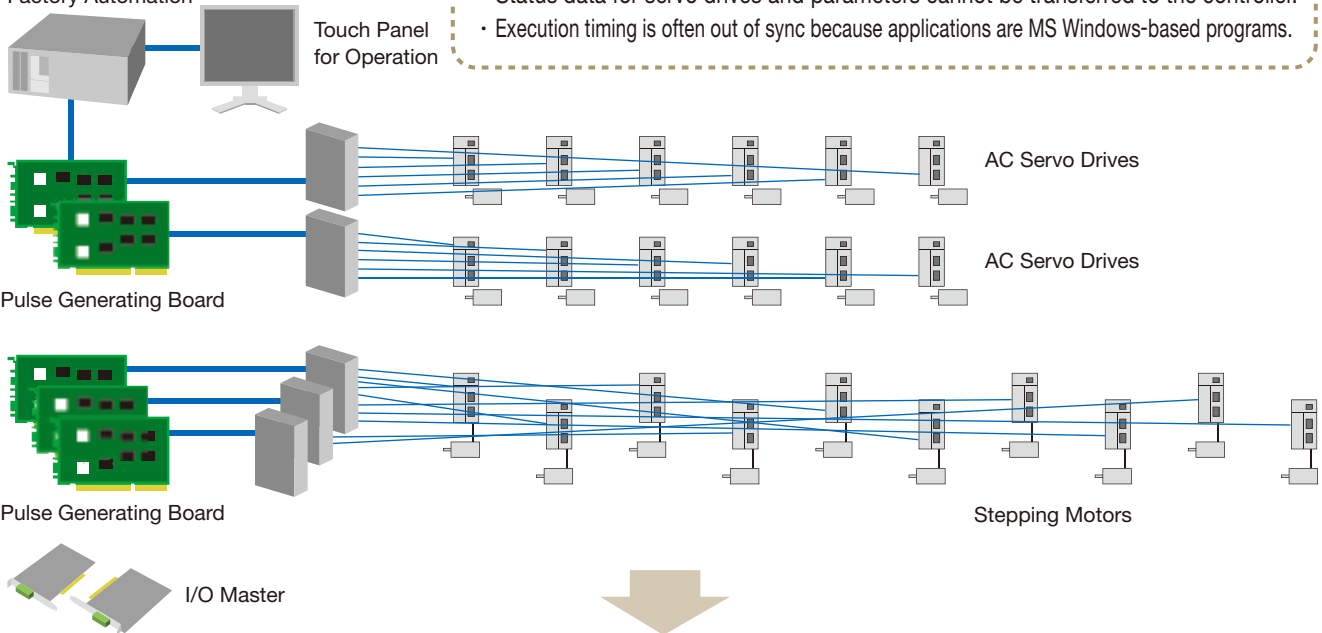

Advantage of the MP2000 Series Machine Controllers

Personal Computer for Factory Automation

Touch Panel for Operation

- The MP2101TM can control 32 axes (2 ports, 16 axes/port) and supports MECHATROLINK-III communications.
- The scanning time is 500 μ s at maximum speed, and the transmission cycle is 250 μ s for 7 axes.
- Synchronized control of up to 32 axes.
- No additional power source is required, because the power is supplied from the computer. The power can be supplied consistently for an extended period of time.
- Application programs are executed in the board, and are compatible with MP2200 and MP2300S machine controllers.

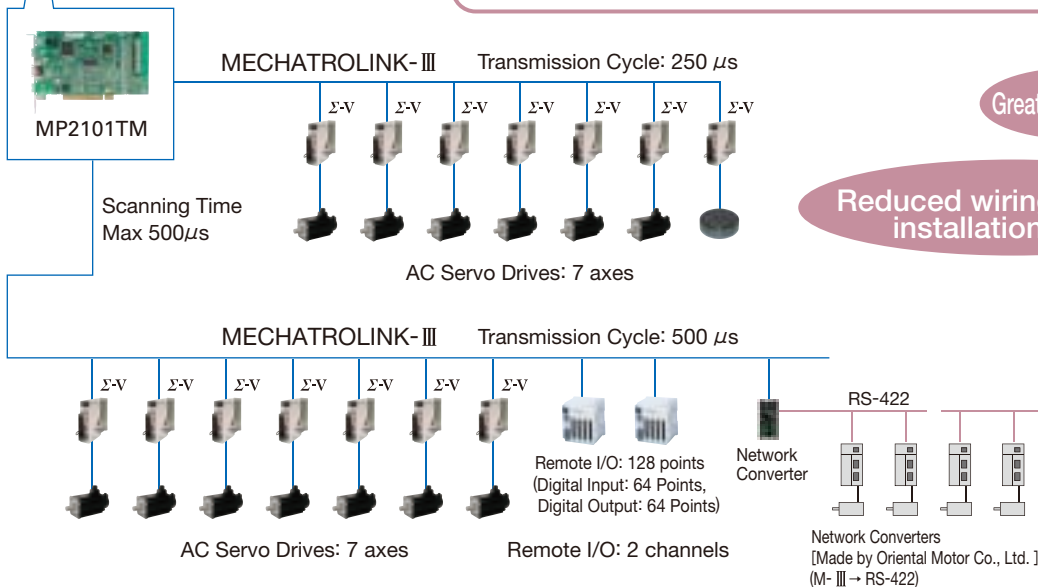

Great performance

Reduced wiring, cost and installation space

System Configurations

Note: For examples of system configurations using MECHATROLINK-III, see pages 39.
For examples of system configurations if using the MP2300S and the MP2400, see pages 24 and 25.

MECHATROLINK-II System Configuration for MP2200

An example of how the optional module can be connected is shown. Each connection is marked by a number. Refer to that number in the table to see the cable specifications for that specific connection.

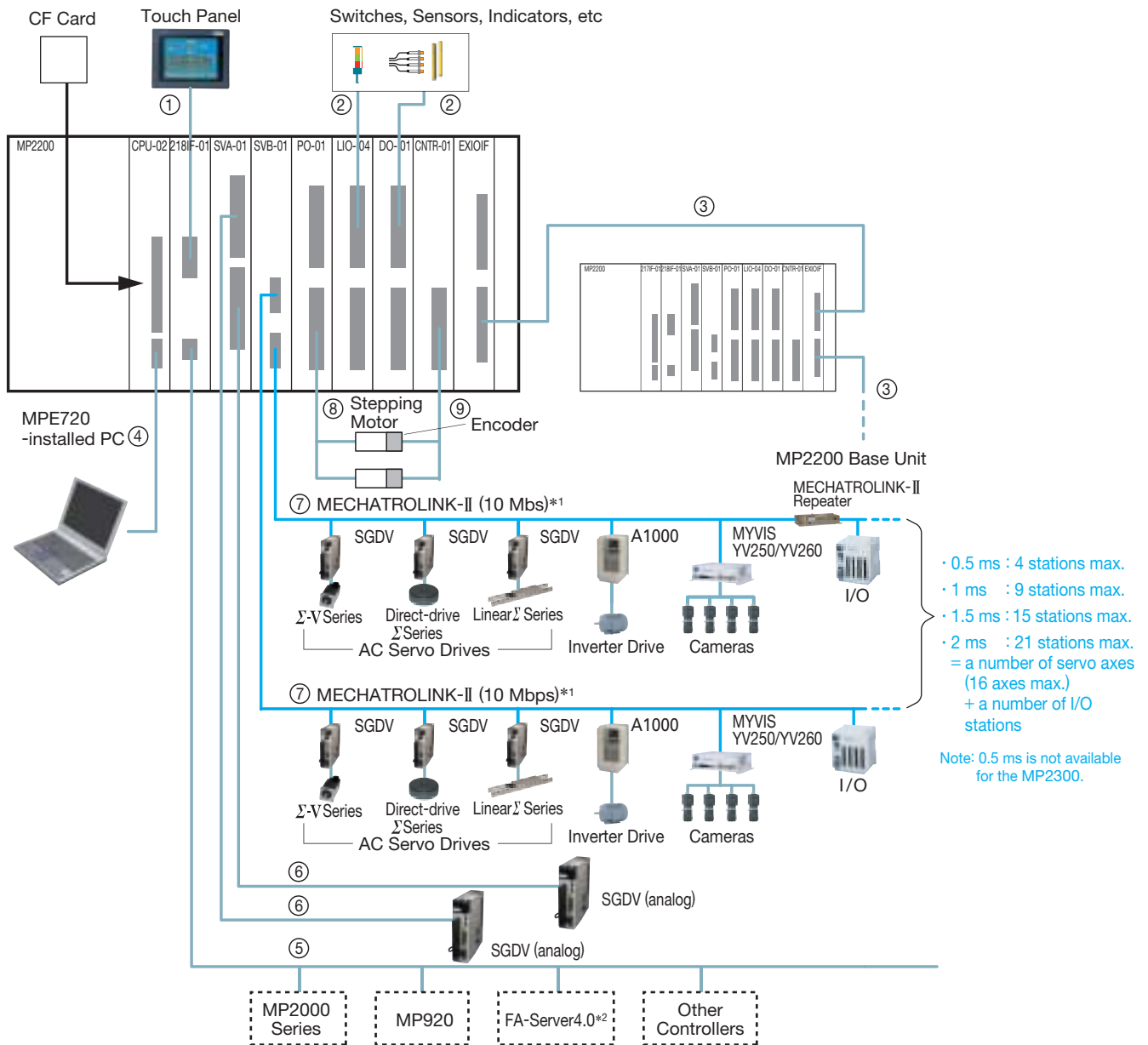

*1 : A Repeater (model: JEPMC-REP2000) is required when 17 or more slave stations are connected by MECHATROLINK-II communications.
*2 : Can be connected to the OPC server such as FA-Server4.0 (made by Roboticsware, Inc.) to monitor the data via the 218IF-01 Ethernet port. Contact Roboticsware, Inc. for more information (<http://www.roboticsware.co.jp/index.htm>).

Names and Models of Cables

No.	Name	Model	Length m
①	RS-232C Communication Cable	JEPMC-W5311-□□-E	2.5 / 15.0
②	I/O Cable for LIO-04 and DO-01	JEPMC-W6060-□□-E	0.5 / 1.0 / 3.0
③	EXIOIF Cable	JEPMC-W2091-□□-E	0.5 / 1.0 / 2.5
④	USB Cable	Use a USB cable.	
⑤	Ethernet Communication Cable	Use 10BASE-T cross or straight cables.	
⑥	Connection Cable for SVA-01	JEPMC-W2040-□□-E	0.5 / 1.0 / 3.0
		JEPMC-W2041-□□-E	0.5 / 1.0 / 3.0
⑦	MECHATROLINK-II Cable	JEPMC-W6002-□□-E	0.5 / 1.0 / 3.0 / 5.0 / 10.0 / 20.0 / 30.0 / 40.0 / 50.0
		JEPMC-W6003-□□-E	0.5 / 1.0 / 3.0 / 5.0 / 10.0 / 20.0 / 30.0 / 40.0 / 50.0
⑧	I/O Cable for PO-01	JEPMC-W6060-□□-E	0.5 / 1.0 / 3.0
⑨	I/O Cable for CNTR-01	JEPMC-W2063-□□-E	0.5 / 1.0 / 3.0

System Configurations (Cont'd)

MECHATROLINK-II System Configuration for MP2500M

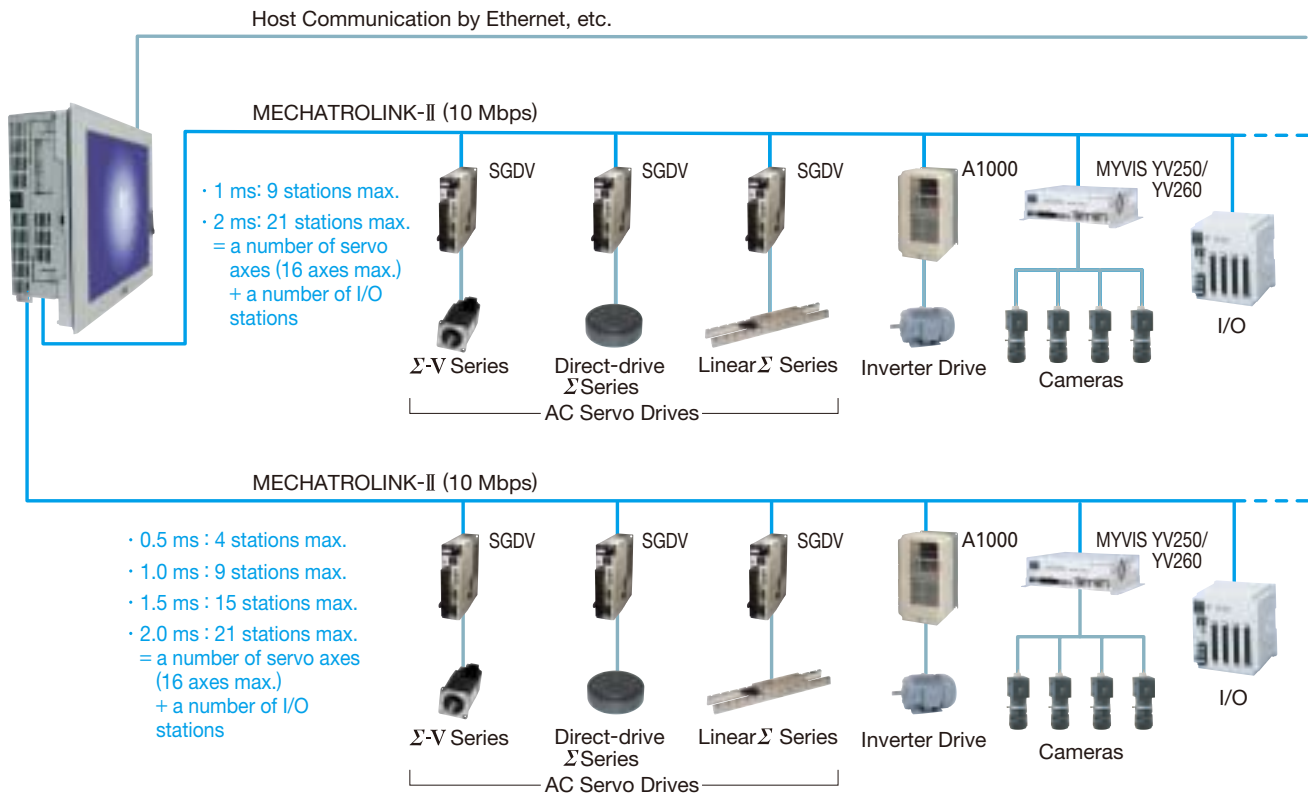

MECHATROLINK-II System Configuration for MP2100M

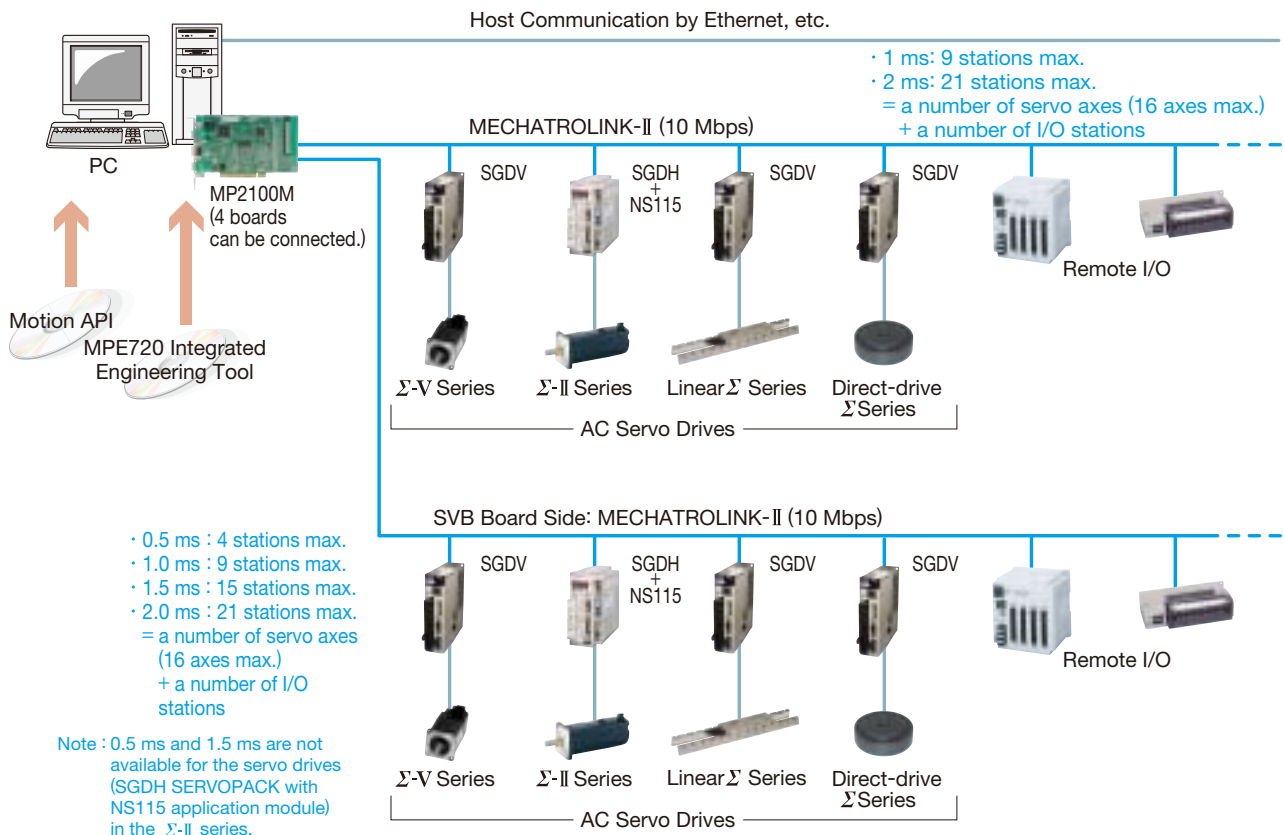

MECHATROLINK-III System Configuration for MP2200

An example of how the optional module can be connected is shown. Each connection is marked by a number. Refer to that number in the table to see the cable specifications for that specific connection.

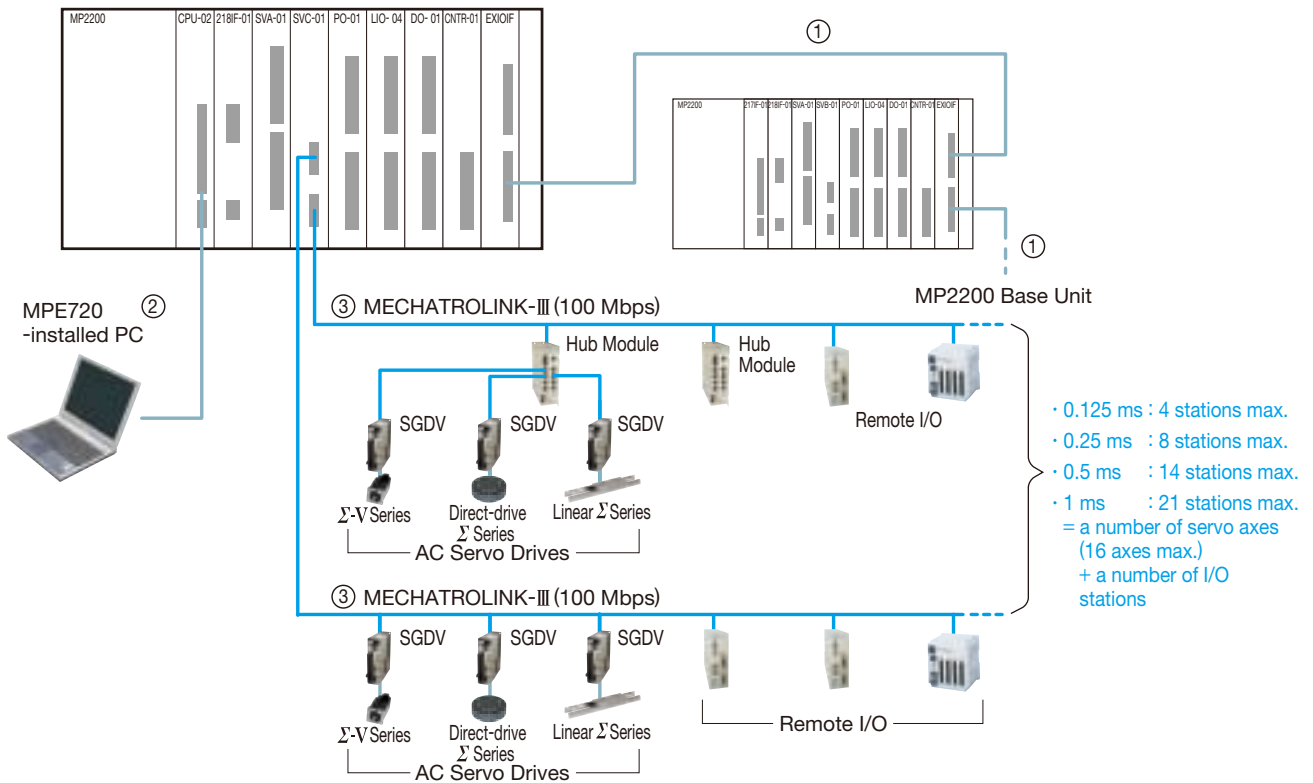

Names and Models of Cables

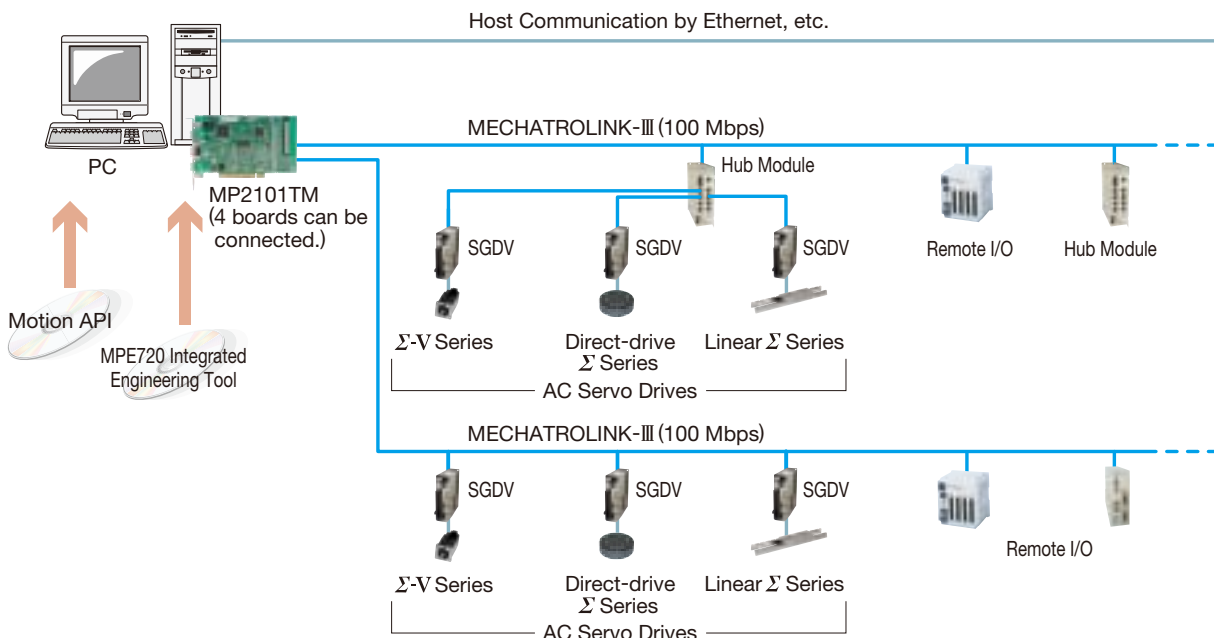

No.	Name	Model	Length m
①	EXIOIF Cable	JEPMC-W2091-□□-E	0.5 / 1.0 / 2.5
②	USB Cable	Use a USB cable.	
③	MECHATROLINK-III Cable	JEPMC-W6012-□□-E	0.2 / 0.5 / 1.0 / 2.0 / 3.0 / 4.0 / 5.0 / 10 / 20 / 30 / 50
		JEPMC-W6013-□□-E	10 / 20 / 30 / 50 / 75
		JEPMC-W6014-□□-E	0.5 / 1.0 / 3.0 / 5.0 / 10 / 30 / 50

MECHATROLINK-III System Configuration for MP2101TM







Hardware Specifications

Specifications

Controller		MP2100 (M) MP2101 (M) MP2101T (M) 	MP2200 	
Controller Type		Board Type	Module Type	
Speed Comparison of CPU Module (when compared to the MP2300)		1.5	1.5 to 3.0 (CPU-01/02/03/04)	
Minimum Scanning Time		MP2100: 1.0 ms MP2100M: 0.5 ms MP2101 (M): 0.5 ms MP2101T (M): 0.5 ms	0.5 ms	
Number of Controlled Axes		16/32 axes	256 axes	
Available User Program Memory		5.5 MB/11.5 MB	7.5 MB/11.5 MB	
Built-in CPU Functions	Motion Control	M-II, M-III	Special orders only	
	Host Controller Interface	–	Ethernet (100 Mbps) (Only available for CPU-03 and CPU-04)	
	I/O	Digital Input: 5 points, Digital Output: 4 points	–	
Programming	Ladder Language	●	●	
	Motion Language	●	●	
	API	●	–	
Control Functions	Control for Positioning, Speed and Torque	●	●	
	Interpolation Control	●	●	
	Phase Control	●	●	
	Electronic Cam and Shaft Control	●	●	
Motion Control Interface	M-II	● MP2100 (M), MP2101 (M)	● (Special orders only)	
	M-III	● MP2101T (M)	● (Special orders only)	
	Pulse Train	–	● (Special orders only)	
	Analog Voltage	–	● (Special orders only)	

Note: M-II stands for MECHATROLINK-II and M-III for MECHATROLINK-III.

	MP2300	MP2310	MP2300S	MP2400	MP2500
					
	All-in-one Type			Compact Unit Type	Panel Type
	1.0	1.5	1.5	1.5	1.5
	1.0 ms	0.5 ms	0.5 ms	1.0 ms	MP2500: 1.0 ms MP2500M: 0.5 ms
	48 axes	64 axes	32 axes	16 axes	16/32 axes
	5.5 MB	7.5 MB	5.5 MB	5.5 MB	5.5 MB
	M-II	M-II	M-II	M-II	M-II
	–	Ethernet (100 Mbps)	Ethernet (100 Mbps)	Ethernet (100 Mbps)	–
	Digital Input: 8 points, Digital Output: 4 points	–	–	–	Digital Input: 5 points, Digital Output: 4 points
	●	●	●	–	●
	●	●	●	●	●
	–	–	–	–	●
	●	●	●	●	●
	●	●	●	●	●
	●	●	●	–	●
	●	●	●	–	●
	●	●	●	●	●
	● (Special orders only)	● (Special orders only)	● (Special orders only)	–	–
	● (Special orders only)	● (Special orders only)	● (Special orders only)	–	–
	● (Special orders only)	● (Special orders only)	● (Special orders only)	–	–

Hardware Specifications

General Specifications [MP2000 Series excluding MP2500 (B) and MP2500M (B)]

Items		Specifications	Items		Specifications
Environmental Conditions	Ambient Operating Temperature	0°C to +55°C*	Mechanical Operating Conditions	Vibration Resistance	Conforming to JIS B3502
	Ambient Storage Temperature	-25°C to +85°C			• Frequency: 16.7 Hz
	Ambient Operating Humidity	30% to 95%RH (non-condensing)			Vibration acceleration: 14.7 m/s ²
	Ambient Storage Humidity	5% to 95%RH (non-condensing)		2 hours in each direction (X, Y, and Z)	
	Pollution Level	1 (Conforming to JIS B3501)		• Frequency: 10 Hz to 57 Hz	
	Corrosive Gas	No combustible or corrosive gas		Vibration amplitude: Single-amplitude of 0.075 mm	
Electrical Operating Conditions	Noise Resistance	Conforming to EN61000-6-2, EN55011 (Group 1, Class A)	Shock Resistance	• Frequency: 57 Hz to 150 Hz	Vibration acceleration: a fixed acceleration of 9.8 m/s ²
		Power supply noise (FT noise): 2 kV or larger for 1 min.		Peak acceleration of 147 m/s ² (15 G) twice for 11 ms in each direction (X, Y, and Z)	
		Radiation noise (FT noise): 1 kV or larger for 1 min.	Installation Requirements	Ground	Ground to 100Ω or less
			Cooling Method		Natural cooling

*: If using the PO-01 or CPU-03 module, an operating temperature of 0°C to +50°C is required.

Machine Controller Main Units

● MP2100 (M), MP2101 (M), MP2101T (M) Boards

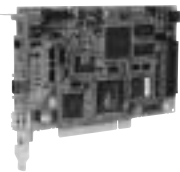

MP2100/MP2101 Board
Model: JAPMC-MC2100-E,
JAPMC-MC2102-E
Approx. Mass: 135 g



MP2100M/MP2101M Board
Model: JAPMC-MC2140-E,
JAPMC-MC2142-E
Approx. Mass: 210 g



MP2101T Board
Model: JAPMC-MC2102T-E
Approx. Mass: 150 g



MP2101TM Board
Model: JAPMC-MC2142T-E
Approx. Mass: 245 g

Items		Specifications					
		MP2100	MP2101	MP2100M	MP2101M	MP2101T	MP2101TM
Power Supply		Input supply voltage: 5 VDC ±5%					
Dimensions		106.69×174.63 mm (Half the size of a standard PCI)					
Motion Network	Network	MECHATROLINK-II				MECHATROLINK-III	
	Transmission Speed	10 Mbps				100 Mbps	
	Max. Number of Stations	Twenty-one stations, including servo drives and I/O equipment, can be connected per circuit. (16 axes for servo drives)					
	Number of Circuits	1		2		1	2
Available User Program Memory		5.5 MB	11.5 MB	5.5 MB	11.5 MB	11.5 MB	
I/O Signals		Digital input: 5 points (One point can be used for interrupts), 24 VDC, 4 mA, and source mode or sink mode input Digital output: 4 points, 24 VDC, 100 mA, open collector, and sink mode output					

■ Host Computer Specifications

Items		Specifications
Hardware	Model	PC/AT compatible (excluding NEC 9800 series)
	CPU	Pentium 200 MHz or more (Pentium 400 MHz or more recommended)
	Memory Capacity	64 MB or more
	Free Hard Space	500 Mbytes min.
	Display Resolution	800 × 600 or more (1024 × 768 recommended)
	Expansion Slot*1	Half the size of a standard PCI slot
	Interrupts*1	First-level use (IRQ sharing is possible.)
	I/O Memory*1	32 kB shared memory used
Software	OS*2	Windows 2000 Professional SP1 or later, Windows XP, Windows Vista, Windows 7
	Web Browser	Microsoft IE 5.5 SP2 or later
	Language	Microsoft Visual C/C++6.0 SP5 or later, Microsoft Visual Basic6.0 SP5 or later, Microsoft Visual C++ .NET2003, Microsoft Visual Basic .NET2003, Microsoft Visual C++ .NET2005, Microsoft Visual Basic .NET2005, Microsoft Visual C++ .NET2008, Microsoft Visual Basic .NET2008, Microsoft Visual C++ .NET2010, Microsoft Visual Basic .NET2010

*1: These specifications are applicable if using an MP2100, MP2101, or MP2101T board. If using two or more boards in the same host personal computer, the resources to which the number of boards was applied are needed for the above-mentioned specifications.

*2: Only 32-bit versions

● MP2200 Base Units



Model: JEPMC-BU2200-E
Approx. Mass: 665 g
Model: JEPMC-BU2210-E
Approx. Mass: 520 g



Model: JEPMC-BU2220-E
Approx. Mass: 500 g

Items	Specifications		
	JEPMC-BU2200-E (MBU-01)	JEPMC-BU2210-E (MBU-02)	JEPMC-BU2220-E (MBU-03)
Power Supply	Input power voltage: 85 VAC to 276 VAC Current consumption: 1.5 A or less with I/O rating Inrush current: 40 A or less when completely discharged, 275 VAC input, output rating Allowable power loss time: 20 ms	Input power voltage: 24 VDC ±20% Current consumption: 3.0 A or less with I/O rating Inrush current: 30 A or less when completely discharged, output rating Allowable power loss time: 1 ms	Input power voltage: 24 VDC ±20% Current consumption: 1.0 A or less with I/O rating Inrush current: 30 A or less when completely discharged, output rating Allowable power loss time: 1 ms
Motion Network	Not available for the base unit		
I/O Signals	Not available for the base unit		
Slot for Optional Modules	9 slots		4 slots
Expansion Configuration	Maximum of 4 base units can be connected using the EXIOIF.		
Dimensions (mm)	240 (W) × 130 (H) × 108 (D)		120 (W) × 130 (H) × 108 (D)

● MP2300 and MP2310 Basic Modules



Model: JEPMC-MP2300-E
Approx. Mass: 500 g



Model: JEPMC-MP2310-E
Approx. Mass: 500 g

Items	Specifications	
	MP2300	MP2310
Power Supply	Input power voltage: 24 VDC ±20% Inrush current: 40 A or less	Current consumption: 1 A Allowable power loss time: 2 ms
Motion Network	One circuit for MECHATROLINK-II: 21 stations, including servodrives and I/O devices, can be connected. (Maximum 16 axes for servodrives) Transmission speed: 10 Mbps (MECHATROLINK-II) Transmission distance: See "MECHATROLINK-II Repeater" on page 57.	
Communication Port	Not available for the basic module	Ethernet: 100BASE-TX/10BASE-T, 1 port
I/O Signals	Digital input: 8 points (One point can be used for interrupts), 24 VDC, 4 mA, and source mode or sink mode input Digital output: 4 points, 24 VDC, 100 mA, open collector, and sink mode output	Not available for the basic module
Slot for Optional Modules	3 slots	
Dimensions (mm)	120 (W) × 130 (H) × 108 (D)	

● MP2300S Basic Module



Model: JEPMC-MP2300S-E
Approx. Mass: 390 g

Items	Specifications	
Power Supply	Input supply voltage: 24 VDC ±20% Inrush current: 40 A	Current consumption: 1 A max. Allowable power loss time: 2 ms
Motion Network	One circuit for MECHATROLINK-II: 21 stations, including servodrives and I/O devices, can be connected. (Maximum 16 axes for servodrives) Transmission speed: 10 Mbps (MECHATROLINK-II) Transmission distance: See "MECHATROLINK-II Repeater" on page 57.	
Communications Port	Ethernet: 100BASE-TX/10BASE-T, one port	
I/O Signals	Input: None Output: CPU Ready status output (relay output)	
Slot for Optional Modules	1 slot	
Dimensions (mm)	64 (W) × 130 (H) × 108 (D)	

● MP2400



Model: JEPMC-MP2400-E
Approx. Mass: 350 g

Items	Specifications	
Power Supply	Input supply voltage: 24 VDC ±20% Inrush current: 40 A	Current consumption: 1 A max. Allowable power loss time: 2 ms
Motion Network	One circuit for MECHATROLINK-II: 21 stations, including servodrives and I/O devices, can be connected. (Maximum 16 axes for servodrives) Transmission speed: 10 Mbps (MECHATROLINK-II) Transmission distance: See "MECHATROLINK-II Repeater" on page 57.	
Communications Port	Ethernet: 100BASE-TX/10BASE-T, one port	
I/O Signals	Input: None Output: CPU Ready status output (relay output)	
Slot for Optional Modules	None	
Dimensions (mm)	45 (W) × 130 (H) × 108 (D)	

Hardware Specifications

● MP2500, MP2500M, MP2500B, MP2500MB



Panel-integrated type



Panel-separated type

Model : JEPMC-MP25□□-N□□-E

Board type (with PCI slot)

- 0 : Motion board with one MECHATROLINK-II port
- 4 : Motion board with two MECHATROLINK-II ports

Expansion board type (Option)

- 0 : Without expansion board
- E : EXIOIF (for panel-integrated type only)
- U : Optional module mounting unit (for panel-separated type only)

Panel computer specifications

- P0 : Panel-integrated type with 15-inch display screen
CPU: Celeron M, 1.86 GHz
Memory: 512 Mbytes
- P1 : Panel-integrated type with 12.1-inch display screen
CPU: Celeron M, 1.86 GHz
Memory: 512 Mbytes
- B0 : Panel-separated type
CPU: AMD Geode LX800, 500 MHz
Memory: 512 Mbytes

■ Electrical Specifications

Items		Panel Integrated: JEPMC-MP25□□-NP□-E	Panel Separated: JEPMC-MP25□□-NB0-E
Power Supply	Rated Voltage	100 V/240 VAC	24 VDC
	Allowable Voltage Range	85 VAC to 264 VAC	24 VDC ±10%
	Rated Frequency	50/60 Hz	-
	Allowable Frequency Range	47 Hz to 63 Hz	-
	Allowable Momentary Power Loss Time	1 cycle max. (Interval are 1 s or more.)	-
	Power Consumption	145 VA max.	23 W max.
	Inrush Current	40 A max.	1 A max.
Dielectric Strength		1500 VAC 20 mA for one minute (between live part terminal and FG terminal)	-
Insulation Resistance		500 VDC 10 MΩ min. (between live part terminal and FG terminal)	-

■ Environmental Specifications

Items		Panel Integrated: JEPMC-MP25□□-NP□-E	Panel Separated: JEPMC-MP25□□-NB0-E Optional Panel for Separated Panel: JEPMC-OP25PNL-□□-E
Physical Environment	Ambient Operating Temperature	0°C to +50°C	0°C to +40°C
	Ambient Storage Temperature	-20°C to +60°C	-10°C to +50°C
	Ambient Operating /Storage Humidity	10% to 90%RH (with no condensation)	30% to 85%RH (with no condensation)
	Dust	There must be no dust.	There must be no dust.
	Corrosive Gas	There must be no corrosive gas.	There must be no corrosive gas.
Mechanical Operation Conditions	Vibration Resistance	Compliance with JIS B 3502, IEC/EN 61131-2. 5 Hz to 9 Hz : Single amplitude of 3.5 mm 9 Hz to 150 Hz : A constant acceleration of 9.8 m/s ² In each X, Y and Z direction 10 cycle 100 min. each	Compliance with JIS B 3502. Vibration amplitude and acceleration · 10 Hz ≤ Frequency < 57 Hz : Single amplitude of 0.075 mm · 57 Hz ≤ Frequency < 150 Hz : A constant acceleration of 9.8 m/s ² In each X, Y, and Z direction Sweep rate (1 octave/min) × number of sweeps (10)
Electrical Operation Conditions	Noise Resistance	Voltage noise : 1500 V _{P-P} Pulse width : 50 ns, 500 ns, 1μs Rise time : 1 ns (Noise simulator)	Compliance with EN55011 Group 1 Class A Power supply noise (FT noise) : 2 kV or larger for 1 min. Radiation noise (FT noise) : 1 kV or larger for 1 min.
	Electrostatic Resistance Discharging	Contact discharge method 6 kV (IEC/EN 61000-4-2 level 3)	Compliance with EN 61000-4.2 ±6 kV (direct contact) , ±8 kV (under ground)

■ Structural Specifications

Items	Panel Integrated: JEPMC-MP25□□-NP□-E	Panel Separated: JEPMC-MP25□□-NB0-E	Optional panel for Separated Panel: JEPMC-OP25PNL-□□-E
Ground	Protective ground: Ground to 100 Ω max. Functional ground: Ground to 100 Ω max.	Protective ground: Ground to 100 Ω max. Functional ground: Ground to 100 Ω max.	
Protective Structure and Installation	Protected structure: Equivalent to IP65* (Applicable to the front side of the panel when embedded and only when the front USB is not used.) Installation method: Embedded	Installation method: Installation without embedding	Installation method Installation with a PC box: Embedded When only a panel: Embedded

Cooling Method	Cooling fans	Self-cooling	
Mass	15-inch model JEPMC-MP25□□-NP0-E: 12 kg	Without optional slot: 1.9 kg	10.4-inch panel JEPMC-OP25PNL-10-E: 1.82 kg
	12-inch model JEPMC-MP25□□-NP1-E: 8 kg	With optional slot: 2.1 kg	12.1-inch panel JEPMC-OP25PNL-12-E: 2.2 kg

* : The degree of protection applies to the front of the product when it is installed in a solid panel. Although the front of the product has been tested under conditions equivalent to those listed in the specifications, this does not mean that the product will meet these specifications under all conditions. Before installing the product, check the product's performance under conditions that will reflect its actual operating environment.

■ Hardware Specifications

Items		Panel Integrated: JEPMC-MP25□□-NP□-E	Panel Separated: JEPMC-MP25□□-NB0-E
Panel Computer	Display	15-inch XGA TFT 1024×768, 12.1-inch SVGA 800×600	12.1-inch SVGA 800×600, 10.4-inch SVGA 800×600
	CPU	Celeron M 440, 1.86 GHz	AMD Geode LX800, 500 MHz
	Main Memory	512 Mbytes	512 Mbytes
	Disk	CF card: 2 Gbytes, Free space: approx. 700 Mbytes	CF card: 2 Gbytes, Free space: approx. 700 Mbytes
	Video Memory	64 Mbytes, 260,000 colors	64 Mbytes, 260,000 colors
	Serial	RS-232C: 4 ports (One of these ports can be used to switch to RS-422/RS485)	Option: Two RS-232C ports
	USB	USB: 5 ports (1 on the front, 4 on the back)	USB: 4 ports
	LAN	10/100BASE: 1 channel, 10/100/1000BASE: 1 channel, automatic switching	10/100BASE: 1 channel
	Sound	Speaker output: 1 port	Speaker output: 1 port
	Expansion Slot	One spare PCI slot	No spare slot
	Compatible OS	WindowsXP Embedded	WindowsXP Embedded
	Ambient Operating Temperature	0 to +50°C	0 to +40°C
	Operating Environment	IP65	—
	Power Supply	100/240 VAC (50/60 Hz)	24 VDC
	Cooling Method	Cooling fan	Natural cooling
Motion Board	Diagnostic Functions	RAS (Reliability, Availability, and Serviceability) functions (power supply voltage, cooling fan, watchdog, touch panel, etc.)	—
	Motion Network	MECHATROLINK-II (One circuit with MP2500/MP2500M, two circuits with MP2500M/MP2500MB) Up to 21 stations, including servo drives and I/O devices, can be connected per circuit. (16 axes max. for servo drives)	
	I/O Signals	Digital input : 5 points (one of these is also used for interrupt.), 24 VDC, 4 mA Digital output : 4 points, 24 VDC, 100 mA, open-collector, and sink mode output	

CPU Module Applicable Models: 

● MP2200 CPU Module (CPU-01/CPU-02/CPU-03/CPU-04/MPU-01)

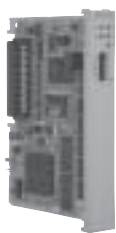

CPU-01 Module
Model: JAPMC-CP2200-E
Approx. Mass: 66 g



CPU-02 Module
Model: JAPMC-CP2210-E
Approx. Mass: 75 g



CPU-03 Module
Model: JAPMC-CP2220-E
Approx. Mass: 86 g



CPU-04 Module
Model: JAPMC-CP2230-E
Approx. Mass: 86 g



MPU-01 Module
Model: JAPMC-CP2700-E
Approx. Mass: 86 g

Items	Specifications				
	CPU-01	CPU-02	CPU-03	CPU-04	MPU-01
Max. Number of Controlled Axes	256 axes				16 axes
High-speed Scan	0.5 ms to 32.0 ms (in units of 0.5 ms)				0.25 ms, 0.5 ms to 32.0 ms (in units of 0.5 ms)
Low-speed Scan	2.0 ms to 300.0 ms (in units of 0.5 ms)				2.0 ms to 300.0 ms (in units of 0.5 ms)
User Memory Capacity	7.5 Mbytes	11.5 Mbytes		11.5 Mbytes	
Expansion Ports	—	1 slot for Compact Flash card		—	—
		1 port for USB	1 port for Ethernet		—

Notes: 1 Not applicable to multiple CPU system
2 An MPU-01 module must be used with an MP2000 board [MP2100M, MP2101(M), or MP2101T(M)] or a CPU module with a built-in Ethernet port (MP2310, MP2300S, CPU-03, or CPU-04).

Connection Module

● Expansion Interface Module (EXIOIF)



Applicable Model: 

Items	Specifications
Number of Expansion Racks	4 racks max.
Rack No.	Automatically identified

Model: JAPMC-EX2200-E
Approx. Mass: 80 g

● Expansion Interface Board (MP2100MEX)



Applicable Model:  

Items	Specifications
Number of Expansion Racks	3 racks max.
Rack No.	Automatically identified
Current Consumption	Approx. 650 mA at 5 V supplied by PCI bus.

Model: JAPMC-EX2100-E
Approx. Mass: 90 g

Communication Modules

Applicable Models:    

● General-purpose Serial Communication Module (217IF-01)



Model: JAPMC-CM2310-E
Approx. Mass: 100 g

■ For RS-232C Communication

Items	Specifications
Interface	One port
Connector	D-sub 9 pins (Female)
Max. Transmission Distance	15 m
Max. Transmission Speed	76.8 kbps
Access Mode	Asynchronous (Start-stop synchronization)
Communication Protocols	MEMOBUS (Master or Slave), MELSEC (A-compatible 1C frame, type:1), OMRON (only for host mode), Non-procedure
Media Access Control Method	1:1
Transmission Format (Can be set)	Data bit length: 7 or 8 bits Stop bits: 1 or 2 bits Parity bits: Even, odd, or none

■ For RS-422/485 Communication

Items	Specifications
Interface	One port (RS-422 or -485)
Connector	MDR 14 pins (Female)
Max. Transmission Distance	300 m
Max. Transmission Speed	76.8 kbps
Access Mode	Asynchronous (Start-stop synchronization)
Communication Protocols	MEMOBUS (Master or Slave), MELSEC (A-compatible 1C frame, type:1), OMRON (only for host mode), Non-procedure
Media Access Control Method	1:1 (RS-422), 1: N (RS-485)
Transmission Format (Can be set)	Data bit length: 7 or 8 bits Stop bits: 1 or 2 bits Parity bits: Even, odd, or none

● Ethernet Communication Module (218IF-01/02)



218IF-01 Module
Model: JAPMC-CM2300-E
Approx. Mass: 90 g

■ For Ethernet Communication

Items	Specifications
Interface	One port (10BASE-T for 218 IF-01, 100BASE-TX/10BASE-T for 218 IF-02) (RJ-45 modular jack)
Max. Segment Length	100 m
Transmission Speed	218IF-01: 10 Mbps, 218IF-02: 100 Mbps/10 Mbps
Access Mode	IEEE802.3
Connections	TCP/UDP/IP/ARP/ICMP
Max. Number of Words in Transmission	218IF-01: 510 words, 218IF-02: 2044 words
Communication Protocols	Extended MEMOBUS, MEMOBUS, MELSEC (A-compatible 1C frame, type:1), Non-procedure, MODBUS/TCP
Max. Number of Connections	20 stations



218IF-02 Module
Model: JAPMC-CM2302-E
Approx. Mass: 90 g

■ For RS-232C Communication

Items	Specifications
Interface	One port
Connector	D-sub 9 pins (Female)
Max. Transmission Distance	15 m
Max. Transmission Speed	19.2 kbps (Using 218IF-01), 115.2 kbps (Using 218IF-02)
Access Mode	Asynchronous (Start-stop synchronization)
Communication Protocols	MEMOBUS (Master or Slave), MELSEC (A-compatible 1C frame, type:1), OMRON (only for host mode), Non-procedure
Media Access Control Method	1:1
Transmission Format (Can be set)	Data bit length: 7 or 8 bits Stop bits: 1 or 2 bits Parity bits: Even, odd, or none

● DeviceNet Communication Module (260IF-01)



Model: JAPMC-CM2320-E
Approx. Mass: 90 g

■ For DeviceNet Communication

Items	Specifications	
Number of Circuits	1	
Applicable Communication	Conforms to DeviceNet · I/O transmission (polled I/O and bit-strobed I/O) · Explicit messaging	
I/O Communication	Max. Number of Slaves	63 nodes
	Max. I/O Bytes	1024 bytes, 256 bytes per node
Message Communication (Only for Master)	Max. Number of Nodes	63 nodes Synchronous communications possible: 8 nodes
	Max. Message Length	256 bytes
	Executed Functions	MSG-SND function
Switches on the Front	Two rotary switches: Node address settings DIP switch: Settings for transmission speed and switching master or slave	
Indicators	2 LEDs: MS and NS	
Power Voltage for Communication	24 VDC \pm 10% (Using the specially designed cable)	
Max. Current Consumption	Communication power: 45 mA (Supplied by transmission connectors)	

■ For RS-232C Communication

Items	Specifications
Interface	One port
Connector	D-sub 9 pins (Female)
Max. Transmission Distance	15 m
Max. Transmission Speed	19.2 kbps
Access Mode	Asynchronous (Start-stop synchronization)
Communication Protocols	MEMOBUS (Master or Slave), MELSEC (A-compatible 1C frame, type:1), OMRON (only for host mode), Non-procedure
Media Access Control Method	1:1
Transmission Format (Can be set)	Data bit length: 7 or 8 bits Stop bits: 1 or 2 bits Parity bits: Even, odd, or none

Hardware Specifications

● PROFIBUS Communication Module (261IF-01)



Model: JAPMC-CM2330-E
Approx. Mass: 90 g

■ For PROFIBUS Communication

Items	Specifications
Functions	DP slave, Cyclic communication (DP standard function)
Transmission Speed	12 M/6 M/4 M/3 M/1.5 M/750 k/500 k/187.5 k/93.75 k/19.2 k/9.6 kbps (Automatic detection)
Configuration	By PROFIBUS Master
Slave Address	1 to 64
I/O Processing	Total capacity of IW/OW registers: 64 words Max. I/O allocation (IN and OUT each): 64 words
Diagnostic Functions	Display for status and slave status using the EWS. I/O error display for SW registers.

■ For RS-232C Communication

Items	Specifications
Interface	One port
Connector	D-sub 9 pins (Female)
Max. Transmission Distance	15 m
Max. Transmission Speed	19.2 kbps
Access Mode	Asynchronous (Start-stop synchronization)
Communication Protocols	MEMOBUS (Master or Slave), MELSEC (A-compatible 1C frame, type:1), OMRON (only for host mode), Non-procedure
Media Access Control Method	1:1
Transmission Format (Can be set)	Data bit length: 7 or 8 bits Stop bits: 1 or 2 bits Parity bits: Even, odd, or none

● FL-net Communication Module (262IF-01)



Model: JAPMC-CM2303-E
Approx. Mass: 80 g

■ For 262IF-01 Communication

Items		Specifications		
FL-net Transmission	Transmission Specifications*1	Interface	100BASE-TX 10BASE-T	
		Transmission Mode	Full duplex or half duplex	
		Transmission Speed	100 Mbps 10 Mbps	
		Max. Segment Length	100 m between hub and nodes if UTP cables are used	
		Connector	RJ-45 connector	
		Auto Negotiation	Supported (Transmission speed and communication mode cannot be fixed.)	
	Cyclic Communication Specifications	Max. Number of Nodes	254 nodes max. if repeaters are used (Only 64 nodes, including the local node, can be allocated.)*2	
		Data Size	Max. data size within network Area 1 (Bit data) : 8 kbits Area 2 (Word data) : 8 kwords Max. data size per station (node) Area 1 + Area 2 : 8 kbits + 8 kwords can be allocated.	
		Media Access Control Method	N : N	
	Message Communication Specifications	Number of Message Channels	10	
		Engineering Communication	None	
		Message Service	Read Word Block, Write Word Block, Read Network Parameter, Write Network Parameter*3, Change Other Node to Stop Mode*3, Change Other Node to Run Mode*3, Read Profile, Transmissive Message, Read Log Data, Clear Log Data, Return Message	
		Number of Transmission Words	512 words max.	

*1 : Conforms to Ethernet specifications

*2 : The number of nodes that the 262IF-01 can allocate to I/O is limited to 64, including the local node, in accordance with the specifications of the MP series Machine Controllers.

*3 : Supported by client nodes only. (In FL-net communications, the node sending data is called the client, and the node receiving data is called the server.)

● EtherNet / IP Communication Module (263IF-01)



Model: JAPMC-CM2304-E
Approx. Mass: 80 g

■ For 263IF-01 Communication

Items		Specifications		
EtherNet / IP Transmission	Transmission Specifications*1	Interface	100BASE-TX 10BASE-T	
		Transmission Mode	Full duplex or half duplex	
		Transmission Speed	100 Mbps 10 Mbps	
		Max. Segment Length	100 m between hub and nodes if UTP cables are used	
		Connector	RJ-45 connector	
		Auto Negotiation	Supported (Transmission speed and communication mode cannot be fixed.)	
	I/O Communication Specifications	Max. Number of Connectable I/O Devices	64 units (Does not include the devices used for explicit message communication)*2	
		Max. Number of I/O Bytes	Max. Number of I/O Bytes within the network Inputs/outputs : 8192 bytes each per system (Total number of bytes of I/O data exchanged among all connected devices) Inputs/outputs : 500 bytes each per device	
		Communication Mode	Scanner and adapter	
	Explicit Message Communication Specifications	Max. Number of Connectable Devices for Explicit Message Communication	64 units (Number of devices that can communicate simultaneously : 10)*2	
		Number of Message Channels	10	
		Max. Number of Message Bytes	504 bytes	
		Communication Mode	Client and server	
		Connection Type	Unconnected type (UCMM) When the module functions as a server, connected type (class 3) is also supported.	

*1 : Conforms to Ethernet specifications

*2 : Max. Number of connectable devices is based on the specifications of the MP series Machine Controllers.

● EtherCAT Communication Module (264IF-01)



Model : JAPMC-CM2305-E
Approx. Mass : 100 g

■ For 264IF-01 Communication

Items		Specifications		
EtherCAT Transmission	Transmission Specifications	Transmission Mode	Full duplex	
		Transmission Speed	100 Mbps	
		Distance between Nodes	100 m	
		Connector	RJ-45 connector, 2 ports (1 circuit)	
		Cable	CAT 5e STP cable Straight or cross cable	
		Topology	Line topology (structure)	
		Functions	As a slave station of EtherCAT	
		Address	Automatic allocation by Master	
	Process Data Communications (Cyclic)	Supported Protocol	EtherCAT standard (Protocols such as CoE, SoE, and VoE are not supported.)	
		Data Size	Input data : 198 words max. Output data : 198 words max. Input data + Output data : 200 words max. in total	
		Media Access Control Method	Between master and slave (1 : 1)	
		Communication Cycle	According to the configuration of Master	
	Mailbox Communication (Message)	Supported Protocol	EtherCAT standard (Protocols such as CoE, EoE, FoE, SoE, and VoE are not supported.)	
		Message Service	System message only (Cannot use user messages such as read/write memory.)	

Hardware Specifications

● CompoNet Communication Module (265IF-01)



Model: JAPMC-CM2390-E
Approx. Mass: 80 g

■ For CompoNet Communication

Items		Specifications
Number of Circuits		1
Applicable Communication		I/O communication, message communication
Transmission Speed		4 Mbps, 3 Mbps, 1.5 Mbps, 93.75 kbps
Master/Slave		Master
Conditions of Use for Repeater Units		Up to 64 units can be connected in one network. Lines can be extended a maximum of two levels from the master unit using repeater units.
I/O Communication	Max. Number of Slaves	384 nodes
	Max. I/O Bytes	32 bytes per node
Message Communication	Max. Number of Nodes	384 nodes
	Max. Message Length	Synchronous communications possible: 10 nodes 256 bytes
	Executed Functions	MSG-SND function
Switches on the Front		DIP switch: Transmission speed
Indicators		4 LEDs: MS, NS, TX, RX
Power Voltage for Communication		24 VDC ±10% (Using the specially designed cable)

● PROFINET Communication Master Module (266IF-01)*



Model: JAPMC-CM2306-E
Approx. Mass: 100 g

■ For PROFINET Communication

Items		Specifications
Real-time Class		Class 1 and class 2
PROFINET IO Conformance Class		Class A
Transmission Speed		100 Mbps
Max. Transmission Distance		100 m/segment (between nodes)
Max. Number of Connecting Stations		128
Communication Cycle		1, 2, 4, 8, 16, 32, 64, 128, 256, or 512 (unit: ms)
Max. Transmission Size		1024 bytes/station Input: 5712 bytes; Output: 5760 bytes

*: Estimates are required before ordering this product. Contact your Yaskawa representative for more information.

● PROFINET Communication Slave Module (266IF-02)



Model: JAPMC-CM2307-E
Approx. Mass: 100 g

■ For PROFINET Communication

Items		Specifications
Real-time Class		Class 1, class 2, and class 3
PROFINET IO Conformance Class		Class A
Transmission Speed		100 Mbps
Max. Transmission Distance		100 m/segment (between nodes)
Max. Number of Connecting Stations		–
Communication Cycle		Same as master module
Max. Transmission Size		Input: 512 bytes; Output: 512 bytes

● MPLINK Communication Module (215AIF-01 MPLINK)

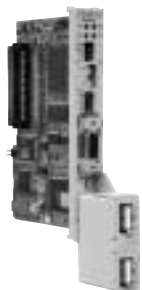

Model: JAPMC-CM2360-E
Approx. Mass: 130 g

■ For MPLINK Communication

Items	Specifications
Transmission Method	MPLINK
Interface	One port
Connector	USB port with T-branch connector*
Cable	MECHATROLINK cable (JEMPC-W6002-□□)
Transmission Speed	10 Mbps
Max. Transmission Distance	50 m: 16 stations 100 m: 32 stations (With MECHATROLINK-II JEMPC-REP2000 repeater)
Max. Number of Words in Link Transmission	4096 words per circuit. 1024 words per station.
Media Access Control Method	N : N
Max. Number of Connecting Stations	16 stations (32 stations with repeater)
Relay Function	Available

*: A T-branch connector is included in the package. Spares can also be ordered separately. (Model: JEMPC-OP2310-E)

■ For RS-232C Communication

Items	Specifications
Interface	One port
Connector	D-sub 9 pins (Female)
Max. Transmission Distance	15 m
Max. Transmission Speed	19.2 kbps
Access Mode	Asynchronous (Start-stop synchronization)
Communication Protocols	MEMOBUS (Master or Slave), MELSEC (A-compatible 1C frame, type:1), OMRON (only for host mode), Non-procedure
Media Access Control Method	1:1
Transmission Format (Can be set)	Data bit length: 7 or 8 bits Stop bits: 1 or 2 bits Parity bits: Even, odd, or none

● CP-215 Communication Module (215AIF-01 CP-215)

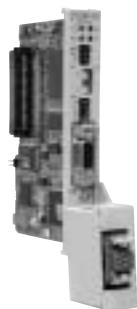

Model: JAPMC-CM2361*1
Approx. Mass: 130 g

■ For CP-215 Communication

Items	Specifications
Transmission Method	CP-215
Interface	One port
Connector	USB port with MR connector converter*2
Cable	No ready-made cable available. See page 85 for details on cable specifications.
Transmission Speed	2 Mbps / 4 Mbps
Max. Transmission Distance	270 m at 2 Mbps and 170 m at 4 Mbps.
Max. Number of Words in Link Transmission	2048 words per circuit. 512 words per station.
Media Access Control Method	N : N
Max. Number of Connecting Stations	32 stations (64 stations with repeater)
Relay Function	Available

*1 : Cannot be mounted in the slot to the left of 260IF-01. JAPMC-CM2361 modules cannot be mounted side by side.

*2 : An MR connector converter is included in the package. Spares can also be ordered separately. (Model: JEMPC-OP2320)

■ For RS-232C Communication

Items	Specifications
Interface	One port
Connector	D-sub 9 pins (Female)
Max. Transmission Distance	15 m
Max. Transmission Speed	19.2 kbps
Access Mode	Asynchronous (Start-stop synchronization)
Communication Protocols	MEMOBUS (Master or Slave), MELSEC (A-compatible 1C frame, type:1), OMRON (only for host mode), Non-procedure
Media Access Control Method	1:1
Transmission Format (Can be set)	Data bit length: 7 or 8 bits Stop bits: 1 or 2 bits Parity bits: Even, odd, or none

Motion Control Modules

Applicable Models:    

● MECHATROLINK-II Motion Control Module (SVB-01)



Model: JAPMC-MC2310-E
Approx. Mass: 80 g

Items	Specifications
Communication Circuits	1 circuit
Communication Ports	2 ports
Terminator	External resistor (JEPMC-W6022 required)
Transmission Speed	10 Mbps
Communication Cycle	0.5 ms, 1 ms, 1.5 ms, 2 ms
Number of Connecting Stations*	21 stations (16 axes for servo drives) /2 ms, 15 stations (15 axes for servo drives) /1.5 ms, 9 stations (9 axes for servo drives) /1 ms, 4 stations (4 axes for servo drives) /0.5 ms
Retry Function	Available with MECHATROLINK-II
Slave Function	Available with MECHATROLINK-II
Transmission Distance	See "MECHATROLINK-II Repeater" on page 57.

*: MECHATROLINK-II (32-byte mode)

● MECHATROLINK-III Motion Control Module (SVC-01)



Model: JAPMC-MC2320-E
Approx. Mass: 70 g

Items	Specifications
Communication Circuits	1 circuit
Communication Ports	2 ports
Terminator	Not required
Transmission Speed	100 Mbps
Communication Cycle	125 μ s, 250 μ s, 500 μ s, 1 ms
Number of Connecting Stations	21 stations (16 axes for servo drives)/1 ms, 14 stations (14 axes for servo drives) /500 μ s, 8 stations (8 axes for servo drives) /250 μ s, 4 stations (4 axes for servo drives) /125 μ s
Retry Function	Available with MECHATROLINK-III
Slave Function	Not available
Transmission Distance	Distance between stations : 20 cm to 100 m

● Analog Output Motion Control Module (SVA-01)



Model: JAPMC-MC2300
Approx. Mass: 100 g

Items	Specifications
Number of Controlled Axes	2
Analog Output	2 channels/1 axis, -10 V to +10 V, 16-bit D/A
Analog Input	2 channels/1 axis, -10 V to +10 V, 16-bit A/D
Pulse Input	1 channel/1 axis, 5-V differential inputs, phase A/B pulse, and 4 Mpps (16 Mpps with 4 multipliers)
Input Signals	6 points/1 axis, 24 VDC, 4 mA, and source mode or sink mode input
Output Signals	6 points/1 axis, 24 VDC, 100 mA, open collector, and sink mode output

● Pulse Output Motion Control Module (PO-01)

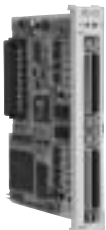

Model: JAPMC-PL2310-E
Approx. Mass: 100 g

Items	Specifications
Number of Controlled Axes	4
Pulse Output	Output Method : CW/CCW, sign + pulse, and phase A/B Maximum Frequency: 4 Mpps with CW/CCW or sign + pulse, 1 Mpps with phase A/B (before multiplication) Interface : 5-V differential outputs
Digital Input	5 points \times 4 channels, source mode input DI_0 : Separate for each power supply... 5 V/3.9 mA, 12 V/10.9 mA, 24 V/4.1 mA DI_1 to DI_4: Power supply shared ... 24 V/4.1 mA
Digital Output	4 points \times 4 channels Open collector (sink mode) output (24 V/100 mA)
Current Consumption	5 V, 1.0 A max.

I/O Modules Applicable Models:    

● I/O Modules (LIO-01/-02)



LIO-01 Module
Model: JAPMC-IO2300-E
Approx. Mass: 80 g



LIO-02 Module
Model: JAPMC-IO2301-E
Approx. Mass: 80 g

■ Digital I/O for LIO-01/-02 Modules

Items	Specifications
Input Signals	16 points (All connected) and 24 VDC \pm 20%, 5 mA (TYP) Sink mode or source mode input and photocoupler isolation Min. ON voltage/current: 15 V/1.6 mA Max. OFF voltage/current: 5 V/1.0 mA Max. Response time: OFF \rightarrow ON 1 ms and ON \rightarrow OFF 1 ms Interruption (DI-00): DI-00 can be used for interruptions. If an interruption is enabled, the interrupt drawing is started when DI-00 is set to ON. Pulse latch (DI-01): DI-01 can be used for pulse latching. If pulse latching is enabled, the pulse counter is latched when DI-01 is set to ON.
Output Signals	16 points (All connected) and 24 VDC \pm 20%, 100 mA max. Open collector: sink mode output (LIO-01 module) source mode output (LIO-02 module) Photocoupler isolation and Max. OFF current: 0.1 mA Max. Response time: OFF \rightarrow ON 1 ms and ON \rightarrow OFF 1 ms Output protection : Fuse (for protection against fires caused by an overcurrent when outputting after a short circuit occurred) If circuit protection is required, provide a fuse for each output circuit.

■ Pulse Input for LIO-01/-02 Modules

Items	Specifications
Number of Channels	1 (Phase A, B, or Z input)
Input Circuit	Phase A/B: 5 V differential inputs, no insulation, and max. frequency 4 MHz Phase Z: 5 V/12 V photocoupler inputs and max. frequency 500 kHz
Input Method	A/B (1, 2, or 4 multipliers), sign (1 or 2 multipliers), UP/DOWN (1 or 2 multipliers)
Latch Input	Pulse latch with phase Z or DI-01 Max. Response time: 5 μ s when input with phase Z; 60 μ s when input with DI-01
Others	Coincident detection; Preset and clear functions for counter values

● I/O Modules (LIO-04/-05)

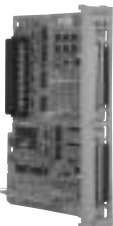

LIO-04 Module
Model: JAPMC-IO2303-E
Approx. Mass: 80 g

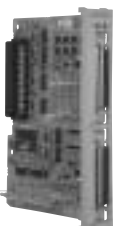

LIO-05 Module
Model: JAPMC-IO2304-E
Approx. Mass: 80 g

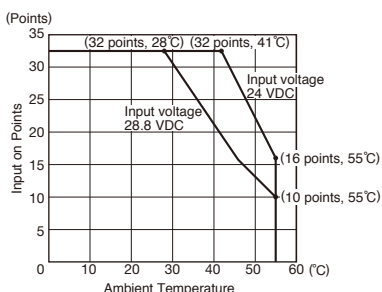
Items	Specifications
Input Signals	32 points (8 points connected) and 24 VDC \pm 20%, 5 mA (TYP) Sink mode or source mode input and photocoupler isolation Min. ON voltage/current: 15 V/1.6 mA Max. OFF voltage/current: 5 V/1.0 mA Max. Response time: OFF \rightarrow ON 0.5 ms and ON \rightarrow OFF 0.5 ms Interruption (DI-00, DI-01, DI-16, DI-17): DI-00, DI-01, DI-16, and DI-17 can be used for interruptions. If an interruption is enabled, the interrupt drawing is started when DI-00, DI-01, DI-16, or DI-17 is set to ON. <div style="display: flex; align-items: center;">  </div> Note: See right for the derating conditions.
Output Signals	32 points (8 points connected) and 24 VDC \pm 20%, 100 mA max. Open collector: sink mode output (LIO-04 module), source mode output (LIO-05 module) Photocoupler isolation and Max. OFF current: 0.1 mA Max. Response time: OFF \rightarrow ON 0.5 ms and ON \rightarrow OFF 1 ms Output protection: Fuse (for protection against fires caused by an overcurrent when outputting after a short circuit occurred) If circuit protection is required, provide a fuse for each output circuit.

Hardware Specifications

Hardware Specifications

● I/O Module (LIO-06)

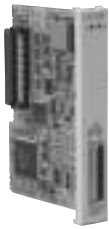

Model: JAPMC-IO2305-E
Approx. Mass: 80 g

■ LIO-06 Module Specifications

Items		Specifications
Digital Input Signals	Number of Input Points	8
	Input Method	Sink mode/source mode
	ON Voltage/Current	15 VDC min./2 mA min.
	OFF Voltage/Current	5 VDC max./1 mA max.
	Max. Response Time	OFF → ON: 0.5 ms max., ON → OFF: 0.5 ms max.
	Number of Common Points	1
Digital Output Signals	Number of Output Points	8
	Output Method	Sink mode
	External Voltage	19.2 VDC to 28.8 VDC
	Output Current	100 mA/point
	ON Voltage	1 V max.
	Current Leakage while OFF	0.1 mA max.
	Max. Response Time	OFF → ON: 0.25 ms max., ON → OFF: 1 ms max.
Number of Common Points	1	
Analog Input Signals	Analog Input Range	-10 V to +10 V
	Number of Channels	1
	Input Impedance	Approx. 20 kΩ
	Input Voltage Characteristics	±10 V (±31276) Resolution: 16 bits
Analog Output Signals	Analog Output Range	-10 V to +10 V
	Number of Channels	1
	Output Voltage Characteristics	±10 V (±31276) Resolution: 16 bits
Pulse Counter	Number of Channels	1
	Counter Mode	Reversible counter
	A/B Pulse Signal Form	5-V differential input
	A/B Pulse Signal Polarity	Positive logic/negative logic
	Pulse Counting Methods	Sign (Multiplier: 1 or 2) UP/DOWN (Multiplier: 1 or 2) A/B pulse (Multiplier: 1, 2, or 4)
	Max. Frequency	4 MHz
	Number of Latch Input Points	Can be selected from two points (Phase-Z latch or DI latch)
	Coincidence Detection Function	Available (Output terminal: DO_07)
Coincident Interruption	Available	

● Output Module (DO-01)



Model: JAPMC-DO2300-E
Approx. Mass: 80 g

Items	Specifications
Number of Output Points	64
Output Method	Transistor or open collector: sink mode output
Isolation	Photocoupler isolation
Output Voltage	24 VDC (19.2 V to 28.8 V)
Max. Output Current	100 mA
Max. OFF Current	0.1 mA
Max. Response Time	OFF → ON: 0.5 ms / ON → OFF: 1 ms
Number of Common Points	8
Protective Circuit	Fuse for common circuits
Fuse Rating	1 A
Error Detection	Fuse blowout detection

● Analog Input Module (AI-01)



Model: JAPMC-AN2300-E
Approx. Mass: 100 g

Items	Specifications
Analog Input Range	-10 V to +10 V 0 mA to 20 mA
Number of Channels	8 [(4 channels/connector) × 2]
Number of Channels to be Used	1 to 8
Isolation	Between channels: Not isolated, Between input connector and system power supply: Photocoupler isolation
Max. Rated Input	±15 V ±30 mA
Input Impedance	20 kΩ 250 Ω
Resolution	16 bits (-31276 to +31276) 15 bits (0 to +31276)
Accuracy (0°C to 55°C)	±0.3% (±30 mV)* ±0.3% (±0.06 mA)*
Input Conversion Time	1.4 ms max.
Current Consumption	5 V, 500 mA

*: After offset and gain adjustment by MPE720.

● Analog Output Module (AO-01)



Model: JAPMC-AN2310-E
Approx. Mass: 90 g

Items	Specifications
Number of Channels	4
Number of Channels to be Used	1 to 4
Isolation	Between channels: Not isolated, Between input connector and system power supply: Photocoupler isolation
Analog Output Range	-10 V to +10 V 0 V to +10 V
Resolution	16 bits (-31276 to +31276) 15 bits (0 to +31276)
Maximum Allowable Load Current	±5 mA
Accuracy	25°C ±0.1% (±10 mV)
	0°C to 55°C ±0.3% (±30 mV)
Output Delay Time	1.2 ms*
Current Consumption	5 V, 800 mA max.

*: After change with a full scale of -10 V to +10 V.

● Counter Module (CNTR-01)

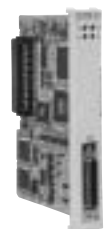

Model: JAPMC-PL2300-E
Approx. Mass: 85 g

Items	Specifications
Number of Channels	2
Input Circuit (Selected by software)	5-V differential: 4-MHz response frequency (RS-422, not isolated) 12 V: 120-kHz response frequency (12 V, 7 mA, current source mode input, and photocoupler isolation)
Input Method	A/B (1, 2, or 4 multipliers), UP/DOWN (1 or 2 multipliers), and sign (1 or 2 multipliers)
Counter Functions	Reversible counter, interval counter, and frequency measurement
Maximum Frequency	4 MHz with 5-V differential input (16 MHz with 4 multipliers)
Coincident Interruption	Simultaneous output to CPU module via system bus and output module.
Coincident Output	2 points, 24 V, 50 mA current sink mode input, and photocoupler isolation
DO Output	2 points, 24 V, 50 mA, current sink mode input, and photocoupler isolation (zone output, speed-coincidence output, and frequency-coincidence output)
PI Latch Input	2 points, 24 V, source mode input, and photocoupler isolation
Current Consumption	5 V, 600 mA

Hardware Specifications

I/O Modules for MECHATROLINK-II

Applicable Models:      

64-point I/O Modules (IO2310/IO2330)



Model: JEPMC-IO2310-E
Approx. Mass: 590 g



Model: JEPMC-IO2330-E
Approx. Mass: 590 g

Items	Specifications
I/O Signals	Input: 64 points, 24 VDC, 5 mA, sink/source mode input Output: 64 points, 24 VDC, 50 mA sink mode output (IO2310), source mode output (IO2330) Signal connection method: Connector (FCN360 series)
Module Power Supply	24 VDC (20.4 V to 28.8 V) Rated current: 0.5 A, Inrush current: 1 A

Various I/O Modules



Model: JEPMC-PL2900-E/PL2910-E,
JEPMC-AN2900-E/AN2910-E
Approx. Mass: 300 g



Model: JAMSC-IO2900-E/-IO2910-E,
JAMSC-IO2920-E/-IO2950-E
Approx. Mass: 300 g

Counter Module (PL2900)

Model	JEPMC-PL2900-E
Number of Input Channels	2
Functions	Pulse counter, notch output
Pulse Input Method	Sign (1/2 multipliers), A/B (1/2/4 multipliers), UP/DOWN (1/2 multipliers)
Max. Counter Speed	1200 kpps (4 multipliers)
Pulse Input Voltage	3/5/12/24 VDC
External Power Supply	For input signal: 24 VDC For driving load: 24 VDC For module: 24 VDC (20.4 V to 26.4 V) 150 mA or less

Pulse Output Module (PL2910)

Model	JEPMC-PL2910-E
Number of Output Channels	2
Functions	Pulse positioning, JOG run, zero-point return
Pulse Output Method	CW, CCW pulse, sign + pulse
Max. Output Speed	500 kpps
Pulse Output Voltage	5 VDC
Pulse Interface Circuit	Open collector output 5 VDC, 10 mA/circuit
External Control Signal	Digital input: 8 points/module 5 VDC × 4 points, 24 VDC × 4 points Digital output: 6 points/module 5 VDC × 4 points, 24 VDC × 2 points

Analog Input Module (AN2900)

Analog Output Module (AN2910)

Model	JEPMC-AN2900-E	JEPMC-AN2910-E
Number of Input/Output Channels	Input : 4	Output : 2
Input/Output Voltage Range	Input : -10 V to +10 V	Output : -10 V to +10 V
Input Impedance	1 MΩ min.	-
Max. Allowable Load Current	-	±5 mA (2 MΩ)
Data Region	-32000 to +32000	
Input/Output Delay Time	Input : 4 ms max.	Output : 1 ms max.
Error	+0.5% F.S (at 25°C), ±1.0% F.S (at 0°C to 60°C)	+0.2% F.S (at 25°C), ±0.5% F.S (at 0°C to 60°C)
External Power Supply	24 VDC (20.4 V to 26.4 V), 180 mA max.	

16-point Input Module (IO2900)

16-point Output Module (IO2910)

Model	JAMSC-IO2900-E	JAMSC-IO2910-E
Number of Input/Output Points	Input : 16	Output : 16
Rated Voltage	12/24 VDC	
Rated Current	2 mA/5 mA	0.3 A
Input/Output Method	Input : sink/source mode input	Output : sink mode output
External Power Supply	24 VDC (20.4 V to 28.8 V), 90 mA	24 VDC (20.4 V to 28.8 V), 110 mA

8-point I/O Module (IO2920)

Model	JAMSC-IO2920-E
Number of I/O Points	Input : 8, Output : 8
Rated Voltage	12/24 VDC
Rated Current	Input : 2 mA/5 mA Output : 0.3 A
Input/Output Method	Input : sink/source mode input Output : sink mode output
External Power Supply	24 VDC (20.4 V to 28.8 V), 90 mA

Relay Output Module (IO2950)

Model	JAMSC-IO2950-E
Number of Output Points	8
Rated Voltage	12/24 VDC, 100/200 VAC
Rated Current	1.0 A
Output Method	Contact output
External Power Supply	24 VDC (20.4 V to 28.8 V), 150 mA

● Image-processing Unit (MYVIS)

A networked machine vision system that processes images and takes into account the servo coordinate system with detection of the servo-axis position.



Model: JEVSA-YV260□□-E
Approx. Mass: 2.5 kg

Items		Standalone Type	
		Unit Type	
		For Analog Cameras	For Camera Link
Model		JEVSA-YV260□□-1-E	JEVSA-YV260□□-2-E
Image Processing		Gray scale pattern matching, binary image analysis etc.	
CPU		Main CPU : SH-4A (600 MHz), Sub CPU : SH-2A (200 MHz)	
Image Processing Hardware	LSI	FPGA	
	Pre-processing Function	Inter-image operations (addition, averaging, subtraction, and difference operation), 3×3 filter, dilation/erosion	
Memory	Application Program	512 Kbytes (flash memory)	
	Backup Memory	256 Kbytes CMOS (for saving parameters)	
	Template Storage Memory	CF cards (2 Gbytes max.)	
	Image Memory	Frame Memory	4096×4096×8 bits×4 images (Can be used for 640×480×8 bits×192 images)
	Template Memory	16 Mbytes	
Image Input	Camera Interface	New EIAJ 12-pin connector×4 EIA (640×480) to (1400×1050) Four B&W, 8-bit A/D-converter circuits	CameraLink (MDR26pin)×4 VGA (640×480) to QSXGA (2440×2048), Base Configuration, PoCL-compatible
	Camera Power Supply	Single camera : 12 V, 400 mA, Total : 1.2 A max.	
	Camera Sync Mode	Internal/external sync	Internal sync
	Random Shutter Supported	Sync-nonreset, sync-reset, single VD or V reset	
	Simultaneous Image Capture	Four cameras	
	Input Image Conversion	Gray level conversion (LUT), mirror mode	
Monitor	Monitor Output	VGA, XGA (color), 15pin D-sub	
	Image Display	A full-screen or a partial-screen for one camera, simultaneous screen reduction for two or four cameras, gray level conversion (binary image display supported)	
I/F	Field Network	MECHATROLINK-I / II	
	LAN (Ethernet)	10BASE-T/100BASE-TX	
	General-purpose Serial	RS-232C×2 channels (115.2 kbps)	
	Parallel I/O	16 general-purpose outputs (4 of these are also used for stroboscope) + 2 outputs exclusive for alarms (24 VDC, photocoupler isolation)	
		16 general-purpose inputs (4 of these are also used for trigger) + 3 inputs exclusive for mode switchings + 1 input exclusive for trigger (24 VDC, photocoupler isolation)	
	Track Ball	USB mouse	
Power Supply		100 V/200 VAC, 24 VDC, 30 W	

● MECHATROLINK-II Repeater

Required to stabilize communication and to extend the total length of the cable.



Model: JEPMC-REP2000-E
Approx. Mass: 340 g

Items	Specifications
Communication Type	MECHATROLINK-II
Max. Cable Length	Between controller and repeater: 50 m, After repeater: 50 m
Max. Connected Stations	Total stations on both sides of repeater: 30*
Restrictions	<p>The diagram illustrates the connection of a MECHATROLINK-II Repeater (REP 2000) between an M-II Master and a Terminator. Slave stations are connected to both sides of the repeater. The total cable length between the master and the repeater is limited to 100 m max. The cable length between the repeater and the terminator is also limited to 100 m max. For the segment between the master and the repeater, the total cable length is ≤ 30 m (15 stations max.) or 30 m < Total cable length ≤ 50 m (14 stations max.). For the segment between the repeater and the terminator, the total cable length is ≤ 30 m (16 stations max.) or 30 m < Total cable length ≤ 50 m (15 stations max.).</p>
Power Supply	24 VDC, 100 mA

*: Limited to the max. number of connectable stations of the controller (e.g., 21 stations for the MP2000 series).

MECHATROLINK-III Compatible Modules

Applicable Models:    

● Hub Module



Model : JEPMC-MT2000-E
Approx. Mass : 800 g

Items	Specifications
Data Transfer Method	MECHATROLINK-III
Transmission Speed	100 Mbps
Transmission Medium	MECHATROLINK-III cable, model : JEPMC-W6012-□□-E
Number of MECHATROLINK Ports	Master-side port : 1 (CNM1) to connect the master station Slave-side port : 8 (CNS1 to CNS8) to connect slave stations
Arbitration	FIFO arbitration discipline Error when multiple slave-side ports receive data at the same time
Transmission Delay Time between Ports	600 ns (typ)
Indicators	1 indicator for power supply ON/OFF, 9 indicators for port link status
External Power Supply	24 VDC (±20%), 0.5 A (CN1)
Installation Orientation	Vertical or horizontal
Exterior	Painted

● Network Analyzer Module



Model : JEPMC-MT2010-E
Approx. Mass : 270 g

Traces the data sent or received through MECHATROLINK-III communication (cyclic communication).

Items	Specifications
Power Supply	Input supply voltage : 24 VDC ±20% Current consumption : 1 A max. Inrush current : 40 A
Motion Network	Two circuits for MECHATROLINK-III (To be connected to the end of network connection.) Transmission speed : 100 Mbps (MECHATROLINK-III) Transmission distance : 20 cm to 100 m Terminator : not required
Communication Ports	1 port (Ethernet : 100BASE-TX/10BASE-T)

Note : Requires the network analyzer tool (model : CMPC-NWAN710) for settings and operation.

● Network Adapter Module



Model : JEPMC-MT2020-E
Approx. Mass : 270 g

Relays MECHATROLINK-III messages from Ethernet port to MECHATROLINK-III network.

Items	Specifications
Power Supply	Input supply voltage : 24 VDC ±20% Current consumption : 1 A max. Inrush current : 40 A
Motion Network	Two circuits for MECHATROLINK-III (To be connected to the end of network connection.) Transmission speed : 100 Mbps (MECHATROLINK-III) Transmission distance : 20 cm to 100 m Terminator : not required
Communication Ports	1 port (Ethernet : 100BASE-TX/10BASE-T)

Note : Requires the adapter tool (model : CMPC-NWAD710) for settings and operation.

The adapter tool is available for free. Download it from Yaskawa's Product and Technical Information on Yaskawa's website at <http://www.e-mechatronics.com>.

● 64-point I/O Module



Model : JEPMC-MTD2310-E
Approx. Mass : 550 g

Items	Specifications
I/O Signals	Input: 64 points, 24 VDC, 5 mA, sink/source mode input Output: 64 points, 24 VDC, 50 mA when all points ON* sink mode output
Module Power Supply	24 VDC (20.4 V to 28.8 V) Rated current: 0.5 A

* : The max. rating is 100 mA per point (depending on derating conditions).

● Analog Input Module (MTA2900)



Model : JEPMC-MTA2900-E
Approx. Mass : 300 g

Items		Specifications	
Analog Input	Analog Input Range	-10 V to +10 V	0 mA to 20 mA
	Number of Channels	8 [(4 channels/connector)×2]	
	Number of Channels to be Used	1 to 8	
	Isolation	Between channels: Not isolated	
	Max. Rated Input	±15 V	±30 mA
	Input Impedance	20 kΩ	250 Ω
	Resolution	16 bits (-31276 to +31276)	15 bits (0 to +31276)
	Accuracy (0°C to 55°C)	±0.3% (±30 mV)	±0.3% (±0.06 mA)
	Input Conversion Time	1.4 ms max.	
Motion Network	Two circuits for MECHATROLINK-III Transmission distance : 20 cm to 100 m	Transmission speed : 100 Mbps Terminator : not required	
Module Power Supply	24 VDC (20.4 V to 28.8 V), 500 mA max.		

● Analog Output Module (MTA2910)



Model : JEPMC-MTA2910-E
Approx. Mass : 300 g

Items		Specifications		
Analog Output	Analog Output Range	-10 V to +10 V	0 V to +10 V	
	Number of Channels	4		
	Number of Channels to be Used	1 to 4		
	Isolation	Between channels: Not isolated		
	Resolution	16 bits (-31276 to +31276)	15 bits (0 to +31276)	
	Maximum Allowable Load Current	±5 mA		
	Accuracy	25°C	±0.1% (±10 mV)	
		0°C to 55°C	±0.3% (±30 mV)	
Output Delay Time	1.2 ms*			
Motion Network	Two circuits for MECHATROLINK-III Transmission distance : 20 cm to 100 m	Transmission speed : 100 Mbps Terminator : not required		
Module Power Supply	24 VDC (20.4 V to 28.8 V), 500 mA max.			

*: After change with a full scale of -10 V to +10 V.

● Pulse Input Module (MTP2900)



Model : JEPMC-MTP2900-E
Approx. Mass : 300 g

Items		Specifications	
Pulse Input	Number of Channels	2	
	Input Circuit (Selected by software)	5-V differential: 4-MHz response frequency (RS-422, not isolated) 12 V: 120-kHz response frequency (12 V, 7 mA, current source mode input, and photocoupler isolation)	
	Input Method	A/B (1, 2, or 4 multipliers), UP/DOWN (1 or 2 multipliers), and sign (1 or 2 multipliers)	
	Counter Functions	Reversible counter, interval counter, and frequency measurement	
	Maximum Frequency	4 MHz with 5-V differential input (16 MHz with 4 multipliers)	
	Coincident Output	2 points, 24 V, 50 mA current sink mode input, and photocoupler isolation	
	DO Output	2 points, 24 V, 50 mA, current sink mode input, and photocoupler isolation (zone output, speed-coincidence output, and frequency-coincidence output)	
	PI Latch Input	2 points, 24 V, source mode input, and photocoupler isolation	
Input Method	Sign, UP/DOWN and A/B pulse		
Motion Network	Two circuits for MECHATROLINK-III Transmission distance : 20 cm to 100 m	Transmission speed : 100 Mbps Terminator : not required	
Module Power Supply	24 VDC (20.4 V to 28.8 V), 500 mA		

● Pulse Output Module (MTP2910)



Model : JEPMC-MTP2910-E
Approx. Mass : 300 g

Items		Specifications	
Pulse Output	Number of Controlled Axes	4	
	Pulse Output	Output Method : CW/CCW, sign + pulse, and phase A/B Maximum Frequency : 4 Mpps with CW/CCW or sign + pulse, 1 Mpps with phase A/B (before multiplication) Interface : 5-V differential outputs	
	Digital Input	5 points × 4 channels, source mode input DI_0 : Separate for each power supply... 5 V/3.9 mA, 12 V/10.9 mA, 24 V/4.1 mA DI_1 to DI_4: Power supply shared ... 24 V/4.1 mA	
	Digital Output	4 points × 4 channels Open collector and sink mode output (24 V/100 mA)	
Motion Network	Two circuits for MECHATROLINK-III Transmission distance : 20 cm to 100 m	Transmission speed : 100 Mbps Terminator : not required	
Module Power Supply	24 VDC (20.4 V to 28.8 V), 500 mA		

Hardware Specifications

Other Modules

Contact individual manufacturers for more details.

AnyWire DB Master

Applicable Models:    

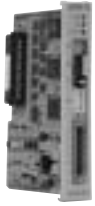

Model: AFMP-01
Approx. Mass: 90 g

Made by
Anywire Corporation

Items	Specifications			
Transmission Clock	7.8 kHz	15.6 kHz	31.3 kHz	62.5 kHz
Max. Transmission Distance	1 km	500 m	200 m	100 m
Transmission Protocol	Special protocol (Anywire Bus DB protocol) Note: Upper compatibility with UNI-WIRE protocol			
Max. Number of I/Os	Full triple mode: 2304 points (Bit-Bus: 256 points, Word-Bus: 2048 points) Full quadruple mode: 2560 points (Bit-Bus: 512 points, Word-Bus: 2048 points)			
Dual-Bus Function	Bit-Bus	Full triple mode: 256 bits max., Full quadruple mode: 512 bits max.		
	Word-Bus	Full triple mode: 128 words max. (64 words each for IN and OUT), Full quadruple mode: 128 words max. (64 words each for IN and OUT)		
Max. Number of Stations	128 stations (Fan-out = 200) Note: Anywire DB products: Fan-in = 1, UNI-WIRE products: Fan-in = 10			
Connection Cable	General-purpose 2-wire cable or 4-wire cable (VCTF 0.75 sq to 1.25 sq) Special flat cable (0.75 sq), general purpose wire (0.75 sq to 1.25 sq)			

CC-Link Interface Board

Applicable Models:    



Model: AFMP-02-C
Approx. Mass: 90 g

Made by
Anywire Corporation



Model: AFMP-02-CA
Approx. Mass: 90 g

Made by
Anywire Corporation

Items	Specifications	AFMP-02-C	AFMP-02-CA
CC-Link Specifications	Station Type	Remote device station	
	Number of Stations	4	
	No. of Remote Stations	Station number setting range: 1 to 61 (4 stations are occupied after setting the number of stations)	
	No. of Remote Device Points	Input: Max. 896 points, Output: Max. 896 points (Version 2.0 with 8 times setting) Input: Max. 112 points, Output: Max. 112 points (Version 1.1)	
	No. of Remote Register Points	Input: Max. 128 points, Output: Max. 128 points (Version 2.0 with 8 times setting) Input: Max. 16 points, Output: Max. 16 points (Version 1.1)	
	Transmission Speed	10 M, 5 M, 2.5 M, 625 k, and 156 kbps (Select with the switch.)	
	Transmission Distance	100 m (10 Mbps), 160 m (5 Mbps), 400 m (2.5 Mbps), 900 m (625 kbps), and 1200 m (156 kbps)	
No. of CC-Link that can be connected	$(1 \times a) + (2 \times b) + (3 \times c) + (4 \times d) \leq 64$ [a: Number of slave products that occupy one station, b: Number of slave products that occupy two stations, c: Number of slave products that occupy three stations, d: Number of slave products that occupy four stations] $(16 \times A) + (54 \times B) + (88 \times C) \leq 2304$ [A: Number of remote I/O stations (Max. 64 units) B: Number of remote device station units (Max. 42 units) C: Number of local station and intelligent device station units (Max. 26 units)]	●	●
Connection Cable	CC-Link cable; a three-core, shielded, twisted-pair cable	●	●
Anywire DB Specifications	Transmission Clock	7.8 kHz, 15.6 kHz, 31.3 kHz, and 62.5 kHz	
	Max. Transmission Distance	Max. Overall Cable Extension Length: 100 m, 200 m, 500 m, or 1 km.	
	I/O Points	Full triplex mode: Max. 2304 points (Bit-bus: Max. 256 points, Word-bus: Max. 2048 points) Full quadruplex mode: 2560 points (Bit-bus: Max. 512 points, Word-bus: Max. 2048 points)	
	Anywire Bus Port	One port, detachable terminal block	
Connection Cable	General-purpose 2-core or 4-core cable (VCTF 0.75 sq to 1.25 sq), dedicated flat cable (0.75 sq), general-purpose wire (0.75 sq to 1.25 sq)	—	●

● A-net/A-Link Master Unit Module

 Applicable Models:    

Items	A-net	A-Link
Communication Control IC	MKY40	MKY36
Communication Mode	Two-wire, half-duplex	Four-wire full duplex / two-wire half duplex
Transmission Speed	3/6/12 Mbps	3/6/12 Mbps
Error Detection	CRC-16	CRC-12
Transmission Distance	300/200/100 m	300/200/100 m

Model: MPANL00-0
Approx. Mass: 90 g

Made by
Algo System Co., Ltd.

● CUnet Master Module

 Applicable Models:    

Item	Specifications
Communication Control IC	MKY40×1
Communication Mode	Two-wire, half-duplex (comforms to RS-485 specifications)
Isolation Method	Pulse transformer
Transmission Speed	3 Mbps, 6 Mbps, or 12 Mbps (recommended)
Synchronization Method	Bit synchronization
Error Detection	CRC-16
Max. Transmission Distance	12 Mbps: 100 m; 6 Mbps: 200 m; 3 Mbps: 300 m
Connection Method	Multidrop connection
Impedance	100Ω
Terminator	Enabled or disabled with the built-in switch.
External Interface	Euro-style, 6-pin terminal block

Model: MPCUNET-0
Approx. Mass: 85 g

Made by
Algo System Co., Ltd.

Hardware Specifications

Dimensions Units: mm

● MP2100, MP2101, MP2101T Board (Half the Size of Standard PCI)

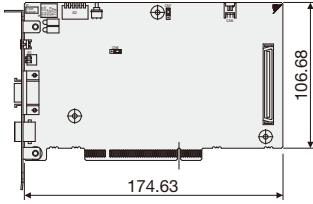

● MP2100M, MP2101M, MP2101TM Board (Half the Size of Standard PCI)

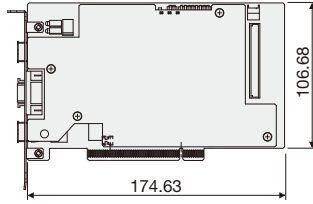

● MP2100MEX Board

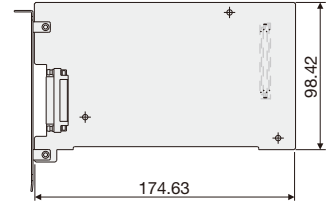

● MP2200 Base Unit

BU2200 (MBU-01), BU2210 (MBU-02)

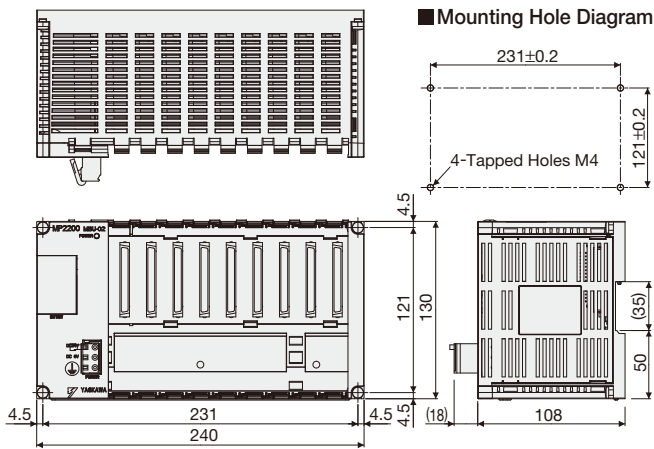

BU2220 (MBU-03)

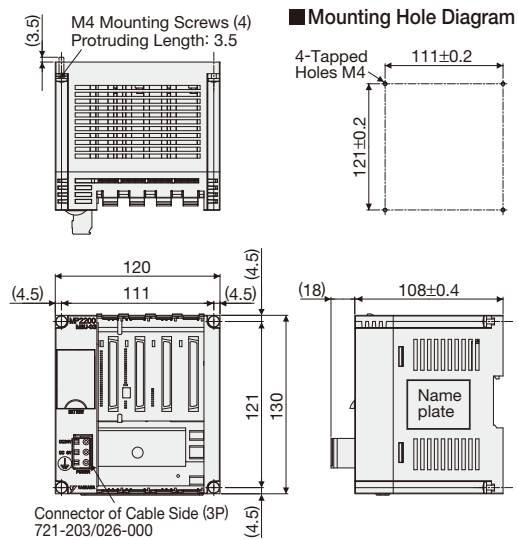

● MP2300, MP2310 Basic Module

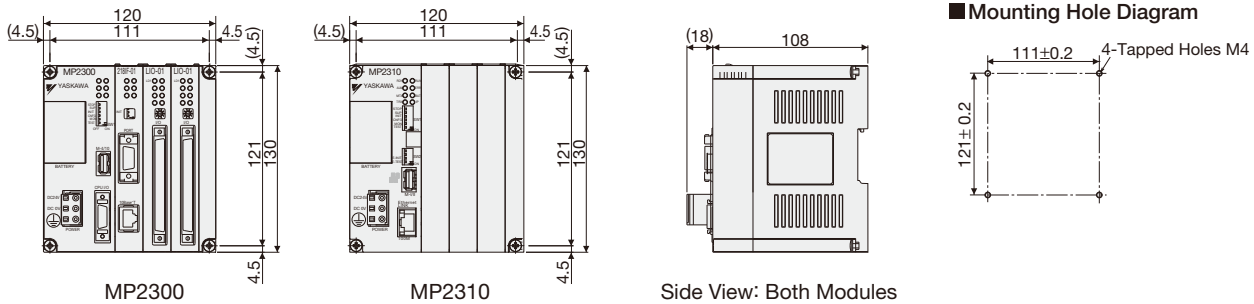

● MP2300S Basic Module

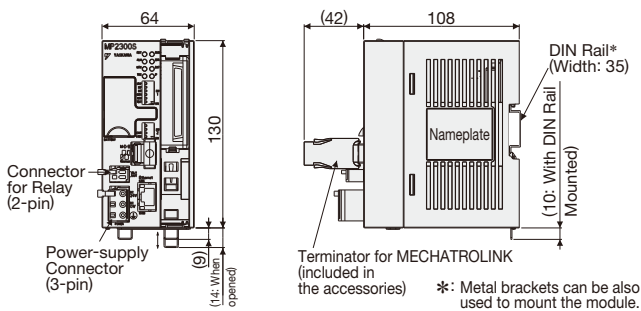

● MP2400

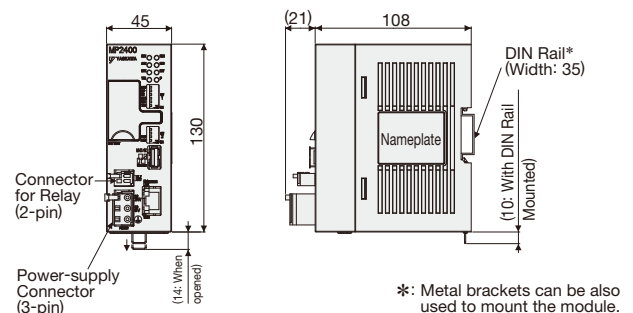

● Touch Panel with Integrated 15-inch Display (MP2500/MP2500M)

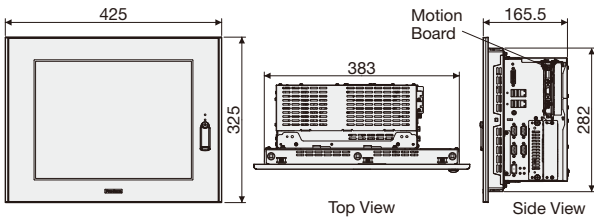

● Touch Panel with Integrated 12.1-inch Display (MP2500/MP2500M)

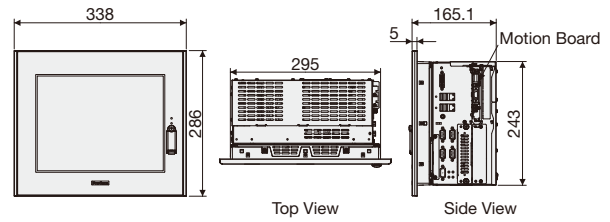

● Touch Panel with Separate 10.4-inch Display (PNL-10)

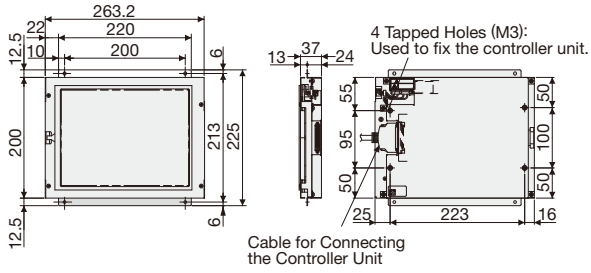

● Touch Panel with Separate 12.1-inch Display (PNL-12)

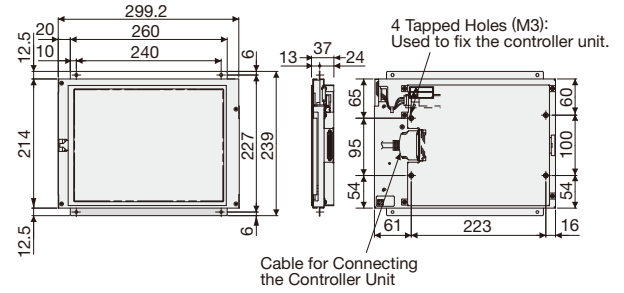

● Separated PC Box (MP2500B/MP2500MB)

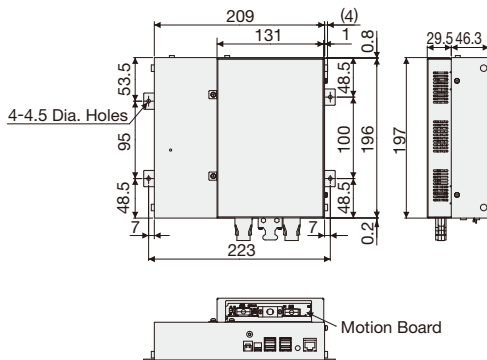

● Separated PC Box (MP2500B-OP/MP2500MB-OP)

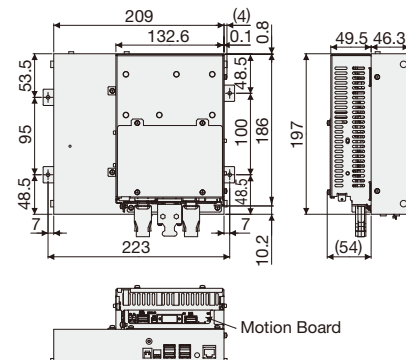

Hardware Specifications

MECHATROLINK-II Compatible Modules

64-point I/O Module

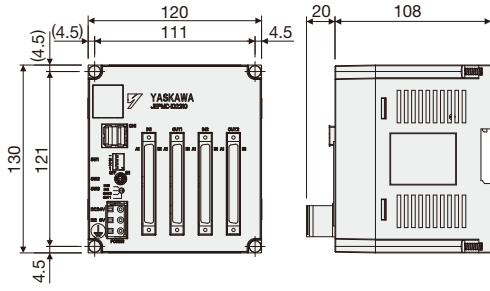

Mounting Hole Diagram

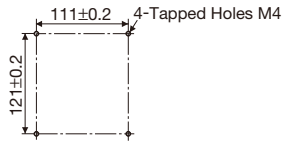

Counter, Pulse, and Analog Modules

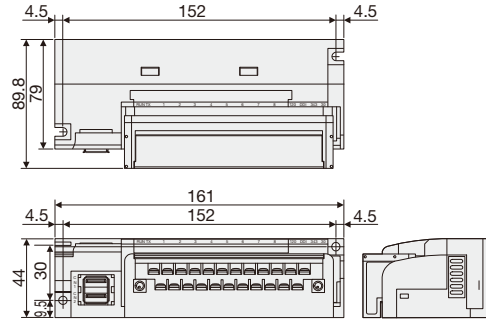

Mounting Hole Diagram (Two Methods)

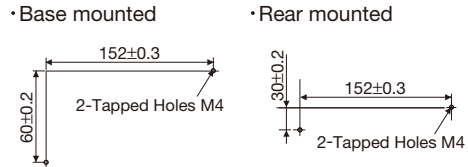

16-point/8-point I/O Module, Relay Output Module

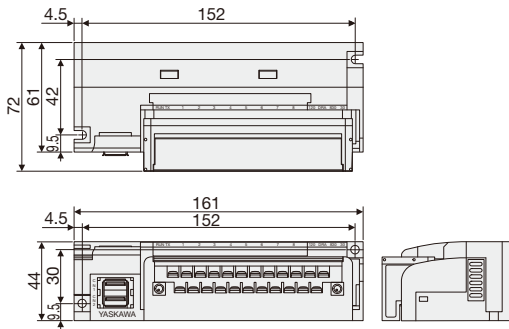

MECHATROLINK-III Compatible Modules

Hub Module

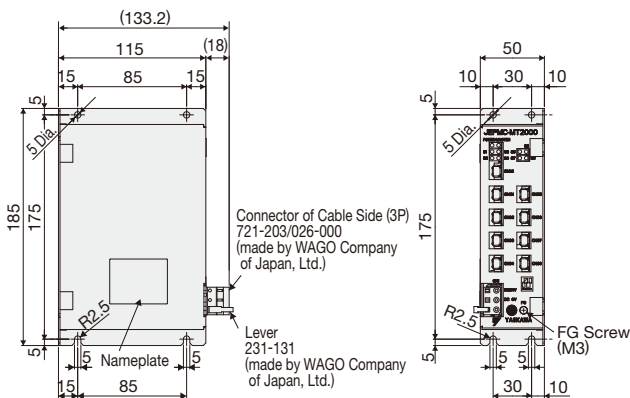

Network Analyzer, Network Adapter Module

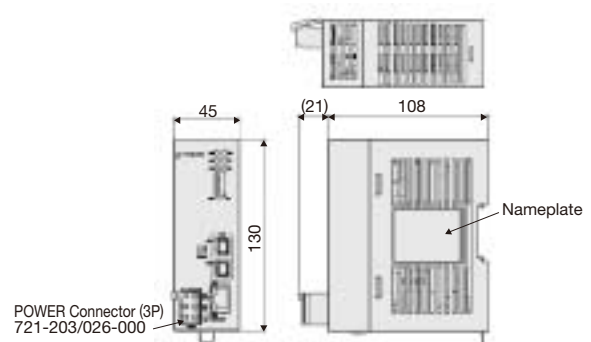

● MECHATROLINK-III Compatible Modules (Cont'd)

64-point I/O Module

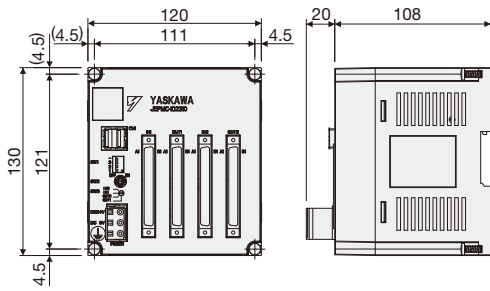

■ Mounting Hole Diagram

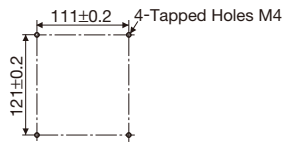

Analog Input Module

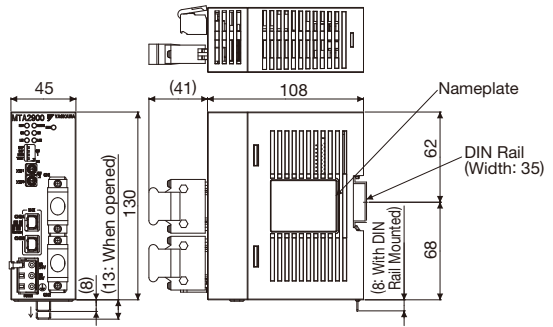

Analog Output Module

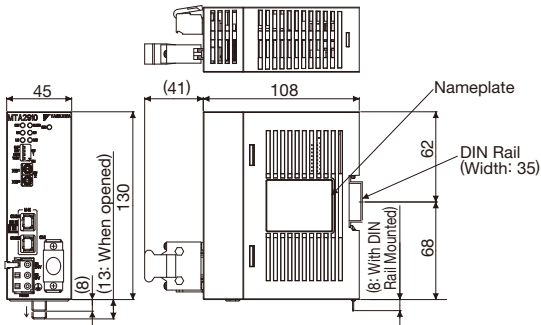

Pulse Input Module

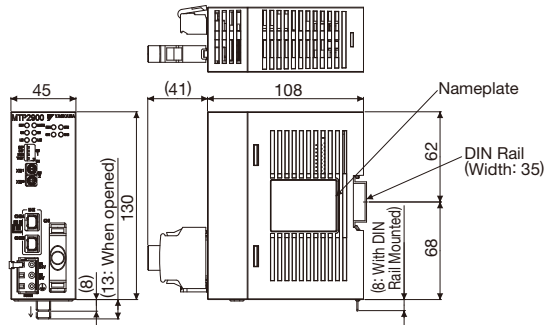

Pulse Output Module

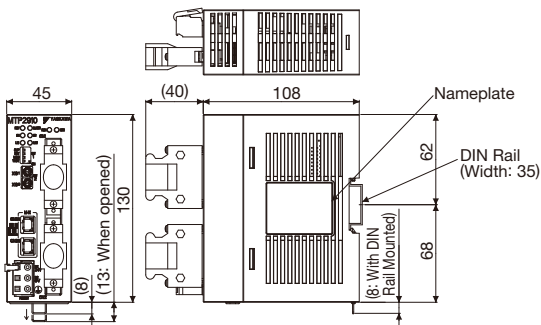

Motion Controls

Items	Specifications																				
Control Specifications	PTP control, interpolation, speed reference output, torque reference output, position reference output, phase reference output																				
Zero-point Return (17 types)	<table style="width: 100%; border-collapse: collapse;"> <tr> <td style="width: 25%;">① DEC1+C</td><td style="width: 25%;">② ZERO</td><td style="width: 25%;">③ DEC1+ZERO</td><td style="width: 25%;">④ C pulse</td></tr> <tr> <td>⑤ DEC2+ZERO</td><td>⑥ DEC1+LMT+ZERO</td><td>⑦ DEC2+C</td><td>⑧ DEC1+LMT+C</td></tr> <tr> <td>⑨ C pulse only</td><td>⑩ POT & C pulse</td><td>⑪ POT only</td><td>⑫ HOME LS & C</td></tr> <tr> <td>⑬ INPUT</td><td>⑭ HOME only</td><td>⑮ NOT & C pulse</td><td>⑯ NOT only</td></tr> <tr> <td>⑰ INPUT & C pulse</td><td colspan="3" style="text-align: right;">Note: Types ⑤ to ⑯ are available only with SVA.</td></tr> </table>	① DEC1+C	② ZERO	③ DEC1+ZERO	④ C pulse	⑤ DEC2+ZERO	⑥ DEC1+LMT+ZERO	⑦ DEC2+C	⑧ DEC1+LMT+C	⑨ C pulse only	⑩ POT & C pulse	⑪ POT only	⑫ HOME LS & C	⑬ INPUT	⑭ HOME only	⑮ NOT & C pulse	⑯ NOT only	⑰ INPUT & C pulse	Note: Types ⑤ to ⑯ are available only with SVA.		
① DEC1+C	② ZERO	③ DEC1+ZERO	④ C pulse																		
⑤ DEC2+ZERO	⑥ DEC1+LMT+ZERO	⑦ DEC2+C	⑧ DEC1+LMT+C																		
⑨ C pulse only	⑩ POT & C pulse	⑪ POT only	⑫ HOME LS & C																		
⑬ INPUT	⑭ HOME only	⑮ NOT & C pulse	⑯ NOT only																		
⑰ INPUT & C pulse	Note: Types ⑤ to ⑯ are available only with SVA.																				
Number of Controlled Axes	1 to 16 axes (1 group)																				
Reference Unit	mm, inch, deg, pulse																				
Reference Unit Minimum Setting	1, 0.1, 0.01, 0.001, 0.0001, 0.00001																				
Coordinate System	Rectangular coordinates																				
Max. Programmable Value	-2147483648 to +2147483647 (signed 32-bit value)																				
Speed Reference Unit	mm/min, inch/min, deg/min, pulse/min, mm/s, inch/s, deg/s, pulse/s																				
Acceleration/Deceleration Type	Linear, asymmetric, S-curve																				
Override Function	Positioning: 0.01% to 327.67% by axis Interpolation: 0.01% to 327.67% by group																				
Programs	Language	Motion language, ladder language																			
	Number of Tasks	16 (Equal to the number of tasks that the ladder instruction, MSEE, can execute at the same time.)																			
	Number of Programs	Up to 256																			
	Program Capacity	MP2200	36 k lines (1.6 M characters) when the ladder program has 4 k steps. [Varies according to the size of the motion program used. For example, the motion program has 24 k lines (1.2 M characters) when the ladder program has 40 k steps.]																		
	MP2500, MP2500M, MP2300, MP2310, MP2300S, MP2100, MP2100M	24 k lines (1.2 M characters) when the ladder program has 4 k steps. [Varies according to the size of the motion program used. For example, the motion program has 16 k lines (800 k characters) when the ladder program has 40 k steps.]																			
	MP2400	Equivalent to 800 k characters only when using motion programs.																			

Support Tools (Optional)

● MPE720 Version 7 Engineering Tool Model: CPMC-MPE780

■ Hardware and Software Requirements

Item	Specifications
CPU	Pentium 800 MHz or more (1 GHz or more recommended)
Memory	512 Mbytes or more (1 Gbytes or more recommended)
Free Hard Disk Space	700 Mbytes min.
Display	Resolution: 1024×768 pixels min.
CD Drive	1 (only for installation)
Communication Port	RS-232C, Ethernet, MP2100 bus, or USB
OS	Windows7 (32bit, 64bit) (recommended)
	WindowsVista (HomeBasic, HomePremium, Business, Ultimate, Enterprise)
	WindowsXP (Professional, HomeEdition)
.Net Environment	.Net Framework2.0 SP1 or later
Languages Supported	English, Japanese

Note: Pentium is a registered trademark of the Intel Corporation.
 Ethernet is a registered trademark of the Xerox Corporation.
 Windows 7, Windows XP, Windows Vista are registered trademarks of the Microsoft Corporation.

■ Functions

Item	Specifications
Programming	Ladder programs (ladder language)
	Motion programs (motion language)
Variables, Comments	Variable database management
	System and user variables, axis variables, input/output variables, global variables, system and user structures
Search, Replace	Cross-reference searches, instruction searches, character string and comment searches
	Register replacement, character string and comment replacement
Monitor	Register lists
	Watch
	Adjustment panel
	Axis operation monitor
	Axis alarm monitor
Tracing	Operation control panel
	Real-time tracing
	X-Y tracing
MC-Configurator	Trace manager
	Module configuration definitions (unit, module, slave allocation)
	Module detail definitions (system settings, communication settings, etc.)
	Parameter editing (fixed, setting, monitor, servo, distributed I/O, etc.)
	Servo adjustments (setup, test operation, tuning)
Security Functions	Inverter adjustments (setup)
	Project file security
	Program security (ladder programs, motion programs)
	On-line security (access limited to users with specific levels of authority)
Servicing and Maintenance	User management
	Status list
System	Language switching (between Japanese and English)
Remote Engineering	Modem connection
	RAS server connection
Electronic Cam Tool	Electronic cam data generation
Help	On-line manual help (help for instructions, operations)
	Version information
Printing	Preview
	Program
	Cross reference
Customized Functions	Editor
	Toolbar

■ Instructions for Motion Programs

Type	Instruction	Function
Axis Setting Instructions	ABS	Absolute Mode
	INC	Incremental Mode
	ACC	Change Acceleration Time
	DCC	Change Deceleration Time
	SCC	Change S-curve Time Constant
	VEL	Set Speed
	FMX	Set Maximum Interpolation Feed Speed
	IFP	Set Interpolation Feed Speed Ratio
	IAC	Change Interpolation Acceleration Time
	IDC	Change Interpolation Deceleration Time
Axis Movement Instructions	MOV	Positioning
	MVS	Linear Interpolation
	MCW	Clockwise: Circular Interpolation, Herical Interpolation
	MCC	Counterclockwise: Circular Interpolation, Herical Interpolation
	ZRN	Zero Point Return
	SKP	Skip Function
	MVT	Set-time Positioning
	EXM	External Positioning
Axis Control Instructions	POS	Set Current Position
	MVM	Move on Machine Coordinates
	PLD	Update Program Current Position
	PFN	In-Position Check
	INP	In-Position Range
	PLN	Coordinate Plane Setting
Program Control Instructions	IF	Branching
	ELSE	
	IEND	
	WHILE	Repetition
	WEND	
	PFORK	Parallel Execution
	JOINTO	
	PJOINT	
	SFORK	Selective Execution
	JOINTO	
	SJOINT	
	MSEE	Call Subprogram
	FUNC	User Function
	END	Program End
	RET	Subprogram Return
	TIM	Dwell Time
	IOW	I/O Variable Wait
	EOX	One Scan Wait
SNGD/	Disable Single-block Signal (SNGD) and Enable Single-block Signal (SNGE)	
SNGE		
Other Control Instructions	=	Substitution
	+, -, *, /, MOD	Numeric operations
	, ^, &, !	Logic operations
	SIN, COS, TAN, ASN, ACS, ATAN, SQRT, BIN, BCD	Basic functions
	==, <>, >, <	Numeric comparison
	>=, <=	
	SFR, SFL, BLK, CLR, ASCII	Data manipulation
	(), S{ }, R{ }	Others

■ Instructions for Sequence Programs

Type	Instruction	Function
Control Instructions	SSEE	Sequence program call
	UFC	User function call
Sequence Control Instructions	PON	Rising pulse
	NON	Falling pulse
	TON	Turn On Delay timer (10ms)
	TOF	Turn OFF Delay timer (10ms)

Software Specifications

● MPE720 Version 7 Engineering Tool (Cont'd)

■ Instructions for Ladder Programs

Type	Instruction	Function
Relay Circuit Instructions	NOC	NO Contact
	NCC	NC Contact
	TON [10 ms]	10-ms ON-Delay Timer
	TOFF [10 ms]	10-ms OFF-Delay Timer
	TON [1 s]	1-s ON-Delay Timer
	TOFF [1 s]	1-s OFF-Delay Timer
	ON-PLS	Rising-edge Pulses
	OFF-PLS	Falling-edge Pulses
	COIL	Coil
	S-COIL	Set Coil
R-COIL	Reset Coil	
Numeric Operation Instructions	STORE	Store
	ADD (+)	Add
	ADDX (++)	Extended Add
	SUB (-)	Subtract
	SUBX (-)	Extended Subtract
	MUL (x)	Multiply
	DIV (÷)	Divide
	MOD	Integer Remainder
	REM	Real Remainder
	INC	Increment
	DEC	Decrement
	TMADD	Add Time
	TMSUB	Subtract Time
	SPEND	Spend Time
	INV	Invert Sign
	COM	One's Complement
	ABS	Absolute Value
	BIN	Binary Conversion
	BCD	BCD Conversion
	PARITY	Parity Conversion
ASCII	ASCII Conversion 1	
BINASC	ASCII Conversion 2	
ASCBIN	ASCII Conversion 3	
Logic Operation Instructions	AND	AND
	OR	Inclusive OR
	XOR	Exclusive OR
	<	Less Than
	≤	Less Than or Equal
	=	Equal
	≠	Not Equal
	≥	Greater Than or Equal
	>	Greater Than
RCHK	Range Check	
Program Control Instructions	SEE	Call Sequence Subprogram
	MSEE	Call Motion Program
	FUNC	Call User Function
	INS	Direct Input String
	OUTS	Direct Output String
	XCALL	Call Extended Program
	WHILE END_WHILE	WHILE construct
	FOR END_FOR	FOR construct
	IF END_IF	IF construct
	IF ELSE END_IF	IF-ELSE construct
	EXPRESSION	Numerical expressions

Type	Instruction	Function
Basic Function Instructions	SQRT	Square Root
	SIN	Sine
	COS	Cosine
	TAN	Tangent
	ASIN	Arc Sine
	ACOS	Arc Cosine
	ATAN	Arc Tangent
	EXP	Exponential
	LN	Natural Logarithm
	LOG	Common Logarithm
Data Manipulation Instructions	ROTL	Bit Rotate Left
	ROTR	Bit Rotate Right
	MOVB	Move Bit
	MOVW	Move Word
	XCHG	Exchange
	SETW	Table Initialization
	BEXTD	Byte-to-word Expansion
	BPRESS	Word-to-byte Compression
	BSRCH	Binary Search
	SORT	Sort
	SHFTL	Bit Shift Left
	SHFTR	Bit Shift Right
	COPYW	Copy Word
	BSWAP	Byte Swap
DDC Instructions	DZA	Dead Zone A
	DZB	Dead Zone B
	LIMIT	Upper/Lower Limit
	PI	PI Control
	PD	PD Control
	PID	PID Control
	LAG	First-order Lag
	LLAG	Phase Lead Lag
	FGN	Function Generator
	IFGN	Inverse Function Generator
	LAU	Linear Accelerator/Decelerator 1
SLAU	Linear Accelerator/Decelerator 2	
PWM	Pulse Width Modulation	
Table Manipulation Instructions	TBLBR	Read Table Block
	TBLBW	Write Table Block
	TBLSRL	Search Table Row
	TBLSRC	Search Table Column
	TBLCL	Clear Table Block
	TBLMV	Move Table Block
	QTBLR	Read Queue Table
	QTBLRI	Read Queue Table with Pointer Increment
	QTBLW	Write Queue Table
QTBLWI	Write Queue Table with Pointer Increment	
QTBLCL	Clear Queue Table Pointer	
Standard System Function Instructions	COUNTER	Counter
	FINFOUT	First-in First-out
	TRACE	Trace
	DTRC-RD	Read Data Trace
	ITRC-RD	Inverter trace read
	MSG-SND	Send Message
	MSG-RCV	Receive Message
	ICNS-WR	Inverter constant write
	ICNS-RD	Inverter constant read
	MLNK-SVW	SERVOPACK constant write
	MOTREG-W	Motion register write
MOTREG-R	Motion register read	

■ EXPRESSION instructions

Type	Symbol	Function
Arithmetic Operators	=	Store instruction
	+	Addition
	-	Subtraction
	*	Multiplication
	/	Division
	&	AND instruction (bit operation)
		OR instruction (bit operation)
Logical Operators	^	Exclusive OR instruction (bit operation)
	&&	AND instruction
		OR instruction
Comparison Operators	!	Logical NOT instruction
	<	Less than
	<=	Less than or equal
	==	Equal
	!=	Not equal
Program Control Instructions	>=	Greater than or equal
	>	Greater than
	FOR <variable> = <initial value> TO <final value> STEP <step value> * * * FEND	Fixed count repetition control
	WHILE <conditional expression> * * * WEND	Pre-tested repetition control
	IF <B register operation conditional expression>	Conditional branching
	ELSE	Conditional branching (2)

Type	Symbol	Function	
Basic Function Instructions	SQRT	SQRT_W	Square root instructions
		SQRT_F	
		SQRT_D	
	SIN	SIN_W	Sine instructions (real number operations)
		SIN_F	
		SIN_D	
	COS	COS_W	Cosine instructions (real number operations)
		COS_F	
		COS_D	
	TAN		Tangent instruction
	ASIN		Arc sine instruction
	ACOS		Arc cosine instruction
	ATAN	ATAN_W	Arc tangent instructions (real number operation)
ATAN_F			
ATAN_D			
EXP		Exponential instruction	
LN		Natural logarithm instruction	
LOG		Common logarithm instruction	
Cast Operators	(WORD)	word	
	(LONG)	long	
	(FLOAT)	float	
	FTYPE	Float-type operation specification	

□ : New instructions

■ Electronic Cam Data Generation Tool

Items	Specifications
Data Generation	Cam curves can be selected from: <ul style="list-style-type: none"> • Straight line • Cycloid • Modified constant velocity • Trapecloid • Single-dwell modified trapezoid m=1 • Single-dwell modified sine • No-dwell modified trapezoid • Free-form curve • Inverted paired strings • Parabolic • Modified trapezoid • Asymmetrical cycloid • Single-dwell cycloid m=1 • Single-dwell ferguson trapezoid • Single-dwell trapecloid • No-dwell modified constant velocity • Inverted trapecloid • Simple harmonic • Modified sine • Asymmetrical modified trapezoid • Single-dwell cycloid m=2/3 • Single-dwell modified trapezoid m=2/3 • No-dwell simple harmonic • NC2 curve • Paired strings
Data Editing	Data graph: Parameter setting, style setting, graph data editing Data list: Insert, delete, etc. Control graph display: Displacement data, speed data, acceleration data, jerk data, graph comparison
Data Transfer	Cam data file is transferred to registers (M or C)

Software Specifications

● Motion API Model: CPMC-MPA700

■ Hardware and Software Requirements

Items	Specifications
CPU	Pentium 200 MHz or more (Pentium 400 MHz or more recommended)
Memory Capacity	64 Mbytes min.
Free Hard Disk Space	500 Mbytes min.
Display	Resolution: 800×600 pixels min. (1024×768 pixels recommended)
Expansion Slot	PCI half-size slot ×1
Interrupt Processing	Single level specifications (IRQ sharing possible)
I/O Memory	32 kbytes shared memory
OS*	Windows 2000 Professional SP1 or later, Windows XP Professional SP1 or later, Windows Vista, Windows 7
Development Language	Microsoft Visual C/C++ 6.0 SP5 or later, Microsoft Visual Basic 6.0 SP5 or later, Microsoft Visual C++ .NET2003, Microsoft Visual Basic .NET2003, Microsoft Visual C++ .NET2005, Microsoft Visual Basic .NET2005, Microsoft Visual C++ .NET2008, Microsoft Visual Basic .NET2008, Microsoft Visual C++ .NET2010, Microsoft Visual Basic .NET2010
Motion Board	MP2100 (model: JAPMC-MC2100-E) , MP2100M (model: JAPMC-MC2140-E) , MP2101 (model: JAPMC-MC2102-E) , MP2101M (model: JAPMC-MC2142-E) , MP2101T (model: JAPMC-MC2102T-E) , MP2101TM (model: JAPMC-MC2142T-E)

* : Only 32-bit versions

■ Motion Related API

Classifications	Commands	Functions	Classifications	Commands	Functions	
Device	All clear for axis definition	ymcClearAllAxes()	Interpolation	Direct interpolation	ymcMoveLinear()	
	Clear for axis definition	ymcClearAxis()		Circular interpolation (specified main coordinate)	ymcMoveCircularCenter()	
	Clear for device	ymcClearDevice()		Circular interpolation (specified radius)	ymcMoveCircularRadius()	
	Device definition	ymcDeclareDevice()		Helical interpolation (specified main coordinate)	ymcMoveHelicalCenter()	
	Axis definition	ymcDeclareAxis()		Helical interpolation (specified radius)	ymcMoveHelicalRadius()	
	Acquisition of axis handle information	ymcGetAxisHandles()		Torque Reference	Torque reference	ymcMoveTorque()
Unit Conversion	Conversion: command unit to floating decimal point	ymcConvertFix2Float()	Gears	Disable gear control	ymcDisableGear()	
	Conversion: floating decimal point to command unit	ymcConvertFix2Fix()		Enable gear control	ymcEnableGear()	
Parameter-related Operations	Acquisition of motion parameter	ymcGetMotionParameter Value()		Setting for gear ratio	ymcSetGearRatio()	
	Setting for motion parameter	ymcSetMotionParameter Value()	Compensation	Compensation: positioning	ymcPositionOffset()	
	Setting for current position	ymcDefinePosition()	Motion-related Operations	Change motion data	ymcChangeDynamics()	
Positioning	Positioning	ymcMovePositioning()		Disable axial execution	ymcStopMotion()	
	JOG feeding	ymcMoveJOG()		Driver-related Operations	Servo ON/OFF setting	ymcServoControl()
	JOG feeding disable	ymcStopJOG()	Others		Disable latch	ymcDisableLatch()
	Origin return operation	ymcMoveHomePosition()			Enable latch	ymcEnableLatch()
	Positioning with specified time	ymcMoveIntimePositioning()		Latch on standby	ymcWaitTime()	
	External positioning	ymcMoveExternalPositioning()				
Positioning for driver	ymcMoveDriverPositioning()					

■ System API

Classifications	Commands	Functions	Classifications	Commands	Functions
Data-related Operations	Setting for bit	ymcSetIoDataBit()	System-related Operations	Specification of controller	ymcOpenController()
	Setting for data	ymcSetIoDataValue()		Release of specified controller	ymcCloseController()
	Acquisition of data	ymcGetIoDataValue()		Change of controller	ymcSetController()
	Setting for register data value	ymcSetRegisterData()		Acquisition of controller	ymcGetController()
	Acquisition of register data value	ymcGetRegisterData()		Acquisition of information on last error for the performed function	ymcGetLastError()
	Acquisition of register data handle	ymcGetRegisterDataHandle()	Calendar-related Operations	Acquisition of controller calendar	ymcGetCalendar()
System-related Information	Acquisition of alarm information	ymcGetAlarm()		Setting of controller calendar	ymcSetCalendar()
	Clear alarm	ymcClearAlarm()	Others	Detection time setting of API timeout	ymcSetAPITimeoutValue()
	Clear system alarm	ymcClearServoAlarm()			

● Control Information Monitoring Tool **MPLOGGER** Model: CPMC-MPG700

■ Hardware and Software Requirements

Items	Specifications
CPU	Pentium II 233 MHz min.
Memory Capacity	64 Mbytes min.
Free Hard Disk Space	1 Gbytes min. when logging, 100 Mbytes min. when not logging
Display	Resolution: 800×600 pixels min.
CD Drive	1 (Network drive can be used.)
OS*	Windows 2000 (SP1 or later), Windows XP (SP2 or later), Windows Vista
Application Programs	Microsoft Excel 97 or later, DAO (Microsoft) Version 3.5, CimScope (Yaskawa's communication driver) Version 0.34 or later.

* : Only 32-bit versions

● Data Transfer Tool **MPLoader** Model: CPMC-MPL700C

■ Hardware and Software Requirements

Items	Specifications
CPU	Pentium 800 MHz or more, or equivalent (1 GHz or more recommended)
Memory Capacity	128 Mbytes or more (256 Mbytes or more recommended)
Free Hard Disk Space	20 Mbytes min.
Display	Resolution: 800×600 pixels min., High Color (16 bits)
OS*	Windows 2000/XP/Vista/7

* : Only 32-bit versions

● OPC Server Model: FA-Server 4.0

■ Hardware and Software Requirements Robotics, Inc.
(<http://www.roboticsware.co.jp>)

Items	Specifications
CPU	Pentium 133 MHz min.
Free Hard Disk Space	30 Mbytes min.
OS*	Windows 98/Me/NT4.0/2000/XP
Development Language	Microsoft Visual Basic, Microsoft Visual C++ (See Roboticsware's website for more information.)

* : Only 32-bit versions

● Compression/Transfer tool for Auto Startup File **MPLoadMaker** Model: CPMC-MPL710

■ Hardware and Software Requirements

Items	PC	
	PC for software development with MPLoadMaker	Target PC
Applicable Machine Controller	MP2100, MP2100M, MP2200, MP2300	
CPU	Pentium 800 MHz or more, or equivalent (1 GHz or more recommended)	
Free Hard Disk Space	More than 25 Mbytes*1 (For one auto startup file)	More than 1 Mbytes*1 (Only for transferring)
Memory Capacity	128 Mbytes or more (256 Mbytes or more recommended)	
Display Resolution	800×600 pixels min.	
OS*2	Windows 2000 (Japanese and English), Windows XP (Japanese and English), Windows Vista (Japanese and English), Windows 7 (Japanese and English)	Windows 2000 (Japanese and English), Windows XP (Japanese and English), Windows Vista (Japanese and English), Windows 7 (Japanese and English)
Communication Interface	–	217IF*3, 218IF*3, USB, MP2100
File Transfer	MAL or YMW files	
Continuous Application Transfer	–	Provided
Hard Disk Space for Installation	30 Mbytes	Installation not required

*1 : Depending on the size of the application file to be transferred.

*2 : Only 32-bit versions

*3 : Cannot be used for relays.

● Communication Middleware **MPScope** Model: CPMC-MPS700

■ Hardware and Software Requirements

Items	Specifications
CPU	Pentium 800 MHz or more, or equivalent (1 GHz or more recommended)
Memory Capacity	128 Mbytes or more (256 Mbytes or more recommended)
Free Hard Disk Space	50 Mbytes min. at system drive
Communication Port	Serial, Ethernet, PCI bus*1, or USB*2
OS*3	Windows XP (SP2 or later), Windows Vista (SP1 or later), Windows 7
Development Language	Microsoft Visual C++ 6.0 Microsoft Visual Basic 6.0 Microsoft Visual C++ .NET Microsoft Visual Basic .NET Microsoft Visual C#

*1 : With MP2100, MP2100M, MP2500, or MP2500M

*2 : With MP2200-02 (CPU-02)

*3 : Only 32-bit versions

Model Designations

For details, refer to each catalog.

● Σ -III Series (Catalog number: KAEP S800000 32)

SERVOPACKs

Σ -III Series SERVOPACK SGDS

Max. Applicable Motor Rated Output

Code	Output	Code	Output	Code	Output
A3	30 W	05	500 W	30	3.0 kW
A5	50 W	08	750 W	50	5.0 kW
01	100 W	10	1.0 kW	60	6.0 kW
02	200 W	15	1.5 kW	75	7.5 kW
04	400 W	20	2.0 kW	-	-

Power Supply Voltage

Code	Power Supply Voltage
A	200 VAC
F	100 VAC [Input: 100 V, Output: 200 V (voltage doubled)]
B	100 VAC [Input: 100 V, Output: 100 V (for SGMMJ motors)]

SGDS - A5 A 01 A □

Mounting Method
Blank : Base-mounted (For models of 7.5 kW or less)
R : Rack-mounted (For models of 5.0 kW or less)

Design Revision Order
A, B ···

Interface Specifications

Code	Specifications	Applicable Servomotors
01	For analog voltage/pulse reference	Rotary servomotors
02	For analog voltage/pulse reference and fully closed control	
12	For MECHATROLINK-II and fully closed control	
05	For analog voltage/pulse reference	Linear servomotors
15	For MECHATROLINK-II	

Servomotors

Σ -III Series Servomotor SGMMJ, SGMAS, SGMPs, SGMSs, SGMGH

Rated Output

Code	Output	Code	Output	Code	Output	Code	Output
A1	10 W	03	300 W	12	1.2 kW*2	44	4.4 kW
A2	20 W	04	400 W	13	1.3 kW	50	5.0 kW
A3	30 W	05	450 W	15	1.5 kW	55	5.5 kW
A5	50 W	06	600 W	20	2.0 kW*3	70	7.0 kW
C2	150 W	08	750 W	25	2.5 kW	75	7.5 kW
01	100 W	09	900 W*1	30	3.0 kW*4	-	-
02	200 W	10	1.0 kW	40	4.0 kW	-	-

* 1 : SGMGH (1500 min⁻¹) : 850 W
* 2 : SGMAS : 1.15 kW
* 3 : SGMGH (1500 min⁻¹) : 1.8 kW
* 4 : SGMGH (1500 min⁻¹) : 2.9 kW

Power Supply Voltage

Code	Voltage	Applicable Models
A	200 VAC	SGMAS*, SGMPs*, SGMSs, SGMGH
B	100 VAC	SGMMJ

* : 200-VAC supply voltage can be used for SGMAS and SGMPs motors even when 100 VAC is used for SERVOPACKs.

Serial Encoder Specifications

Code	Specifications	No. of Pulses
A*1	13-bit Incremental (Standard)	2048P/R
C*2	17-bit Incremental (Standard)	32768P/R
2	17-bit Absolute (Standard)	32768P/R

* 1 : Only for SGMMJ motors.
* 2 : Not for SGMMJ motors.

SGM□□ - 01 A C A 2 1 □

Options (SGMMJ only)

Code	Lead Length	Code	Lead Length
Blank	300 mm	J	1000 mm
H	500 mm	K	1500 mm

Options

Code	Specifications
1	No Option
B	90-VDC Brake
C	24-VDC Brake
D	Oil Seal, 90-VDC Brake
E	Oil Seal, 24-VDC Brake
S	Oil Seal

Note : The model designation for SGMMJ motors will show code 1 or C.

Shaft End Specifications

Code	Specifications	Applicable Models
2	Straight, No key (Standard)*	SGMAS, SGMPs, SGMSs, SGMGH
3	Taper 1/10, Parallel key (Optional)	SGMSs, SGMGH
4	Straight, Key (Optional)	SGMAS, SGMPs
5	Taper 1/10, Woodruff key (Optional)	SGMGH (Only for some models)
6	Straight, Key, Tap (Optional)	SGMAS, SGMPs, SGMSs, SGMGH
8	Straight, Tap (Optional)	SGMAS, SGMPs
A	Straight, Flat (Optional)	SGMMJ

* : Standard for SGMMJ models: straight and no flat.

Design Revision Order

Code	Specifications	Applicable Models
A	Standard	SGMAS, SGMPs, SGMSs, SGMGH (1500 min ⁻¹)
B		SGMMJ, SGMGH (1000 min ⁻¹)
C	For High-precision	SGMGH (1500 min ⁻¹) -05 to -44 only
D	Machinery	SGMGH (1000 min ⁻¹) -03 to -30 only
E	IP67 (Optional)	SGMPs

● Σ -V Series (Catalog number: KAEP S80000 42)

DC Power Input SERVOPACKs

● Analog Voltage Reference/ Pulse Train Reference

Options*1
SGDV - 2R9 E S1 A 000 00 0

Σ -V Series
SGDV SERVOPACK

Current

Code	Applicable Servomotor Max. Capacity W
1R7	11
2R9	30

Power Supply Voltage
E : 24 VDC/48 VDC*2

Interface

Code	Specifications
S1	Analog voltage reference (for rotary servomotors)
P1	Pulse train reference (for rotary servomotors)

Options (parameters)
0 : standard

Options (software)
00 : standard

Options (hardware)

Code	Specifications
000	Encoder pulse dividing output: Line driver (standard)
010	Encoder pulse dividing output: Open collector (only for pulse train reference type)

Design Revision Order
A, B · · ·

*1 : If the option codes are all zeros, zeros are omitted.
*2 : The control power supply is 24 VDC.

● MECHATROLINK-II and III Communications Reference

Options*1
SGDV - 2R9 E 11 A 000 00 0

Σ -V Series
SGDV SERVOPACK

Current

Code	Applicable Servomotor Max. Capacity W
1R7	11
2R9	30

Power Supply Voltage
E : 24 VDC/48 VDC*2

Interface

Code	Specifications
11	MECHATROLINK-II communications reference (for rotary servomotors)
21	MECHATROLINK-III communications reference (for rotary servomotors)

Options (parameters)
0 : standard

Options (software)
00 : standard

Options (hardware)
000 : standard

Design Revision Order
A, B · · ·

*1 : If the option codes are all zeros, zeros are omitted.
*2 : The control power supply is 24 VDC.

AC Servo Drives

● Σ -V Series (Catalog number: KAEP S800000 42)

AC Power Input SERVOPACKS

● Without Option Module

Options*1

SGDV - R70 A 01 A 000 00 0

Σ -V Series
SGDV SERVOPACK

Current

Power Supply Voltage	Code	Applicable Servomotor Max. Capacity kW
Single-phase 100 V	R70	0.05
	R90	0.1
	2R1	0.2
	2R8	0.4
Three-phase 200 V	R70*2	0.05
	R90*2	0.1
	1R6*2	0.2
	2R8*2	0.4
	3R8	0.5
	5R5*2	0.75
	7R6	1.0
	120*3	1.5
	180	2.0
	200	3.0
	330	5.0
	470	6.0
Three-phase 400 V	550	7.5
	590	11
	780	15
	1R9	0.5
	3R5	1.0
	5R4	1.5
	8R4	2.0
	120	3.0
	170	5.0
	210	6.0
260	7.5	
280	11	
370	15	

Options (parameters)
0 : standard

Options (software)
00 : standard

Options (hardware)*4

Code	Specifications
000	Base-mounted (standard)
001	Rack-mounted*5
002	Varnished (Coating equivalent to HumiSeal)
003	Rack-mounted*5 and Varnished
008	Single-phase 200 VAC input (Model: SGDV-120A□□A008000)
020	Dynamic brake (DB)*6

Design Revision Order
A, B · · ·

Interface

Code	Specifications
01	Analog voltage/pulse train reference (for rotary servomotors)
05	Analog voltage/pulse train reference (for linear servomotors)
11	MECHATROLINK-II communications reference (for rotary servomotors)
15	MECHATROLINK-II communications reference (for linear servomotors)
21	MECHATROLINK-III communications reference (for rotary servomotors)
25	MECHATROLINK-III communications reference (for linear servomotors)
E1	Command option attachable type*7 (for rotary servomotors)
E5	Command option attachable type*7 (for linear servomotors) (Under development)

Power Supply Voltage
F : Single-phase 100 VAC
A : Three-phase 200 VAC
D : Three-phase 400 VAC

*1 : If the option codes are all zeros, zeros are omitted.
*2 : These amplifiers can be powered with single or three-phase.
*3 : Single-phase 200 VAC SERVOPACKs are also available. (Model: SGDV-120A□□A008000)
*4 : Contact your Yaskawa representative for information on combining options.
*5 : Models with a capacity of 6 kW or more have ducts for ventilation.
*6 : An internal resistor for the dynamic brake is not included. An external resistor for the dynamic brake can only be used with 400V SERVOPACKs.
*7 : Be sure to use command option modules for the command option attachable type SERVOPACKs. They will not work without the modules.

● With Option Module

Option Modules*1

SGDV^(Note) R70 A 01 A 000 00 0 001

Σ-V Series
SGDV SERVOPACK

Current

Power Supply Voltage	Code	Applicable Servomotor Max. Capacity kW
Single-phase 100 V	R70	0.05
	R90	0.1
	2R1	0.2
	2R8	0.4
Three-phase 200 V	R70*2	0.05
	R90*2	0.1
	1R6*2	0.2
	2R8*2	0.4
	3R8	0.5
	5R5*2	0.75
	7R6	1.0
	120*3	1.5
	180	2.0
	200	3.0
	330	5.0
	470	6.0
	550	7.5
	590	11
780	15	
Three-phase 400 V	1R9	0.5
	3R5	1.0
	5R4	1.5
	8R4	2.0
	120	3.0
	170	5.0
	210	6.0
	260	7.5
	280	11
	370	15

Option Modules

Code	Specifications	Code	Specifications
001	Fully-closed module	100	INDEXER module
010	Safety module	101	INDEXER + fully-closed modules

Options (parameters)
0 : standard

Options (software)
00 : standard

Options (hardware)*4

Code	Specifications
000	Base-mounted (standard)
001	Rack-mounted*5
002	Varnished (Coating equivalent to HumiSeal)
003	Rack-mounted*5 and Varnished
008	Single-phase 200 VAC input (Model: SGDV-120A□□A008000)
020	Dynamic brake (DB)*6

Design Revision Order
A, B · · ·

Interface

Code	Specifications
01	Analog voltage/pulse train reference (for rotary servomotors)
05	Analog voltage/pulse train reference (for linear servomotors)
11	MECHATROLINK-II communications reference (for rotary servomotors)
15	MECHATROLINK-II communications reference (for linear servomotors)
21	MECHATROLINK-III communications reference (for rotary servomotors)
25	MECHATROLINK-III communications reference (for linear servomotors)
E1	Command option attachable type*7 (for rotary servomotors)
E5	Command option attachable type*7 (for linear servomotors) (Under development)

Power Supply Voltage
F : Single-phase 100 VAC
A : Three-phase 200 VAC
D : Three-phase 400 VAC

- * 1 : Although more than one option module can be attached, certain combinations cannot be used.
 - * 2 : These amplifiers can be powered with single or three-phase.
 - * 3 : Single-phase 200 VAC SERVOPACKs are also available. (Model: SGDV-120A□□A008000)
 - * 4 : Contact your Yaskawa representative for information on combining options.
 - * 5 : Models with a capacity of 6 kW or more have ducts for ventilation.
 - * 6 : An internal resistor for the dynamic brake is not included. An external resistor for the dynamic brake can only be used with 400V SERVOPACKs.
 - * 7 : Be sure to use command option modules for the command option attachable type SERVOPACKs. They will not work without the modules.
- Note : The model number of a SERVOPACK with an option module is not hyphenated after SGDV.

AC Servo Drives

● Σ -V Series (Catalog number: KAEP S800000 42)

Rotary Servomotors

SGMMV

SGMMV - A1 A 2 A 2 1

Σ -V mini Series Servomotor
SGMMV

Rated Output
B3 : 3.3W A1 : 10W
B5 : 5.5W A2 : 20W
B9 : 11W A3 : 30W

Power Supply Voltage
A : 200 VAC*1
E : 24 VDC/48 VDC*2

Serial Encoder
2 : 17-bit absolute

Options
1 : Without options
C : With holding brake (24 VDC)*1

Shaft End
2 : Straight (standard)
A : Straight with a flat seat (optional)

Design Revision Order
A : Standard

*1 : □25 mm flange model only
*2 : For both 24 VDC and 48 VDC. The characteristic value changes according to the SERVOPACK circuit's voltage.

SGMGV, SGMSV

SGMGV - 10 A D A 2 1

Σ -V Series
SGMGV, SGMSV

Rated Output

SGMGV		SGMSV	
Code	Rated Output kW	Code	Rated Output kW
03	0.3	10	1.0
05	0.45	15	1.5
09	0.85	20	2.0
13	1.3	25	2.5
20	1.8	30	3.0
30	2.9	40	4.0
44	4.4	50	5.0
55	5.5	70	7.0*
75	7.5		
1A	11		
1E	15		

* : Available only for 200 VAC models.

Power Supply Voltage
A : 200 VAC
D : 400 VAC

Options
1 : Without options
B : With holding brake (90 VDC)
C : With holding brake (24 VDC)
D : With oil seal and holding brake (90 VDC)
E : With oil seal and holding brake (24 VDC)
S : With oil seal

Shaft End
2 : Straight without key (standard)
A : Straight with key and tap (optional)

Design Revision Order
A : Standard

Serial Encoder
3 : 20-bit absolute (standard)
D : 20-bit incremental (standard)

SGMJV, SGMAV

Without Gears

SGM□V - 01 A D A 2 1

Σ -V Series Servomotor
SGMJV, SGMAV

Rated Output
A5 : 50W 04 : 400W
01 : 100W 06*1 : 600W
C2 : 150W 08 : 750W
02 : 200W 10*2 : 1.0kW

*1 : 550W for SGMAV servomotors
*2 : For SGMAV servomotor only

Power Supply Voltage
A : 200 VAC

Serial Encoder
3 : 20-bit absolute (standard)
D : 20-bit incremental (standard)
A* : 13-bit incremental (standard)

* : For SGMJV servomotor only

Options
1 : Without options
C : With holding brake (24 VDC)
E : With oil seal and holding brake (24 VDC)
S : With oil seal

Shaft End
2 : Straight without key (standard)
6 : Straight with key and tap (optional)
B : With two flat seats (optional)

Design Revision Order
A : Standard

SGMPS

Without Gears

SGMPS - 01 A C A 2 1 - E

Σ -V Series Servomotor
SGMPS

Rated Output
01 : 100W
02 : 200W
04 : 400W
08 : 750W
15 : 1.5kW

Power Supply Voltage
A : 200 VAC

Serial Encoder
2 : 17-bit absolute (standard)
C : 17-bit incremental (standard)

RoHS Directive
E : RoHS Compliant

Options
1 : Without options
C : With holding brake (24 VDC)
E : With oil seal and holding brake (24 VDC)
S : With oil seal

Shaft End
2 : Straight without key (standard)
6 : Straight with key and tap (optional)

Design Revision Order
A : IP55 (standard)
E : IP67 (optional)

● With Gears

SGM□V - 01 A D A H 1 2 1

Σ -V Series Servomotor
SGMJV, SGMAV

Rated Output
(Same as for that without gears)

Power Supply Voltage
(Same as for that without gears)

Serial Encoder
(Same as for that without gears)

Design Revision Order
(Same as for that without gears)

Gear Type
H : HDS planetary low-backlash gear

Options
1 : Without options
C : With holding brake (24 VDC)

Shaft End
0 : Flange output
2 : Straight without key
6 : Straight with key and tap

Gear Ratio
B : 1/11 (Not available: 50 W)
C : 1/21
1 : 1/5
2 : 1/9 (Only 50 W)
7 : 1/33

● With Gears

SGMPS - 01 A 2 A H B 0 1 - E

Σ -V Series Servomotor
SGMPS

Rated Output
(Same as for that without gears)

Power Supply Voltage
(Same as for that without gears)

Serial Encoder
(Same as for that without gears)

Design Revision Order
A : IP55 (standard)

Gear Type
H : HDS planetary low-backlash gear

RoHS Directive
E : RoHS Compliant

Options
1 : Without holding brake
C : With holding brake (24 VDC)

Shaft End
0 : Flange output
2 : Straight without key
6 : Straight with key and tap (optional)

Gear Ratio
B : 1/11
C : 1/21
1 : 1/5
7 : 1/33

● Σ -V Series of Large-Capacity AC Servo Drives (Catalog number: KAEP S800000 86)

SERVOPACKs

SGDV - 750 J 01 A 000 00 0

Σ -V Series SERVOPACK
SGDV

Current

Power Supply Voltage	Code	Applicable Servomotor Max. Capacity kW
Three-phase 200 V	121	22
	161	30
	201	37
Three-phase 400 V	750	30
	101	37
	131	55

Power Supply Voltage*2
H : 200 V class
J : 400 V class

Interface

Code	Specifications
01	Analog voltage/pulse train reference (for rotary servomotors)
11	MECHATROLINK-II communications reference (for rotary servomotors)
21	MECHATROLINK-III communications reference (for rotary servomotors)
E1	Command option attachable type (for rotary servomotors)*3

Options*1

Options (Parameters)
0 : Standard

Options (Software)
00 : Standard

Options (Hardware)

Code	Specifications
000	Base-mounted (Standard)
001	Duct-ventilated
002	Varnished
003	Duct-ventilated and varnished

Design Revision Order
A, B ···

*1 : If the option codes are all zeros, the zeros are omitted.
*2 : DC power from the Separate converter unit.
*3 : To be released soon.

Converter

SGDV - COA 3ZD A 000

Σ -V Series

Product Section

Code	Specifications
COA	Resistive regenerative converter

Current Capacity

Power Supply Voltage	Code	Applicable Servomotor Max. Capacity kW
Three-phase 200 V	2BA	22
	3GA	37
Three-phase 400 V	3ZD	30
	5ED	55

Options*

Options (Hardware)

Code	Specifications
000	Base-mounted (standard)
001	Duct-ventilated
002	Varnished
003	Duct-ventilated and varnished

Design Revision Order
A, B ···

* : If the option codes are all zeros, the zeros are omitted.

Servomotor

SGMVV - 2B A D B 2 N

Σ -V Series Servomotor
SGMVV

Motor Output

2B : 22kW 4E : 45kW
3Z : 30kW 5E : 55kW
3G : 37kW

Power Supply Voltage
A : 200 VAC
D : 400 VAC

Serial Encoder
D : 20-bit incremental
3 : 20-bit absolute

Other Specifications

N : Standard (no other specification) C : Holding brake (24 VDC)
1 : Dust seal D : Oil seal and holding brake (90 VDC)
S : Oil seal E : Oil seal and holding brake (24 VDC)
B : Holding brake (90 VDC) F : Dust seal and holding brake (90 VDC)
G : Dust seal and holding brake (24 VDC)

Motor Specifications

2 : Flange mounted, straight shaft (without key and no tap)
6 : Flange mounted, straight shaft (with key and tap)
K : Foot mounted, straight shaft (without key and no tap)
L : Foot mounted, straight shaft (with key and tap)

Rated Motor Speed

B : 1500 min⁻¹
D : 800 min⁻¹

AC Servo Drives

● JUNMA Series (Applicable for MECHATROLINK-II) (Catalog number: KAEP S800000 41)

SERVOPACKs

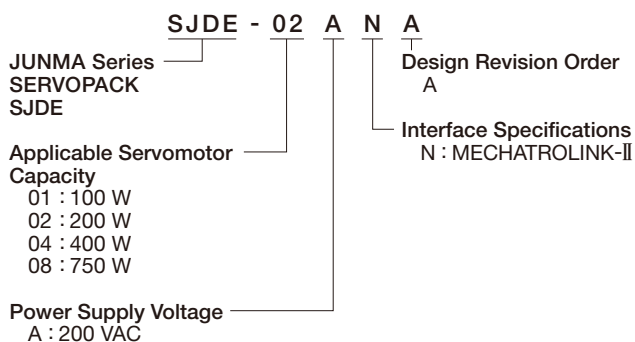

Servomotors

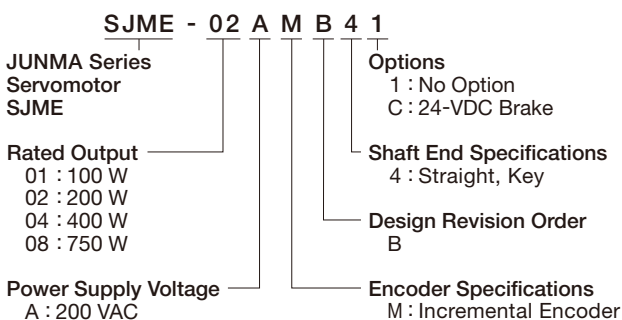

● Direct-drive Σ Series

(Catalog number: KAEP S800000 06)

SERVOPACKs

Σ -III SGDS (Refer to page 74.)

Σ -V SGDV (Refer to page 76 and 77.)

Servomotors

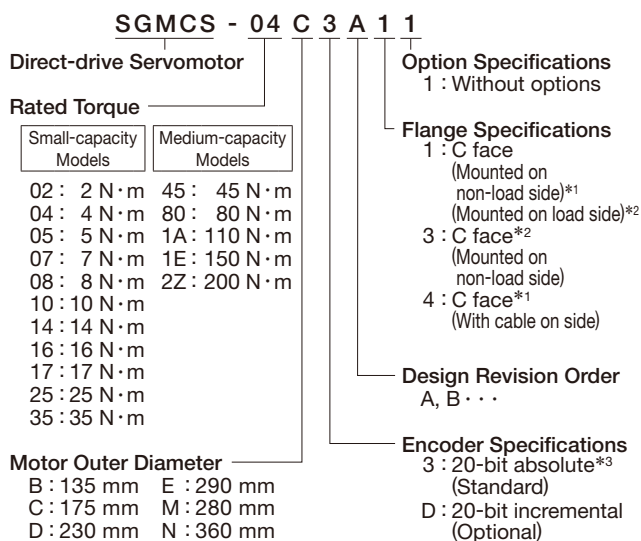

*1 : Only for small-capacity models.
 *2 : Only for medium-capacity models.
 *3 : Without multiturn data

● Linear Σ Series

SERVOPACKs

Σ -III SGDS (Refer to page 74.)
 (Catalog number: KAEP S800000 32)

Σ -V SGDV (Refer to page 76 and 77.)
 (Catalog number: KAEP S800000 42)

Servomotors

● Moving Coils

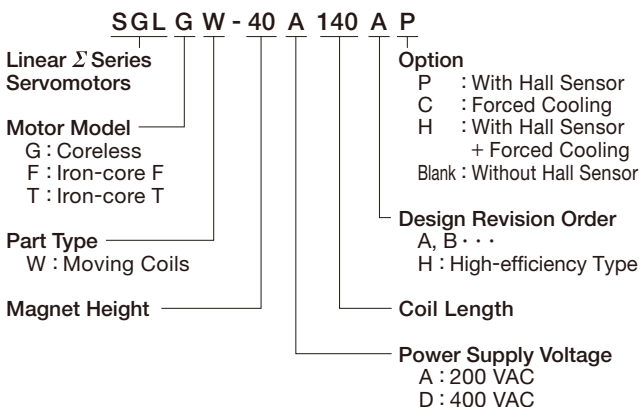

● Magnetic Way

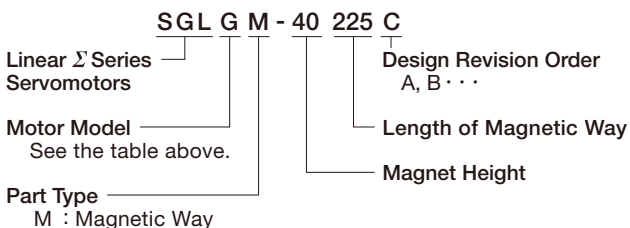

● Σ -Stick Series (Catalog number: KAEP S800000 33)

SERVOPACKs

Σ -III SGDS (Refer to page 74.)

Σ -V SGD V (Refer to page 76 and 77.)

Servomotors (Integrated Model)

● Moving Coils and Magnetic Way

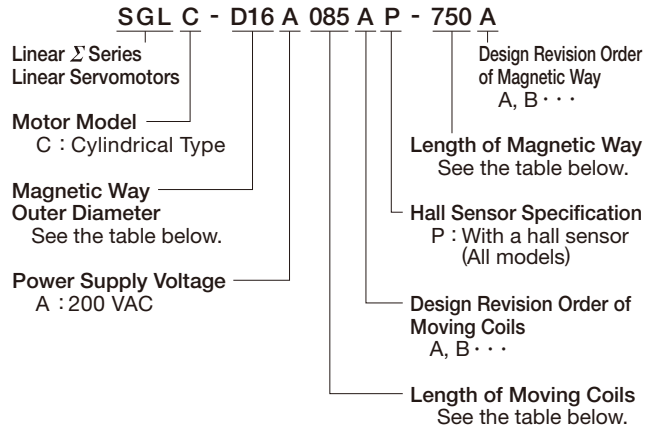

Servomotors (Non-integrated Model)

● Moving Coils

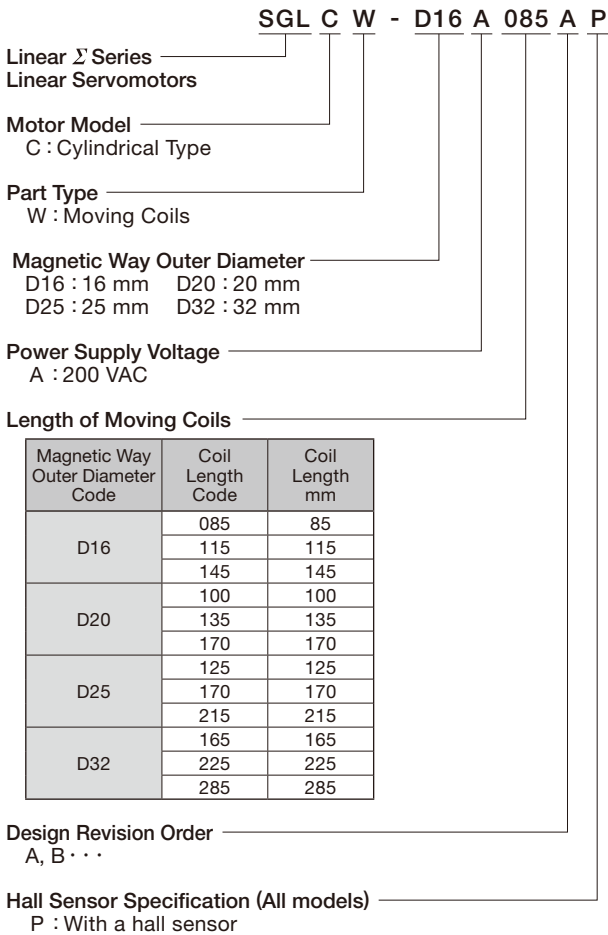

● Magnetic Way

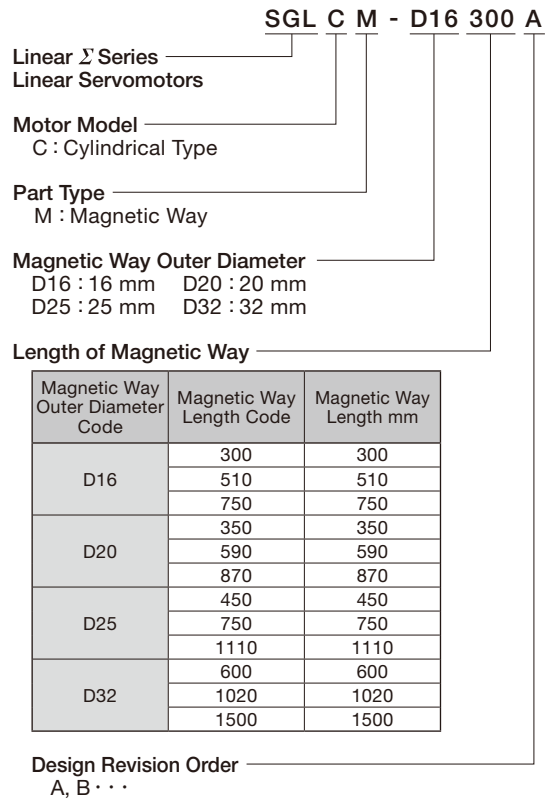

Note : An integrated model is the standard model when ordering a servomotor from the Σ -Stick series.
Contact your Yaskawa representative to order a servomotor with only moving coils or a magnetic way.

Ordering Reference

Order List

Notes :1 If the model number has "-E", the product is compliant with RoHS directives.

2 If the model number has "(-E)", both RoHS-compliant and non RoHS-compliant products are available. Contact your Yaskawa representative for details.

● Controller Main Units, Modules, and Support Tools

Classifications	Products	Model Name	Model	Specifications	Qty	
Machine Controller Main Units	MP2100 board ^(Note)	MP2100	JAPMC-MC2100-E	1 channel for MECHATROLINK-II, 5-point input and 4-point output		
	MP2100M board ^(Note)	MP2100M	JAPMC-MC2140-E	2 channels for MECHATROLINK-II, 5-point input and 4-point output		
	MP2101 board ^(Note)	MP2101	JAPMC-MC2102-E	High-speed MP2100 1 channel for MECHATROLINK-II, 5-point input and 4-point output		
	MP2101M board ^(Note)	MP2101M	JAPMC-MC2142-E	High-speed MP2100M 2 channels for MECHATROLINK-II, 5-point input and 4-point output		
	MP2101T board ^(Note)	MP2101T	JAPMC-MC2102T-E	High-speed MP2100, Compatible with M-III 1 channel for MECHATROLINK-III, 5-point input and 4-point output		
	MP2101TM board ^(Note)	MP2101TM	JAPMC-MC2142T-E	High-speed MP2100M, Compatible with M-III 2 channels for MECHATROLINK-III, 5-point input and 4-point output		
	MP2200 base unit ^(Note)	MBU-01	JEPMC-BU2200-E	100 VAC/200 VAC input base unit (9 slots)		
		MBU-02	JEPMC-BU2210-E	24 VDC input base unit (9 slots)		
		MBU-03	JEPMC-BU2220-E	24 VDC input base unit (4 slots)		
	MP2300 basic module (CPU module included)	MP2300	JEPMC-MP2300-E	24 VDC input, 1 channel for MECHATROLINK-II, I/O · A battery (JZSP-BA01) for backup data is provided.		
	MP2310 basic module	MP2310	JEPMC-MP2310-E	24 VDC input, 1 channel for MECHATROLINK-II, 1 channel for Ethernet (100 Mbps) · A battery (JZSP-BA01) for backup data is provided.		
	MP2300S basic module	MP2300S	JEPMC-MP2300S-E	1 channel for MECHATROLINK-II, 1 channel for Ethernet (100 Mbps) 1-point output · A battery (JZSP-BA01) for backup data is provided. · One terminator [JEPMC-W6022 (-E)] is provided. · One set of fixtures for mounting a module on DIN rail (JEPMC-OP300) is provided.		
	MP2400 module	MP2400	JEPMC-MP2400-E	1 channel for MECHATROLINK-II, 1 channel for Ethernet (100 Mbps) 1-point output · A battery (JZSP-BA01) for backup data is provided.		
	MP2500	MP2500	JEPMC-MP2500-NP0-E	15-inch panel integrated type, 1 channel for MECHATROLINK-II		
			JEPMC-MP2500-NP1-E	12.1-inch panel integrated type, 1 channel for MECHATROLINK-II		
	MP2500M	MP2500M	JEPMC-MP2540-NP0-E	15-inch panel integrated type, 2 channels for MECHATROLINK-II		
			JEPMC-MP2540-NP1-E	12.1-inch panel integrated type, 2 channels for MECHATROLINK-II		
			JEPMC-MP254E-NP0-E	15-inch panel integrated type, 2 channels for MECHATROLINK-II + EXIOIF		
			JEPMC-MP254E-NP1-E	12.1-inch panel integrated type, 2 channels for MECHATROLINK-II + EXIOIF		
	MP2500B	MP2500B	JEPMC-MP2500-NB0-E	Separated PC Box, 1 channel for MECHATROLINK-II		
	MP2500MB	MP2500MB	JEPMC-MP2540-NB0-E	Separated PC Box, 2 channels for MECHATROLINK-II		
	MP2500B-OP	MP2500B-OP	JEPMC-MP250U-NB0-E	Separated PC Box, 1 channel for MECHATROLINK-II + Spare slot × 1*1		
	MP2500MB-OP	MP2500MB-OP	JEPMC-MP254U-NB0-E	Separated PC Box, 2 channels for MECHATROLINK-II + Spare slot × 1*1		
	For MP2500	10.4-inch touch panel	PNL-10	JEPMC-OP25PNL-10-E	For panel-separated type, 10.4-inch touch panel	
		12.1-inch touch panel	PNL-12	JEPMC-OP25PNL-12-E	For panel-separated type, 12.1-inch touch panel	
		LVDS cable : 25 cm	LVDS-A25	JEPMC-OP25LV-A25-E	Monitor cable for panel-separated type: 25 cm	
		LVDS cable : 3 m	LVDS-03	JEPMC-OP25LV-03-E	Monitor cable for panel-separated type: 3 m	
LVDS cable : 10 m		LVDS-10	JEPMC-OP25LV-10-E	Monitor cable for panel-separated type: 10 m		
CPU Module	CPU-01 module	CPU-01	JAPMC-CP2200-E	CPU for MP2200 · A battery (JZSP-BA01) for backup data is provided.		
	CPU-02 module	CPU-02	JAPMC-CP2210-E	CPU module for MP2200, with CF card slot and USB port · A battery (JZSP-BA01) for backup data is provided.		
	CPU-03 module	CPU-03	JAPMC-CP2220-E	CPU module for MP2200, with CF card slot, 1 channel for Ethernet (100 Mbps) · A battery (JZSP-BA01) for backup data is provided.		
	CPU-04 module	CPU-04	JAPMC-CP2230-E	High-speed CPU for MP2200, 1 channel for Ethernet (100 Mbps) · A battery (JZSP-BA01) for backup data is provided.		
	MPU-01 module	MPU-01	JAPMC-CP2700-E	Module with CPU and SVC-01 functions, 1 channel for MECHATROLINK-III		

*1 : One MP2000-series optional module can be mounted in the spare slot.

Note: Battery (JZSP-BA01) for backup data is sold separately.

Classifications	Products	Model Name	Model	Specifications	Qty
Connection Module	Expansion interface module	EXIOIF	JAPMC-EX2200-E	Expansion interface for MP2200	
	Expansion interface board	MP2100MEX	JAPMC-EX2100-E	Expansion interface board for MP210□M and MP2500M	
	Repeater	–	JEPMC-REP2000-E	MECHATROLINK-II repeater	
Motion Modules	Motion control module	SVB-01	JAPMC-MC2310-E	1 channel for MECHATROLINK-II	
		SVC-01	JAPMC-MC2320-E	1 channel for MECHATROLINK-III	
	Analog motion control module	SVA-01	JAPMC-MC2300	Analog-output 2-axis servo control	
	Pulse Output Motion Control Module	PO-01	JAPMC-PL2310-E	Pulse-output, 4-axis servo control	
Communication Modules	General-purpose serial communication module	217IF-01	JAPMC-CM2310-E	RS-232C/RS-422 communication	
	Ethernet communication module	218IF-01	JAPMC-CM2300-E	RS-232C/Ethernet communication	
		218IF-02	JAPMC-CM2302-E	RS-232C/Ethernet (100 Mbps) communications	
	DeviceNet communication module	260IF-01	JAPMC-CM2320-E	RS-232C/DeviceNet communication	
	PROFIBUS communication module	261IF-01	JAPMC-CM2330-E	RS-232C/PROFIBUS communication	
	FL-net communication module	262IF-01	JAPMC-CM2303-E	Cyclic transmission and message transmission	
	EtherNet / IP communication module	263IF-01	JAPMC-CM2304-E	I/O transmission and Explicit message transmission	
	EtherCAT communication module	264IF-01	JAPMC-CM2305-E	As a slave station of EtherCAT	
	CompoNet communication module	265IF-01	JAPMC-CM2390-E	CompoNet communication	
	PROFINET communication module	266IF-01*2	JAPMC-CM2306-E	PROFINET master	
		266IF-02	JAPMC-CM2307-E	PROFINET slave	
	MPLINK communication module	215AIF-01 MPLINK	JAPMC-CM2360-E	RS-232C/MPLINK communication	
CP-215 communication module	215AIF-01 CP-215	JAPMC-CM2361	RS-232C/CP-215 communication		
I/O Modules	I/O module	LIO-01	JAPMC-IO2300-E	16-point input, 16-point output (sink mode output), pulse input: 1 channel	
		LIO-02	JAPMC-IO2301-E	16-point input, 16-point output (source mode output), pulse input: 1 channel	
		LIO-04	JAPMC-IO2303-E	32-point input and 32-point output (sink mode output)	
		LIO-05	JAPMC-IO2304-E	32-point input and 32-point output (source mode output)	
		LIO-06	JAPMC-IO2305-E	Digital input: 8 points, digital output: 8 points, analog input: 1 channel, analog output: 1 channel, pulse counter: 1 channel	
	Output module	DO-01	JAPMC-DO2300-E	64-point output (sink mode output)	
	Analog input module	AI-01	JAPMC-AN2300-E	8 channels for analog input	
	Analog output module	AO-01	JAPMC-AN2310-E	4 channels for analog output	
	Counter module	CNTR-01	JAPMC-PL2300-E	2 channels, selection of 2 input circuits: 5-V differential or 12 V.	
Distributed I/O Modules (I/O Modules for MECHATROLINK-II)	64-point I/O module	IO2310	JEPMC-IO2310-E	64-point input and 64-point output (sink mode output)	
		IO2330	JEPMC-IO2330-E	64-point input and 64-point output (source mode output)	
	Counter module	PL2900	JEPMC-PL2900-E	Reversible counter: 2 channels	
	Pulse output module	PL2910	JEPMC-PL2910-E	Pulse output: 2 channels	
	Analog input module	AN2900	JEPMC-AN2900-E	Analog input: –10 V to +10 V, 4 channels	
	Analog output module	AN2910	JEPMC-AN2910-E	Analog output: –10 V to +10 V, 2 channels	
	16-point input module	IO2900-E	JAMSC-IO2900-E	16-point input	
	16-point output module	IO2910-E	JAMSC-IO2910-E	16-point output (sink mode output)	
	8-point I/O module	IO2920-E	JAMSC-IO2920-E	8-point input and 8-point output (sink mode output)	
Relay output module	IO2950-E	JAMSC-IO2950-E	8 contact outputs		
MECHATROLINK-III Compatible Modules	Hub module	HUB	JEPMC-MT2000-E	–	
	Network analyzer module	MTNA-01	JEPMC-MT2010-E	–	
	Network adapter module	MTNA-02	JEPMC-MT2020-E	–	
	64-point I/O module	MTD2310	JEPMC-MTD2310-E	64-point input and 64-point output (sink mode output)	
	Analog Input Module	MTA2900	JEPMC-MTA2900-E	Analog input: 8 channels	
	Analog Output Module	MTA2910	JEPMC-MTA2910-E	Analog output: 4 channels	
	Pulse Input Module	MTP2900	JEPMC-MTP2900-E	Pulse input: 2 channels	
Pulse Output Module	MTP2910	JEPMC-MTP2910-E	Pulse output: 4 channels		
Engineering Tool	Integrated Engineering Tool MPE720 version 6*3	–	CPMC-MPE770	<ul style="list-style-type: none"> The programming software to support you from system design to maintenance Intuitive ladder programming and editing functions Cam data generations 	
	System Integrated Engineering Tool MPE720 version 7*3	–	CPMC-MPE780	<ul style="list-style-type: none"> MPE720 Ver.6 : Applicable for Windows 2000(SP1 or later)/XP/Vista/7. MPE720 Ver.7 : Applicable for Windows XP/Vista/7. Note: MPE720 is not available with machine controllers in the MP900 series.	

*2 : Estimates are required before ordering this product. Contact your Yaskawa representative for more information.



Ordering Reference



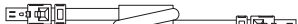
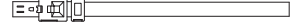

● Controller Main Units, Modules, and Support Tools (Cont'd)

Classifications	Products	Model Name	Model	Specifications	Qty
API	Motion API*3	–	CPMC-MPA700	Header file, library, DLL, driver, and manual	
Screen-creation Tool	MotionScreen Builder*3	–	CPMC-MPMS700B	<ul style="list-style-type: none"> • For MP2500 and MP2500M • For HMI development without programming • Provides API for VC. 	
Controller Data Monitoring Tool	MPLOGGER*3	–	CPMC-MPG700	Monitors the machine-controller data on an Excel sheet.	
Data Transfer Tool	MPLoader*3	–	CPMC-MPL700C	Loads data to Machine Controller without using MPE720.	
Automatic Compression/Transfer Tool	MPLoadMaker*3	–	CPMC-MPL710	Creates an auto transfer file with application data.	
Communication Middleware	MPScope*3	–	CPMC-MPS700	Acts as middleware between the MP2000 Series Machine Controller and the host PC, so a COM interface can be used to execute the functions for the register operations even if data is received from a variety of communications networks.	
Analyzer Tool	Network Analyzer Tool	–	CMPC-NWAN710	A software program used to set parameters for a Network Analyzer module and monitor the module.	

*3 : Only one license is provided for each product, so only one set can be installed on one personal computer.



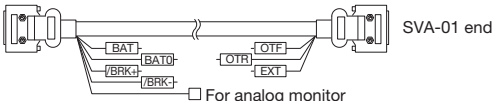
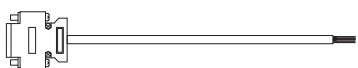

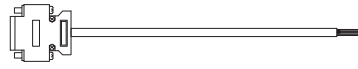
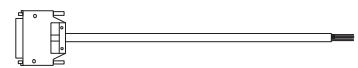



● Cables and Connectors

Name	Model	Length m	Specifications	Qty
Cable for MECHATROLINK-III	JEPMC-W6012-A2-E	0.2	With MECHATROLINK-III connectors on both ends 	
	JEPMC-W6012-A5-E	0.5		
	JEPMC-W6012-01-E	1.0		
	JEPMC-W6012-02-E	2.0		
	JEPMC-W6012-03-E	3.0		
	JEPMC-W6012-04-E	4.0		
	JEPMC-W6012-05-E	5.0		
	JEPMC-W6012-10-E	10.0		
	JEPMC-W6012-20-E	20.0		
	JEPMC-W6012-30-E	30.0		
	JEPMC-W6012-50-E	50.0		
	JEPMC-W6013-10-E	10.0	With ring core 	
	JEPMC-W6013-20-E	20.0		
	JEPMC-W6013-30-E	30.0		
	JEPMC-W6013-50-E	50.0		
	JEPMC-W6013-75-E	75.0		
	JEPMC-W6014-A5-E	0.5	With a connector on the controllers end 	
	JEPMC-W6014-01-E	1.0		
	JEPMC-W6014-03-E	3.0		
	JEPMC-W6014-05-E	5.0		
JEPMC-W6014-10-E	10.0			
JEPMC-W6014-30-E	30.0			
JEPMC-W6014-50-E	50.0			
Cable for MECHATROLINK-II and MPLINK	JEPMC-W6002-A5-E	0.5		With connectors on both ends 
	JEPMC-W6002-01-E	1.0		
	JEPMC-W6002-03-E	3.0		
	JEPMC-W6002-05-E	5.0		
	JEPMC-W6002-10-E	10.0		
	JEPMC-W6002-20-E	20.0		
	JEPMC-W6002-30-E	30.0		
	JEPMC-W6002-40-E	40.0		
	JEPMC-W6002-50-E	50.0		
	JEPMC-W6003-A5-E	0.5	With ring core 	
	JEPMC-W6003-01-E	1.0		
	JEPMC-W6003-03-E	3.0		
	JEPMC-W6003-05-E	5.0		
	JEPMC-W6003-10-E	10.0		
	JEPMC-W6003-20-E	20.0		
	JEPMC-W6003-30-E	30.0		
	JEPMC-W6003-40-E	40.0		
	JEPMC-W6003-50-E	50.0		

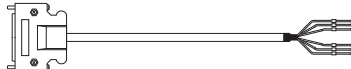
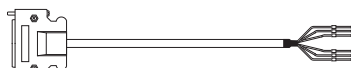



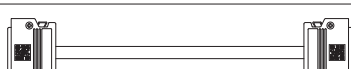
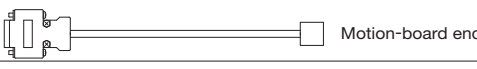



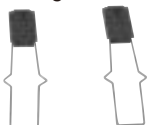

Name	Model	Length m	Specifications	Qty
MPLINK Cable	JEPMC-W6011-A5	0.5	With a connector on the controller end Notes: 1 Never use these cables with MECHATROLINK-II. 2 When the MP2000 Series Machine Controller is connected to a Σ -I series servodrives, use these cables. 	
	JEPMC-W6011-01	1.0		
	JEPMC-W6011-03	3.0		
	JEPMC-W6011-05	5.0		
	JEPMC-W6011-10	10.0		
	JEPMC-W6011-20	20.0		
	JEPMC-W6011-30	30.0		
	JEPMC-W6011-40	40.0		
	JEPMC-W6011-50	50.0		
Terminator	JEPMC-W6022-E	-	For MECHATROLINK-II 	
Ring Core	JEPMC-W6021-E	-	For MECHATROLINK-II cable 	
Connection Cable for SVA-01	JEPMC-W2040-A5-E	0.5	With connectors on both ends 	
	JEPMC-W2040-01-E	1.0		
	JEPMC-W2040-03-E	3.0		
	JEPMC-W2041-A5-E	0.5	With a connector on the controller end 	
	JEPMC-W2041-01-E	1.0		
	JEPMC-W2041-03-E	3.0		
RS-232C Communication Cable (217IF-01, 218IF-01, 260IF-01, 261IF-01, and 215AIF-01)	JEPMC-W5311-03-E	2.5	Connection cable for MPE720-installed PC PC side: D-sub, 9-pin, and female  Communication module side: D-sub, 9-pin, and male 	
	JEPMC-W5311-15-E	15.0		
RS-422/485 Communication Cable for 217IF-01	No ready-made cable available. Prepare a cable that meets these specifications. : Connector : 10114-3000PE made by Sumitomo 3M Co., Ltd. Shell : 10314-52A0-008 made by Sumitomo 3M Co., Ltd. Cable : Max. length 300 m, shielded (Use shielded cable and a modem to reduce noise.)			
Ethernet Communication Cable for 218IF-01	Use 10Base-T cross or straight cables.			
DeviceNet Communication Cable for 260IF-01	Use DeviceNet cables. Refer to the ODVA-J web site. (http://www.odva.astem.or.jp/)			
PROFIBUS Communication Cable for 261IF-01	Use PROFIBUS cables. Refer to the PROFIBUS web site (http://www.profibus.jp/). Make sure the cable outlet position and direction so that it will not stand in the way of the RS-232C connector connection when selecting a cable.			
CP-215 Communication Cable for 215AIF-01	No ready-made cable available. Prepare a cable that meets these specifications.: Wire: YS-IPEV-SB (75Ω) or YS-IPEV-S (77Ω) made by Fujikura Ltd. Connector on module end: MR-8RFA4 (G) made by Honda Tsushin Kogyo, Co., Ltd. Connector on cable end: MR-8M (G) made by Honda Tsushin Kogyo, Co., Ltd.			
I/O Cable for MP2300	JEPMC-W2060-A5-E	0.5	With a connector on the MP2300 end 	
	JEPMC-W2060-01-E	1.0		
	JEPMC-W2060-03-E	3.0		
I/O Cable for LIO-01 and LIO-02	JEPMC-W2061-A5-E	0.5	With a connector on the LIO-01/-02 end 	
	JEPMC-W2061-01-E	1.0		
	JEPMC-W2061-03-E	3.0		

Ordering Reference

● Cables and Connectors (Cont'd)

Name	Model	Length m	Specifications	Qty
I/O Cable for LIO-04, LIO-05, DO-01, and PO-01	JEPMC-W6060-05-E	0.5	With a connector on the LIO-04/LIO-05/DO-01 end 	
	JEPMC-W6060-10-E	1.0		
	JEPMC-W6060-30-E	3.0		
I/O cable for LIO-06	JEPMC-W2064-A5-E	0.5	With a connector on the LIO-06 end, 50 pins (With shielded wire) 	
	JEPMC-W2064-01-E	1.0		
	JEPMC-W2064-03-E	3.0		
Input Cable for AI-01	JEPMC-W6080-05-E	0.5	With a connector on the AI-01 end 	
	JEPMC-W6080-10-E	1.0		
	JEPMC-W6080-30-E	3.0		
Output Cable for AO-01	JEPMC-W6090-05-E	0.5	With a connector on the AO-01 end 	
	JEPMC-W6090-10-E	1.0		
	JEPMC-W6090-30-E	3.0		
I/O Cable for CNTR-01	JEPMC-W2063-A5-E	0.5	With a connector on the CNTR-01 end 	
	JEPMC-W2063-01-E	1.0		
	JEPMC-W2063-03-E	3.0		
EXIOIF Cable	JEPMC-W2091-A5-E	0.5	With connectors on both ends 	
	JEPMC-W2091-01-E	1.0		
	JEPMC-W2091-2A5-E	2.5		
I/O Cable for MP2100 (M), MP2101 (M), MP2101T (M), MP2500 (B), and MP2500M (B)	JEPMC-W2062-A5-E	0.5	With a connector on the controller end. 	
	JEPMC-W2062-01-E	1.0		
	JEPMC-W2062-03-E	3.0		
I/O Cable for IO2310 and IO2330	JEPMC-W5410-05-E	0.5	With a connector on the IO2310/IO2330 end 	
	JEPMC-W5410-10-E	1.0		
	JEPMC-W5410-30-E	3.0		
LVDS cable for MP2500B and MP2500MB (For panel-separated types only)	JEPMC-OP25LV-A25-E	0.25	Cable for connecting a panel-separated module 	
	JEPMC-OP25LV-03-E	3.0		
	JEPMC-OP25LV-10-E	10.0		
Programming Cable for MP2500, MP2500M, MP2500B, and MP2500MB	JEPMC-W2010-03-E	3.0	Serial cable to connect the PC for program development and debugging. 	
	JEPMC-W2010-05-E	5.0		
	JEPMC-W2010-15-E	15.0		
Battery Extension Cable for MP2100 (M), MP2101 (M), and MP2101T (M)	JEPMC-W2090-01-E	1.0	With connectors on both ends 	
T- branch Connector	JEPMC-OP2310-E	—	MPLINK communication connector for 215AIF-01	
MR Connector Converter	JEPMC-OP2320	—	CP-215 communication connector for 215AIF-01	

● Optional Products

Applicable Machine Controller	Product Name	Product Model	Specifications	Qty
MP2000 Series Machine Controllers	Lithium battery 	JZSP-BA01	For data backup, 3.6 V	
MP2200, MP2300	Protective cover 	JEPMC-OP2300	Front cover for empty slot	
	Module mounting fixtures 	JEPMC-OP300	Used to mount a module on DIN rail (1 pair in a set)	
MP2200 (CPU-02), MP2500, MP2500M, MP2500B, MP2500MB	CompactFlash for data storage 	CFI-256MDG	Type I , 256 Mbytes	
MP2100 (M), MP2101 (M), MP2101T (M), MP2500, MP2500M, MP2500B, MP2500MB	CompactFlash adapter (PCMCIA) 	CFC-ADP03	CompactFlash adapter for PCMCIA connectors	
	Screen protection sheets 	CA3-DFS15-01	For integrated 15-inch touch panel	
		CA7-DFS12-01	For integrated 12-inch touch panel	
	Replaceable backlights 	CA7-BLU15-01	For integrated 15-inch touch panel	
		CA3-BLU12-01	For integrated 12-inch touch panel	
	Gaskets 	CA7-WPG15-01	For integrated 15-inch touch panel	
		CA7-WPG12-01	For integrated 12-inch touch panel	
	Brackets 	CA3-ATFALL-01	Brackets used for installing the MP2500/MP2500M controllers (2 sets of 4/set)	
Battery kit 	JEPMC-OP2500	A kit containing a lithium battery, cable (1 m), and clip (Mounting screws are not included.)		
MP2300S, MP2400	Unit base 	JEPMC-OP2300S-E JEPMC-OP2400-E	Attachment for installing the machine controller	

Quick Reference-1

List of Optional Modules

●: Available, ×: Not available, ▲: Available only with devices used for expansion, ※: Version number of the software for the CPU in the machine controller

Classification	Model Name	Specifications	MP2100 (M), MP2101 (M), MP2101T (M)	MP2200	MP2300, MP2310, MP2300S	MP2500 (M) (B)	
Optional Modules	CPU Modules	CPU-01	CPU	×	●	×	×
		CPU-02	USB+CFIF	×	●	×	×
		CPU-03	Ethernet+CFIF	×	●	×	×
		CPU-04	CPU+Ethernet	×	●	×	×
		MPU-01	CPU+SVC-01	▲ ※ Version 2.73 or later	● ※ Version 2.73 or later	● ※ Version 2.73 or later (Cannot be used with MP2300.)	▲ ※ Version 2.73 or later
	Expansion Module	EXIOIF	Expansion	▲	●	×	▲
		MP2100MEX	Expansion I/F board for MP2100M, MP2101M, MP2101TM and MP2500M	●	×	×	●
	Communication Modules	217IF-01	Serial communication	▲	●	●	▲
		218IF-01	Ethernet communication	▲	●	●	▲
		218IF-02	Ethernet communication	▲ ※ Version 2.60 or later	● ※ Version 2.60 or later	● ※ Version 2.60 or later	▲ ※ Version 2.60 or later
		260IF-01	DeviceNet communication	▲	●	●	▲
		261IF-01	PROFIBUS communication	▲	●	●	▲
		262IF-01	FL-net	▲ ※ Version 2.63 or later	● ※ Version 2.63 or later	● ※ Version 2.63 or later	▲ ※ Version 2.63 or later
		263IF-01	EtherNet / IP	▲ ※ Version 2.64 or later	● ※ Version 2.64 or later	● ※ Version 2.64 or later	▲ ※ Version 2.64 or later
		264IF-01	EtherCAT	▲ ※ Version 2.73 or later	● ※ Version 2.73 or later	● ※ Version 2.73 or later	▲ ※ Version 2.73 or later
		265IF-01	CompoNet	▲ ※ Version 2.74 or later	● ※ Version 2.74 or later	● ※ Version 2.74 or later	▲ ※ Version 2.74 or later
		266IF-01*	PROFINET Master	▲ ※ Version 2.81 or later	● ※ Version 2.81 or later	● ※ Version 2.81 or later	● ※ Version 2.81 or later
		266IF-02	PROFINET Slave	▲ ※ Version 2.82 or later	● ※ Version 2.82 or later	● ※ Version 2.82 or later	● ※ Version 2.82 or later
		215AIF-01	CP-215 communication	▲ ※ Version 2.41 or later	● ※ Version 2.41 or later	● ※ Version 2.41 or later	▲ ※ Version 2.41 or later
			MPLINK	▲ ※ Version 2.41 or later	● ※ Version 2.41 or later	● ※ Version 2.41 or later	▲ ※ Version 2.41 or later
	Motion Modules	SVB-01	MECHATROLINK-II	▲ ※ Version 2.02 or later	● ※ Version 2.02 or later	● ※ Version 2.02 or later	▲ ※ Version 2.02 or later
		SVC-01	MECHATROLINK-III	▲ ※ Version 2.70 or later	● ※ Version 2.70 or later	● ※ Version 2.70 or later	▲ ※ Version 2.70 or later
		SVA-01	Analog output	▲ ※ Version 2.20 or later	● ※ Version 2.20 or later	● ※ Version 2.20 or later	▲ ※ Version 2.20 or later
		PO-01	Pulse output	▲ ※ Version 2.44 or later	● ※ Version 2.44 or later	● ※ Version 2.44 or later	▲ ※ Version 2.44 or later
	I/O Modules	LIO-01	16-point input, 16-point output (sink mode output), pulse input: 1 channel	▲	●	●	▲
		LIO-02	16-point input, 16-point output (source mode output), pulse input: 1 channel	▲	●	●	▲
		LIO-04	32-point input/32-point output (sink mode output)	▲ ※ Version 2.20 or later	● ※ Version 2.20 or later	● ※ Version 2.20 or later	▲ ※ Version 2.20 or later
		LIO-05	32-point input/32-point output (source mode output)	▲ ※ Version 2.32 or later	● ※ Version 2.32 or later	● ※ Version 2.32 or later	▲ ※ Version 2.32 or later
		LIO-06	Digital input: 8 points, digital output: 8 points (sink), analog input: 1 channel, analog output: 1 channel, pulse counter: 1 channel	▲ ※ Version 2.63 or later	● ※ Version 2.63 or later	● ※ Version 2.63 or later	▲ ※ Version 2.63 or later
		DO-01	64-point output (sink mode output)	▲ ※ Version 2.32 or later	● ※ Version 2.32 or later	● ※ Version 2.32 or later	▲ ※ Version 2.32 or later
		AI-01	Analog input	▲ ※ Version 2.40 or later	● ※ Version 2.40 or later	● ※ Version 2.40 or later	▲ ※ Version 2.40 or later
		AO-01	Analog output	▲ ※ Version 2.44 or later	● ※ Version 2.44 or later	● ※ Version 2.44 or later	▲ ※ Version 2.44 or later
		CNTR-01	Counter	▲ ※ Version 2.44 or later	● ※ Version 2.44 or later	● ※ Version 2.44 or later	▲ ※ Version 2.44 or later
AFMP-01		AnyWire DB Master (made by Anywire Corporation)	▲ ※ Version 2.02 or later	● ※ Version 2.02 or later	● ※ Version 2.02 or later	▲ ※ Version 2.02 or later	
AFMP-02-C		CC-Link Slave Interface Board (made by Anywire Corporation)	▲ ※ Version 2.51 or later	● ※ Version 2.51 or later	● ※ Version 2.51 or later	▲ ※ Version 2.51 or later	
AFMP-02-CA		CC-Link Slave Interface with AnyWire DB Master Interface Board (made by Anywire Corporation)	▲ ※ Version 2.51 or later	● ※ Version 2.51 or later	● ※ Version 2.51 or later	▲ ※ Version 2.51 or later	
MPANL00-0		A-net/ A-Link Master Unit Module (made by Algo System Co.,Ltd.)	▲ ※ Version 2.46 or later	● ※ Version 2.46 or later	● ※ Version 2.46 or later	▲ ※ Version 2.46 or later	
MPCUNET-0		Cunet Master Unit Module (made by Algo System Co.,Ltd.)	▲ ※ Version 2.81 or later	● ※ Version 2.81 or later	● ※ Version 2.81 or later	● ※ Version 2.81 or later	

* : Estimates are required before ordering this product. Contact your Yaskawa representative for more information.

●: Available, ×: Not available, ▲: Available only with devices used for expansion, ※: Version number of the software for the CPU in the machine controller

Classification	Model Name	Specifications	MP2100 (M), MP2101 (M), MP2101T (M)	MP2200	MP2300, MP2310, MP2300S	MP2500 (M) (B)	
Distributed I/O Modules	For M-III	MTD2310	64-point input, 64-point output	●※ Version 2.71 or later	●※ Version 2.71 or later	●※ Version 2.71 or later	●※ Version 2.71 or later
		MTA2900	Analog input: 8 channels	●※ Version 2.71 or later	●※ Version 2.71 or later	●※ Version 2.71 or later	●※ Version 2.71 or later
		MTA2910	Analog output: 4 channels	●※ Version 2.71 or later	●※ Version 2.71 or later	●※ Version 2.71 or later	●※ Version 2.71 or later
		MTP2900	Pulse input: 2 channels	●※ Version 2.71 or later	●※ Version 2.71 or later	●※ Version 2.71 or later	●※ Version 2.71 or later
		MTP2910	Pulse output: 4 channels	●※ Version 2.71 or later	●※ Version 2.71 or later	●※ Version 2.71 or later	●※ Version 2.71 or later
	For M-II	IO2310	64-point input, 64-point output	●	●	●	●
		IO2330	64-point input, 64-point output	●	●	●	●
		PL2900	Counter	●	●	●	●
		PL2910	Pulse output	●	●	●	●
		AN2900	Analog input	●	●	●	●
		AN2910	Analog output	●	●	●	●
		IO2900	16-point input module	●	●	●	●
		IO2910	16-point output module	●	●	●	●
		IO2920	8-point I/O module	●	●	●	●
		IO2950	Relay output module	●	●	●	●
	AB023-M1	Bit-type distributed I/O terminal (made by Anywire Corporation)	●	●	●	●	
	For M-I	120AVI02030	Analog input, 4 channels	●	●	●	●
		120AVO01030	Analog output, 2 channels	●	●	●	●
		120EHC21140	Reversible counter, 2 channels	●	●	●	●
120MMB20230		Pulse output, 2 channels	●	●	●	●	
Others	For M-II	REP2000	MECHATROLINK-II repeater	●	●	●	●
		MYVIS YV250/YV260	Image-processing unit	●	●	●	●

Note: M-I stands for MECHATROLINK-I, M-II for MECHATROLINK-II, and M-III for MECHATROLINK-III.

Quick Reference-2

Combination of Machine Controllers and JUNMA Series

●: Available

Machine Controllers	MP2100 (M), MP2101 (M), MP2101T (M) Board				●
	MP2200 MP2300 MP2310	SVA-01 Module			
		SVB-01 Module			●
		PO-01 Module	●		
	MP2300/MP2310/MP2300S Basic Module, MP2400				●
MP2500 (B), MP2500M (B)				●	
SERVOPACK Model					SIDE-□□□AP
Servomotor : Rated Output					SIDE-□□□AN
Servomotor Model					
Servomotor Series					
Small-capacity	SJME 	SJME-01AM	100 W	●	●
		SJME-02AM	200 W	●	●
		SJME-04AM	400 W	●	●
		SJME-08AM	750 W	●	●

Quick Reference-3







Combination of Machine Controllers and Σ -III Series

●: Available

Machine Controllers	MP2100 (M), MP2101 (M), MP2101T (M) Board				●
	MP2200 MP2300 MP2310	SVA-01 Module		●	●
		SVB-01 Module			●
		PO-01 Module	●	●	
	MP2300/MP2310/MP2300S Basic Module, MP2400				●
MP2500 (B), MP2500M (B)				●	
SERVOPACK Model					SGDS-□□□01
Servomotor : Rated Output					SGDS-□□□02
Servomotor Model					SGDS-□□□12
Servomotor Series					
Small-capacity	Super High Power Rate Series SGMMJ 	SGMMJ-A1B	10 W	●	●
		SGMMJ-A2B	20 W	●	●
		SGMMJ-A3B	30 W	●	●

Combination of Machine Controllers and Σ -V Series

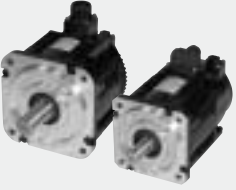



● : Available

Machine Controllers		MP2100 (M), MP2101 (M), MP2101T (M) Board						
		MP2200	SVA-01 Module	●	●			
		MP2300	SVB-01 Module			●	●	
		MP2310	PO-01 Module	●	●			
		MP2300/MP2310/MP2300S Basic Module, MP2400				●	●	
		MP2500 (B), MP2500M (B)				●	●	
SERVOPACK Model					SGDV-□□□□01	SGDV-□□□□05	SGDV-□□□□11	SGDV-□□□□15
Servomotor : Rated Output								
Servomotor Model								
Servomotor Series								
Ultra-Small Capacity	SGMMV 	SGMMV-B3E□	3.3 W	●		●		
		SGMMV-B5E□	5.5 W			●		
		SGMMV-B9E□	11 W	●		●		
		SGMMV-A1□□	10 W	●		●		
		SGMMV-A2□□	20 W	●		●		
		SGMMV-A3□□	30 W	●		●		
Small capacity	SGMJV 	SGMJV-A5A	50 W	●		●		
		SGMJV-01A	100 W	●		●		
		SGMJV-C2A	150 W	●		●		
		SGMJV-02A	200 W	●		●		
		SGMJV-04A	400 W	●		●		
		SGMJV-06A	600 W	●		●		
	SGMAV 	SGMAV-A5A	50 W	●		●		
		SGMAV-01A	100 W	●		●		
		SGMAV-C2A	150 W	●		●		
		SGMAV-02A	200 W	●		●		
		SGMAV-04A	400 W	●		●		
		SGMAV-06A	550 W	●		●		
	SGMPS 	SGMPS-01A	100 W	●		●		
		SGMPS-02A	200 W	●		●		
		SGMPS-04A	400 W	●		●		
		SGMPS-08A	750 W	●		●		
		SGMPS-15A	1.5 kW	●		●		
	Medium capacity	SGMSV 	SGMSV-10□	1.0 kW	●		●	
SGMSV-15□			1.5 kW	●		●		
SGMSV-20□			2.0 kW	●		●		
SGMSV-25□			2.5 kW	●		●		
SGMSV-30□			3.0 kW	●		●		
SGMSV-40□			4.0 kW	●		●		
SGMSV-50□			5.0 kW	●		●		
SGMGV 		SGMGV-03□	0.3 kW	●		●		
		SGMGV-05□	0.45 kW	●		●		
		SGMGV-09□	0.85 kW	●		●		
		SGMGV-13□	1.3 kW	●		●		
		SGMGV-20□	1.8 kW	●		●		
		SGMGV-30□	2.9 kW	●		●		
		SGMGV-44□	4.4 kW	●		●		
Large Capacity	SGMVV 	SGMVV-2BD□	22 kW	●		●		
		SGMVV-3ZD	30 kW	●		●		
		SGMVV-3GD□	37 kW	●		●		
		SGMVV-4ED□	45 kW	●		●		
		SGMVV-5ED□	55 kW	●		●		

Quick Reference-5

Combination of Machine Controllers and Direct Drives / Linear Drives

● : Available

Machine Controllers		MP2100 (M), MP2101 (M), MP2101T (M) Board		●	●			
		MP2200	SVA-01 Module	●	●			
		MP2300	SVB-01 Module	●	●			
		MP2310	PO-01 Module	●	●			
		MP2300/MP2310/MP2300S Basic Module, MP2400		●	●			
		MP2500 (B), MP2500M (B)		●	●			
SERVOPACK Model				SGDV-□□□□01	SGDV-□□□□05			
Direct-drive : Rated Torque, Linear : Peak Force				SGDV-□□□□11	SGDV-□□□□15			
Servomotor Model								
Servomotor Series								
Direct-drive Σ Series	Small-capacity Series SGMCS		SGMCS-02B	2.0 N·m	●	●		
			SGMCS-05B	5.0 N·m	●	●		
			SGMCS-07B	7.0 N·m	●	●		
			SGMCS-04C	4.0 N·m	●	●		
			SGMCS-10C	10.0 N·m	●	●		
			SGMCS-14C	14.0 N·m	●	●		
			SGMCS-08D	8.0 N·m	●	●		
			SGMCS-17D	17.0 N·m	●	●		
			SGMCS-25D	25.0 N·m	●	●		
			SGMCS-16E	16.0 N·m	●	●		
	SGMCS-35E	35.0 N·m	●	●				
	Medium-capacity Series SGMCS		SGMCS-45M	45.0 N·m	●	●		
			SGMCS-80M	80 N·m	●	●		
			SGMCS-1AM	110 N·m	●	●		
			SGMCS-80N	80 N·m	●	●		
			SGMCS-1EN	150 N·m	●	●		
			SGMCS-2ZN	200 N·m	●	●		
			SGLGW Coreless GW		SGLGW-30A050	40 N	●	●
					SGLGW-30A080	80 N	●	●
SGLGW-40A140					140 N	●	●	
SGLGW-40A253	280 N	●			●			
SGLGW-40A365	420 N	●			●			
SGLGW-60A140	220 N	●			●			
SGLGW-60A253	440 N	●			●			
SGLGW-60A365	660 N	●			●			
SGLGW-90A200	1300 N	●			●			
SGLGW-90A370	2200 N	●			●			
SGLGW-90A535	3000 N	●	●					
SGLFW Iron-core FW		SGLFW-20A090	86 N	●	●			
		SGLFW-20A120	125 N	●	●			
		SGLFW-35□120	220 N	●	●			
		SGLFW-35□230	440 N	●	●			
		SGLFW-50□200	600 N	●	●			
		SGLFW-50□380	1200 N	●	●			
		SGLFW-1Z□200	1200 N	●	●			
		SGLFW-1Z□380	2400 N	●	●			
		SGLTW Iron-core TW		SGLTW-20A170A	380 N	●	●	
SGLTW-20A320A	760 N			●	●			
SGLTW-20A460A	1140 N			●	●			
SGLTW-35A170A	660 N			●	●			
SGLTW-35A320A	1320 N			●	●			
SGLTW-35A460A	2000 N			●	●			
SGLTW-35□170H	600 N			●	●			
SGLTW-35□320H	1200 N			●	●			
SGLTW-40□400B	2600 N			●	●			
SGLTW-40□600B	4000 N			●	●			
SGLTW-50□170H	900 N			●	●			
SGLTW-50□320H	1800 N			●	●			
SGLTW-80□400B	5000 N			●	●			
SGLTW-80D600B	7500 N	●	●					

Combination of Machine Controllers and Σ -Stick / Σ -Trac

● : Available

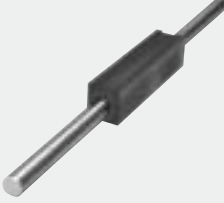
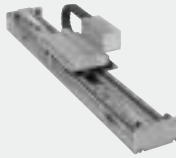
Machine Controllers	MP2100 (M), MP2101 (M), MP2101T (M) Board				●	●
	MP2200	SVA-01 Module	●	●		
	MP2300	SVB-01 Module			●	●
	MP2310	PO-01 Module	●	●		
	MP2300/MP2310/MP2300S Basic Module, MP2400				●	●
MP2500 (B), MP2500M (B)				●	●	
SERVOPACK Model						
Servomotor : Rated Output Direct-drive : Rated Torque, Linear : Peak Force						
Servomotor Model						
Servomotor Series						
Cylindrical Type		SGLC-D16A085	60 N		●	●
		SGLC-D16A115	90 N		●	●
		SGLC-D16A145	120 N		●	●
		SGLC-D20A100	150 N		●	●
		SGLC-D20A135	225 N		●	●
		SGLC-D20A170	300 N		●	●
		SGLC-D25A125	280 N		●	●
		SGLC-D25A170	420 N		●	●
		SGLC-D25A215	560 N		●	●
		SGLC-D32A165	420 N		●	●
		SGLC-D32A225	630 N		●	●
		SGLC-D35A285	840 N		●	●
		Linear Slider		SGT□F3 □-□□□	220 N	
SGT□F4 □-□□□	440 N				●	●
SGT□F9 □-□□□	600 N				●	●
SGT□FA □-□□□	1200 N				●	●
SGT□GD□-□□□	140 N				●	●
SGT□GE □-□□□	280 N				●	●
SGT□GF □-□□□	420 N				●	●
SGT□GG□-□□□	220 N				●	●
SGT□GH□-□□□	440 N				●	●
SGT□GI □-□□□	660 N				●	●

Third-party Trademarks in this Catalog

- Adobe Reader is a registered trademark of Adobe Systems Incorporated.
- AnyWire is a registered trademark of the Anywire Corporation.
- Celeron and Pentium is a registered trademark of the Intel Corporation.
- Compact Flash is a registered trademark of the SanDisk Corporation, and the CompactFlash and CF logos and trademarks are licensed at no charge and royalty-free to CompactFlash Association (CFA) members.
- Eden is a registered trademark of VIA Technologies, Inc.
- Ethernet is a registered trademark of the Xerox Corporation.
- Geode is a registered trademark of Advanced Micro Devices, Inc.
- MagicConnect is a registered trademark of the NTT IT Corporation.
- UNI-WIRE is a registered trademark of Kuroda Precision Industries Ltd.
- Windows 7, Windows 2000, Windows XP, Windows XP Embedded, Windows 98SE, Windows ME, Windows CE, Windows Vista, Access, Excel, Visual Basic, Visual C, Visual C++, and Internet Explorer are trademarks or registered trademarks of the Microsoft Corporation.

This catalog may contain other proprietary names and copyright notices.
Trademark symbols (TM and ®) do not appear with product or company names in this catalog.

(1) Details of Warranty

■ Warranty Period

The warranty period for a product that was purchased (hereafter called "delivered product") is one year from the time of delivery to the location specified by the customer or 18 months from the time of shipment from the Yaskawa factory, whichever is sooner.

■ Warranty Scope

Yaskawa shall replace or repair a defective product free of charge if a defect attributable to Yaskawa occurs during the warranty period above. This warranty does not cover defects caused by the delivered product reaching the end of its service life and replacement of parts that require replacement or that have a limited service life.

This warranty does not cover failures that result from any of the following causes.

1. Improper handling, abuse, or use in unsuitable conditions or in environments not described in product catalogs or manuals, or in any separately agreed-upon specifications
2. Causes not attributable to the delivered product itself
3. Modifications or repairs not performed by Yaskawa
4. Abuse of the delivered product in a manner in which it was not originally intended
5. Causes that were not foreseeable with the scientific and technological understanding at the time of shipment from Yaskawa
6. Events for which Yaskawa is not responsible, such as natural or human-made disasters

(2) Limitations of Liability

1. Yaskawa shall in no event be responsible for any damage or loss of opportunity to the customer that arises due to failure of the delivered product.
2. Yaskawa shall not be responsible for any programs (including parameter settings) or the results of program execution of the programs provided by the user or by a third party for use with programmable Yaskawa products.
3. The information described in product catalogs or manuals is provided for the purpose of the customer purchasing the appropriate product for the intended application. The use thereof does not guarantee that there are no infringements of intellectual property rights or other proprietary rights of Yaskawa or third parties, nor does it construe a license.
4. Yaskawa shall not be responsible for any damage arising from infringements of intellectual property rights or other proprietary rights of third parties as a result of using the information described in catalogs or manuals.

(3) Suitability for Use

1. It is the customer's responsibility to confirm conformity with any standards, codes, or regulations that apply if the Yaskawa product is used in combination with any other products.
2. The customer must confirm that the Yaskawa product is suitable for the systems, machines, and equipment used by the customer.
3. Consult with Yaskawa to determine whether use in the following applications is acceptable. If use in the application is acceptable, use the product with extra allowance in ratings and specifications, and provide safety measures to minimize hazards in the event of failure.
 - Outdoor use, use involving potential chemical contamination or electrical interference, or use in conditions or environments not described in product catalogs or manuals
 - Nuclear energy control systems, combustion systems, railroad systems, aviation systems, vehicle systems, medical equipment, amusement machines, and installations subject to separate industry or government regulations
 - Systems, machines, and equipment that may present a risk to life or property
 - Systems that require a high degree of reliability, such as systems that supply gas, water, or electricity, or systems that operate continuously 24 hours a day
 - Other systems that require a similar high degree of safety
4. Never use the product for an application involving serious risk to life or property without first ensuring that the system is designed to secure the required level of safety with risk warnings and redundancy, and that the Yaskawa product is properly rated and installed.
5. The circuit examples and other application examples described in product catalogs and manuals are for reference. Check the functionality and safety of the actual devices and equipment to be used before using the product.
6. Read and understand all use prohibitions and precautions, and operate the Yaskawa product correctly to prevent accidental harm to third parties.

(4) Specifications Change

The names, specifications, appearance, and accessories of products in product catalogs and manuals may be changed at any time based on improvements and other reasons. The next editions of the revised catalogs or manuals will be published with updated code numbers. Consult with your Yaskawa representative to confirm the actual specifications before purchasing a product.

● e-Mecha Site

To see details on Yaskawa's controllers, click **Controllers** on Yaskawa's Products and Technical Information website, usually referred to as the e-Mecha site. Here, you can find and download catalogs, and other information about the MP2000 Series.

Note: Some information is restricted to members only.



Yaskawa's e-Mecha Site



Download Catalogs



Product Features

MP2000 SERIES

IRUMA BUSINESS CENTER (SOLUTION CENTER)

480, Kamifujisawa, Iruma, Saitama, 358-8555, Japan
Phone 81-4-2962-5151 Fax 81-4-2962-6138
<http://www.yaskawa.co.jp>

YASKAWA AMERICA, INC.

2121, Norman Drive South, Waukegan, IL 60085, U.S.A.
Phone 1-800-YASKAWA (927-5292) or 1-847-887-7000 Fax 1-847-887-7310
<http://www.yaskawa.com>

YASKAWA ELÉTRICO DO BRASIL LTDA.

777, Avenida Piraporinha, Diadema, São Paulo, 09950-000, Brasil
Phone 55-11-3585-1100 Fax 55-11-3585-1187
<http://www.yaskawa.com.br>

YASKAWA EUROPE GmbH

185, Hauptstraße, Eschborn, 65760, Germany
Phone 49-6196-569-300 Fax 49-6196-569-398
<http://www.yaskawa.eu.com>

YASKAWA ELECTRIC KOREA CORPORATION

9F, Kyobo Securities Bldg., 26-4, Yeouido-dong, Yeongdeungpo-gu, Seoul, 150-737, Korea
Phone 82-2-784-7844 Fax 82-2-784-8495
<http://www.yaskawa.co.kr>

YASKAWA ELECTRIC (SINGAPORE) PTE. LTD.

151, Lorong Chuan, #04-02A, New Tech Park 556741, Singapore
Phone 65-6282-3003 Fax 65-6289-3003
<http://www.yaskawa.com.sg>

YASKAWA ELECTRIC (THAILAND) CO., LTD.

252/125-126, 27th Floor, Muang Thai-Phatra Tower B, Rachadapisek Road, Huaykwang, Bangkok, 10310, Thailand
Phone 66-2693-2200 Fax 66-2693-4200
<http://www.yaskawa.co.th>

YASKAWA ELECTRIC (CHINA) CO., LTD.

22F, One Corporate Avenue, No.222, Hubin Road, Shanghai, 200021, China
Phone 86-21-5385-2200 Fax 86-21-5385-3299
<http://www.yaskawa.com.cn>

YASKAWA ELECTRIC (CHINA) CO., LTD. BEIJING OFFICE

Room 1011, Tower W3 Oriental Plaza, No.1, East Chang An Ave.,
Dong Cheng District, Beijing, 100738, China
Phone 86-10-8518-4086 Fax 86-10-8518-4082

YASKAWA ELECTRIC TAIWAN CORPORATION

9F, 16, Nanking E. Rd., Sec. 3, Taipei, 104, Taiwan
Phone 886-2-2502-5003 Fax 886-2-2505-1280
<http://www.yaskawa-taiwan.com.tw>

YASKAWA**YASKAWA ELECTRIC CORPORATION**

In the event that the end user of this product is to be the military and said product is to be employed in any weapons systems or the manufacture thereof, the export will fall under the relevant regulations as stipulated in the Foreign Exchange and Foreign Trade Regulations. Therefore, be sure to follow all procedures and submit all relevant documentation according to any and all rules, regulations and laws that may apply. Specifications are subject to change without notice for ongoing product modifications and improvements.

© 2004-2015 YASKAWA ELECTRIC CORPORATION.

LITERATURE NO. KAEP C880700 15L <11>-0

Published in Japan June 2015

15-3-13