

Table of Contents

1. Basic Units	5
2. System Configuration Example	6
3. Component Part Numbers.....	7
4. Base Units	9
5. CPU Specifications	11
6. Installation and Usage Conditions.....	14
7. Base Unit Specifications	16
8. Switches	17
9. Display and Indicators.....	18
10. Self-Configuration.....	20
11. MECHATROLINK-III Specifications.....	21
12. MECHATROLINK-III Network Topologies	22
13. MECHATROLINK-III Synchronization between Modules.....	25
14. Devices Connectable via MECHATROLINK-III	26
15. Connecting the RLY OUT Connector.....	27
16. Ethernet Connector Details	28
17. Option Module - AI-01 (Analog Input) Module.....	31
18. Option Module - AO-01 (Analog Output) Module	37
19. Option Module - DO-01 (Digital Output) Module	40
20. Option Module - LIO-01/02 Module	44
21. Option Module - LIO-04/05 Modules	52
22. Option Module - LIO-06 Module	64
23. Option Module – 218IF-Y1	74
24. Terminal Block 60372499 and Cable CBL-MP2A-XXA	76
25. Terminal Block 60372471 and Cable CBL-MP2B-XXA.....	77
26. Terminal Block 60372501 and Cable CBL-MP2C-XXC.....	78
27. Cable Shielding, Segregation and Noise Immunity	79

Copyright © 2014 YASKAWA AMERICA, INC.

All rights reserved. No part of this publication may be reproduced, stored in a retrieval system, or transmitted, in any form, or by any means, mechanical, electronic, photocopying, recording, or otherwise, without the prior written permission of Yaskawa. No patent liability is assumed with respect to the use of the information contained herein. Moreover, because Yaskawa is constantly striving to improve its high-quality products, the information contained in this manual is subject to change without notice. Every precaution has been taken in the preparation of this manual. Nevertheless, Yaskawa assumes no responsibility for errors or omissions. Neither is any liability assumed for damages resulting from the use of the information contained in this publication.



1 Basic Units

“Basic Unit” is a collective term that refers to the modules in the following table.

Unit Name	Primary Function
CPU Module	Stores the module definitions and programs, and interprets the programs. The CPU Module also controls the Optional Modules.
Base Unit	Contains the power supply and provides the backplane to which Modules are mounted.

The Basic Modules are typically connected as shown in the following examples.

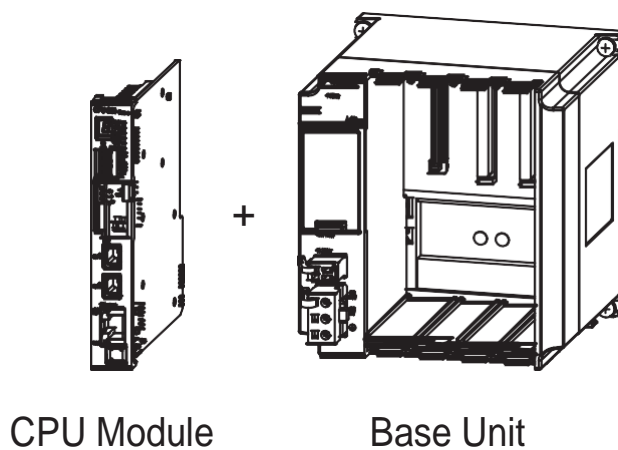

2 System Configuration Example

The following figure shows a typical system configuration.

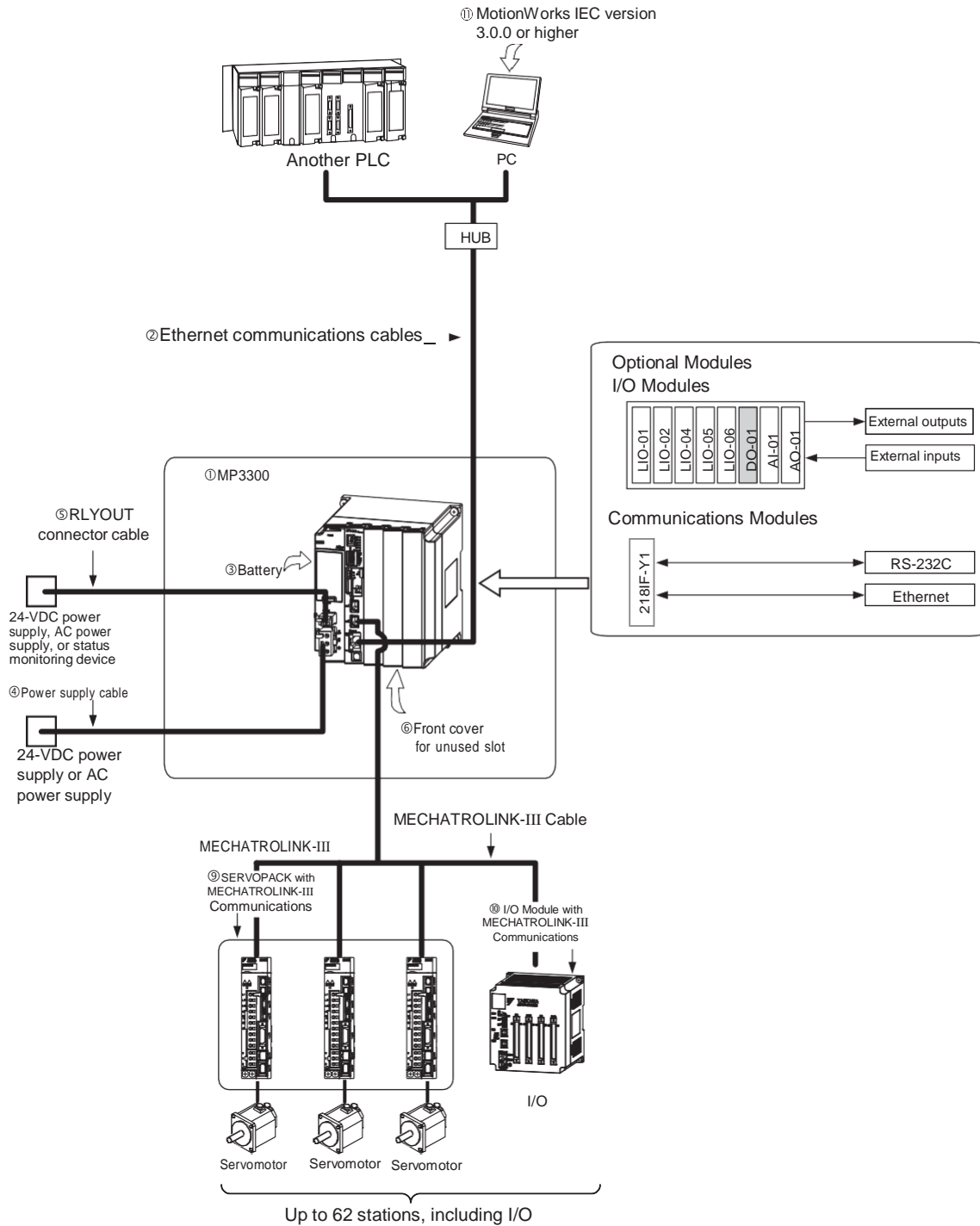

3 Component Part Numbers

System Components		
Type	Part Number	Description
CPU	PMC-U-MP33004	CPU, MP3300, 4 axis, 400 MHz, IMI Connector
	PMC-U-MP33008	CPU, MP3300, 8 axis, 400 MHz, IMI Connector
	PMC-U-MP33020	CPU, MP3300, 20 axis, 400 MHz, IMI Connector
	PMC-U-MP33104	CPU, MP3300, 4 axis, 400 MHz, RJ45 Connector
	PMC-U-MP33108	CPU, MP3300, 8 axis, 400 MHz, RJ45 Connector
	PMC-U-MP33120	CPU, MP3300, 20 axis, 400 MHz, RJ45 Connector
	PMC-U-MP33320	CPU, MP3300, 20 axis, 800 MHz, IMI Connector
	PMC-U-MP33332	CPU, MP3300, 32 axis, 800 MHz, IMI Connector
	PMC-U-MP33420	CPU, MP3300, 20 axis, 800 MHz, RJ45 Connector
	PMC-U-MP33432	CPU, MP3300, 32 axis, 800 MHz, RJ45 Connector
	PMC-U-MP33532	CPU, MP3300, 32 axis, 1.2 GHz, IMI Connector
	PMC-U-MP33562	CPU, MP3300, 62 axis, 1.2 GHz, IMI Connector
	PMC-U-MP33632	CPU, MP3300, 32 axis, 1.2 GHz, RJ45 Connector
	PMC-U-MP33662	CPU, MP3300, 62 axis, 1.2 GHz, RJ45 Connector
Base Unit	JEPMC-BU3304-E	Base Unit with DC Power Supply, 1 Slot, MP3300iec
	JEPMC-BU3303-E	Base Unit with DC Power Supply, 3 Slots, MP3300iec
	JEPMC-BU3302-E	Base Unit with DC Power Supply, 8 Slots, MP3300iec
	JEPMC-BU3301-E	Base Unit with AC Power Supply, 8 Slots, MP3300iec
Option Card	JAPMC-AN2300	Analog Inputs (AI-01)
	JAPMC-AN2310-E	Analog Outputs (AO-01)
	JAPMC-DO2300	Digital Output Module (DO-01)
	JAPMC-IO2300-E	Digital I/O Module (LIO-01)
	JAPMC-IO2301-E	Digital I/O Module (LIO-02)
	JAPMC-IO2303	Digital I/O Module (LIO-04)
	JAPMC-IO2304	Digital I/O Module (LIO-05)
	JAPMC-IO2305-E	Digital Multi-Function I/O Module (LIO-06)
	JAPMC-CM2301-E	Ethernet & RS232C Communication (218IF-Y1)
MECHATROLINK Network	JEPMC-MT2000-E	HUB, MECHATROLINK-III NETWORK, 8 SLAVE PORTS
	JEPMC-MTP2910-E	STEPPER/ PULSE COUNTER MODULE, MECHATROLINK NETWORK
	JEPMC-MTD2310-E	I/O MODULE, MECHATROLINK NETWORK, 64 IN, 64 OUT

3 Component Part Numbers

System Components		
Type	Part Number	Description
MECHATROLINK Cables	JEPMC-W6012-A2-E	0.2m, IMI to IMI (for Sigma-5)
	JEPMC-W6012-A5-E	0.5m, IMI to IMI (for Sigma-5)
	JEPMC-W6012-01-E	1.0m, IMI to IMI (for Sigma-5)
	JEPMC-W6012-02-E	2.0m, IMI to IMI (for Sigma-5)
	JEPMC-W6012-03-E	3.0m, IMI to IMI (for Sigma-5)
	JEPMC-W6012-04-E	4.0m, IMI to IMI (for Sigma-5)
	JEPMC-W6012-05-E	5.0m, IMI to IMI (for Sigma-5)
	JEPMC-W6012-10-E	10.0m, IMI to IMI (for Sigma-5)
	JEPMC-W6012-20-E	20.0m, IMI to IMI (for Sigma-5)
	JEPMC-W6012-30-E	30.0m, IMI to IMI (for Sigma-5)
	JEPMC-W6012-40-E	40.0m, IMI to IMI (for Sigma-5)
	JEPMC-W6012-50-E	50.0m, IMI to IMI (for Sigma-5)
	JZSP-CM3RMM0-00P2-E	0.2m, RJ45 to IMI (for Sigma-7 amp to controller)
	JZSP-CM3RMM0-00P5-E	0.5m, RJ45 to IMI (for Sigma-7 amp to controller)
	JZSP-CM3RMM0-01-E	1.0m, RJ45 to IMI (for Sigma-7 amp to controller)
	JZSP-CM3RMM0-03-E	3.0m, RJ45 to IMI (for Sigma-7 amp to controller)
	JZSP-CM3RMM0-05-E	5.0m, RJ45 to IMI (for Sigma-7 amp to controller)
	JZSP-CM3RMM0-10-E	10.0m, RJ45 to IMI (for Sigma-7 amp to controller)
	JZSP-CM3RM00-20-E	20.0m, RJ45 to IMI (for Sigma-7 amp to controller)
	JZSP-CM3RM00-30-E	30.0m, RJ45 to IMI (for Sigma-7 amp to controller)
	JZSP-CM3RM01-40-E	40.0m, RJ45 to IMI (for Sigma-7 amp to controller)
	JZSP-CM3RM01-50-E	50.0m, RJ45 to IMI (for Sigma-7 amp to controller)
	JZSP-CM3RRM0-00P2-E	0.2m, RJ45 to RJ45 (for Sigma-7 amp to amp)
	JZSP-CM3RRM0-00P5-E	0.5m, RJ45 to RJ45 (for Sigma-7 amp to amp)
	JZSP-CM3RRM0-01-E	1.0m, RJ45 to RJ45 (for Sigma-7 amp to amp)
	JZSP-CM3RRM0-03-E	3.0m, RJ45 to RJ45 (for Sigma-7 amp to amp)
	JZSP-CM3RRM0-05-E	5.0m, RJ45 to RJ45 (for Sigma-7 amp to amp)
	JZSP-CM3RRM0-10-E	10.0m, RJ45 to RJ45 (for Sigma-7 amp to amp)
	JZSP-CM3RR00-20-E	20.0m, RJ45 to RJ45 (for Sigma-7 amp to amp)
	JZSP-CM3RR00-30-E	30.0m, RJ45 to RJ45 (for Sigma-7 amp to amp)
	JZSP-CM3RR01-40-E	40.0m, RJ45 to RJ45 (for Sigma-7 amp to amp)
	JZSP-CM3RR01-50-E	50.0m, RJ45 to RJ45 (for Sigma-7 amp to amp)
	Accessories	JEPMC-OP3005
JEPMC-OP2300		Option Slot Cover
JEPMC-OP3001		Replacement Power Supply Side Cover
JEPMC-OP3002		Replacement Option Base Side Cover

4 Base Units

The Base Unit provides the backplane to which Modules are mounted and supplies the required power to the Modules. There are three models of Base Units, a one-slot model, a three-slot model, and an eight-slot model. This section shows the appearance and part names of the Base Unit and describes the connector.

◆ Part Names

Figure 1 illustrates the appearance of the Base Unit and a part name.

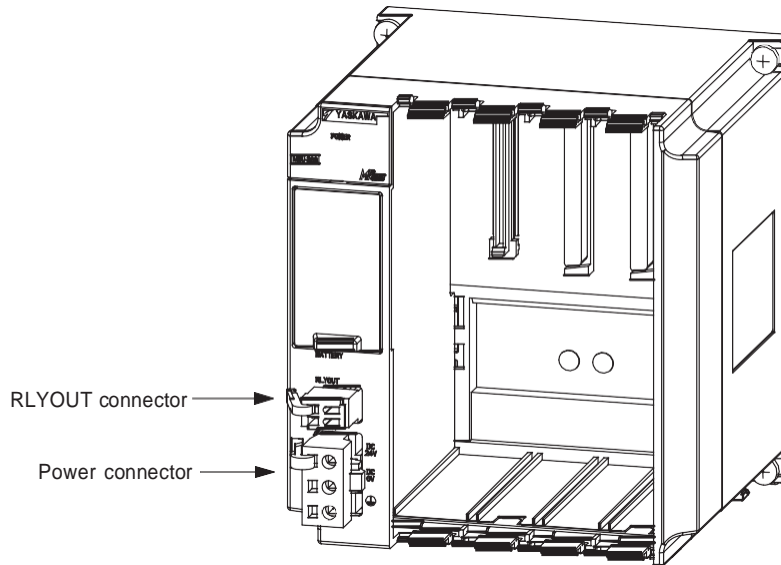

Figure 1 Base Unit

◆ Appearance

● Base Unit

1 Slot

3 Slots

8 Slots

(Common)

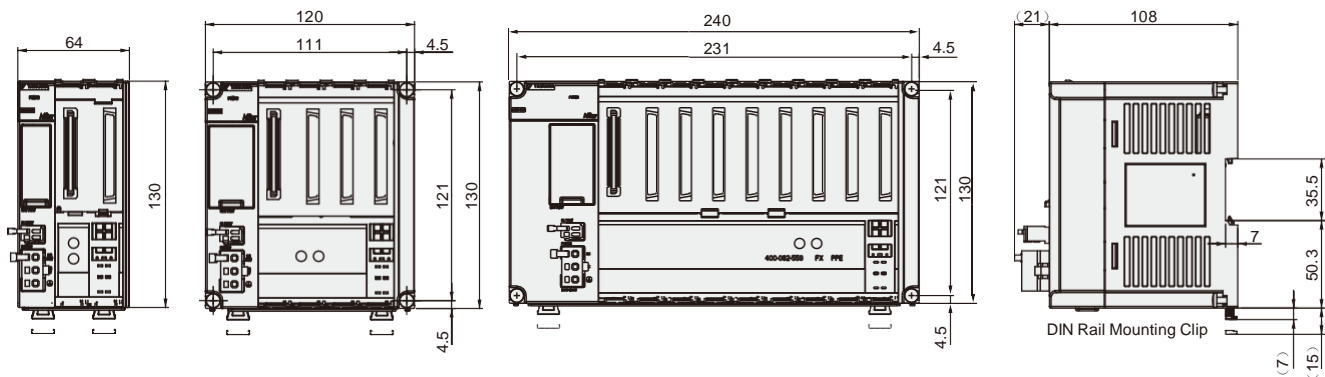

4 Base Units

◆ Connector

The Base Unit has two connectors: an RLYOUT connector and a power connector.

■ RLYOUT Connector

The RLYOUT connector outputs the status of the CPU Module.

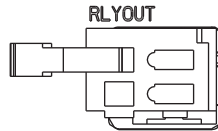

Figure 2 RLYOUT Connector Model: 734-302

Pin Assignments

No.	Signal Label	Description
1	OUT	Normal operation: Circuit closed. Error: Circuit open.
2	OUT	

■ Power Connector

Connect the power supply to this connector.

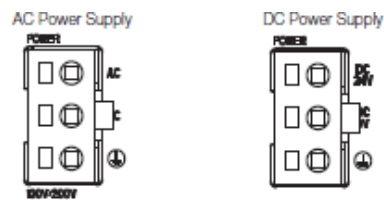

Type	Model	Color
AC power supply	3-2134249-3	Black
DC power supply	4-2013522-3	White

Figure 3 Power Connector

Type	Model	Color
DC power supply	4-2013522-3	White

Pin Assignments

No.	Signal Label	Description
3	24 VDC	Power input wire for 24 VDC
2	0 VDC	Power input wire for 0 VDC
1	FG	Connects to the frame ground. (Ground to 100 W max.)

5 CPU Specifications

The hardware specifications of the CPU Unit are given in the following table.

Item	CPU Specification
Model	PMC-U-MP33xxx-□□□ (Note: □□□ = blank for standard models, RBT for Robot Controller option. RBT option only available on 800MHz and 1.2 GHz models)
Part Number: Description	<ul style="list-style-type: none"> • PMC-U-MP33004: CPU, MP3300, 4 axis, 400 MHz, IMI Connector • PMC-U-MP33008: CPU, MP3300, 8axis, 400 MHz, IMI Connector • PMC-U-MP33020: CPU, MP3300, 20 axis, 400 MHz, IMI Connector • PMC-U-MP33320-□□□: CPU, MP3300, 20 axis, 800 MHz, IMI Connector • PMC-U-MP33332-□□□: CPU, MP3300, 32 axis, 800 MHz, IMI Connector • PMC-U-MP33532-□□□: CPU, MP3300, 32 axis, 1.2 GHz, IMI Connector • PMC-U-MP33562-□□□: CPU, MP3300, 62 axis, 1.2 GHz, IMI Connector • PMC-U-MP33104: CPU, MP3300, 4 axis, 400 MHz, RJ45 Connector • PMC-U-MP33108: CPU, MP3300, 8axis, 400 MHz, RJ45 Connector • PMC-U-MP33120: CPU, MP3300, 20 axis, 400 MHz, RJ45 Connector • PMC-U-MP33420-□□□: CPU, MP3300, 20 axis, 800 MHz, RJ45 Connector • PMC-U-MP33432-□□□: CPU, MP3300, 32 axis, 800 MHz, RJ45 Connector • PMC-U-MP33520: CPU, MP3300, 20 axis, 1.2 GHz, RJ45 Connector • PMC-U-MP33532 CPU, MP3300, 32 axis, 1.2 GHz, RJ45 Connector • PMC-U-MP33562: CPU, MP3300, 62 axis, 1.2 GHz, RJ45 Connector • PMC-U-MP33632-□□□: CPU, MP3300, 32 axis, 1.2 GHz, RJ45 Connector • PMC-U-MP33662-□□□: CPU, MP3300, 62 axis, 1.2 GHz, RJ45 Connector
Flash Memory	Capacity: 40 MB (32 MB of user memory)
SDRAM	Capacity: 256 MB
SRAM	Capacity: 4 MB or 8 MB (battery backup): 1.2GHz models have 8MB SRAM
Calendar	Seconds, minutes, hour, day, week, month, year, day of week, and timing (battery backup)
Ethernet	10Base-T or 100Base-TX
MECHATROLINK	MECHATROLINK-III: 1 circuit with 2 ports
USB	USB 2.0 Type A host, 1 port Compatible devices: USB storage
Indicators and Displays	Seven-segment display Status indicators USB status indicator MECHATROLINK-III status indicators Ethernet status indicators
Switches	DIP switch: Mode switch STOP/SAVE switch. <i>Refer to Switches on page 16</i> for detailed switch information.

◆ CPU Communications Specifications

The specifications of the Communications Protocols built into the CPU Module are given in the following table.

Protocol	Mode	Detail
Modbus TCP	MP3300iec as Master (Client)	Maximum Number of Data Blocks = 20
	MP3300iec as Slave (Server)	1000 registers in, 1000 registers out, 256 coils in, 256 coils out
Ethernet/IP	MP3300iec as Master (Scanner)	Maximum Number of Data Blocks = 100
	MP3300iec as Slave (Adapter)	Total of 16 instances in, 16 instances out, arranged as 3 instances of 256 bytes, 3 instances of 128 bytes, and 10 instances of 496 bytes.
OPC	read/write	Any Global variable can be configured, requires OPC Server running on PC
Custom Protocol	n/a	Use the YDeviceComm firmware library to create a custom communication protocol.
Network Variables	read/write	Variables configured with MotionWorks IEC software that allow automatic data transfer from controller to controller.

5 CPU Specifications

◆ CPU Module Appearance and Component Names

Figure 4 shows the appearance of the CPU Modules and the component names.

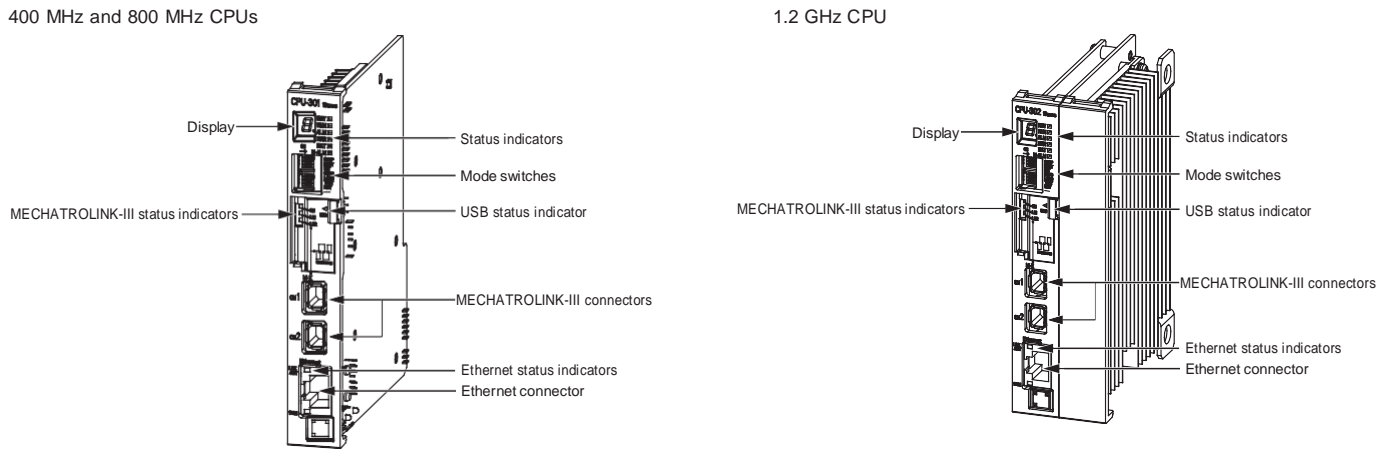

Figure 4 CPU Modules and Component Names

◆ CPU Module Connectors

The CPU Module has three types of connectors: MECHATROLINK-III, Ethernet, and USB.

■ MECHATROLINK-III Connectors

Figure 5 illustrates connectors used to connect MECHATROLINK-III communications devices. CPU options with MECHATROLINK-III RJ45 connectors (not shown) are also available

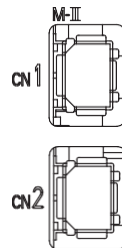

Figure 5 MECHATROLINK-III IMI Connectors.

*There are CPU options with MECHATROLINK-III RJ45 Connectors (not shown)

■ Ethernet Connectors

Figure 6 illustrates the connector used to connect Ethernet communications devices.

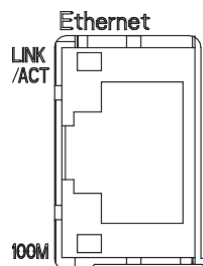

Figure 6 Ethernet Connector

■ USB Connector

Figure 5 illustrates the connector used to connect a USB memory device.

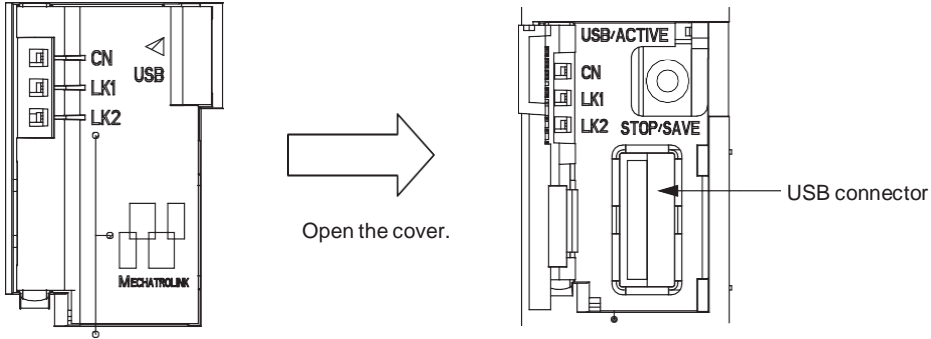

Figure 7 USB Connector

NOTICE: Equipment Hazard. Before removing the USB memory device, press the STOP/SAVE switch and wait until the USB status indicator goes out. If the USB memory device is removed while the USB status indicator is lit or flashing, the data may become corrupted.

6 Installation and Usage Conditions

This section describes installation and usage conditions for the MP3300iec Series Machine Controllers.

Install the MP3300iec Series Controllers in an environment with the following conditions.

◆ Installation and Usage Conditions

Table 1 MP3300iec Installation and Usage Conditions

Item		Specification
Environmental Conditions	Ambient Operating Temperature	0 to 60°C - Forced cooling is required if 55°C is exceeded (50°C for 800MHz model)
	Ambient Storage Temperature	-25 to 85°C
	Ambient Operating Humidity	10% to 95% RH (with no condensation)
	Ambient Storage Humidity	10% to 95% RH (with no condensation)
	Pollution Level	Conforms to JIS B 3502 Pollution Degree 2.
	Corrosive Gas	There must be no combustible or corrosive gas.
	Operating Altitude	2,000 m max.
Mechanical Operating Conditions	Vibration Resistance	Conforms to JIS B 3502. Continuous vibration: 5 to 9 Hz with single-amplitude of 1.75 mm 9 to 150 Hz with fixed acceleration of 4.9 m/s ² Intermittent vibration: 5 to 9 Hz with single-amplitude of 3.5 mm 9 to 150 Hz with fixed acceleration of 9.8 m/s ² 10 sweeps each in X, Y, and Z directions for both intermittent and continuous vibration
	Shock Resistance	Size of shock: Peak acceleration of 147 m/s ² (15 G) Duration: 11 ms 3 times each in X, Y, and Z directions
Electrical Operating Conditions	Noise Resistance	Conforms to EN 61000-6-2, EN 61000-6-4, and EN 55011 (Group 1 Class A). Power supply noise (FT noise): ±2 kV min. for one minute Radiation noise (FT noise): ±1 kV min. for one minute Ground noise (impulse noise): ±1 kV min. for 10 minutes Electrostatic noise (contact discharge method): ±6 kV or more, 10 times
Installation Conditions	Ground	Ground to 100 Ω max.
	Cooling Method	Natural cooling or forced-air cooling. <i>Refer to Control Panel Cooling Method on page 14</i>

◆ Control Panel Cooling Method

The components that are used in the Machine Controller require the ambient operating temperature to be between 0 and 60 °C. Use one of the methods described below to ensure adequate cooling in the control panel.

NOTICE: *Equipment Damage. Use forced-air cooling if the ambient temperature exceeds 55°C.*

■ Control Panels with Natural Cooling

- Do not mount the Machine Controller at the top of the control panel, where the hot air that is generated inside the panel collects.
- Leave sufficient space above and below the Machine Controller, and maintain adequate distances from other devices, cable ducts, and other objects to ensure suitable air circulation.
- Do not mount the Machine Controller in any direction other than the specified direction.
- Do not mount the Machine Controller on top of any device that generates a significant amount of heat.
- Do not subject the Machine Controller to direct sunlight.

■ Control Panels with Forced-air Cooling

Install a fan near the center of and at the top or bottom of the Machine Controller for either of the following methods.

- Forced draft method (A fan or a similar device is used to circulate the air in the interior and the exterior of the panel.).
- Forced circulation method (A fan or a similar device is mounted to the airtight panel to circulate the air inside.).

Note: 1. Use the following guideline when selecting the fan:

- 80 x 80 mm min., Maximum air flow: 0.9 m³/min, Maximum static pressure: 26.5 Pa or higher.
- 2. Adjust the fan installation location and the direction of air flow as shown in [Figure 8](#).

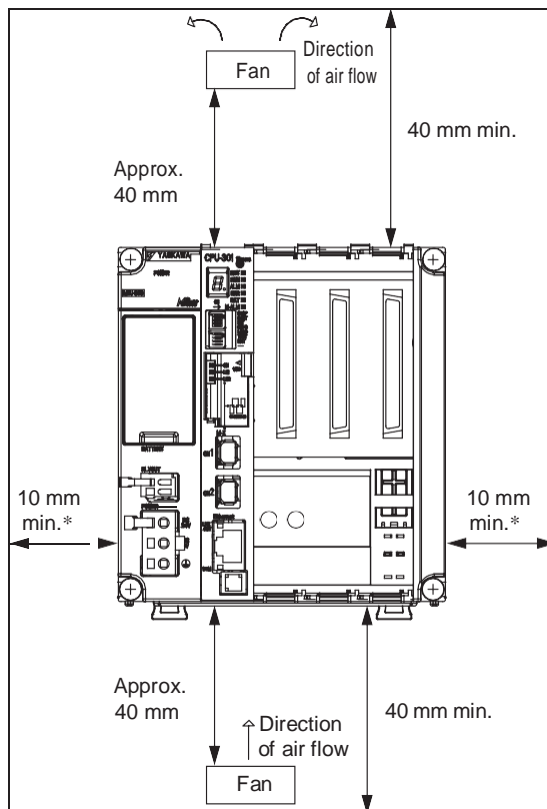

* For a control panel with natural cooling with the MBU-303 Base Unit: 30 mm min.

Figure 8 Fan installation location and air flow direction

7 Base Unit Specifications

The specifications of the Base Units are listed in [Table 2](#).

Table 2 Base Unit Specifications

Item		Specification			
		1 slot	3 slots	8 slots DC	8 slots AC
Model		JEPMC-BU3304-E	JEPMC-BU3303-E	JEPMC-BU3302-E	JEPMC-BU3301-E
Abbreviation		MBU-304	MBU-303	MBU-302	MBU-301
Number of Slots		1	3	8	
Mountable Modules		MP2000-series Optional Modules			
Power Supply Section	Input Voltage	24 VDC			110/220 VAC
	Allowable Input Voltage Range	19.2 to 28.8 VDC			85 to 132 VAC/ 198 to 276 VAC
	Input Current	1.0 A max. (at rated input/output)	1.5 A max. (at rated input/output)		3.0 A max. (at rated input/output)
	Inrush Current	40 A, 10 ms max.		30 A, 10 ms max.	40 A, 10 ms max.
	Allowable Power Loss Time	1 ms			20 ms
	Rated Voltage	5.15 V		5.0 V	
	Rated Current	2.5 A	4.5 A	4.0 A	8.0 A
	Output Current Range	0 to 2.5 A	0 to 4.5 A	0.0 to 4.0 A	0.0 to 8.0 A
	Rated Voltage Accuracy	5.15 V \pm 2% max. (5.05 to 5.25 V)			
Battery	You can mount a memory backup Battery for retained variables, absolute encoder offsets, and alarm history.				
RLY OUT		<p>A normally open relay output that is linked to the CPU Module status Normal operation: Circuit closed. Error: Circuit open.</p> <p>Contact Ratings:</p> <ul style="list-style-type: none"> • 125 Vac, 0.4 A resistive load, 0.20 A inductive load • 24 Vdc, 0.5 A resistive load, 0.25 A inductive load 			
Indicators		POWER			
Connectors		POWER: Power supply connector RLY OUT: Relay contact connector			

8 Switches

The CPU Module has the following two types of switches.

- DIP switches: Mode switches
- STOP/SAVE switch

◆ DIP Switches: Mode Switches

The SW1 and SW2 switches are checked at start-up, and their behavior is described in the following tables:

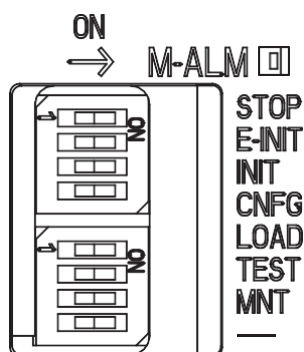

Table 3 SW1 Switches

SW	Description
STOP	When ON, prevents PLC from running.
E-INIT	When ON, overrides Ethernet configuration according to Table 5 .
INIT	When ON, bypass the saved configuration and initialize the SRAM and clock settings.
CNFG	When ON, the controller creates Axes and I/O for all connected devices. (Auto-configuration)

Table 4 SW2 Switches

SW	Description
LOAD	This switch is not used
TEST	When ON, the IP address is scrolled across the seven segment display.
MNT	When ON, controller starts up in supervisor mode. In this mode MECHATROLINK III, PLC, Modbus/TCP and Ethernet/IP do not start. The controller firmware can be updated, and clearing DOS FS alarms will repair the DOS FS.
-- / DHCP	DHCP Selection when E-INIT is ON.

E-INIT and - switches can override the Ethernet configuration according to [Table 5](#).

Table 5 Operation of E-INIT, E-PM0 and E-PM1 for Configuring Ethernet

	E-INIT	-- / DHCP
Static Configuration	OFF	N/A
192.168.1.1	ON	OFF
DHCP	ON	ON

9 Display and Indicators

The CPU Module has the following display and four types of indicators.

- Display
- Status indicators
- USB status indicator
- MECHATROLINK-III status indicators
- Ethernet status indicators

◆ Display

The following situations use the seven segment display:

- Manufacturing: During programming the seven segment display outputs “FLASH...”. When finished, the seven segment display outputs “donE”.
- Startup: If the controller cannot boot because of a bad firmware image check sum, the seven segment display outputs “bOOt ERROR”
- IP Address: If the TEST switch is ON, then the seven segment display outputs the IP address.
- Firmware update: During programming the seven segment display outputs “FLASH...”. When finished, the seven segment display outputs “donE”.

◆ Status Indicators

These indicators show the status of the CPU Module.



- RDY
- RUN
- ALM
- ERR
- BAT
- M-ALM

Table 6 Status LED

LED	Description
RDY	ON when the controller has detected valid firmware and has started.
RUN	ON when PLC is running.
ALM	ON when an alarm is active.
ERR	ON at initial power up while firmware is loading. Turns off if firmware is valid. ON when a critical error occurs requiring a power cycle to recover.
BAT	ON when the battery needs replacing.
M-ALM	ON when JL100 (Mechatrolink Master) chip initialization fails.

■ **USB Status Indicator**

This indicator shows the status of the USB memory.

Indicator Name	Indicator Status	Status	Description
USB ACTIVE	 Not lit	No USB memory device	No USB memory device has been inserted yet, or the USB memory device is ready to be removed.
	 Lit	USB memory device inserted	A USB memory device is inserted.
	 Flashing	Accessing USB memory	The USB memory is being accessed.

■ **MECHATROLINK-III Status Indicators**

These indicators show the status of the MECHATROLINK-III communications.

Indicator Name	Color	Status When Lit
 CN LK1 LK2	CN	Green MECHATROLINK-III communications is established with the CPU Module as a slave (i.e., the Connect command is ON).
	LK1	Green MECHATROLINK-III communications are active on PORT1.
	LK2	Green MECHATROLINK-III communications are active on PORT2.

■ **Ethernet Status Indicators**

These indicators show the status of Ethernet communications.

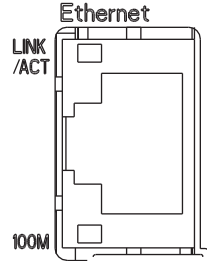
Indicator Name	Color	Status When Not Lit, Lit, or Flashing
 LINK /ACT 100M	LINK/ACT	Yellow Lit: Ethernet link established. Flashing: Ethernet communications activity.
	100M	Green Not lit: 10 M connection Lit: 100 M connection. We do not support GB connections.

10 Self-Configuration

◆ DIP Switch

■ Self-Configuration after Adding Devices such as Servopacks

The controller can automatically configure all the Mechatrolink devices. First, connect and power up all the Mechatrolink nodes (making sure they all have unique station numbers). Then, set the CNFG switch to the ON position and power up the controller. Wait for the RDY LED to come on and the controller will now have the new auto configuration.

Note: Controllers with an existing saved configuration cannot be auto configured until the current configuration is deleted.

■ MotionWorks IEC

The MotionWorks IEC (Express or Pro) configuration can detect the configuration and provide the user with configuration choices. If a StartUp Configuration was already saved on the controller, the self-configure function will not allow new devices to be discovered. In this case, add them offline manually first.

11 MECHATROLINK-III Specifications

The specifications of the MECHATROLINK-III Network Master that is built into the CPU Unit are given in the following table.

Item		Specification	Remarks	
MECHATROLINK communications settings	Communications ASIC	JL-100	-	
	Number of Communications Lines	1	-	
	Number of Communications Ports (Connectors)	2	-	
	Master	Communications Method	M-III	-
		Baud Rate	100 Mbps	-
		Communications Cycle	250 μ s/0.5 ms/ 1 ms/1.5 ms/2 ms/2.5 ms/3 ms/ 3.5 ms/4 ms	-
		Number of Connected Stations	62 stations	-
		Message Relaying	Not Supported.	-
		C2 Messages	Not Supported.	-
		Retries	Supported.	0 to 4 retries
Asynchronous Setting of High-speed Scan Cycle and Communications Cycle	Not supported.	An alarm will occur if setting is attempted.		

◆ CPU Unit Specifications

Item	Specification	
Calendar	Battery backup accurate to 1 minute of error per month.	
Ethernet	10BASE-T, 100BASE-TX Auto-Negotiation / Baseline Wander Correction / Auto-MDIX	
M-III	1981386-1 \times 2 (TycoAMP)	
USB	Connector	DUSB-ARA42-T11A-FA (DDK), type A connector
	Function	USB 2.0 host, 3 speeds (HS/FS/LS), 1 port
Protection	Hardware watchdog timer (PLD): 0 to 510 ms (register setting)	
Relay Output	Contacts normally open for RUN status (RDY indicator lit), and OFF for WDT error status. The relay is built into the Power Supply Unit.	
Backup Circuit	Battery: BR-1/2AA (Panasonic), 3.0 V	

◆ Star Connections

Star connections allow you to connect slave stations through Hub Modules. Each port on a Hub Module connects to only one slave station. You can also connect one additional Hub Module to the first Hub Module.

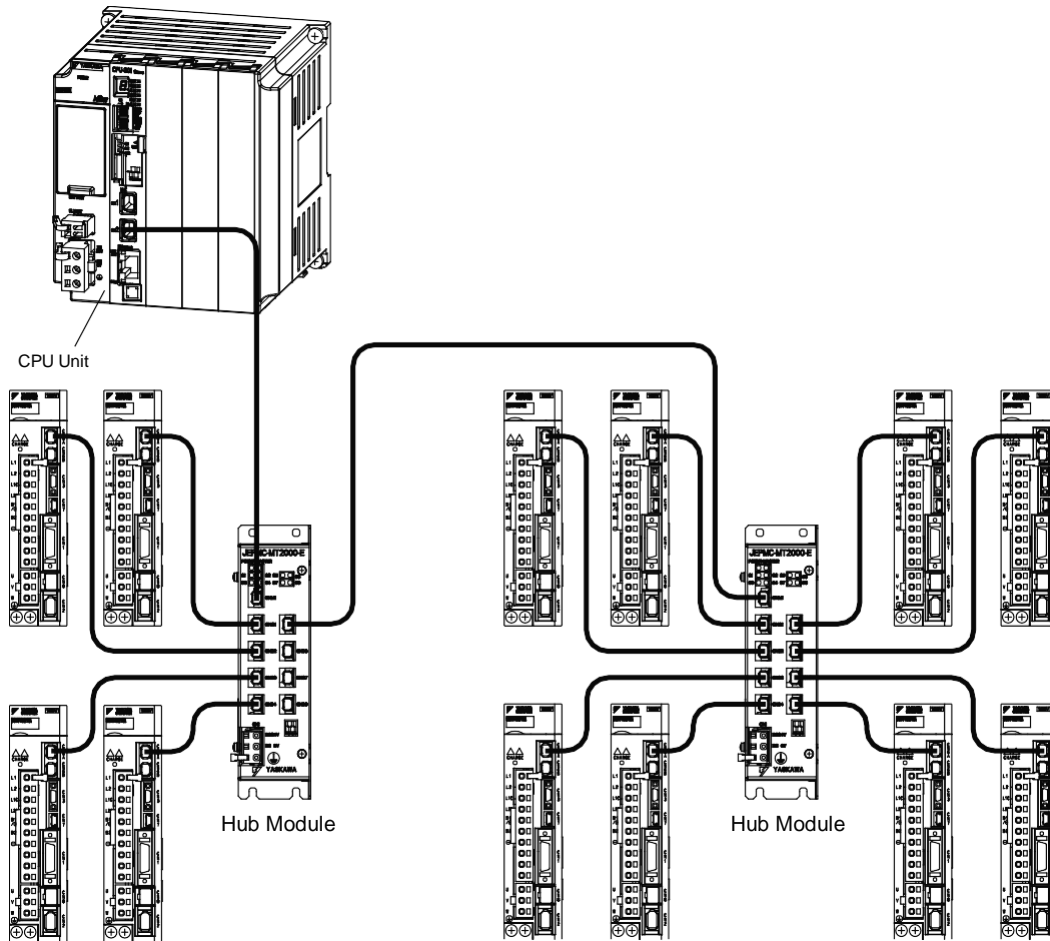

- Note:**
1. Terminating resistors are not required.
 2. The maximum number of stations that you can connect with star connections depends on the communications cycle.

◆ Mixed Cascaded/Star Connections

You can combine both cascaded and star network topologies.

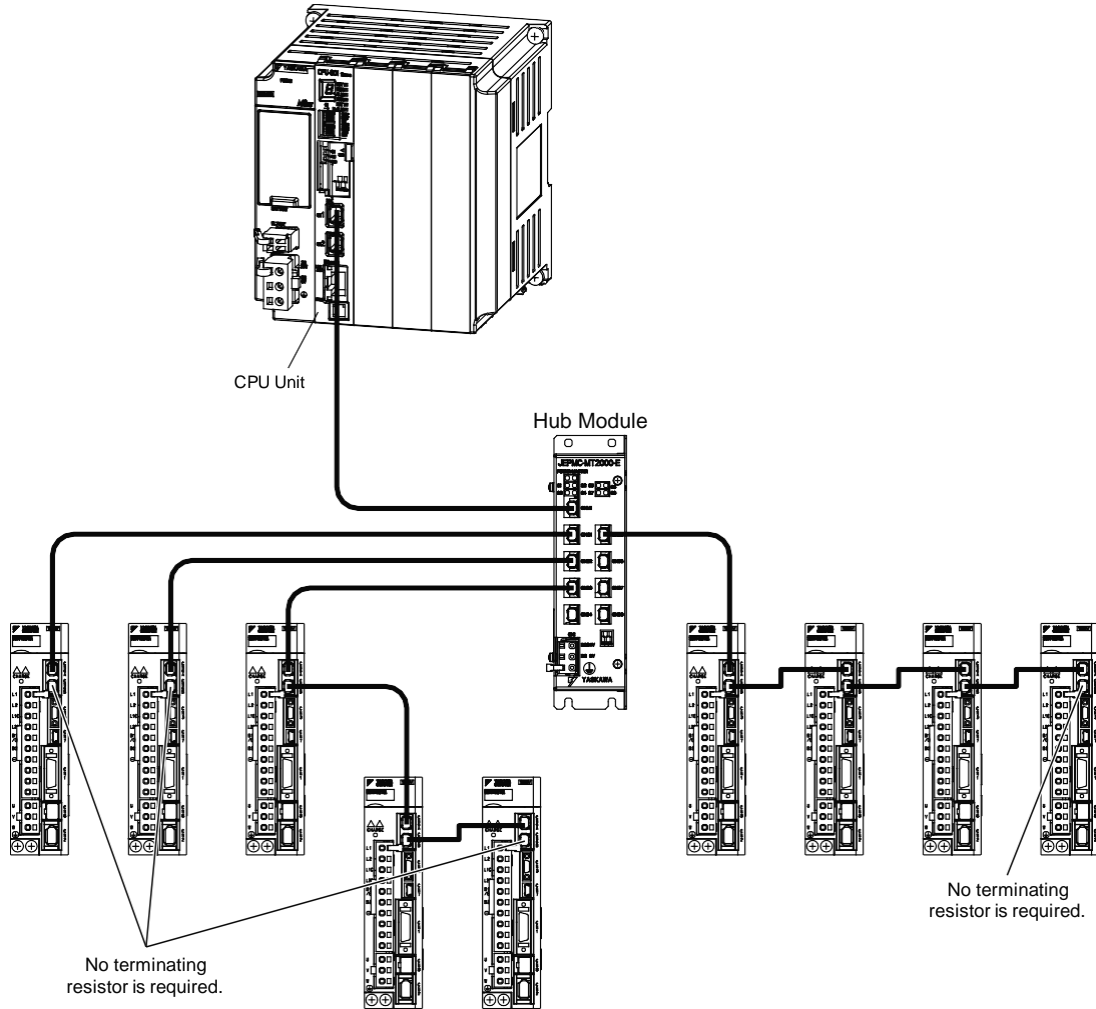

- Note:**
1. Do not connect more than 32 stations to a single CPU Unit port, including the Hub Modules.
 2. The maximum number of stations that you can connect with a mixed cascaded/star connections depends on the communications cycle.

13 MECHATROLINK-III Synchronization between Modules

◆ Timing at Which Modules Are Synchronized

Modules are automatically synchronized when the power supply is cycled.

If you perform any of the following operations after turning ON the power supply, save the settings to flash memory and then cycle the power supply again.

- When operation changes from asynchronous to synchronized as a result of changing the communications cycle
- When operation changes from synchronized to asynchronous or from asynchronous to synchronized as a result of changing the high-speed scan setting
- When the minimum response time in the MPiec controller is changed.

◆ Changing Synchronization Cycles

When the scan cycle is changed, MECHATROLINK communications with all slave stations connected to the SVC32 are reset. Operation automatically changes to synchronized when communications are restored.

MECHATROLINK communications continue for all other Modules.

NOTICE

1. When you change the MECHATROLINK cycle, do so either with the CPU Function Module stopped or when motion commands are not being executed. Otherwise, application operations may be affected.
2. When changing the MECHATROLINK setting, the following operation will occur because MECHATROLINK communications are reset.
 - Position information and zero point return completion information for Servo axes will be lost.

■ Changing the MECHATROLINK Communications Cycle

Operation is automatically synchronized as long as the high-speed scan setting is an integral multiple of the communications cycle.

It is not necessary to cycle the power supply.

NOTICE

If asynchronous operation is set as a result of changing the communications cycle, an alarm will occur for the Servo axis and an I/O error will occur for the I/O station. If this happens, change the setting back to synchronized, save the settings to flash memory, and then cycle the power supply.

14 Devices Connectable via MECHATROLINK-III

◆ Servopacks

The following table shows Servopacks that are compatible with MECHATROLINK-III and can be connected to the controller.

Model	Details
SGDV-□□□□21	Σ-V Series AC Servo amplifiers for rotary motors
SGDV-□□□E21	Σ-V Series Mini AC Servo amplifiers for rotary motors
SGDV-□□□H21A	Σ-V Series 200 VAC Large Capacity AC Servo amplifiers for rotary motors
SGDV-□□□J21A	Σ-V Series 400 VAC Large Capacity AC Servo amplifiers for rotary motors
SGDV-□□□□25	Σ-V Series AC Servo amplifiers for linear motors
SGD7S-□□□A20A	Σ-7 Series 200 VAC Large Capacity AC Servo amplifiers
SGD7W-□□□A20A	Σ-7 Series 200 VAC Large Capacity dual motor AC Servo amplifiers

◆ I/O Modules

The following table shows the module that is compatible with MECHATROLINK-III and can be connected to the controller.

Model	Details
JEPMC-MTD2310-E	64-point I/O Module 24VDC, 64 inputs, 64 outputs

15 Connecting the RLY OUT Connector

The RLY OUT connector connects the status output terminal. It is a normally open contact relay output. The RLY OUT connector is linked to the operation of the RDY indicator: The contacts close when the indicator lights, and they open when the indicator goes out.

Note: When the RDY indicator is lit, the Controller is operating normally. It does not necessarily mean that the user programs are being executed.

◆ RLY OUT Connector Specifications

The operation of the RLY OUT connector is linked to the operation of the RDY indicator on the CPU Unit.

RDY indicator lit: Circuit closed

RDY indicator not lit: Circuit open

■ Contact Ratings

Input Voltage	Current Capacity
24 VDC	0.5 A (resistive load) 0.25 A (inductive load)
125 VAC	0.4 A (resistive load) 0.2 A (inductive load)

◆ RLY OUT Connector Connection Cable

To connect the RLY OUT connector, use a cable with a wire size of AWG 28 to AWG 14 (0.08 to 2.0 mm²) and a maximum outer diameter of 3.4 mm.

The procedure to make the RLY OUT connector cable is the same as for the 24-VDC power supply cable.

Note: You can use the RLY connector on the Power Supply Unit only on the Rack to which the CPU Unit is mounted. On Racks without the CPU Unit, the power supply circuit is always open.

◆ RLY OUT Connector Connection Example

Refer to the following figure for an example of connecting the RLY OUT connector.

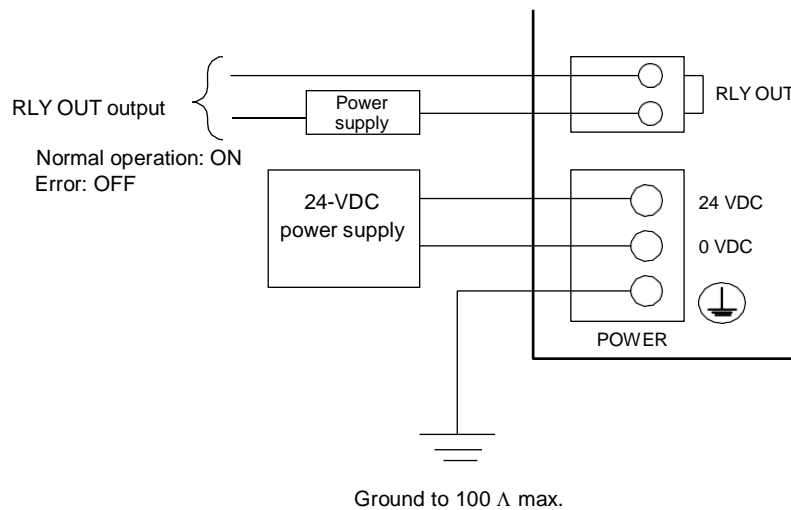

16 Ethernet Connector Details

Connects to other devices by Ethernet (100Base-TX/10Base-T).

◆ Ethernet Connector Specification and Pin Array/Indicator Light

The following table provides the Ethernet connector specifications.

Connector Name	Number of Pins	Connector Model		
		Module Side	Cable Side	Manufacturer
Ethernet	8	RJ-45 CAT5 Socket	RJ-45 CAT5 Plug	Pulse Engineering

The following table provides Ethernet connector pin array / indicator light details.

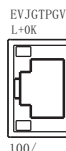

Pin Number	Signal Name	Description
1	TXD+	Transmitted data + side
2	TXD-	Transmitted data – side
3	RXD+	Received data + side
4	–	–
5	–	–
6	RXD-	Received data – side
7	–	–
8	–	–

Display Name	Display Color	Description
LINK	Yellow	Lit: Connect Unlit: Unconnected
100M	Green	Lit: Connected at 100Mbps, or automatically negotiating Unlit: Connected at 10Mbps

◆ Ethernet Cable

For the Ethernet cable, use a twisted pair cable with RJ-45 connector. Yaskawa strongly recommends the use of shielded ethernet cables.

Ethernet Type	Category	Remarks
10Base-T	Category 3 or more	<ul style="list-style-type: none"> When connecting to remote equipment through a hub: Straight cable When connecting to remote equipment without using a hub: Cross cable
100Base-T	Category 5 or more	

◆ Ethernet Connection Examples

The following are examples of Ethernet network connections via 10Base-Tx cable:

■ Connection Example 1 (When using a hub or switch)

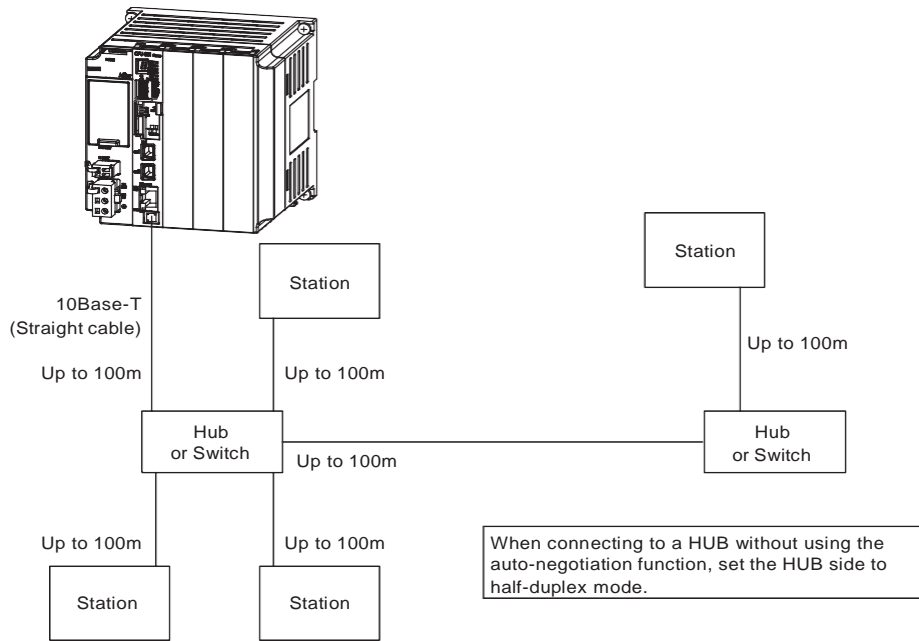

■ Specification

Item	When Connecting to a Repeater HUB	When Connecting to a Switching HUB
Cable Length between Node-HUB	100m or less	100 m or less
Cable Length between HUBs	100m or less	100 m or less
Number of HUBs between Nodes	Up to four	Unlimited

■ Connection Example 2

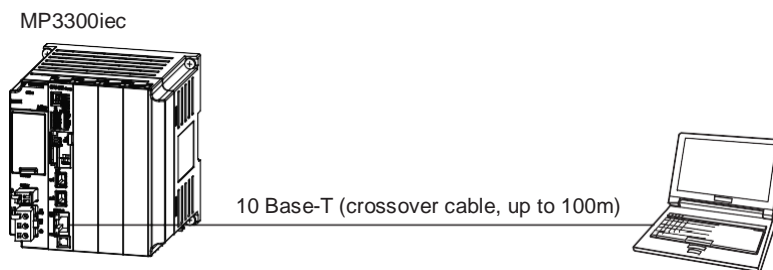

The following are examples of Ethernet network connections via 100Base-Tx cable:

⚠ CAUTION

High frequency wave noise from other devices in the installation environment may cause errors in communications using Ethernet or MECHATROLINK-III connections. When designing a system, use protective measures to avoid the influence of high frequency wave noise as follows:

1. Wiring

Wire Ethernet or MECHATROLINK-III cables so that they are well-separated from other cable systems such as the main circuit or power lines.

2. Communication system (Ethernet)

- Communicate data to a remote device through TCP/IP communication.
- If necessary, increase the number of communication retries.
- Yaskawa strongly recommends shielded Ethernet cables.

3. Attach a ferrite core.

Ethernet: Attach it to the communication port side and the external equipment side of the MP3300iec unit.

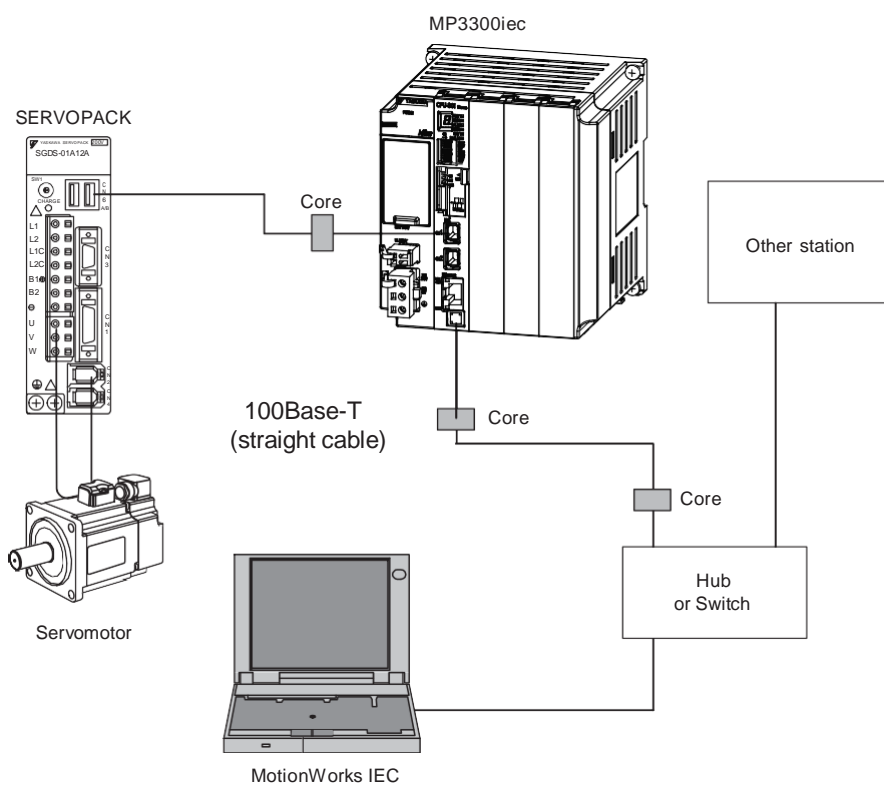

Note: Recommended ferrite core.

Model	Manufacturer
E04SR301334	Seiwa Electric Mfg. Co., Ltd

17 Option Module - AI-01 (Analog Input) Module

◆ Appearance

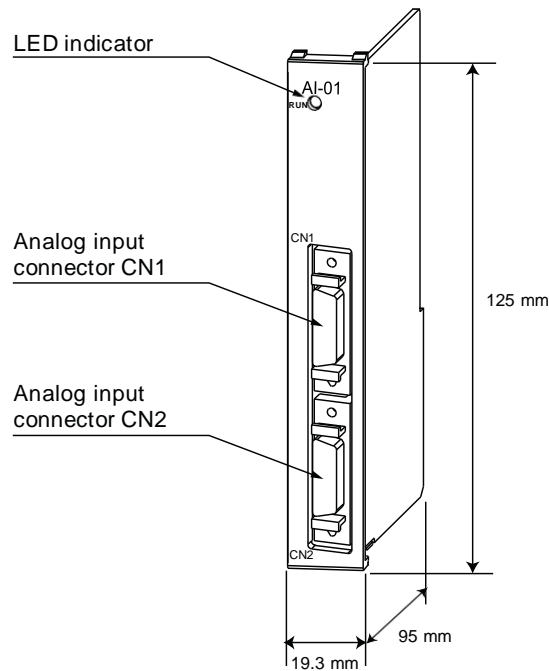

◆ Module Functions

The AI-01 module is an analog input module with voltage and/or current input modes.

◆ Module Specifications

The following table shows the AI-01 Module hardware specifications.

Item		Specifications			
Classification		I/O Module			
Name		AI-01			
Model		JAPMC-AN2300			
Analog Input	Analog Input Range	-10 to +10V	0 to +10V	0 to 20 mA	
	Number of Channels	8 ((4/ connector)×2)			
	Number of Channels to be Used	Any number from 1 to 8			
	Isolation	Between channels: Not isolated. Between input connector and system power supply: Photocoupler isolation			
	Max. Rated Input	±15V	±30 mA		
	Input Impedance	20 kΩ	250 kΩ		
	Resolution	16-bit (-31276 to +31276)	15-bit (0 to +31276)		
	Absolute Accuracy	100 mV Max	0.3 mA Max		
	Accuracy	25°C	±0.1% (±10 mV)	±0.1% (±0.02 mA)	
		0 to 55°C	±0.3% (±30 mV)	±0.3% (±0.06 mA)	
Input Conversion Time		1.4 msec Max			
Connectors		CN1: Input connector CN2: Input connector			
LED Indicator		RUN (green)			

17 Option Module - AI-01 (Analog Input) Module

Item	Specifications
Current Consumption	500 mA Max
Dimensions	125×95 (H×D)
Mass	100 g

◆ LED Indicator



Indicator	Indicator Color	Status when Lit	Status when not Lit
RUN	Green	Normal operation	Operation stopped (no access from CPU)

◆ Connector Specifications

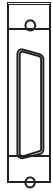

Connector Name	# of Pins	Connector Model		
		Module Side	Cable Side	Manufacturer
CN1/CN2	26	10226-52A3PL	<ul style="list-style-type: none"> Connector 10126-3000VE Shell 10326-52A0-008 (Screw locking), or 10326-52F0-008 (One-touch locking) 	Sumitomo 3M Corporation

Applicable Cable: JEPMC-W6080-oo

◆ Standard Cable Model and External Appearance

Model	Length	External Appearance (JEPMC-W6080-oo)
JEPMC-W6080-05	0.5 m	
JEPMC-W6080-10	1.0 m	
JEPMC-W6080-30	3.0 m	

◆ Connector Pin Arrangement

The AI-01 Module Connector (CN1/CN2) pin arrangement is shown below.

■ CN1 Connector Pin Arrangement

Pin Arrangement Viewed from Wiring Side

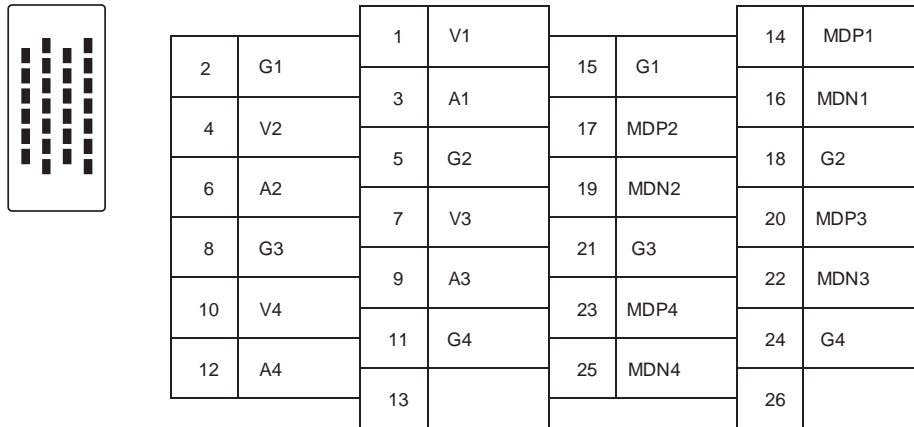

■ CN2 Connector Pin Arrangement

Pin Arrangement Viewed from Wiring Side

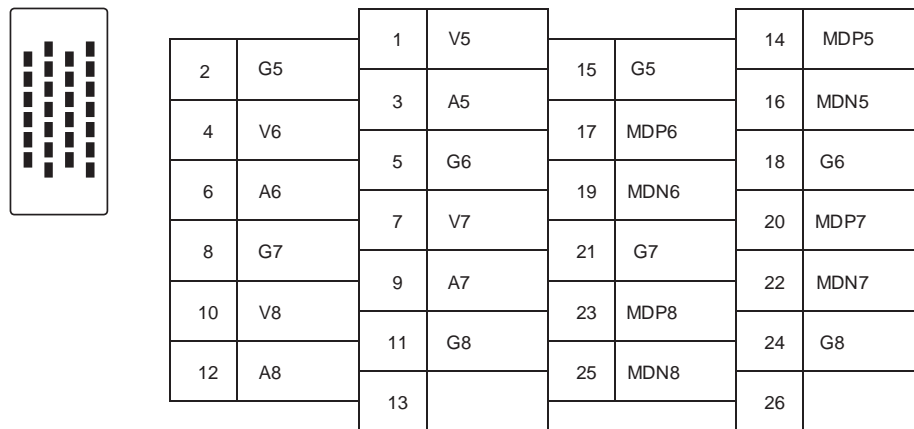

◆ Standard Cable Wiring Table

The wiring table for the standard cable JEPMC-W6080-□□ is shown below.

Pin	Wire Color	Marking		Label on Marking Tube	Signal Name	Function
		Color	Marking			
1	Gray	Red	---	V1/V5	V1/V5	Voltage input 1/5
2	Gray	Black	---	G1V/G5V	G1/G5	Ground 1/5
	Orange	Red	---	G1A/G5A		
3	Orange	Black	---	A1/A5	A1/A5	Current input 1/5
14	Yellow	Red	-	DP1/DP5	MDP1/MDP5	Mode switching terminal 1/5
16	Yellow	Black	-	DN1/DN5	MDN1/MDN5	Mode switching terminal 1/5
4	Pink	Red	--	V2/V6	G2/G6	Voltage input 2/6
	Pink	Black	--	G2V/G6V		Ground 2/6
	Yellow	Black	--	G2A/G6A		

17 Option Module - AI-01 (Analog Input) Module

Pin	Wire Color	Marking		Label on Marking Tube	Signal Name	Function
		Color	Marking			
6	Yellow	Black	--	A2/A6	A2/A6	Current input 2/6
17	White	Red	-	DP2/DP6	MDP2/MDP6	Mode switching terminal 2/6
19	White	Black	-	DN2/DN6	MDN2/MDN6	Mode switching terminal 2/6
7	White	Red	--	V3/V7	V3/V7	Voltage input 3/7
8	White	Black	--	G3V/G7V	G3/G7	Ground 3/7
	Gray	Red	--	G3A/G7A		
9	Gray	Black	--	A3/A7	A3/A7	Current input 3/7
20	Gray	Red	-	DP3/DP7	MDP3/MDP7	Mode switching terminal 3/7
22	White	Black	-	DN3/DN7	MDN3/MDN7	Mode switching terminal 3/7
10	Orange	Red	--	V4/V8	V4/V8	Voltage input 4/8
11	Orange	Black	--	GV4/GV8	G4/G8	Ground 4/8
	Pink	Red	--	G4A/G8A		
12	Pink	Black	--	A4/A8	A4/A8	Current input 4/8
23	Orange	Red	--	DP4/DP8	MDP4/MDP8	Mode switching terminal 4/8
25	Orange	Black	--	DN4/DN8	MDN4/MDN8	Mode switching terminal 4/8

DANGER

Columns “Label on Marking Tube”, “Signal Name”, and “Function” display the values for connectors CN1 and CN2 in the format “CN1/CN2”, respectively.

◆ Circuit Configuration

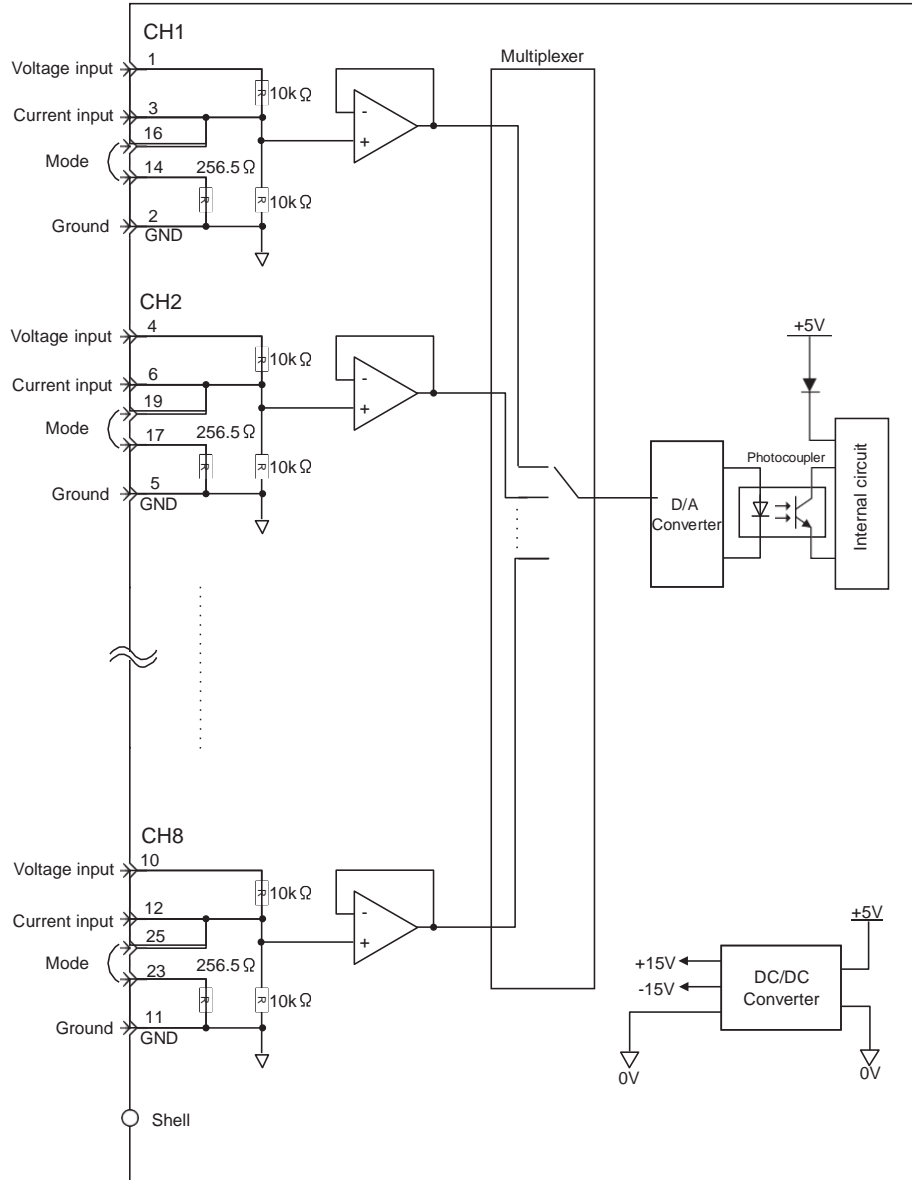

◆ CN1 Connector Connection Example

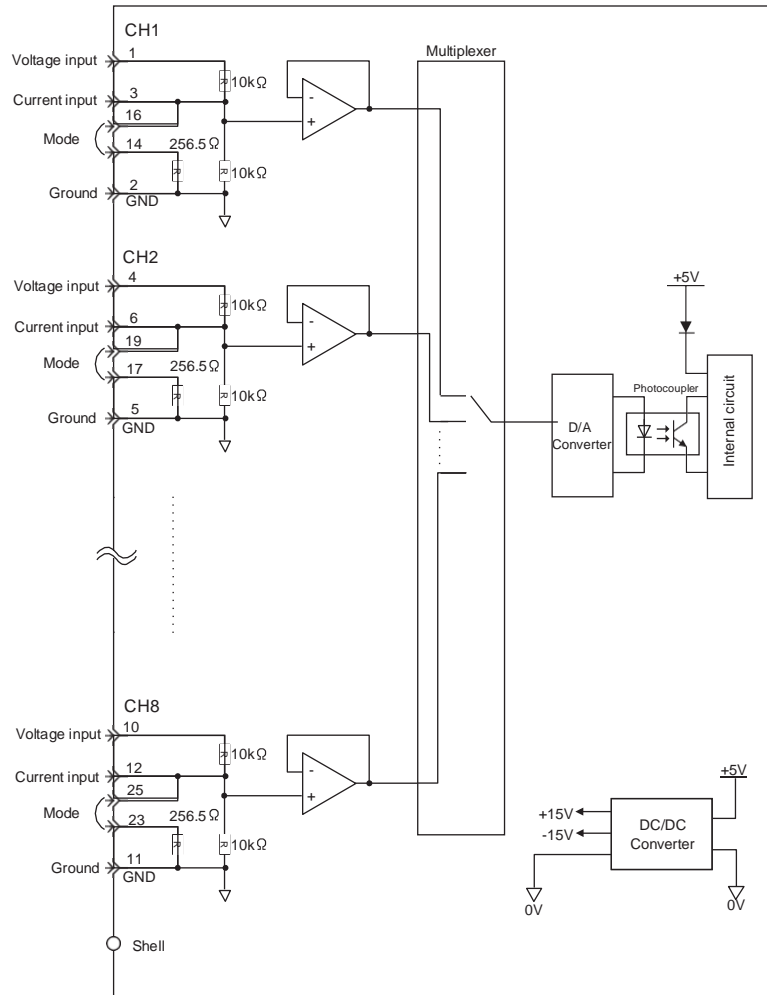

⚠ DANGER

- Use the standard cable (JEPMC-W6080-□□) for AI-01 Modules to connect to external devices. Use a relay terminal block to connect the AI-01 module to external devices because the wiring distance varies between the AI-01 module and each external device.
- Ground the cable shield between an external device and the relay terminal block on the external device side.

18 Option Module - AO-01 (Analog Output) Module

◆ Appearance

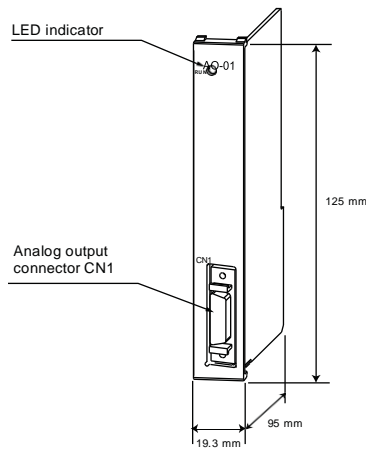

◆ Module Functions

The AO-01 module has four channels for analog output. Two types of analog output ranges are available; -10 to +10V and 0 to +10V.

◆ Module Specifications

The following table shows the AO-01 Module hardware specifications.

Item		Specifications		
Name		AO-01		
Model		JAPMC-AN2310-E		
Analog Output	Number of Channels	4		
	Isolation	Between channels: Not isolated. Between output connector and system power supply: Photocoupler isolation		
	Analog Output Range	±10V	0 to +10V	
	Resolution	16-bit (-31276 to +31276)	15-bit (0 to +31276)	
	Absolute Accuracy	100 mV Max	0.3 mA Max	
	Accuracy	25°C	±0.1% (±10 mV)	
		0 to 55°C	±0.3% (±30 mV)	
Input Conversion Time	1.2 msec Max			
Connectors	CN1: Output connector			
LED Indicator	RUN (green)			
Current Consumption	500 mA Max			
Dimensions	125 × 95 (H×D)			
Mass	90 g			

◆ Indicators



Indicator	Indicator Color	Status when Lit	Status when not Lit
RUN	Green	Normal operation	Operation stopped (no access from CPU)

◆ Connector Specifications



Name	Connector Name	# of Pins	Connector Model		
			Module Side	Cable Side	Manufacturer
Analog Output Connector	CN1	20	10220-52A3PL	<ul style="list-style-type: none"> Connector 10126-3000VE Shell 10326-52A0-008 (Screw locking), or 10326-52F0-008 (One-touch locking) 	Sumitomo 3M Corporation

Applicable Cable: JEPMC-W6090-oo

◆ Standard Cable Model and External Appearance

Model	Length	External Appearance (JEPMC-W6090-oo)
JEPMC-W6090-05	0.5 m	
JEPMC-W6090-10	1.0 m	
JEPMC-W6090-30	3.0 m	

◆ CN1 Pin Layout Diagram

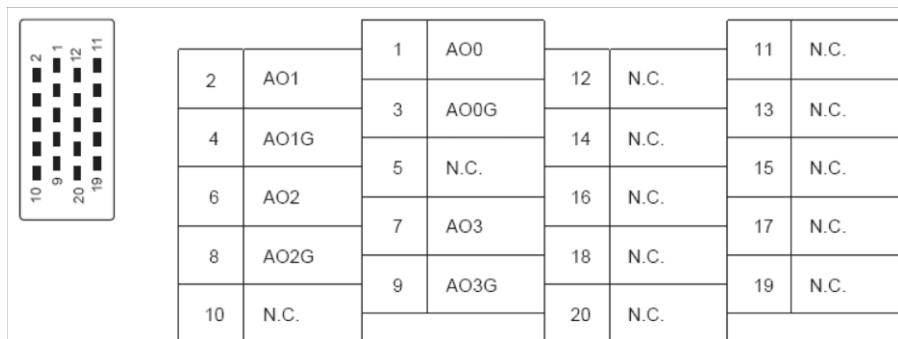

◆ Standard Cable Wiring Table

The following shows the pin arrangement for standard cable JEPMC-W6090.

Pin	Wire Color	Marking		Function
			Color	
1	Orange	Red		Analog Output 0
2	Gray	Red		Analog Output 1
3	Orange	Black		Ground 0
4	Gray	Black		A_Pulse+
5				
6	White	Red		Pulse input ground
7	Yellow	Red		(-)
8	White	Black		(-)
9	Yellow	Black		C-Phase latch input common (5V)
10~20	Twisted-pair cable			

◆ AO-01 Module Connector Connection Example

CN1 Connector Connection Example

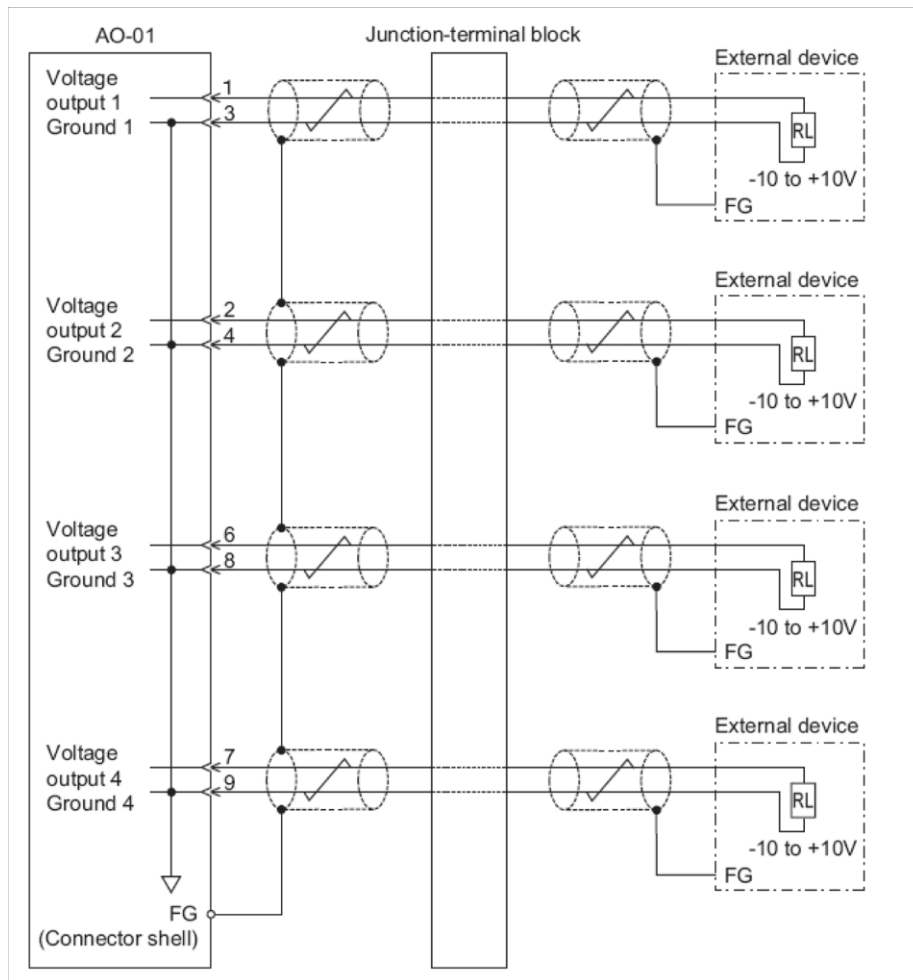

⚠ DANGER

- Use the AO-01 standard cable (JEPMC-W6090-□□) for the connection to the external device. Use the junction terminal block because the distance between the external devices and the module are different as seen on the above diagram.
- Ground the cable shield between the external devices and the junction terminal block by the external device side.

19 Option Module - DO-01 (Digital Output) Module

◆ Appearance/Indicators

◆ Module Functions

The DO-01 module is equipped with 64 digital outputs.

◆ Output Circuit Specifications

The following table shows the DO-01 Module output circuit specifications.

Item	Specifications
Outputs	64 points
Output Format	Transistor/open collector, sink mode output
Isolation Method	Photocoupler
Output Voltage	+ 24VDC (+19.2 to +28.8V)
Output Current	100 mA Max
Leakage Current When OFF	0.1 mA Max
ON Time/OFF Time	ON: 0.5 ms Max OFF: 1 ms Max
Number of Commons	8 points
Protection Circuit	Fuse connected to each common line
Fuse Rating	1A
Error Detection	Fuse blowout detection

◆ DO-01 Digital Output Circuit (Sink Mode Output) Connection Example

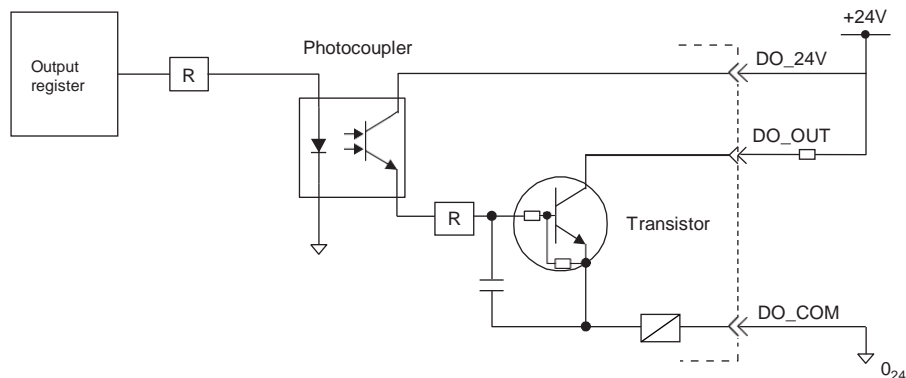

⚠ DANGER

A fuse is inserted into the output common line of the DO-01 Module for circuit protection. However, the fuse may not be blown out in the cases such as layer shorts in outputs. To ensure the circuit protection, provide a protective element such as fuse in each output as shown in the above diagram.

◆ DO-01 Module Connections

Connects the DO-01 Module to external output signals.

External outputs: 64 points



Name	Connector Name	No of Pins	Connector Model		
			Module Side	Cable Side	Manufacturer
External I/O Connector	CN1/CN2	50	10250-52A2JL	<ul style="list-style-type: none"> • Connector • 10150-3000VE • Shell • 10350-52A0-008 • (Screw locking), or • 10350-52F0-008 • (One-touch locking) 	Sumitomo 3M Corporation

Applicable Cable: JEPMC-W6060-oo

◆ Standard Cable Model and External Appearance

Name	Model	Length	External Appearance (JEPMC-W6060-oo)
Cables for DO-01 Modules	JEPMC-W6060-05	0.5 m	
	JEPMC-W6060-10 ²⁴ ₂₅	1.0 m	
	JEPMC-W6060-30	3.0 m	

◆ Connector Pin Arrangement

The DO-01 Module Connector (CN1 and CN2) pin arrangement is shown below.

■ CN1 Connector Pin Arrangement

Pin Arrangement Viewed from Wiring Side



2	DO_00	1	+24V_1	27	DO_01	26	OV_1
4	DO_04	3	DO_02	29	DO_15	28	DO_03
6	OV_1	5	DO_06	31	OV_1	30	DO_07
8	DO_08	7	+24V_2	33	DO_09	32	OV_2
10	DO_12	9	DO_10	35	DO_13	34	DO_11
12	OV_2	11	DO_14	37	OV_2	36	DO_15
14	DO_16	13	+24V_3	39	DO_17	38	OV_3
16	DO_20	15	DO_18	41	DO_21	40	DO_19
18	OV_3	17	DO_22	43	OV_3	42	DO_23
20	DO_24	19	+24V_4	45	DO_25	44	OV_4
22	DO_28	21	DO_26	47	DO_29	46	DO_27
24	OV_4	23	DO_30	49	OV_4	48	DO_31

19 Option Module - DO-01 (Digital Output) Module

■ CN2 Connector Pin Arrangement

Pin Arrangement Viewed from Wiring Side



2	DO_32	1	+24V_5	27	DO_33	26	OV_5
4	DO_36	3	DO_34	29	DO_37	28	DO_35
6	OV_5	5	DO_38	31	OV_5	30	DO_39
8	DO_40	7	+24V_6	33	DO_41	32	OV_6
10	DO_44	9	DO_42	35	DO_45	34	DO_43
12	OV_6	11	DO_46	37	OV_6	36	DO_47
14	DO_48	13	+24V_7	39	DO_49	38	OV_7
16	DO_52	15	DO_50	41	DO_53	40	DO_51
18	OV_7	17	DO_54	43	OV_7	42	DO_55
20	DO_56	19	+24V_8	45	DO_57	44	OV_8
22	DO_60	21	DO_58	47	DO_61	46	DO_59
24	OV_8	23	DO_62	49	OV_8	48	DO_63

◆ Standard Cable Wiring Table

The wiring table for the standard cable JEPMC-W6060-□□ is shown below

Pin	Wire Color	Marking	Signal Name	Function
1	Orange	—	+24V_1/5	24V power supply 1/5
2	Gray	—	DO_00/32	Digital output 0/32
3	White	—	DO_02/34	Digital output 2/34
4	Yellow	—	DO_04/36	Digital output 4/36
5	Pink	—	DO_06/38	Digital output 6/38
6	Orange	— — —	0V_1/5	Common ground 1/5
7	Gray	— — —	+24V_2/6	24V power supply 2/6
8	White	— — —	DO_08/40	Digital output 8/40
9	Yellow	— — —	DO_10/42	Digital output 10/42
10	Pink	— — —	DO_12/44	Digital output 12/44
11	Orange	— — — —	DO_14/46	Digital output 14/46
12	Gray	— — — —	0V_2/6	Common ground 2/6
13	White	— — — —	+24V_3/7	24V power supply 3/7
14	Yellow	— — — —	DO_16/48	Digital output 16/48
15	Pink	— — — —	DO_18/50	Digital output 18/50
16	Orange	— — — — —	DO_20/52	Digital output 20/52
17	Gray	— — — — —	DO_22/54	Digital output 22/54
18	White	— — — — —	0V_3/7	Common ground 3/7
19	Yellow	— — — — —	+24V_4/8	24V power supply 4/8
20	Pink	— — — — —	DO_24/58	Digital output 24/58
21	Orange	— — — — — Continuous	DO_26/68	Digital output 26/60
22	Gray	— — — — — Continuous	DO_28/60	Digital output 28/62
23	White	— — — — — Continuous	DO_30/62	Digital output 30/64
24	Yellow	— — — — — Continuous	0V_4/8	Common ground 4/8
25	Pink	— — — — — Continuous	N.C	
26	Orange	—	0V_1/5	Common ground 1/5
27	Gray	—	DO_01/33	Digital output 1/33
28	White	—	DO_03/35	Digital output 3/35

19 Option Module - DO-01 (Digital Output) Module

Pin	Wire Color	Marking	Signal Name	Function
29	Yellow	---	DO_05/37	Digital output 5/37
30	Pink	---	DO_07/39	Digital output 7/39
31	Orange	---	0V_1/5	Common ground 1/5
32	Gray	---	0V_2/6	Common ground 2/6
33	White	---	DO_09/41	Digital output 9/41
34	Yellow	---	DO_11/43	Digital output 11/43
35	Pink	---	DO_13/45	Digital output 13/45
36	Orange	---	DO_15/47	Digital output 15/47
37	Gray	---	0V_2/6	Common ground 2/6
38	White	---	0V_3/7	Common ground 3/7
39	Yellow	---	DO_17/49	Digital output 17/49
40	Pink	---	DO_19/51	Digital output 19/51
41	Orange	----- Continuous	DO_21/53	Digital output 21/53
42	Gray	----- Continuous	DO_23/55	Digital output 23/55
43	White	----- Continuous	0V_3/7	Common ground 3/7
44	Yellow	----- Continuous	0V_4/8	Common ground 4/8
45	Pink	----- Continuous	DO_25/57	Digital output 25/57
46	Orange	-----	DO_27/59	Digital output 27/59
47	Gray	-----	DO_29/61	Digital output 29/61
48	White	-----	DO_31/63	Digital output 31/63
49	Yellow	-----	0V_4/8	Common ground 4/8
50	Pink	-----	N.C	

DANGER

Columns “Signal Name” and “Function” display the values for connectors CN1 and CN2 in the format “CN1/CN2” respectively.

20 Option Module - LIO-01/02 Module

◆ Appearance

■ External Appearance

The following figure shows the external appearance of the LIO-01/02 Modules

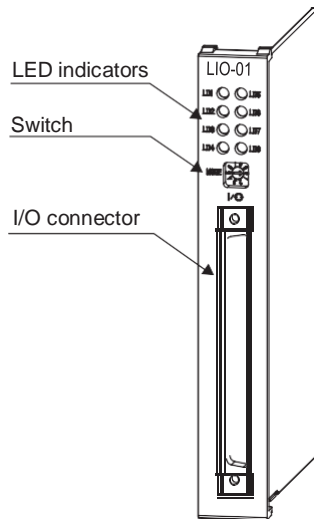

◆ Outline of Functions

The LIO-01 Module provides digital I/O and encoder input functions. There are 16 digital inputs (DI) and 16 digital outputs (DO) for the digital I/O function. There is also one encoder input.

The following diagram gives an outline of the LIO-01 Module functions. The only functional difference between the LIO-01 and the LIO-02 is the active state of the output circuits

Refer to LIO-01 Digital Output Circuit (Sink Mode Output) Connection Example on page 46 and Refer to LIO-02 Digital Output Circuit (Source Mode Output) Connection Example on page 46.

◆ LED Indicators and Switch Settings

The LIO-02 Module status display LED indicators (LD1 to LD8) change based on the SW1 rotary switch settings. The following table shows the ON/OFF indicator display for digital input and digital output.

Indicator	Color	SW1	Status when Lit	
LD1 to LD8	Green	0	Board Status Indicators	
			LD1	Normal operation: Lit, Error: Not lit
			LD2	DI-00 to DI-07 status. Lit when any digital input is turned ON.
			LD3	DO-00 to DO-07 status. Lit when any digital output is turned ON.
			LD4	Pulse A/B input. Lit when phase A/B is turned ON.
			LD5	Normal operation: Lit, Error: Not lit
			LD6	DI-08 to DI-15 status. Lit when any digital input is turned ON.
			LD7	DO-08 to DO-15 status. Lit when any digital output is turned ON.
		LD8	Pulse Z input. Lit when phase Z is turned ON.	
		1	Digital input indicators: When DI00 to DI07 turn ON, corresponding indicators (LD1 to LD8) are lit.	
		2	Digital input indicators: When DI08 to DI15 turn ON, corresponding indicators (LD1 to LD8) are lit.	
		3	Digital output indicators: When DO00 to DO07 turn ON, corresponding indicators (LD1 to LD8) are lit.	
		4	Digital output indicators: When DO08 to DO15 turn ON, corresponding indicators (LD1 to LD8) are lit.	
		5	PI input Indicators	
			LD1	Pulse A input
LD2	Pulse B input		LD6	Phase-Z latch
LD3	Pulse Z input		LD7	Digital input latch
LD4	-		LD8	-

LD1 ○ LD5
 LD2 ○ LD6
 LD3 ○ LD7
 LD4 ○ LD8

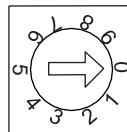

Indicators

SW1

◆ Specifications

■ Module Specifications

Item	Specifications
Name	LIO-01/02
Model	JAPMC-IO2300/JAPMC-IO2301
Digital Inputs	16 inputs 24VDC, 4.1 mA, combined sink mode/source mode inputs (DI_01 also used for position registration latch.)
Digital Outputs	16 outputs 24VDC transistor open-collector outputs, sink mode (-01)/Source mode (-02) outputs.
Encoder Input	Phase A/B/Z inputs Phase-A/B: 5V differential input, not isolated, Max frequency: 4 MHz Phase-Z: 5V/12V photocoupler input, Max frequency: 500 kHz Latch input Position registration latch on phase-C or DI_01.
Switches	Rotary switch (SW1)
Dimensions (mm)	125 x 95 (H x D)
Mass	80 g

■ Input Circuit Specifications

Item	Specifications
Inputs	16 points
Input Format	Sink mode/Source mode input
Isolation Method	Photocoupler
Input Voltage	$\pm 24\text{VDC}$, $\pm 20\text{mv}$
Input Current	4.1 mA (typ.)
ON Voltage/Current	15V min./2.0 mA min.
OFF Voltage/Current	5V Max/1.0 mA Max
ON Time/OFF Time	ON: 0.5 ms Max OFF: 0.5 ms Max
Number of Commons	8 points (DI_COM0: DI_00 to DI_07, DI_COM1: DI_08 to DI_15)
Other Functions	DI_01 is shared with position registration latch. If DI_01 is turned ON while position registration latch inputs are enabled, the encoder position will be latched.

◆ Digital Input Circuit (Sink Mode Input) Connection Example

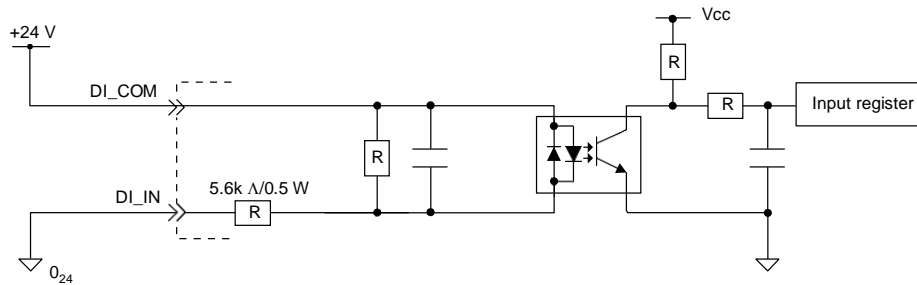

◆ Digital Input Circuit (Source Mode Input) Connection Example

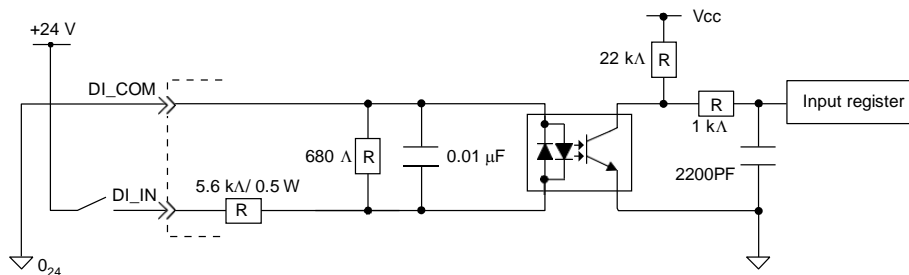

◆ Output Circuit

The following table shows the LIO-01/02 Module output circuit specifications.

Item	Specifications
Outputs	16 points
Output Format	LIO-01 Transistor, open collector sink mode outputs
	LIO-02 Transistor, open collector source mode outputs
Isolation Method	Photocoupler
Output Voltage	$+24\text{VDC}$, $\pm 20\text{mv}$
Output Current	100 mA Max
Leakage Current When OFF	0.1 mA Max
ON Time/OFF Time	ON: 1 ms Max OFF: 1 ms Max

Item	Specifications
Number of Commons	16 points
Protection Circuit	The fuses are not for circuit protection. They are for fire protection at output shorts. Attach a fuse externally to each output if circuit protection is required.
Error Detection	Blown fuse detection
Other Functions	DO_01 is shared with encoder position detection

◆ LIO-01 Digital Output Circuit (Sink Mode Output) Connection Example

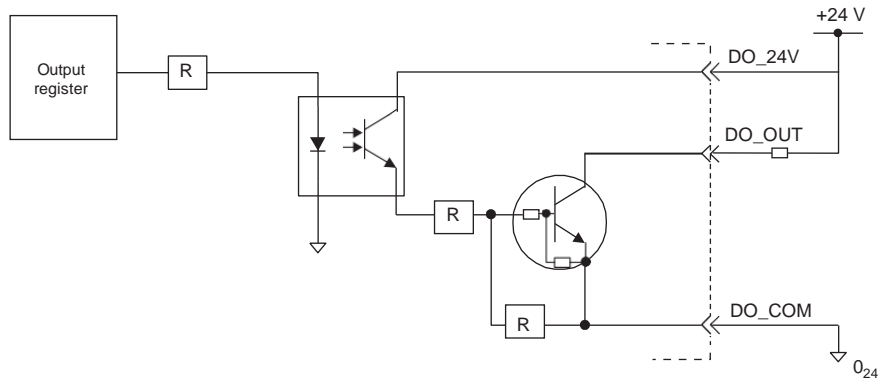

◆ LIO-02 Digital Output Circuit (Source Mode Output) Connection Example

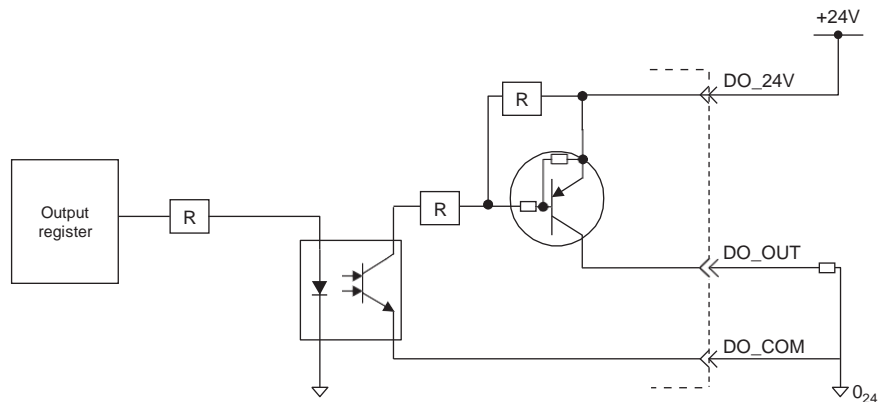

◆ Pulse Input Circuit

The following table shows the LIO-01/02 Module encoder circuit specifications.

Item	Specifications
Number of Encoders	1 (Phase-A/B/Z input)
Encoder Circuit	Phase-AB: 5V differential input, not isolated, Max frequency: 4 MHz Phase-Z: 5V/12V photocoupler input, Max frequency: 500 kHz
Input Mode	Phase-A/B, signed, incremental/decremental
Latch Input	Position registration latch on phase-Z or DI_01. Response time: 5 μs Max for phase-Z input; 60 μs Max for DI_01 input.

◆ Encoder Circuit Connection Example

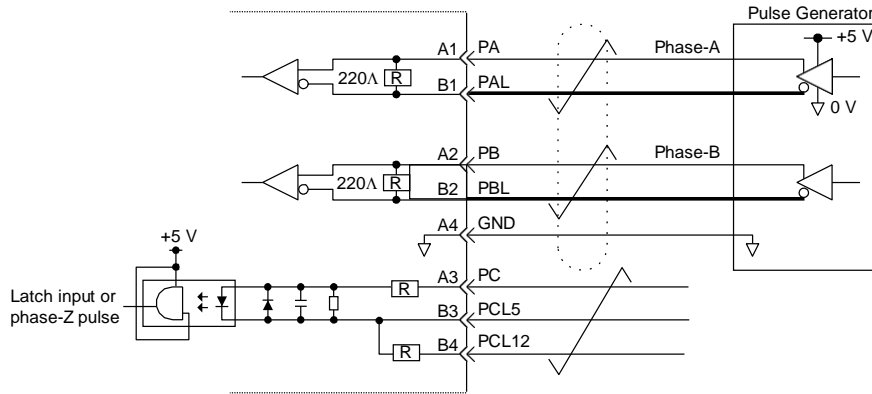

◆ LIO-01/02 Standard Cable Wiring Table

■ Connector Pin Arrangement

The following table shows the connector pin arrangement for LIO-01/02 Modules viewed from the wiring side.



Pin	Wire Color	Wire Marking		Signal Name	I/O	Function
		Color	Marking			
A1	Orange	Red	—	PA	I	Phase-A pulse (+)
A2	Gray	Red	—	PB	I	Phase-B pulse (+)
A3	White	Red	—	PC	I	Phase-C pulse (+)
A4	Yellow	Red	—	GND	I	Pulse input ground
A5	Pink	Red	—	DO_COM	P	Output common
A6	Orange	Red	— —	DO_24V	P	+24VDC input
A7	Gray	Red	— —	DO_15	O	Output 15
A8	White	Red	— —	DO_13	O	Output 13
A9	Yellow	Red	— —	DO_11	O	Output 11
A10	Pink	Red	— —	DO_09	O	Output 9
A11	Orange	Red	— — —	DO_07	O	Output 7
A12	Gray	Red	— — —	DO_05	O	Output 5
A13	White	Red	— — —	DO_03	O	Output 3
A14	Yellow	Red	— — —	DO_01	O	Output 1
A15	Pink	Red	— — —	DI_15	I	Input 15
A16	Orange	Red	— — — —	DI_13	I	Input 13
A17	Gray	Red	— — — —	DI_11	I	Input 11
A18	White	Red	— — — —	DI_09	I	Input 9
A19	Yellow	Red	— — — —	DI_07	I	Input 7
A20	Pink	Red	— — — —	DI_05	I	Input 5
A21	Orange	Red	— — — — Continuous	DI_03	I	Input 3
A22	Gray	Red	— — — — Continuous	DI_01	I	Input 1
A23	White	Red	— — — — Continuous	DI_COM0	P	Input common 0
A24	Shield			FG	-	Frame ground
B1	Orange	Black	—	PAL	I	Phase-A pulse (-)
B2	Gray	Black	—	PBL	I	Phase-B pulse (-)
B3	White	Black	—	PCL5	I	Phase-C pulse (-5V input)
B4	Yellow	Black	—	PCL12	I	Phase-C pulse (-12V input)

Pin	Wire Color	Wire Marking		Signal Name	I/O	Function
		Color	Marking			
B5	Pink	Black	—	DO_COM	P	Output common
B6	Orange	Black	— —	DO_24V	P	+24V input
B7	Gray	Black	— —	DO_14	O	Output 14
B8	White	Black	— —	DO_12	O	Output 12
B9	Yellow	Black	— —	DO_10	O	Output 10
B10	Pink	Black	— —	DO_08	O	Output 8
B11	Orange	Black	— — —	DO_06	O	Output 6
B12	Gray	Black	— — —	DO_04	O	Output 4
B13	White	Black	— — —	DO_02	O	Output 2
B14	Yellow	Black	— — —	DO_00	O	Output 0
B15	Pink	Black	— — — —	DI_14	I	Input 14
B16	Orange	Black	— — — —	DI_12	I	Input 12
B17	Gray	Black	— — — —	DI_10	I	Input 10
B18	White	Black	— — — —	DI_08	I	Input 8
B19	Yellow	Black	— — — —	DI_06	I	Input 6
B20	Pink	Black	— — — —	DI_04	I	Input 4
B21	Orange	Black	— — — — Continuous	DI_02	I	Input 2
B22	Gray	Black	— — — — Continuous	DI_00	I	Input 0
B23	White	Black	— — — — Continuous	DI_COM1	P	Input common 1
B24	Shield			FG	-	Frame ground

• P: Power supply input; I: Input signal; O: Open-collector output

◆ Connector Specifications

Connects the external I/O signals and encoder input signals.

External output: 16 points, Encoder input: 1 channel

Name	Connector Name	# of Pins	Connector Model		
			Module	Cable	Manufacturer
I/O Connector	I/O	48	FCN-365P048-AU	FCN-360C048-E (cover), FCN-361J048-AU (jack)	Fujitsu component

◆ Cables

Name	Model Number	Length	(JEPMC-W2061-oo)
Cable for LIO-01/02 Modules	JEPMC-W2061-A5	0.5 m	
	JEPMC-W2061-01	1.0 m	
	JEPMC-W2061-03	3.0 m	

◆ LIO-01 Module Connections

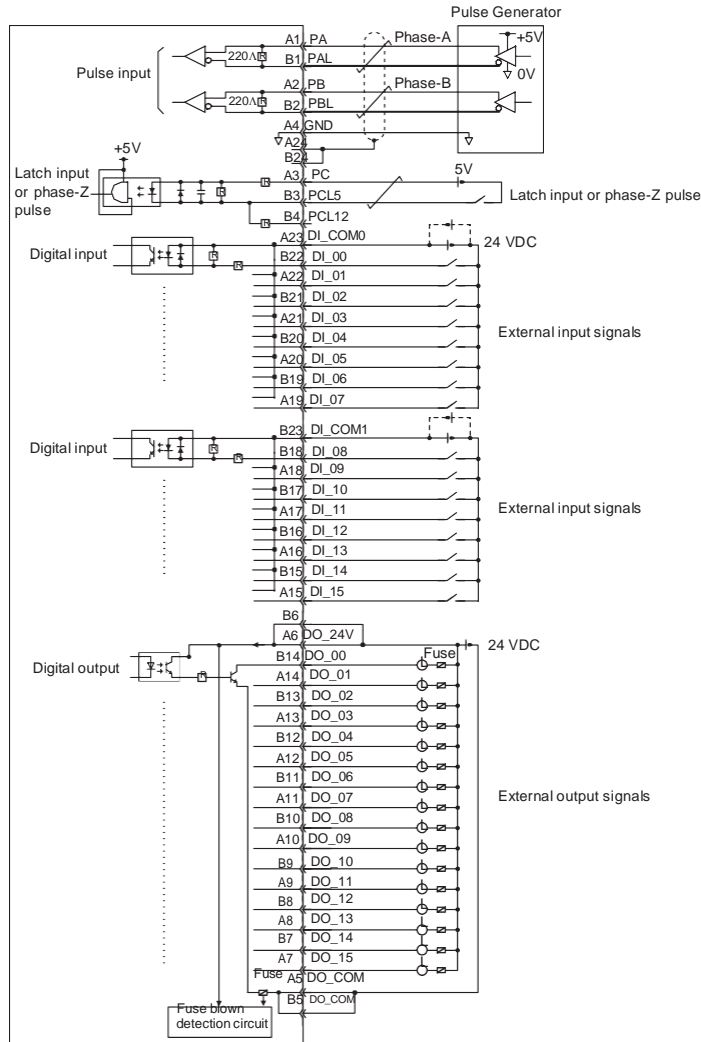

⚠ DANGER

- Connect a fuse suitable for the load specifications in the output signal circuit in series with the load. If an external fuse is not connected, load shorts or overloads could result in fire, destruction of the load device, or damage to the output element.
- The pins A5 and B5, and the pins A6 and B6 are internally connected. Connect them externally as well.

◆ LIO-02 Module Connections

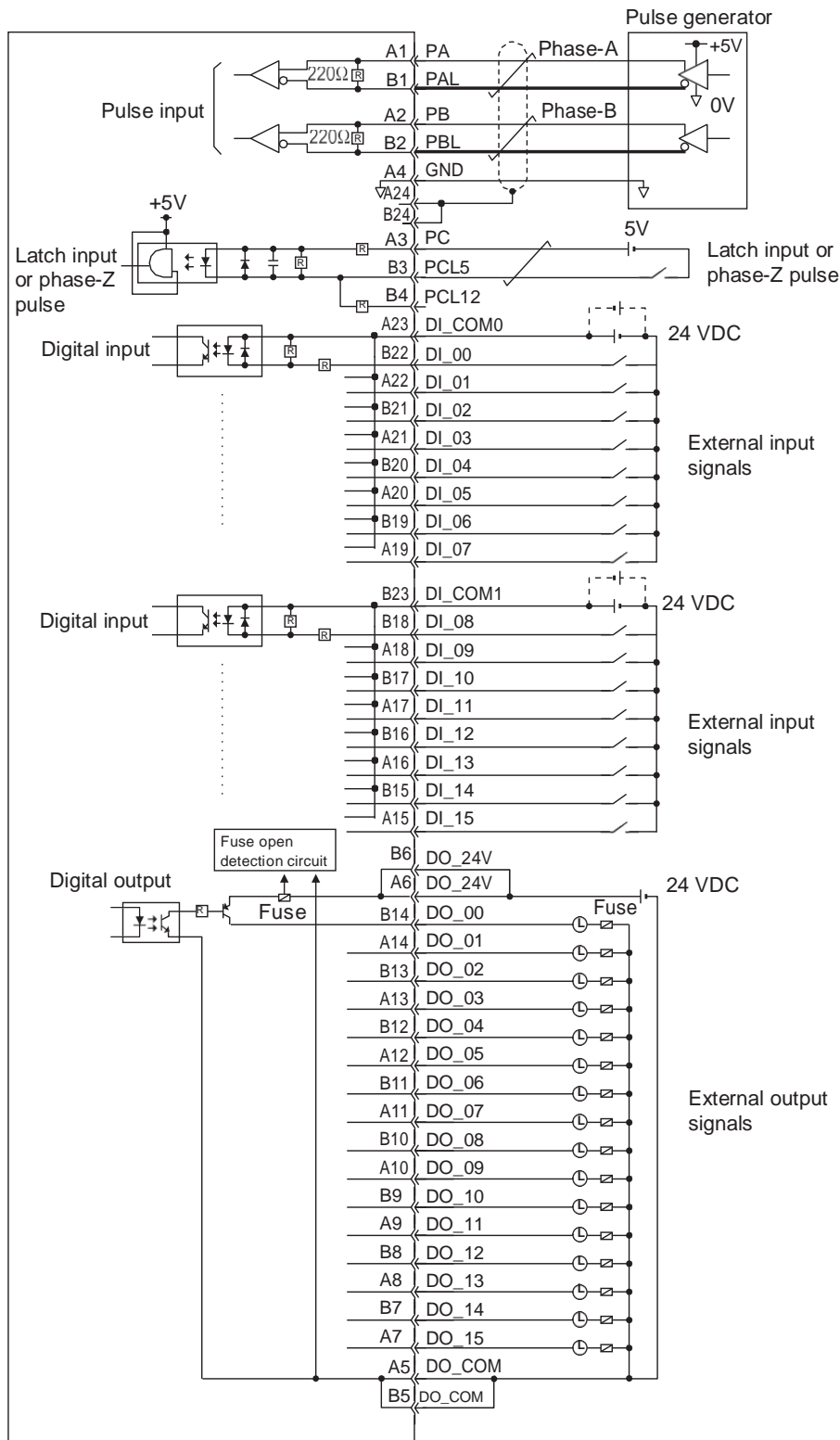

Ⓛ Load
 ⊠ External Fuse

21 Option Module - LIO-04/05 Modules

◆ External Appearance

The following figure shows the external appearance of the LIO-04/05 Modules.

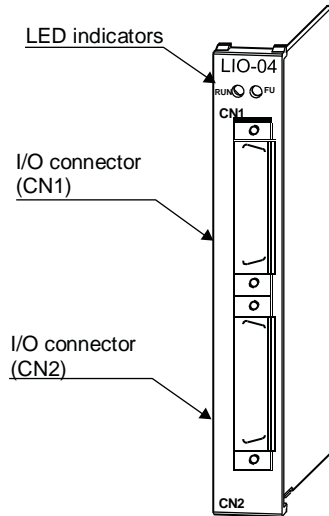

◆ Outline of Functions

The LIO-04/05 Modules are Optional Boards for the MP2300Siec which provide a digital I/O function. There are 32 digital inputs (DI) and 32 digital outputs (DO) (sink mode outputs) for the digital I/O function.

◆ Indicators

The following table shows the status of LIO-04/05 Module LED indicators.



Indicator Name	Indicator Color	Status
RUN	Green	Lit: Module normal Not lit: Module error
FU	Red	Lit: One of the output protection fuses is blown. Not lit: All of the output protection fuses are normal.

⚠ DANGER

The burnout detection circuit will not function when there is no external 24V power supply.

◆ Switch Settings

The LIO-04/05 Module status display the LED indicators (LD1 to LD8) change based on the SW1 rotary switch setting. The following table shows the ON/OFF indicator display for digital input and digital output.

Indicator	Color	SW1	Status when Lit	
LD1 to LD8	Green	0	Board Status Indicators	
			LD1	Normal operation: Lit, Error: Not lit
			LD2	DI_00 to DI_07 status. Lit when any digital input is turned ON.
			LD3	DO_00 to DO_07 status. Lit when any digital output is turned ON.
			LD4	Pulse A/B input. Lit when phase A/B is turned ON.
			LD5	Normal operation: Lit, Error: Not lit
			LD6	DI_08 to DI_15 status. Lit when any digital input is turned ON.
			LD7	DO_08 to DO_15 status. Lit when any digital output is turned ON.
		LD8	Pulse Z input. Lit when phase Z is turned ON.	
		1	Digital input indicators: When DI_00 to DI_07 turn ON, corresponding indicators LD1 to LD8 are lit.	
		2	Digital input indicators: When DI_08 to DI_15 turn ON, corresponding indicators LD1 to LD8 are lit.	
		3	Digital output indicators: When DO_00 to DO_07 turn ON, corresponding indicators LD1 to LD8 are lit.	
		4	Digital output indicators: When DO_08 to DO_15 turn ON, corresponding indicators LD1 to LD8 are lit.	
		5	PI Input Indicators	
			LD1	Pulse A input
LD2	Pulse B input		LD6	Phase-Z latch
LD3	Pulse Z input		LD7	Digital input latch
LD4	-		LD8	-

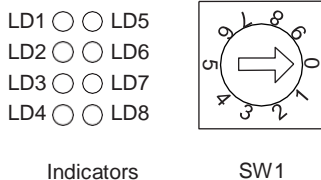

◆ Module Specifications

The following table shows the hardware specifications of the LIO-04/05 Module.

Item	Specifications
Name	LIO-04/LIO-05
Model	JAPMC-IO2303/JAPMC-IO2304
Digital Inputs	32 inputs 24VDC, 4.1 mA, combined sink mode/source mode inputs (DI_00, 01, 16, and 17 also used for interrupts.)
	Simultaneously ON Inputs 16 points (8 inputs/common): At ambient temperature of 55°C and 24VDC 10 points (5 inputs/common): At ambient temperature of 55°C and 28.8VDC Refer to the following characteristics graph for details.
Digital Outputs	32 outputs 24VDC transistor open-collector outputs, sink mode outputs
Indicators	RUN (green) ERR (red)
Dimensions (mm)	125 x 95 (H x D)
Mass	80 g

◆ Input Circuit Specifications

The following table shows the LIO-04/05 Modules input circuit specifications.

Item	Specifications
Inputs	32 points
Input Format	Sink mode, source mode input
Isolation Method	Photocoupler (PS2805-4)
Input Voltage	±24VDC (+19.2 to +28.8V)
Input Current	4.1 mA (typ.)
ON Voltage/Current	15VDC min./2.0 mA min.
OFF Voltage/Current	5VDC min./1.0 mA min.
ON Time/OFF Time	ON: 0.5 ms Max OFF: 0.5 ms Max
Number of Commons	8 points

◆ Digital Input Circuit (Sink Mode Input) Connection Example

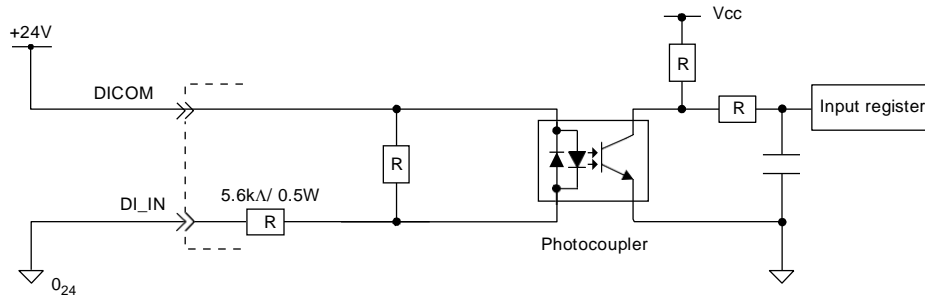

◆ Digital Input Circuit (Source Mode Input) Connection Example

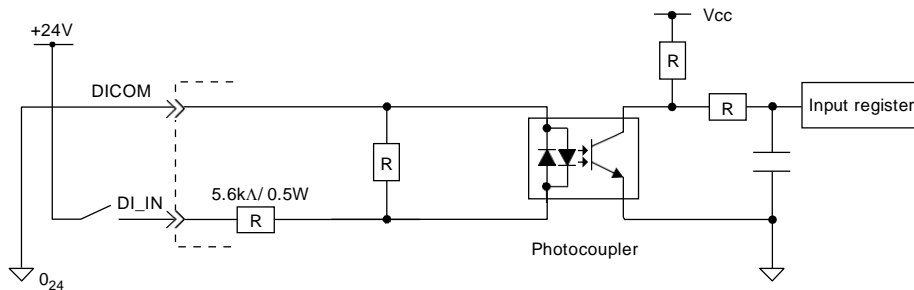

◆ Output Circuit

The following table shows the LIO-04/05 Module's output circuit specifications.

Item	Specifications
Outputs	32 points
Output Format	LIO-04 Transistor, sink mode output LIO-05 Transistor, source mode output
Isolation Method	Photocoupler
Output Voltage	+24VDC (+19.2 to +28.8VDC)
Output Current	100 mA Max
Leakage Current When OFF	0.1 mA Max

Item	Specifications
ON Time/OFF Time	ON: 0.5 ms Max OFF: 1 ms Max
Number of Commons	1 per 8 outputs
Protection Circuit	The fuses are not for circuit protection. They are for fire protection at output shorts. Attach a fuse externally to each output if circuit protection is required.
Fuse Rating	1A
Error Detection	Fuse blowout detection

◆ LIO-04 Digital Output Circuit (Sink Mode Output) Connection Example

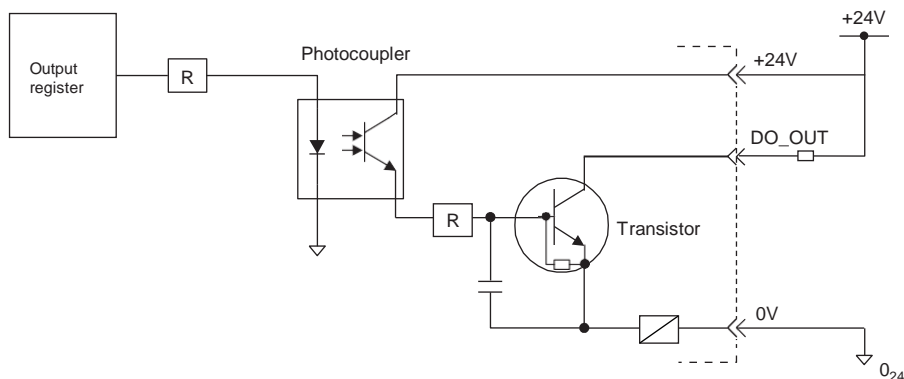

◆ LIO-05 Digital Output Circuit (Source Mode Output) Connection Example

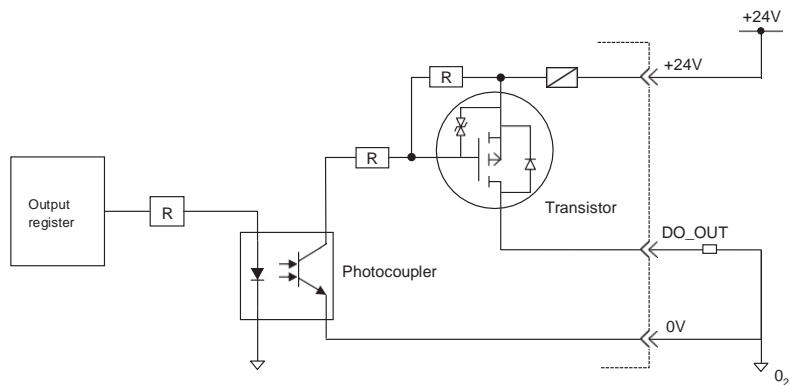

◆ LIO-04 Module Connector Pin Arrangement

The LIO-04 Module Connector (CN1 and CN2) pin arrangements are shown below.

■ CN1 Connector Pin Arrangement

Pin Arrangement Viewed from Wiring Side

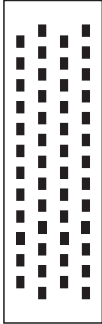

2	DI_00	1	DICOM_1	27	DI_01	26	N.C.
4	DI_04	3	DI_02	29	DI_05	28	DI_03
6	DICOM_2	5	DI_06	31	N.C.	30	DI_07
8	DI_10	7	DI_08	33	DI_11	32	DI_09
10	DI_14	9	DI_12	35	DI_15	34	DI_13
12	DO_00	11	N.C.	37	DO_01	36	N.C.
14	N.C.	13	DO_02	39	OV_1	38	DO_03
16	DO_04	15	+24V_1	41	DO_05	40	N.C.
18	N.C.	17	DO_06	43	N.C.	42	DO_07
20	DO_10	19	DO_08	45	DO_11	44	DO_09
22	+24V_2	21	N.C.	47	N.C.	46	OV_2
24	DO_14	23	DO_12	49	DO_15	48	DO_13

■ CN2 Connector Pin Arrangement

Pin Arrangement Viewed from Wiring Side

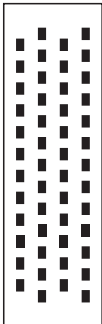

2	DI_16	1	DICOM_3	27	DI_17	26	N.C.
4	DI_20	3	DI_18	29	DI_21	28	DI_19
6	DICOM_4	5	DI_22	31	N.C.	30	DI_23
8	DI_26	7	DI_24	33	DI_27	32	DI_25
10	DI_30	9	DI_28	35	DI_31	34	DI_29
12	DO_16	11	N.C.	37	DO_17	36	N.C.
14	N.C.	13	DO_18	39	OV_3	38	DO_19
16	DO_20	15	+24V_3	41	DO_21	40	N.C.
18	N.C.	17	DO_22	43	N.C.	42	DO_23
20	DO_26	19	DO_24	45	DO_27	44	DO_25
22	+24V_4	21	N.C.	47	N.C.	46	OV_4
24	DO_30	23	DO_28	49	DO_31	48	DO_29

• P: Power supply input, I: Input signal, O: Open collector output

◆ Standard Cable Wiring Table

The wiring table for the standard cable JEPMC-W6060-□□ is shown below.

Pin	Wire Color	Markings	Signal Name	I/O	Function
1	Orange	—	DICOM_1/3	P/P	Digital Input common 1/3
2	Gray	—	DI_00/16	I/I	Digital input 0/16 (shared with interrupt input)
3	White	—	DI_02/18	I/I	Digital input 2/18
4	Yellow	—	DI_04/20	I/I	Digital input 4/20
5	Pink	—	DI_06/22	I/I	Digital input 6/22

Pin	Wire Color	Markings	Signal Name	I/O	Function
6	Orange	----	DICOM_2/4	P/P	Digital Input common 2/4
7	Gray	----	DI_08/24	I/I	Digital input 8/24
8	White	---	DI_10/26	I/I	Digital input 10/26
9	Yellow	---	DI_12/28	I/I	Digital input 12/28
10	Pink	----	DI_14/30	I/I	Digital input 14/30
11	Orange	-----	N.C.		
12	Gray	-----	DO_00/16	O/O	Digital output 0/16
13	White	-----	DO_02/18	O/O	Digital output 2/18
14	Yellow	-----	N.C.		
15	Pink	-----	+24V_1/3	P/P	Digital output 24V supply 1/3
16	Orange	-----	DO_04/20	O	Digital output 4/20
17	Gray	-----	DO_06/22	O	Digital output 6/22
18	White	-----	N.C.		
19	Yellow	-----	DO_08/24	O/O	Digital output 8
20	Pink	-----	DO_10/26	O/O	Digital output 10
21	Orange	----- Continuous	N.C.		
22	Gray	----- Continuous	+24V_2/4	P	Digital Output 24V supply 2/4
23	White	----- Continuous	DO_12/28	O	Digital output 12/28
24	Yellow	----- Continuous	DO_14/30	O	Digital output 14/30
25		----- Continuous	N.C.		
26	Orange	---	N.C.		
27	Gray	—	DI_01/17	I/I	Digital input 1/17 (shared with interrupt input)
28	White	—	DI_03/19	I/I	Digital input 3/19
29	Yellow	—	DI_05/21	I/I	Digital input 5/21
30	Pink	—	DI_07/23	I/I	Digital input 7/23
31	Orange	---	N.C.		
32	Gray	---	DI_09/25	I/I	Digital input 9/25
33	White	---	DI_11/27	I/I	Digital input 11/27
34	Yellow	---	DI_13/29	I/I	Digital input 13/29
35	Pink	---	DI_15/31	I/I	Digital input 15/31
36	Orange	-----	N.C.		
37	Gray	-----	DO_01/17	O/O	Digital output 1/17
38	White	-----	DO_03/19	O/O	Digital output 3/19
39	Yellow	-----	0V_1/3	P/P	Digital Output 0VDC common 1/3
40	Pink	-----	N.C.		
41	Orange	----- Continuous	DO_05/21	O/O	Digital output 5/21
42	Gray	----- Continuous	DO_07/23	O/O	Digital output 7/23
43	White	----- Continuous	N.C.		
44	Yellow	----- Continuous	DO_09/25	O/O	Digital output 9/25
45	Pink	----- Continuous	DO_11/27	O/O	Digital output 11/27
46	Orange	-----	0V_2/4	P/P	Digital Output 0VDC common 2/4
47	Gray	-----	N.C.		
48	White	-----	DO_13/29	O/O	Digital output 13/19
49	Yellow	-----	DO_15/31	O/O	Digital output 15/31
50	Pink	-----	N.C.		



Columns “Signal Name”, “I/O”, and “Function” display the values for connectors CN1 and CN2 in the format “CN1/CN2” respectively.

◆ LIO-05 Module Connector Pin Arrangement

The LIO-05 Module Connector (CN1 and CN2) pin arrangements are shown below.

■ CN1 Connector Pin Arrangement

Pin Arrangement Viewed from Wiring Side



2	DI_00	1	DICOM_1	27	DI_01	26	N.C.
4	DI_04	3	DI_02	29	DI_05	28	DI_03
6	DICOM_2	5	DI_06	31	N.C.	30	DI_07
8	DI_10	7	DI_08	33	DI_11	32	DI_09
10	DI_14	9	DI_12	35	DI_15	34	DI_13
12	DO_00	11	N.C.	37	DO_01	36	N.C.
14	N.C.	13	DO_02	39	OV_1	38	DO_03
16	DO_04	15	+24V_1	41	DO_05	40	+24V_1
18	N.C.	17	DO_06	43	N.C.	42	DO_07
20	DO_10	19	DO_08	45	DO_11	44	DO_09
22	+24V_2	21	N.C.	47	+24V_2	46	OV_2
24	DO_14	23	DO_12	49	DO_15	48	DO_13

24
25
49
50

• P: Power supply input, I: Input signal, O: Open collector output

■ CN2 Connector Pin Arrangement

Pin Arrangement Viewed from Wiring Side



2	DI_16	1	DICOM_3	27	DI_17	26	N.C.
4	DI_20	3	DI_18	29	DI_21	28	DI_19
6	DICOM_4	5	DI_22	31	N.C.	30	DI_23
8	DI_26	7	DI_24	33	DI_27	32	DI_25
10	DI_30	9	DI_28	35	DI_31	34	DI_29
12	DO_16	11	N.C.	37	DO_17	36	N.C.
14	N.C.	13	DO_18	39	OV_3	38	DO_19
16	DO_20	15	+24V_3	41	DO_21	40	+24V_3
18	N.C.	17	DO_22	43	N.C.	42	DO_23
20	DO_26	19	DO_24	45	DO_27	44	DO_25
22	+24V_4	21	N.C.	47	+24V_4	46	N.C.
24	DO_30	23	DO_28	49	DO_31	48	DO_29

◆ Standard Cable Wiring Table

The wiring table for the standard cable JEPMC-W6060-□□ is shown below.

Pin	Wire Color	Markings	Signal Name	I/O	Function
1	Orange	—	DICOM_1/3	I/I	Digital Input common 1/3
2	Gray	—	DI_00/16	I/I	Digital input 0/16
3	White	—	DI_02/18	I/I	Digital input 2/18
4	Yellow	—	DI_04/20	I/I	Digital input 4/20
5	Pink	—	DI_06/22	I/I	Digital input 6/22

Pin	Wire Color	Markings	Signal Name	I/O	Function
6	Orange	----	DICOM_2/4	P/P	Digital Input common 2/4
7	Gray	----	DI_08/24	I/I	Digital input 8/24
8	White	---	DI_10/26	I/O	Digital input 10/26
9	Yellow	---	DI_12/28	I/O	Digital input 12/28
10	Pink	----	DI_14/30	I/O	Digital input 14/30
11	Orange	-----	N.C.		
12	Gray	-----	DO_00/16	O/O	Digital output 0/16
13	White	-----	DO_02/18	O/O	Digital output 2/18
14	Yellow	-----	N.C.		
15	Pink	-----	+24V_1/3	P/P	Digital Output 24V supply 1/3
16	Orange	-----	DO_04/20	O	Digital output 4/20
17	Gray	-----	DO_06/22	O	Digital output 6/22
18	White	-----	N.C.		
19	Yellow	-----	DO_08/24	O	Digital output 8/24
20	Pink	-----	DO_10/26	O	Digital output 10/26
21	Orange	----- Continuous	N.C.		
22	Gray	----- Continuous	+24V_2/4	P	Digital Output 24V supply 2/4
23	White	----- Continuous	DO_12/28	O	Digital output 12/28
24	Yellow	----- Continuous	DO_14/30	O	Digital output 14/30
25	Pink	----- Continuous	N.C.		
26	Orange	---	N.C.		
27	Gray	---	DI_01/17	I/I	Digital input 1/17
28	White	---	DI_03/19	I/I	Digital input 3/19
29	Yellow	---	DI_05/21	I/I	Digital input 5/21
30	Pink	---	DI_07/23	I/I	Digital input 7/23
31	Orange	----	N.C.		
32	Gray	----	DI_09/25	I/I	Digital input 9/25
33	White	---	DI_11/27	I/I	Digital input 11/27
34	Yellow	---	DI_13/29	I/I	Digital input 13/29
35	Pink	---	DI_15/31	I/I	Digital input 15/31
36	Orange	-----	N.C.		
37	Gray	-----	DO_01/17	O/O	Digital output 1/17
38	White	-----	DO_03/19	O/O	Digital output 3/19
39	Yellow	-----	0V_1/3	P/P	Digital Output 0VDC common 1/3
40	Pink	-----	+24V_1/3	P/P	Digital Output 24V supply 1/3
41	Orange	----- Continuous	DO_05/21	O/O	Digital output 5/21
42	Gray	----- Continuous	DO_07/23	O/O	Digital output 7/23
43	White	----- Continuous	N.C.		
44	Yellow	----- Continuous	DO_09/25	O/O	Digital output 9/25
45	Pink	----- Continuous	DO_11/26	O/O	Digital output 11/26
46	Orange	-----	0V_2/4		Digital Output 0VDC common 2/4
47	Gray	-----	+24V_2/4		Digital Output 24V supply 2/4
48	White	-----	DO_13/29	O/O	Digital output 13/29
49	Yellow	-----	DO_15/31	O/O	Digital output 15/31
50	Pink	-----	N.C.		

⚠ DANGER

Columns “Signal Name”, “I/O”, and “Function” display the values for connectors CN1 and CN2 in the format “CN1/ CN2” respectively.

◆ LIO-04 Module Connector Connection Examples

■ CN1 Connector Connection Example

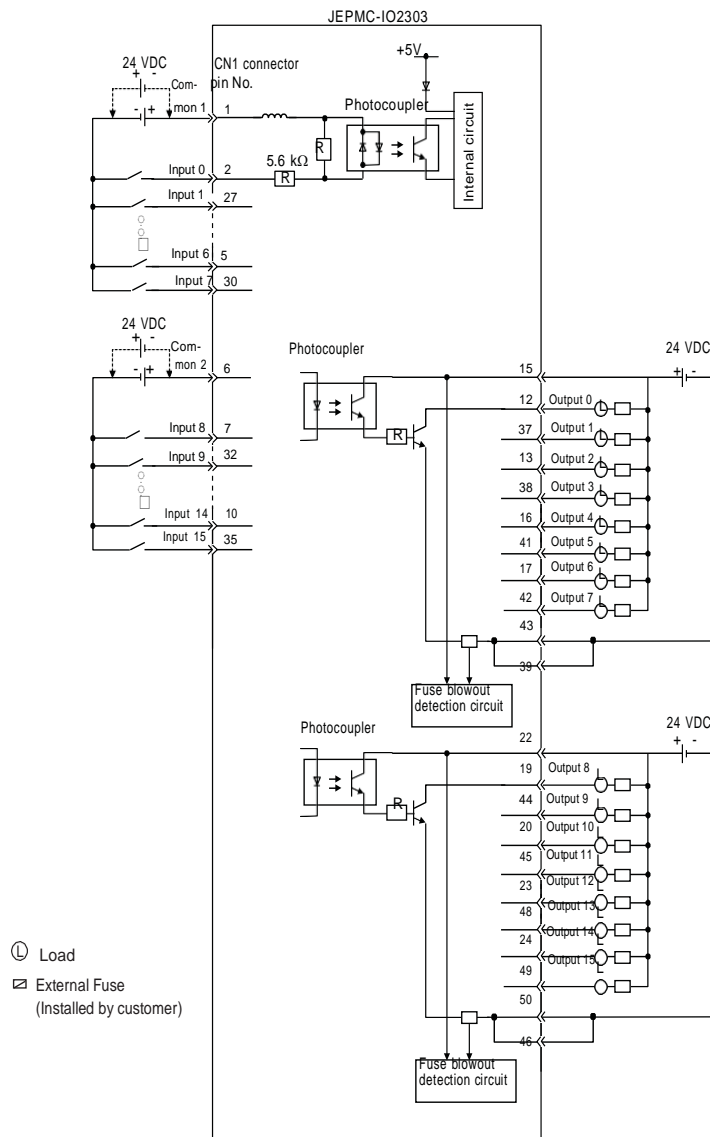

⚠ DANGER

- Check the polarity of the external power supply when wiring. An adverse connection may cause a load malfunction.
- The pins 39 and 43 and the pins 46 and 50 are internally connected. Connect them externally as well.

■ CN2 Connector Connection Example

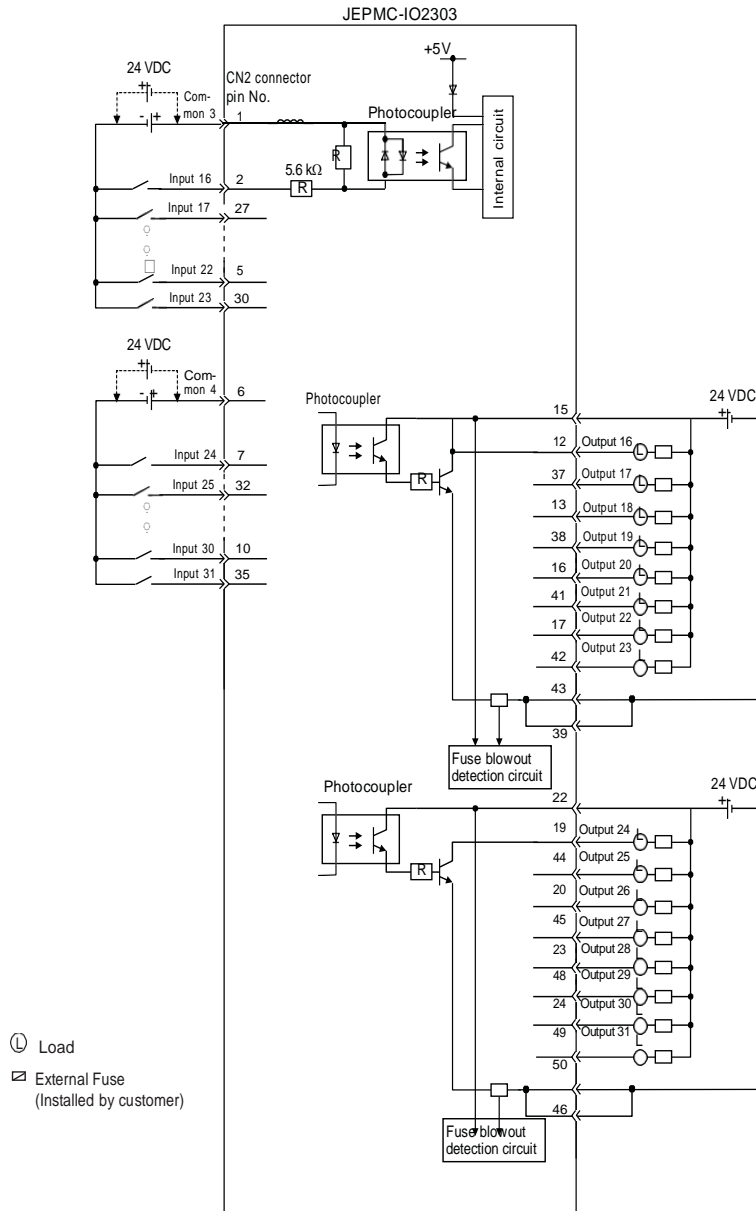

⚠ DANGER

- Check the polarity of the external power supply when wiring. An adverse connection may cause a load malfunction.
- The pins 39 and 32 and the pins 46 and 50 are internally connected. Connect them externally as well.

◆ LIO-05 Module Connector Connection Examples

■ CN1 Connector Connection Example

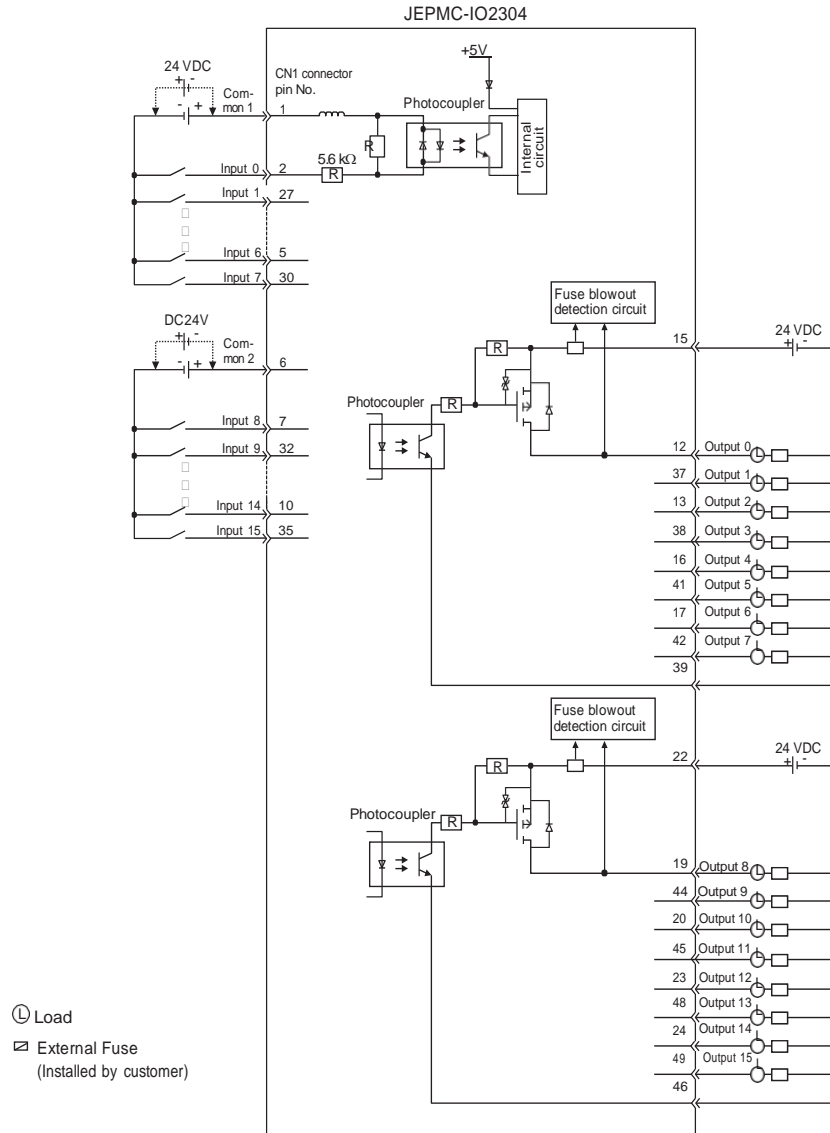

⚠ DANGER

Check the polarity of the external power supply when wiring. An adverse connection may cause a load malfunction.

■ CN2 Connector Connection Example

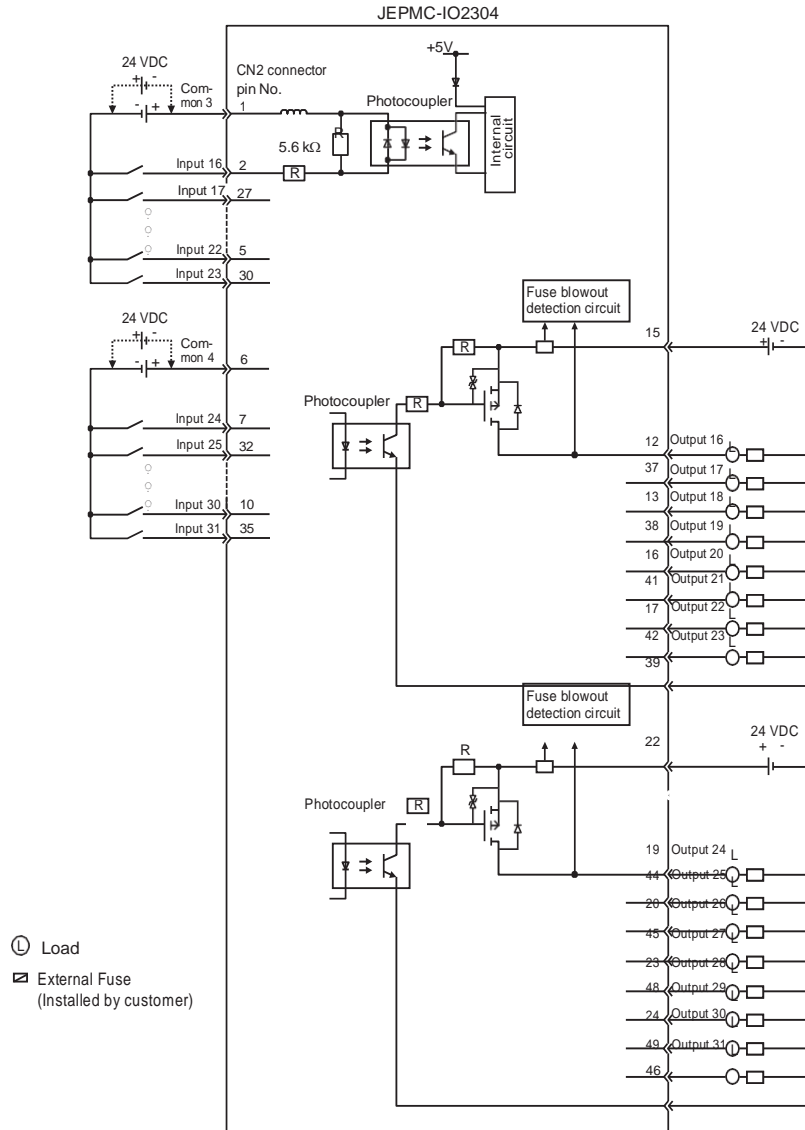

⚠ DANGER

Check the polarity of the external power supply when wiring. An adverse connection may cause a load malfunction.

22 Option Module - LIO-06 Module

◆ Module External Appearance

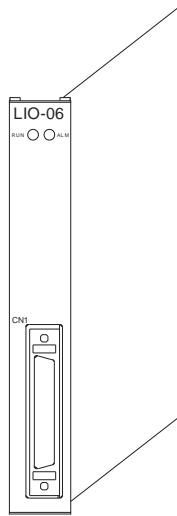

◆ Outline of Functions

The LIO-06 Module has digital I/O, analog I/O, and pulse encoder functionality, including a registration latch input. The LIO-06 Module is fully compatible with the MP940 I/O connector.

⚠ DANGER

When converting equipment from the prior generation MP940 controller, users should bear in mind that the analog inputs that had previously been wired to the V-REF and T-REF inputs on the SGDh must now be connected directly to the LIO-06 option module.

◆ LED Indicators and Switch Settings

Display name	Color	Status when Lit	Status when OFF
RUN	Green	Normal	Stopped. (No access by CPU)
ALM	Red	Fault	Normal operation

The ALM light indicates the following conditions

- Fuse fault
- ASIC error
- A-phase disconnect
- B-phase disconnect

◆ Option Board Specifications

Item		Specification	
Digital Input	Number of Inputs	8/Common	
	Input Method	Sink/Source	
	Isolation	Photocoupler Isolation	
	Input Voltage	DC24V±20% (DC19.2 to 28.8V)	
	Input Current	4.1mA (TYP)	
	ON Voltage/Current	At least 15V/At least 2mA	
	OFF Voltage/Current	5V Max/1mA Max	
	ON/OFF Time	ON= 0.5ms Max/OFF= 0.5ms Max	
	Interrupt	1 (used together with DI_00)	
Digital Output	Number of Outputs	8/Common	
	Output Method	Transistor Sink Output	
	Isolation	Photocoupler Isolation	
	External Power Supply Voltage	DC24V±20% (DC19.2 to 28.8V)	
	Output Current	100mA (Max)	
	ON Voltage	1V Max	
	Leak Current at OFF	0.1mA Max	
	ON/OFF Time	ON= 0.25ms Max/OFF= 1ms Max	
	Protection Classification	Unprotected output	
	Error Detection	Blown fuse detection	
Analog Input	Number of Channels	1	
	Isolation	Non-isolated	
	Analog Input Range	-10 to +10V	
	Maximum Rated Input	±15V	
	Input Impedance	Approx. 20kΩ	
	Resolution	16bit (-31276 to +31276)	
	Absolute Accuracy	100mV Max	
	Accuracy	25°C	±0.1% (±10mV)
		0 to 55°C	±0.3% (±30mV)
	Input Filter	Time Constant	0.2×10^{-3}
Delay Time		1ms(Max) (when -10 to 10V)	
Input Conversion Speed	50μs		
Analog Output	Number of Channels	1	
	Isolation	Non-isolated	
	Analog Output Range	-10 to +10V	
	Output Impedance	20Ω Max	
	Resolution	16bit (-31276 to +31276)	
	Accuracy	25°C	±0.1% (±10mV)
		0 to 55°C	±0.3% (±30mV)
	Maximum Permissible Load Current	±5mA	
	Output Delay Time	1.2ms (Time of change from -10+10V)	

DANGER

The time constant shows the characteristics according to the input filter equivalent to the time to reach $0.632 \times$ the input voltage.

Item		Specification		
Encoder Input	Encoder Input	Number of Channels	1	
		Input Method	5V Differential Max Frequency 4MHz	
		Isolation	Non-isolated	
		Counting System	A/B Phase Pulse/Direction UP/DOWN Counter	
	Latch Input	Number of Input Circuits	2 (C-Phase latch or digital input latch) The digital input latch is used in conjunction with DI-01 on pin 39.	
			C-Phase Latch	Digital Input Latch
		Input Method	Source Photocoupler I/F	Sink/Source Photocoupler I/F
		Isolation	Photocoupler Isolation	Photocoupler Isolation
		Input Voltage	24VDC±20% 12VDC±20% 5VDC±20% 24VDC/12VDC/5VDC are switched by connector wiring	DC24V±20%
		Input Current	DC24V: 11mA (TYP) DC12V: 12mA (TYP) DC5V: 13mA (TYP)	4.1mA (TYP)
		ON Voltage	DC24V: 17V Min DC12V: 9V Min DC5V: 3.9V Min	15V Min
		OFF Voltage	DC24V: 1.6V Max DC12V: 1.1V Max DC5V: 0.9V Max	5V Max
		Response Time	1µs Max	60µs Max
	Minimum ON Pulse Width	1µs	60µs	
COIN Output		1, digital output Used together with DO-07 (software switching)		
Current Consumption		5V, 1A Max		
Hot Swapping (Modules)		Not Possible		
Connector		CN1: Digital I/O, Analog I/O, Encoder Input		
Indicators		RUN (Green), ALM (Red)		

◆ Digital Input Circuit

The specifications of the LIO-06 module digital input circuit are shown below.

Item	Specification
Number of Inputs	8
Input Method	Sink/Source
Isolation	Photocoupler Isolation
Input Voltage	DC24V±20%
Input Current	4.1mA (TYP)
ON Voltage/Current	At least 15V/2.0mA
OFF Voltage/Current	5V Max/1.0mA Max
ON Time/OFF Time	ON=0.5ms Max/OFF=0.5ms Max
Number of Commons	1
Other Functions	DI_01 is used together with the position registration latch input, and when enabled, the position registration latch input latches with the pulse encoder when SI_01 is "ON".

◆ Digital Input Circuit Connection Example

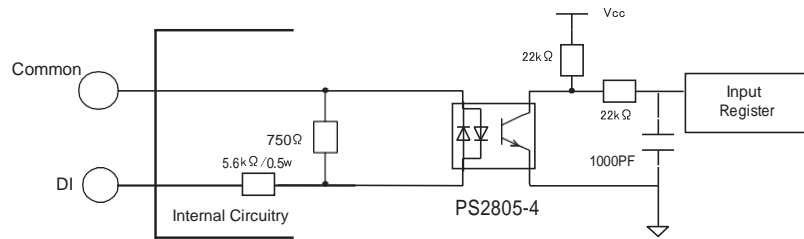

◆ Digital Output Circuit Connection Example

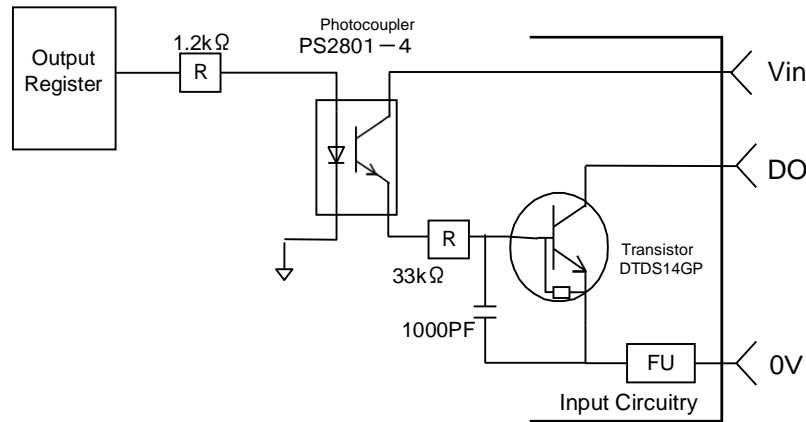

◆ Digital Output Circuit

The specifications of the LIO-06 digital output circuit are shown below.

Item	Specification
Number of Outputs	8
Output Method	Transistor Open Collector Sink Output
Isolation	Photocoupler Isolation
External Power Supply Voltage	DC24V±20%
Output Current	100mA Max
Leak Current at OFF	0.1mA Max
ON Time/OFF Time	ON=0.25ms Max/OFF=1ms Max
Number of Commons	1
Protection Circuit	The fuses are not for circuit protection. They are for fire protection at output shorts. A fuse should be attached outside each output when a protective circuit is necessary.
Fuse Rating	1A
Error Detection	Blown fuse detection

◆ Analog Input Circuit

The specifications of the LIO-06 analog input circuit are shown below.

Item		Specification
Analog Input Range		-10 to +10V
Number of Input Channels		1
Isolation		Non-isolated
Maximum Rated Input		±15V
Input Impedance		Approx. 20kΩ
Resolution		16-bit (-31276 to +31276)
Accuracy	25°C	±0.1%(±10mV)
	0 to 55°C	±0.3%(±30mV)
Input Filter	Time Constant	0.2×10^{-2}
	Delay Time	1 ms (Max) (When -10+10V)
Conversion Speed		50μs

⚠ DANGER

The time constant shows the characteristics according to the input filter equivalent to the time to reach $0.632 \times$ the input voltage.

◆ Analog Input Circuit Connection Example

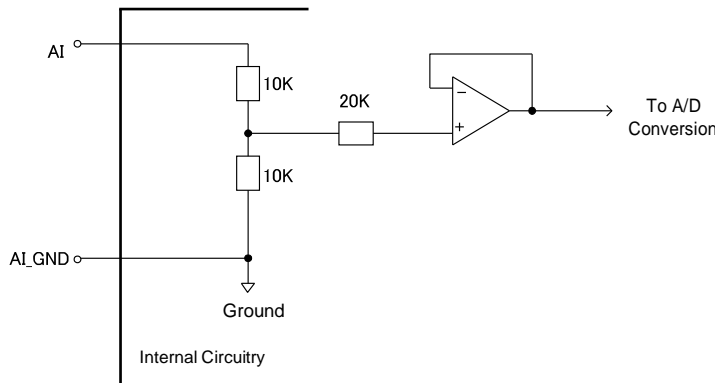

◆ Analog Input Characteristics Response Chart

The following shows an analog input response chart and input characteristics diagram for the LIO-06 module.

■ Input Characteristics Response Chart

Analog Input Value	Input Register Value
-10.5V	-32768
-10.0V	-31276
-5.0V	-15638
0.0V	0
+5.0V	15638
+10.0V	31276
+10.5V	32767

- Minimum linearity of +10.0V cannot be assured.

■ Voltage Input Characteristics Diagram

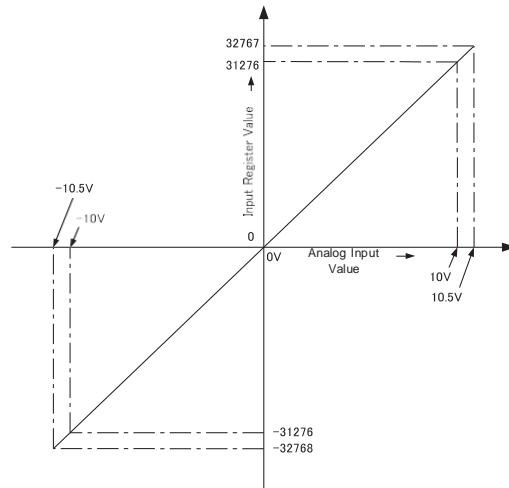

◆ Analog Output Circuit

The specifications of the LIO-06 analog output circuit are shown below.

Item		Specification
Output Range		-10 to +10V
Number of Output Channels		1
Isolation		Non-isolated
Maximum Permissible Load Current		±5mA
Resolution		16-Bit (-31276 to +31276)
Absolute	25°C	±0.1% (±10mV)
	0 to 55°C	±0.3% (±30mV)
Output Delay Time		1.2ms (Time of change from -10+10V)

◆ Analog Output Circuit Connection Example

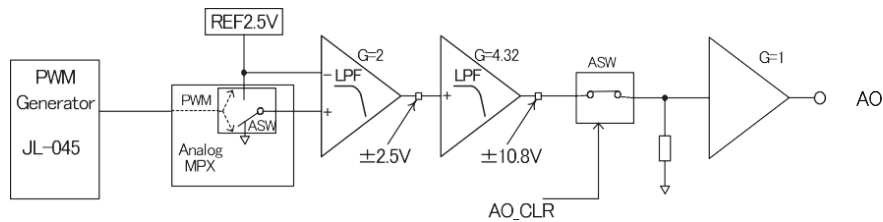

◆ Analog Output Characteristics Response Chart

The following shows an analog output response chart and output characteristics diagram for the LIO-06 module.

■ Output Characteristics Response Chart

Analog Output Value	Output Register Value
-10.5V	-32768
-10.0V	-31276
-5.0V	-15638
0.0V	0
+5.0V	15638
+10.0V	31276
+10.5V	32767

■ Voltage Output Characteristics Diagram

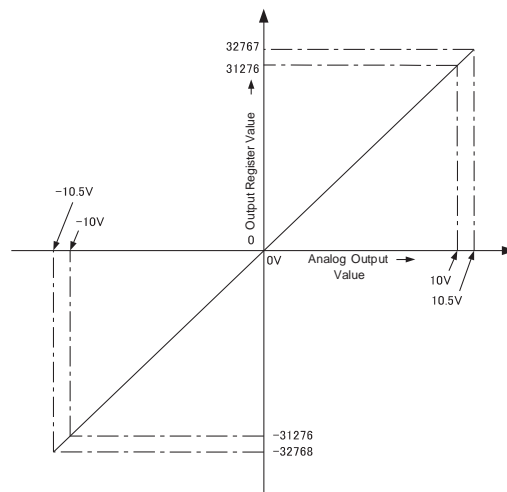

◆ Encoder Circuit

The specifications of the LIO-06 encoder circuit are shown below.

Item	Specification
Number of Encoders	1 channel (A/B/C-Phase Input)
Input Circuits	A/B-phase: 5V differential input, non-isolated, max frequency 4MHz C-Phase: 5V/12V/24V photocoupler input, max frequency 500kHz
Input Mode	A/B-phase, code, UP/DOWN counter, pulse, and direction
Latch Input	Position registration latch with C-Phase of DI_01 Response Time: Max 5μs during C-Phase input, During DI_01 Input: Max 60μs

◆ Encoder Input Circuit Connection Example

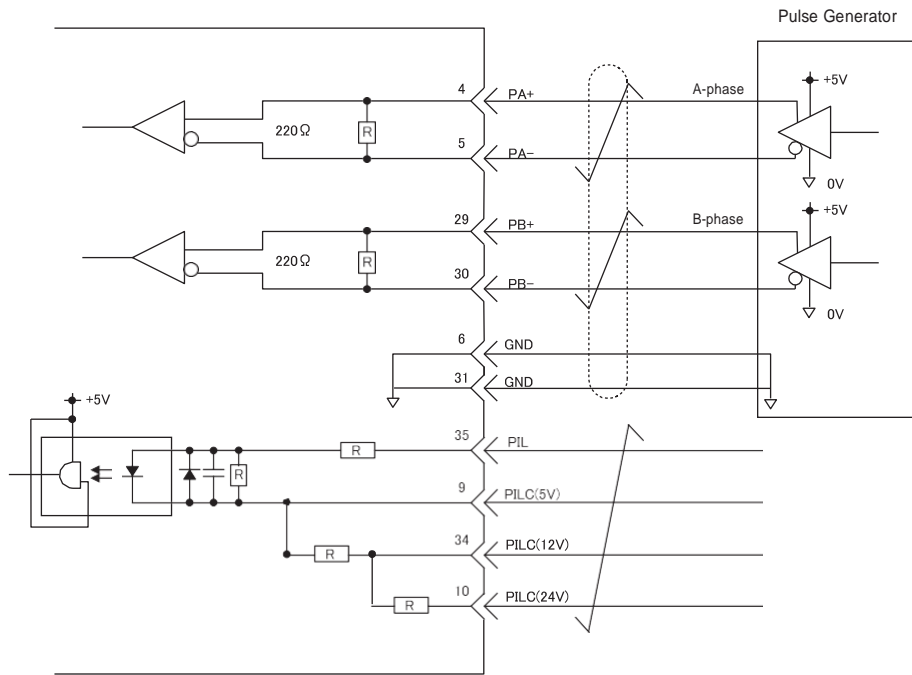

◆ LIO-06 Connectors and Pin Layouts

- Connectors

Item	Description	
Use Connector	10250-52A3PL (Sumitomo 3M)	LIO-06 Connector (RoHS-compatible)
Mating Connector	10150-3000VE (Sumitomo 3M)	Connector unit
	10150-3000PE (Sumitomo 3M)	Connector Unit (RoHS-compatible)
	10350-52A0-008 (Sumitomo 3M)	Shell screw lock type
	10350-52F0-008 (Sumitomo 3M)	One-touch lock type
Standard Cable	JEPMC-W2064-oo-E	Pigtail

◆ Standard Cable Model and External Appearance

Name	Model	Length	External Appearance (JEPMC-W2064-oo-E)
Cable for LIO-06 Module (Single loose wire)	JEPMC-W2064-A5-E	0.5 m	
	JEPMC-W2064-01-E	1 m	
	JEPMC-W2064-03-E	3 m	

◆ Standard Cable Wiring Table

The following shows the standard cable wiring for the JEPMC-W2064 cable.

Pin	Wire Color	Markings	Signal Name	Function
1	Orange	—	AO	Analog Output
2	Gray	—	AI	Analog Input
3	White	—	N.C.	

22 Option Module - LIO-06 Module

Pin	Wire Color	Markings	Signal Name	Function
4	Yellow	—	PA+	A_Pulse+
5	Pink	—	PA-	A_Pulse-
6	Orange	— —	GND	Pulse Input Ground
7	Gray	— —	N.C.	
8	White	— —	N.C.	
9	Yellow	— —	PILC5V	C-Phase Latch Input Common (5V)
10	Pink	— —	PILC24V	C-Phase Latch Input Common (24V)
11	Orange	— — —	N.C.	
12	Gray	— — —	N.C.	
13	White	— — —	DICOM	Digital Input Common
14	Yellow	— — —	DI_00	Digital Input 0
15	Pink	— — —	DI_02	Digital Input 2
16	Orange	— — — —	DI_04	Digital Input 4
17	Gray	— — — —	DI_06	Digital Input 6
18	White	— — — —	N.C.	
19	Yellow	— — — —	N.C.	
20	Pink	— — — —	DO_24V	Digital Output 24V Power Supply
21	Orange	— — — — Continuous	DO_00	Digital Output 0
22	Gray	— — — — Continuous	DO_02	Digital Output 2
23	White	— — — — Continuous	DO_04	Digital Output 4
24	Yellow	— — — — Continuous	DO_06	Digital Output 6
25	Pink	— — — — Continuous	DO_GND	Digital Output Common Ground
26	Orange	—	AO_GND	Analog Output Ground
27	Gray	—	AI_GND	Analog Input Ground
28	White	—	N.C.	
29	Yellow	—	PB+	B_Pulse+
30	Pink	—	PB-	B_Pulse-
31	Orange	— —	GND	Pulse input ground
32	Gray	— —	N.C.	
33	White	— —	N.C.	
34	Yellow	— —	PILC12V	C-Phase latch input common (12V)
35	Pink	— —	PIL	C-Phase latch input
36	Orange	— — —	N.C.	
37	Gray	— — —	N.C.	
38	White	— — —	DICOM	Digital Input Common
39	Yellow	— — —	DI_01	Digital Input 1
40	Pink	— — —	DI_03	Digital Input 3
41	Orange	— — — Continuous	DI_05	Digital Input 5
42	Gray	— — — Continuous	DI_07	Digital Input 7
43	White	— — — Continuous	N.C.	
44	Yellow	— — — Continuous	N.C.	
45	Pink	— — — Continuous	DO_24V	Digital output 24V Power Supply
46	Orange	— — — —	DO_01	Digital Output 1
47	Gray	— — — —	DO_03	Digital Output 3
48	White	— — — —	DO_05	Digital Output 5
49	Yellow	— — — —	DO_07	Digital Output 7
50	Pink	— — — —	DO_GND	Digital output common ground
Shell				Shield Wire

◆ LIO-06 Module Connector Connection Example

An example of LIO-06 module connector connection is shown below.

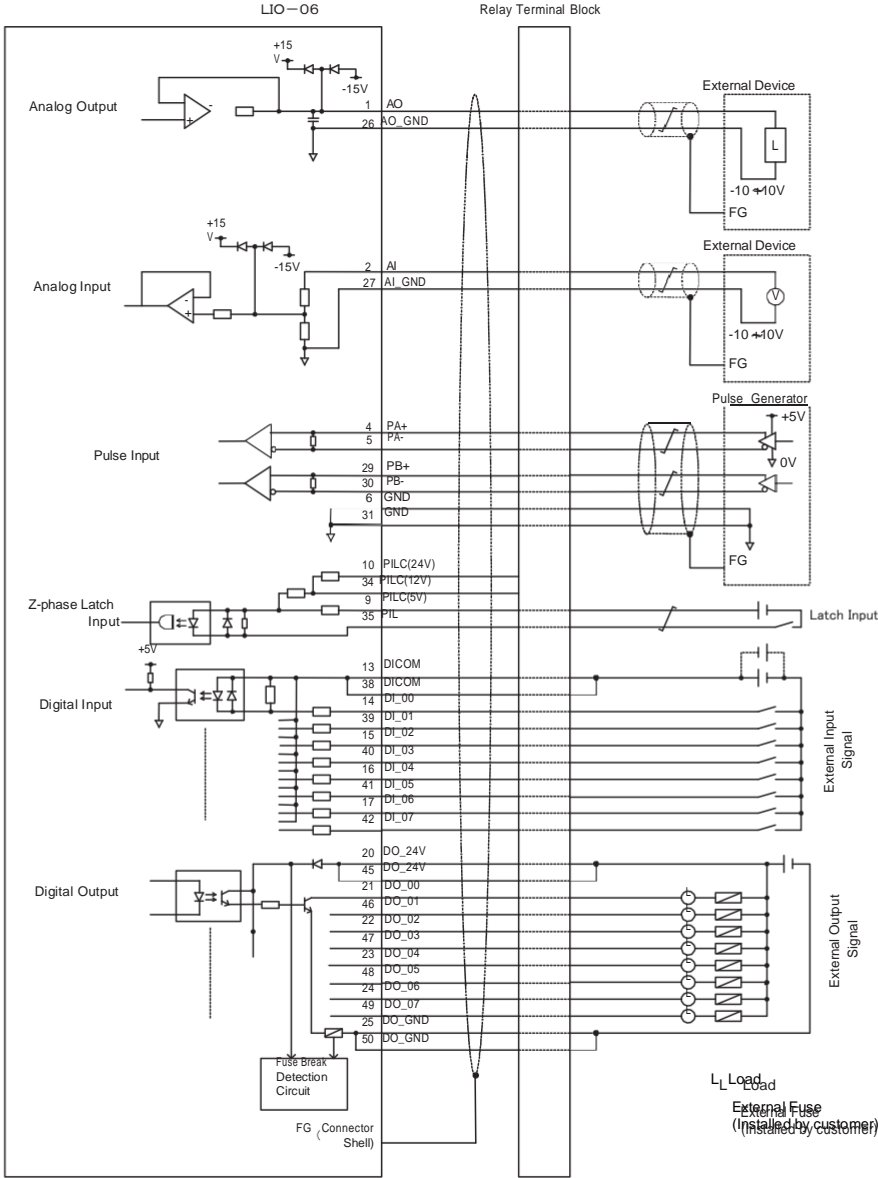

⚠ DANGER

The cable shield between the external equipment and the junction terminal block should be installed on the external device side.

23 Option Module – 218IF-Y1

◆ Outline of Functions

The 218IF-01 Module has an RS-232C serial interface and an Ethernet interface mounted in it. Personal computers, HMI devices, and controllers manufactured by other companies can be connected to the 218IF-01 Module via the serial or Ethernet connectors.

◆ Hardware

Item	Specifications
Name	218IF-Y1
Model	JAPMC-CM2301-E
Communication Ports	RS-232C 1 port (PORT)
	Ethernet 1 port (10Base-T)
Indicators	Module status LED indicators RUN (green), ERR (red), STRX (green), COL (red), TX (green), RX (green)
Switches	INIT
	TEST
Dimensions (mm)	125 × 95 (H × D)
Mass	85 g

◆ Functional Specification

Item	218IF-Y1	
Interface	RS-232 D-sub 9	Ethernet RJ-45
Transmission distance	15 m	100 M/segment (500m in total extension)
Transmission speed	Configurable between 9600 and 57600 bps.	10 Mbps
Access method	Start-stop synchronization	IEEE802.3
Frame format	-	Ethernet Ver.2 (DIX specification)
Connection type	-	TCP/UDP/IP/ARP
Connection status	1:1	1:N
Transmission format	Data bit length: 5, 6, 7, or 8 Bit Stop bit: 1 or 2 Bit Parity bit: none, odd, or even	-

◆ Indicators

Reference	Light Name	Display Color	State When Lit	Remarks
D1	RUN	Green	normally operation	Software control (Out port)
	ERR	Red	Error condition	Software control (Out port)
D2	STRX	Green	Sending and receiving RS-232 data.	Hardware control (LAN controller)
	COL	Green	Ethernet collision	Hardware control (LAN controller)
D3	TX	Green	Transmitting Ethernet data.	Hardware control (LAN controller)
	RX	Green	Receiving Ethernet data.	Hardware control (LAN controller)

◆ Switch Settings

Reference	Switch Name	State	Operational mode	Default Setting	Remarks
S1_4	-	ON	Reserved	OFF	reserved
		OFF	Usually		reserved
S1_3	-	ON	Reserved	OFF	reserved
		OFF			
S1_2	INIT	ON	Forced IP address	OFF	reserved
		OFF	Use IP settings stored on controller.		
S1_1	TEST	ON	Reserved	OFF	reserved
		OFF			

All switches on the 218IF-Y1 card must remain off.

◆ Connector Table

■ Port Connector (CN1)

Item	Type	Names of Parts and Maker						
Use connector	D-sub 9pin Socket	17LE-13090-27D2BC)-FA (DDK)						
Engagement connector	D-sub 9pin Plug	17JE-23090-02(D8B) Another (DDK)						
Pin layout	Number	Signal name	I/O	Remarks	Number	Signal name	I/O	Remarks
	1	FG	O	Protective ground	6	DR	I	Transmission control
	2	SD	O	Transmission data	7	GND	P	Signal ground
	3	RD	I	Received data	8	-	-	-
	4	RS	O	Transmission request	9	ER	O	Data terminal ready
	5	CS	I	It is possible to transmit				
RS-232C cable for MP2xxx JEPMC-W5311-**								

■ Ethernet Connector (CN2)

Item	Type	Names of Parts and Maker						
Use connector	RJ-45 (cat.5)	5555153-1 (Tyco AMP)						
Engagement connector	RJ-45 (cat.5) Plug							
Pin layout	Number	Signal name	I/O	Remarks	Number	Signal name	I/O	Remarks
	1	TXD+	I/O	Transmission data + side	5	-	-	-
	2	TXD-	O	Transmission data?Side	6	RXD-	I	Received data side
	3	RXD+	O	Receive data + side	7	-	-	-
	4	-	-	-	8	-	-	-

24 Terminal Block 60372499 and Cable CBL-MP2A-XXA

Terminal Block and Cable for LIO-01/LIO-02

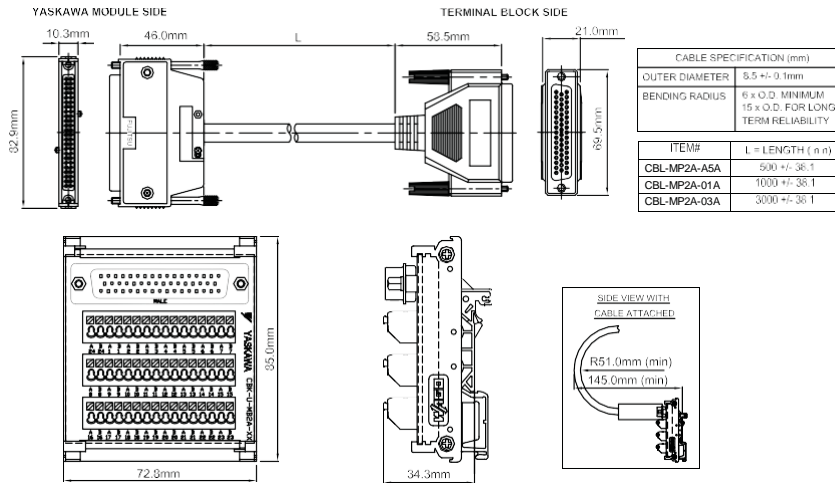

Functionality Chart for Terminal Block 60372499 and Cable CBL-MP2A-XXA

Pin No.	LIO-01 (JAPMC-IO2300) LIO-02 (JAPMC-IO2301)		Pin No.	LIO-01 (JAPMC-IO2300) LIO-02 (JAPMC-IO2301)	
	Signal	Function		Signal	Function
A1	PA	Phase-A pulse (+)	A13	DO_03	Output 3
B1	PAL	Phase-A pulse (-)	B13	DO_02	Output 2
A2	PB	Phase-B pulse (+)	A14	DO_01	Output 1 (Shared with high speed output (COIN) function)
B2	PBL	Phase-B pulse (-)	B14	DO_00	Output 0
A3	PC	Phase-C latch pulse (+)	A15	DI_15	Input 15
B3	PCL5	Phase-C latch pulse (-) for 5vdc input	B15	DI_14	Input 14
A4	GND	Encoder input ground	A16	DI_13	Input 13
B4	PCL12	Phase-C latch pulse (-) for 12vdc input	B16	DI_12	Input 12
A5	DO_COM	Output 0V common	A17	DI_11	Input 11
B5	DO_COM	Output 0V common	B17	DI_10	Input 10
A6	DO_24V	Digital output +24V supply	A18	DI_09	Input 9
B6	DO_24V	Digital output +24V supply	B18	DI_08	Input 8
A7	DO_15	Output 15	A19	DI_07	Input 7
B7	DO_14	Output 14	B19	DI_06	Input 6
A8	DO_13	Output 13	A20	DI_05	Input 5
B8	DO_12	Output 12	B20	DI_04	Input 4
A9	DO_11	Output 11	A21	DI_03	Input 3
B9	DO_10	Output 10	B21	DI_02	Input 2
A10	DO_09	Output 9	A22	DI_01	Input 1 (Shared with pulse latch input)
B10	DO_08	Output 8	B22	DI_00	Input 0
A11	DO_07	Output 7	A23	DI_COM0	Input common 0
B11	DO_06	Output 6	B23	DI_COM1	Input common 1
A12	DO_05	Output 5	A24	FG	Frame ground
B12	DO_04	Output 4	B24	FG	Frame ground

25 Terminal Block 60372471 and Cable CBL-MP2B-XXA

Terminal Block and Cable for LIO-04/LIO-05/LIO-06

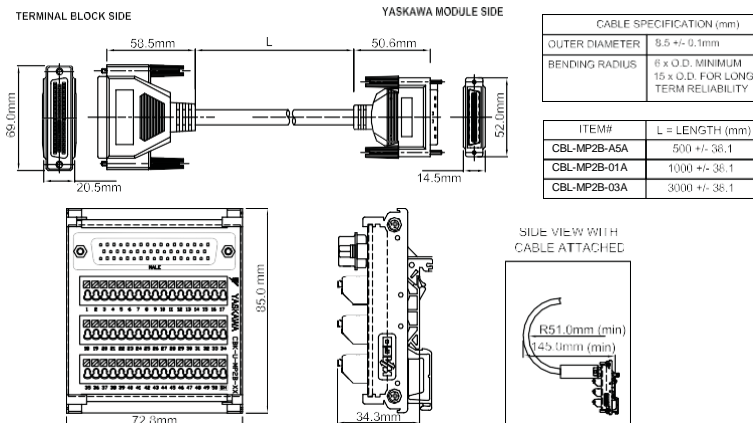

Functionality Chart for Terminal Block 60372471 and Cable CBL-MP2B-XXA

Pin No.	LIO-04 (JAPMC-IO2303) / LIO-05 (JAPMC-IO2304)				LIO-06 (JAPMC-IO2305-E)	
	CN1 Signal	CN1 Function	CN2 Signal	CN2 Function	Signal	Function
1	DICOM_1	Digital input common 1	DICOM_3	Digital input common 3	AO	Analog output
2	DI_00	Digital input 0	DI_16	Digital input 16	AI	Analog input
3	DI_02	Digital input 2	DI_18	Digital input 18	-	-
4	DI_04	Digital input 4	DI_20	Digital input 20	PA+	Phase A pulse (+)
5	DI_06	Digital input 6	DI_22	Digital input 22	PA-	Phase A pulse (-)
6	DICOM_2	Digital input common 2	DICOM_4	Digital input common 4	GND	Encoder input ground
7	DI_08	Digital input 8	DI_24	Digital input 24	-	-
8	DI_10	Digital input 10	DI_26	Digital input 26	-	-
9	DI_12	Digital input 12	DI_28	Digital input 28	PILC5V	Phase-C latch pulse (-) for 5VDC input
10	DI_14	Digital input 14	DI_30	Digital input 30	PILC24V	Phase-C latch pulse (-) for 24VDC input
11	-	-	-	-	-	-
12	DO_00	Digital output 0	DO_16	Digital output 16	-	-
13	DO_02	Digital output 2	DO_18	Digital output 18	DICOM	Digital input common
14	-	-	-	-	DI_00	Digital input 0
15	+24V_1	Digital output supply 1	+24V_3	Digital output supply 3	DI_02	Digital input 2
16	DO_04	Digital output 4	DO_20	Digital output 20	DI_04	Digital input 4
17	DO_06	Digital output 6	DO_22	Digital output 22	DI_06	Digital input 6
18	-	-	-	-	-	-
19	DO_08	Digital output 8	DO_24	Digital output 24	-	-
20	DO_10	Digital output 10	DO_26	Digital output 26	DO_24V	Digital output 24V supply
21	-	-	-	-	DO_00	Digital output 0
22	+24V_2	Digital output supply 2	+24V_4	Digital output supply 4	DO_02	Digital output 2
23	DO_12	Digital output 12	DO_28	Digital output 28	DO_04	Digital output 4
24	DO_14	Digital output 14	DO_30	Digital output 30	DO_06	Digital output 6
25	-	-	-	-	DO_GND	Digital output 0V common
26	-	-	-	-	AO_GND	Analog output ground
27	DI_01	Digital input 1	DI_17	Digital input 17	AI_GND	Analog input ground
28	DI_03	Digital input 3	DI_19	Digital input 19	-	-
29	DI_05	Digital input 5	DI_21	Digital input 21	PB+	Phase-B pulse (+)
30	DI_07	Digital input 7	DI_23	Digital input 23	PB-	Phase-B pulse (-)
31	-	-	-	-	GND	Encoder input ground
32	DI_09	Digital input 9	DI_25	Digital input 25	-	-
33	DI_11	Digital input 11	DI_27	Digital input 27	-	-
34	DI_13	Digital input 13	DI_29	Digital input 29	PILC12V	Phase-C latch pulse (-) for 12VDC input
35	DI_15	Digital input 15	DI_31	Digital input 31	PIL	Phase-C latch pulse (+)
36	-	-	-	-	-	-
37	DO_01	Digital output 1	DO_17	Digital output 17	-	-
38	DO_03	Digital output 3	DO_19	Digital output 19	DICOM	Digital input common
39	0V_1	Digital output 0VDC 1	0V_3	Digital output 0VDC 3	DI_01	Digital input 1 (shared with pulse latch input)
40	-	-	-	-	DI_03	Digital input 3
41	DO_05	Digital output 5	DO_21	Digital output 21	DI_05	Digital input 5
42	DO_07	Digital output 7	DO_23	Digital output 23	DI_07	Digital input 7
43	-	-	-	-	-	-
44	DO_09	Digital output 9	DO_25	Digital output 25	-	-
45	DO_11	Digital output 11	DO_27	Digital output 27	DO_24V	Digital output 24V supply
46	0V_2	Digital output 0VDC 2	0V_4	Digital output 0VDC 4	DO_01	Digital output 1
47	-	-	-	-	DO_03	Digital output 3
48	DO_13	Digital output 13	DO_29	Digital output 29	DO_05	Digital output 5
49	DO_15	Digital output 15	DO_31	Digital output 31	DO_07	Digital output 7 (shared with position agreement 'COIN' signal)
50	-	-	-	-	DO_GND	Digital output 0V common

26 Terminal Block 60372501 and Cable CBL-MP2C-XXC

Terminal Block and Cable for IO3300iec
(64-Point I/O Module)

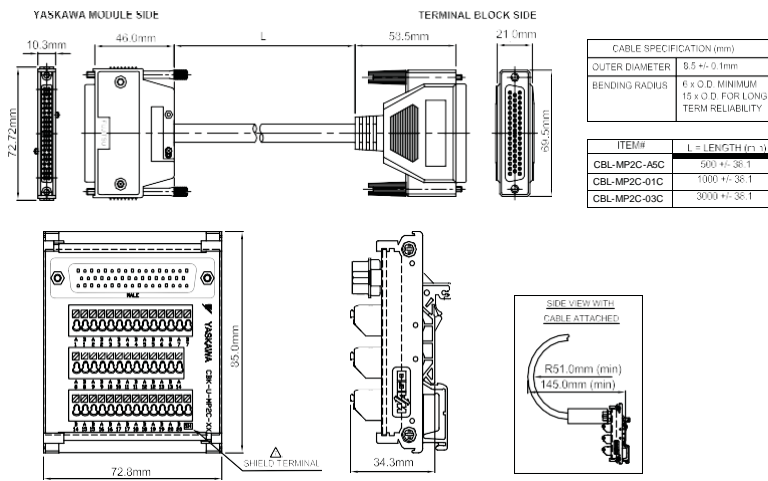

Functionality Chart for Terminal Block 60372501 and Cable CBL-MP2C-XXC

Pin No.	JEPMC-IO2310 and JEPMC-IO2330							
	IN1 signal	IN1 function	IN2 signal	IN2 function	OUT1 signal	OUT1 function	OUT2 signal	OUT2 function
A1	-	-	-	-	024V_6	Common ground 6	024V_8	Common ground 8
B1	-	-	-	-	024V_6	Common ground 6	024V_8	Common ground 8
A2	+24V_2	24V power supply 2	+24V_4	24V power supply 4	+24V_6	24V power supply 6	+24V_8	24V power supply 8
B2	+24V_2	24V power supply 2	+24V_4	24V power supply 4	+24V_6	24V power supply 6	+24V_8	24V power supply 8
A3	IN32	Input 32	IN64	Input 64	OUT32	Output 32	OUT64	Output 64
B3	IN31	Input 31	IN63	Input 63	OUT31	Output 31	OUT63	Output 63
A4	IN30	Input 30	IN62	Input 62	OUT30	Output 30	OUT62	Output 62
B4	IN29	Input 29	IN61	Input 61	OUT29	Output 29	OUT61	Output 61
A5	IN28	Input 28	IN60	Input 60	OUT28	Output 28	OUT60	Output 60
B5	IN27	Input 27	IN59	Input 59	OUT27	Output 27	OUT59	Output 59
A6	IN26	Input 26	IN58	Input 58	OUT26	Output 26	OUT58	Output 58
B6	IN25	Input 25	IN57	Input 57	OUT25	Output 25	OUT57	Output 57
A7	IN24	Input 24	IN56	Input 56	OUT24	Output 24	OUT56	Output 56
B7	IN23	Input 23	IN55	Input 55	OUT23	Output 23	OUT55	Output 55
A8	IN22	Input 22	IN54	Input 54	OUT22	Output 22	OUT54	Output 54
B8	IN21	Input 21	IN53	Input 53	OUT21	Output 21	OUT53	Output 53
A9	IN20	Input 20	IN52	Input 52	OUT20	Output 20	OUT52	Output 52
B9	IN19	Input 19	IN51	Input 51	OUT19	Output 19	OUT51	Output 51
A10	IN18	Input 18	IN50	Input 50	OUT18	Output 18	OUT50	Output 50
B10	IN17	Input 17	IN49	Input 49	OUT17	Output 17	OUT49	Output 49
A11	IN16	Input 16	IN48	Input 48	OUT16	Output 16	OUT48	Output 48
B11	IN15	Input 15	IN47	Input 47	OUT15	Output 15	OUT47	Output 47
A12	IN14	Input 14	IN46	Input 46	OUT14	Output 14	OUT46	Output 46
B12	IN13	Input 13	IN45	Input 45	OUT13	Output 13	OUT45	Output 45
A13	IN12	Input 12	IN44	Input 44	OUT12	Output 12	OUT44	Output 44
B13	IN11	Input 11	IN43	Input 43	OUT11	Output 11	OUT43	Output 43
A14	IN10	Input 10	IN42	Input 42	OUT10	Output 10	OUT42	Output 42
B14	IN09	Input 9	IN41	Input 41	OUT09	Output 9	OUT41	Output 41
A15	IN08	Input 8	IN40	Input 40	OUT08	Output 8	OUT40	Output 40
B15	IN07	Input 7	IN39	Input 39	OUT07	Output 7	OUT39	Output 39
A16	IN06	Input 6	IN38	Input 38	OUT06	Output 6	OUT38	Output 38
B16	IN05	Input 5	IN37	Input 37	OUT05	Output 5	OUT37	Output 37
A17	IN04	Input 4	IN36	Input 36	OUT04	Output 4	OUT36	Output 36
B17	IN03	Input 3	IN35	Input 35	OUT03	Output 3	OUT35	Output 35
A18	IN02	Input 2	IN34	Input 34	OUT02	Output 2	OUT34	Output 34
B18	IN01	Input 1	IN33	Input 33	OUT01	Output 1	OUT33	Output 33
A19	-	-	-	-	024V_5	Common ground 5	024V_7	Common ground 7
B19	-	-	-	-	024V_5	Common ground 5	024V_7	Common ground 7
A20	+24V_1	24V power supply 1	+24V_3	24V power supply 3	+24V_5	24V power supply 5	+24V_7	24V power supply 7
B20	+24V_1	24V power supply 1	+24V_3	24V power supply 3	+24V_5	24V power supply 5	+24V_7	24V power supply 7

27 Cable Shielding, Segregation and Noise Immunity

Proper

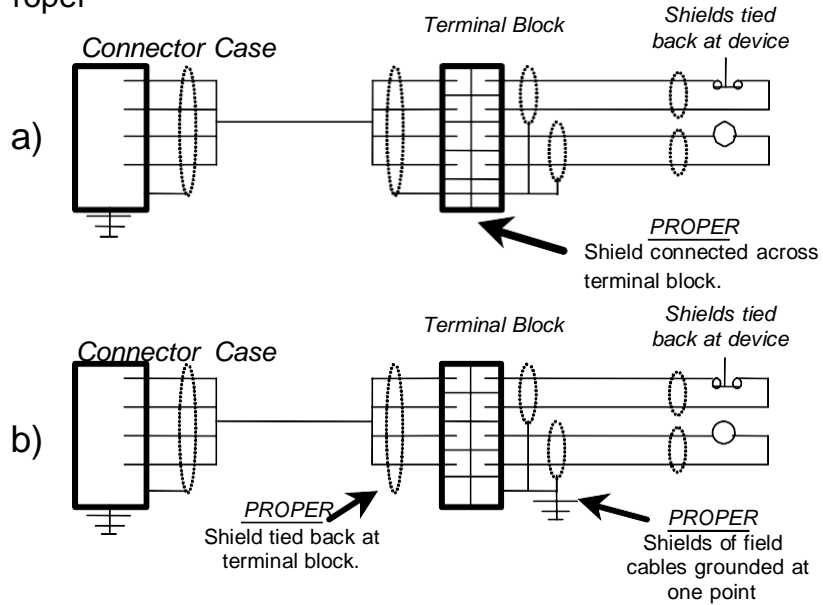

Wrong

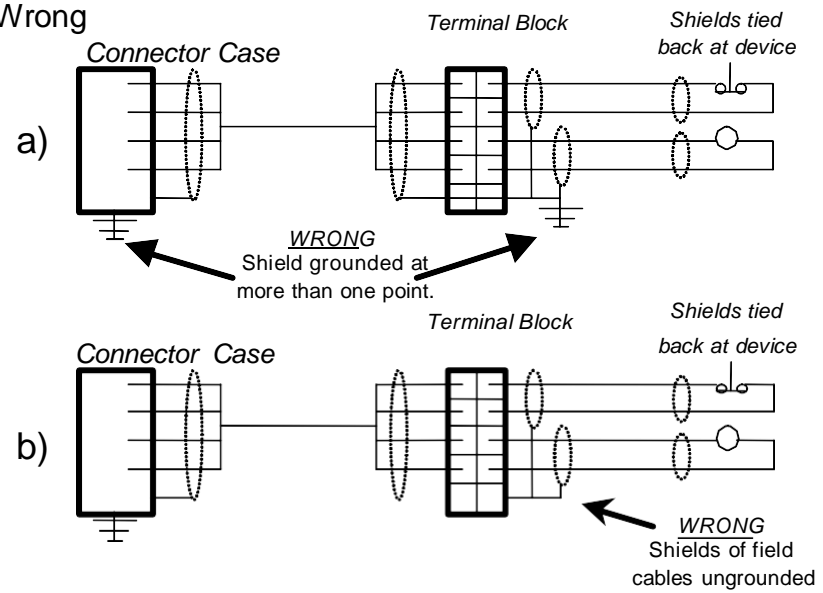

27 Cable Shielding, Segregation and Noise Immunity

Revision History

The revision dates and the numbers of the revised manuals appear on the bottom of the back cover.

Date of Publication	Revision Number	Section	Revised Content
May 2014	-	-	First Edition.
November 2017	A-1-1	-	Addition of High Performance Models (1.2GHz) and Robot Controller models.
December 2022	A-1-7		Addition of AC and DC Power Connector diagrams

YASKAWA MP3300iec

Machine Controller

Hardware Manual

← 表紙のタイトルを80%縮小して入れる。

IRUMA BUSINESS CENTER (SOLUTION CENTER)

480, Kamifujisawa, Iruma, Saitama 358-8555, Japan
Phone 81-4-2962-5151 Fax 81-4-2962-6138

YASKAWA AMERICA, INC.

2121 Norman Drive South, Waukegan, IL 60085, U.S.A.
Phone (800) YASKAWA (800-927-5292) or 1-847-887-7000 Fax 1-847-887-7310

YASKAWA ELÉTRICO DO BRASIL LTDA.

Avenida Fagundes Filho, 620 São Paulo-SP CEP 04304-000, Brazil
Phone 55-11-3585-1100 Fax 55-11-5581-8795

YASKAWA EUROPE GmbH

Hauptstraße 185, Eschborn 65760, Germany
Phone 49-6196-569-300 Fax 49-6196-569-398

YASKAWA ELECTRIC UK LTD.

1 Hunt Hill Orchardton Woods Cumbernauld, G68 9LF, United Kingdom
Phone 44-1236-735000 Fax 44-1236-458182

YASKAWA ELECTRIC KOREA CORPORATION

9F, Kyobo Securities Bldg. 26-4, Yeouido-dong, Yeongdeungpo-gu, Seoul, 150-737, Korea
Phone 82-2-784-7844 Fax 82-2-784-8495

YASKAWA ELECTRIC (SINGAPORE) PTE. LTD.

151 Lorong Chuan, #04-01, New Tech Park 556741, Singapore
Phone 65-6282-3003 Fax 65-6289-3003

YASKAWA ELECTRIC (SHANGHAI) CO., LTD.

12F, Carlton Bld., No.21 HuangHe Road, HuangPu District, Shanghai 200003, China
Phone 86-21-5385-2200 Fax 86-21-5385-3299

YASKAWA ELECTRIC (SHANGHAI) CO., LTD. BEIJING OFFICE

Room 1011, Tower W3 Oriental Plaza, No.1 East Chang An Ave.,
Dong Cheng District, Beijing 100738, China
Phone 86-10-8518-4086 Fax 86-10-8518-4082

YASKAWA ELECTRIC TAIWAN CORPORATION

9F, 16, Nanking E. Rd., Sec. 3, Taipei 104, Taiwan
Phone 886-2-2502-5003 Fax 886-2-2505-1280

YASKAWA

YASKAWA AMERICA, INC.

In the event that the end user of this product is to be the military and said product is to be employed in any weapons systems or the manufacture thereof, the export will fall under the relevant regulations as stipulated in the Foreign Exchange and Foreign Trade Regulations. Therefore, be sure to follow all procedures and submit all relevant documentation according to any and all rules, regulations and laws that may apply.

Specifications are subject to change without notice for ongoing product modifications and improvements.

© 2015-2017 YASKAWA AMERICA, INC.. All rights reserved.



MANUAL NO. YAI-SIA-IEC-7

Published in U.S.A. December, 2022

◇-1-7