



Nominal data

Type	3900	
Phase		1~
Nominal voltage	VAC	115
Frequency	Hz	60
Speed (rpm)	min ⁻¹	3150
Power consumption	W	9.0
Min. ambient temperature	°C	-20
Max. ambient temperature	°C	80
Air flow	m ³ /h	70
Sound power level	B	5.1
Sound pressure level	dB(A)	40

ml = Max. load · me = Max. efficiency · fa = Free air · cs = Customer specification · ce = Customer equipment
Subject to change

Technical description

Weight	0.280 kg
Dimensions	92 x 92 x 25 mm
Impeller material	Mineral-reinforced PA plastic
Housing material	Die-cast aluminum
Part no.	9282708116
Airflow direction	Exhaust over struts
Direction of rotation	Counterclockwise, viewed toward rotor
Storage	Sintec sleeve bearing
Service life L10 at 40 °C	60000 h
Service life L10 at maximum temperature	22500 h
Cable	2 flat plugs 2.8 x 0.5 mm. Housing with grounding lug for M4 screw.
Motor protection	Protected from overload by impedance protection
Approval	VDE, CSA, UL, CE

Product drawing

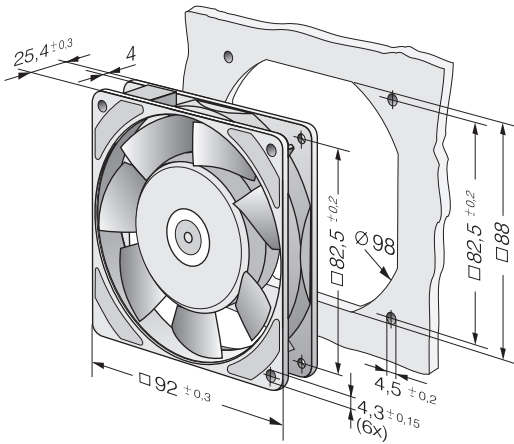

Curves: Air performance

