



Nominal data

Type	RG 125-19/12 NM	
Nominal voltage	VDC	12
Nominal voltage range	VDC	7 .. 15
Speed (rpm)	min ⁻¹	1750
Power consumption	W	2.0
Min. ambient temperature	°C	-30
Max. ambient temperature	°C	75
Air flow	m ³ /h	60
Sound power level	B	4.8

ml = Max. load · me = Max. efficiency · fa = Free air · cs = Customer specification · ce = Customer equipment
Subject to change

Technical description

General description	Backward-curved impeller
Weight	0.730 kg
Dimensions	180 x 180 x 40 mm
Impeller material	Glass-fiber reinforced plastic.
Housing material	Scroll housing made of glass-fiber reinforced plastic, housing base made of sheet steel.
Airflow direction	Axial intake, radial discharge from outlet.
Storage	Ball bearing
Service life L10 at 40 °C	70000 h
Service life L10 at maximum temperature	30000 h
Cable	With leads AWG 22, TR 64
Motor protection	Protection against reverse polarity and blocked rotor.
Locked-rotor protection	Locked-rotor and overload protection
Approval	VDE, CSA, UL, CE

Product drawing

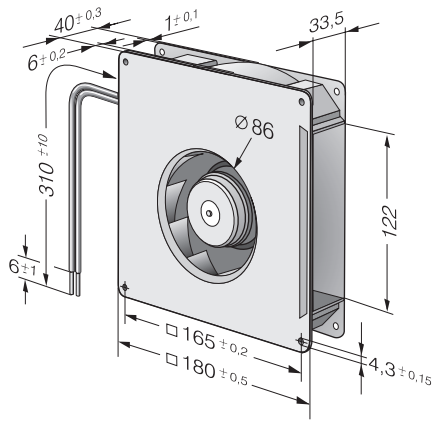

Curves: Air performance

