

RG 160-28/12 N

DC centrifugal compact fan

single-intake



Nominal data

Type	RG 160-28/12 N	
Nominal voltage	VDC	12
Nominal voltage range	VDC	7.5 .. 14
Speed (rpm)	min ⁻¹	2850
Power consumption	W	21.0
Min. ambient temperature	°C	-20
Max. ambient temperature	°C	70
Air flow	m ³ /h	209
Sound power level	B	6.6

ml = Max. load · me = Max. efficiency · fa = Free air · cs = Customer specification · ce = Customer equipment
Subject to change



Technical description

General description	Backward-curved impeller
Weight	1.400 kg
Dimensions	220 x 220 x 56 mm
Impeller material	Glass-fiber reinforced plastic
Housing material	Scroll housing made of glass-fiber reinforced plastic, housing base made of sheet steel.
Airflow direction	Axial intake, radial discharge from outlet.
Storage	Ball bearing
Service life L10 at 40 °C	70000 h
Service life L10 at maximum temperature	35000 h
Cable	With leads AWG 22, TR 64
Motor protection	Protection against reverse polarity and blocked rotor.
Locked-rotor protection	With electronic overload protection
Approval	VDE, CSA, UL, CE
Option	Speed signal

Product drawing

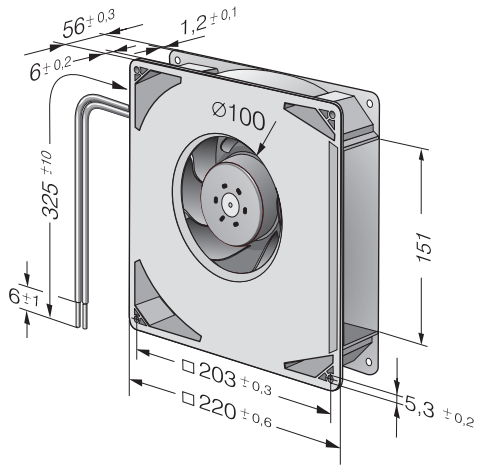

Curves: Air performance

