

Nominal data

Type	RL 48-19/12	
Nominal voltage	VDC	12
Nominal voltage range	VDC	8 .. 13.5
Speed (rpm)	min ⁻¹	4400
Power consumption	W	4.6
Min. ambient temperature	°C	-20
Max. ambient temperature	°C	70
Air flow	m ³ /h	28
Sound power level	B	5.7

ml = Max. load · me = Max. efficiency · fa = Free air · cs = Customer specification · ce = Customer equipment
Subject to change

DC centrifugal compact fan

single-intake

Technical description

General description	Forward-curved impeller
Weight	0.075 kg
Dimensions	76 x 76 x 27 mm
Impeller material	Glass-fiber reinforced plastic
Housing material	Scroll housing made of glass-fiber reinforced plastic.
Airflow direction	Axial intake, radial discharge from outlet.
Storage	Ball bearing
Service life L10 at 40 °C	60000 h
Service life L10 at maximum temperature	30000 h
Cable	With leads AWG 26, TR 64
Motor protection	Protection against reverse polarity and blocked rotor.
Locked-rotor protection	Electronic locked-rotor protection
Approval	VDE, CSA, UL, CE
Option	Speed signal

Product drawing

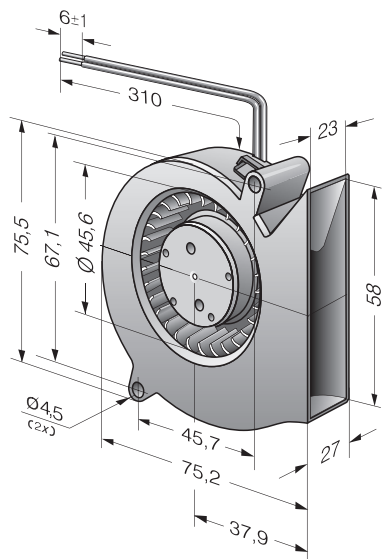

Curves

